

Customer Information Sheet

DRAWING No.: M80-4T2XXXXFJ

IF IN DOUBT - ASK

©

NOT TO SCALE

THIRD ANGLE PROJECTION

ALL DIMENSIONS IN mm

SPECIFICATIONS:

MATERIAL:
 MOULDING = GLASS-FILLED PPS, UL94V-0, BLACK
 CONTACT CLIP = BERYLLIUM COPPER
 CONTACT SHELL = BRASS
 GUIDE & NUT = STAINLESS STEEL

FINISH:
 01 = 0.3µ GOLD CLIP, 3.5-5.0µ TIN/LEAD SHELL
 05 = 0.3µ GOLD CLIP, 0.25-0.3µ GOLD SHELL
 42 = 0.3µ GOLD CLIP,
 3.5-5.0µ 100% TIN OVER NICKEL SHELL

ELECTRICAL:
 CURRENT RATING AT 25°C = 3.0A MAX
 CURRENT RATING AT 85°C = 2.2A MAX
 WORKING VOLTAGE = 800V AC/DC
 VOLTAGE PROOF = 1200V AC/DC
 CONTACT RESISTANCE = 25 mΩ MAX
 INSULATION RESISTANCE = 100 MΩ MIN

MECHANICAL:
 DURABILITY = 500 OPERATIONS
 INSERTION FORCE (∅0.5mm GAUGE) = 2.8N MAX
 WITHDRAWAL FORCE (∅0.5mm GAUGE) = 0.2N MIN

ENVIRONMENTAL:
 TEMPERATURE RANGE = -55°C TO +125°C

PACKING:
 TUBE
 FOR COMPLETE SPECIFICATION, SEE
 COMPONENT SPEC C005XX (LATEST ISSUE)

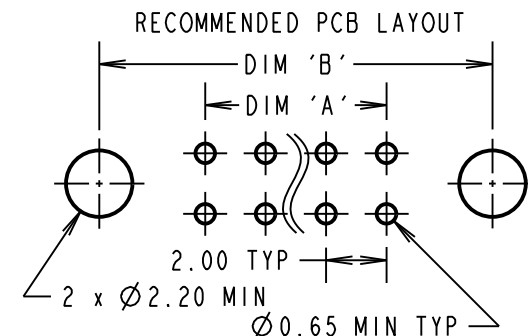
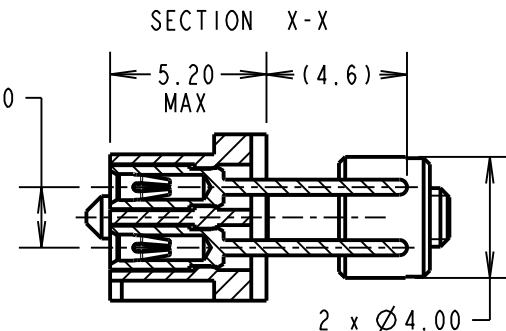
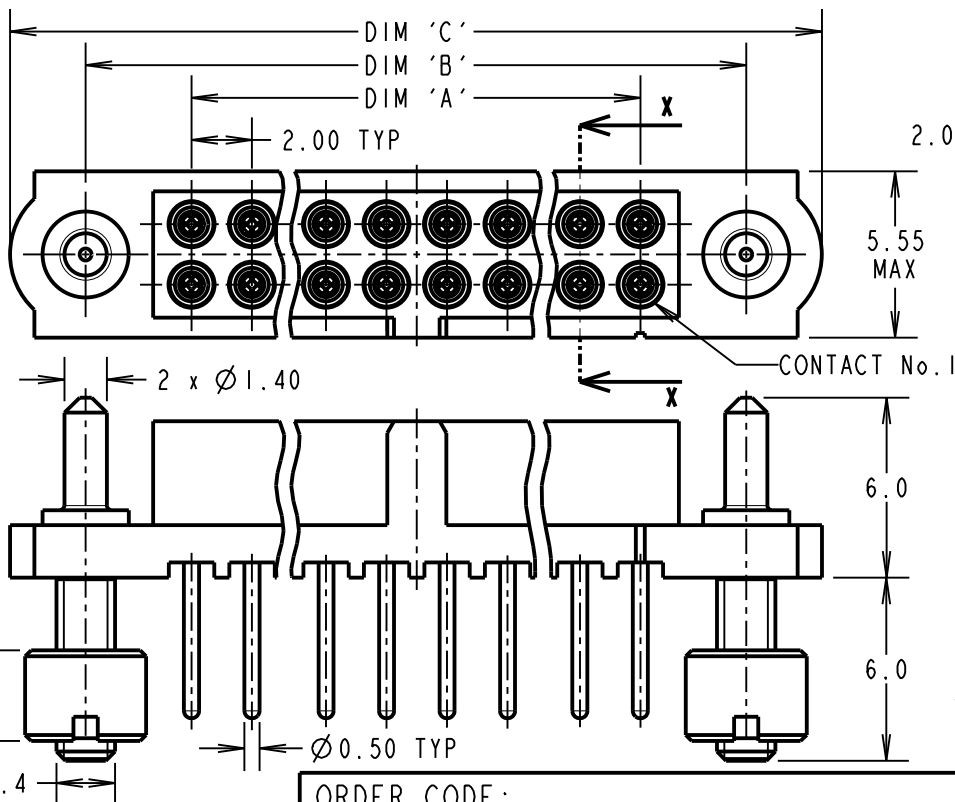

2 x M2x0.4

DIMENSION	CALCULATION
DIM 'A'	TOTAL No. OF CONTACTS - 2
DIM 'B'	TOTAL No. OF CONTACTS + 5
DIM 'C'	TOTAL No. OF CONTACTS + 10

EXAMPLE: CONNECTOR WITH 20 CONTACTS, GOLD CLIP AND 100% TIN OVER NICKEL SHELL, M80-4T22042FJ

DIM 'A' = 18.00mm, DIM 'B' = 25.00mm, DIM 'C' = 30.00mm

ORDER CODE:

M80-4T2XXXXFJ

TOTAL No. OF CONTACTS
 04 TO 50
 (EVEN NUMBERS ONLY)

FINISH

- 01 - GOLD CLIP, TIN/LEAD SHELL
- 05 - GOLD CLIP, GOLD SHELL
- 42 - GOLD CLIP, 100% TIN OVER NICKEL SHELL

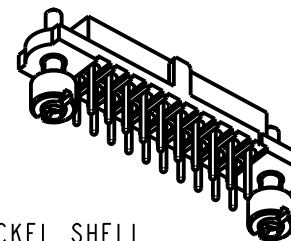

MGP	2	10.09.12	11761
NAME	ISS.	DATE	C/NOTE
APPROVED: MGP			
CHECKED: SB			
DRAWN: R.ADDE			
CUSTOMER REF.:			
ASSEMBLY DRG:			

HARWIN

www.harwin.com
 technical@harwin.com

THIS DRAWING AND ANY INFORMATION OR DESCRIPTIVE MATTER SET OUT HEREON ARE CONFIDENTIAL AND COPYRIGHT PROPERTY OF THE HARWIN GROUP AND MUST NOT BE DISCLOSED, LOANED, COPIED OR USED FOR MANUFACTURING, TENDERING OR FOR ANY OTHER PURPOSE WITHOUT THEIR WRITTEN PERMISSION.

TOLERANCES
 X. = ±1mm
 X.X = ±0.25mm
 X.XX = ±0.10mm
 X.XXX = ±0.01mm
 ANGLES = ±5°
 UNLESS STATED

MATERIAL:
 SEE ABOVE
FINISH: SEE ABOVE
S/AREA: mm²

TITLE: DATAMATE J-TEK FEMALE VERT 4.5mm PC-TAIL ASSY WITH GUIDE + BOARD MOUNT

DRAWING NUMBER:

M80-4T2XXXXFJ

SHT
 2 OF 2