

THIS SKETCH IS FOR QUOTATION PURPOSES ONLY

FINISH
(TICK APPLICABLE):

- 100% TIN
- GOLD

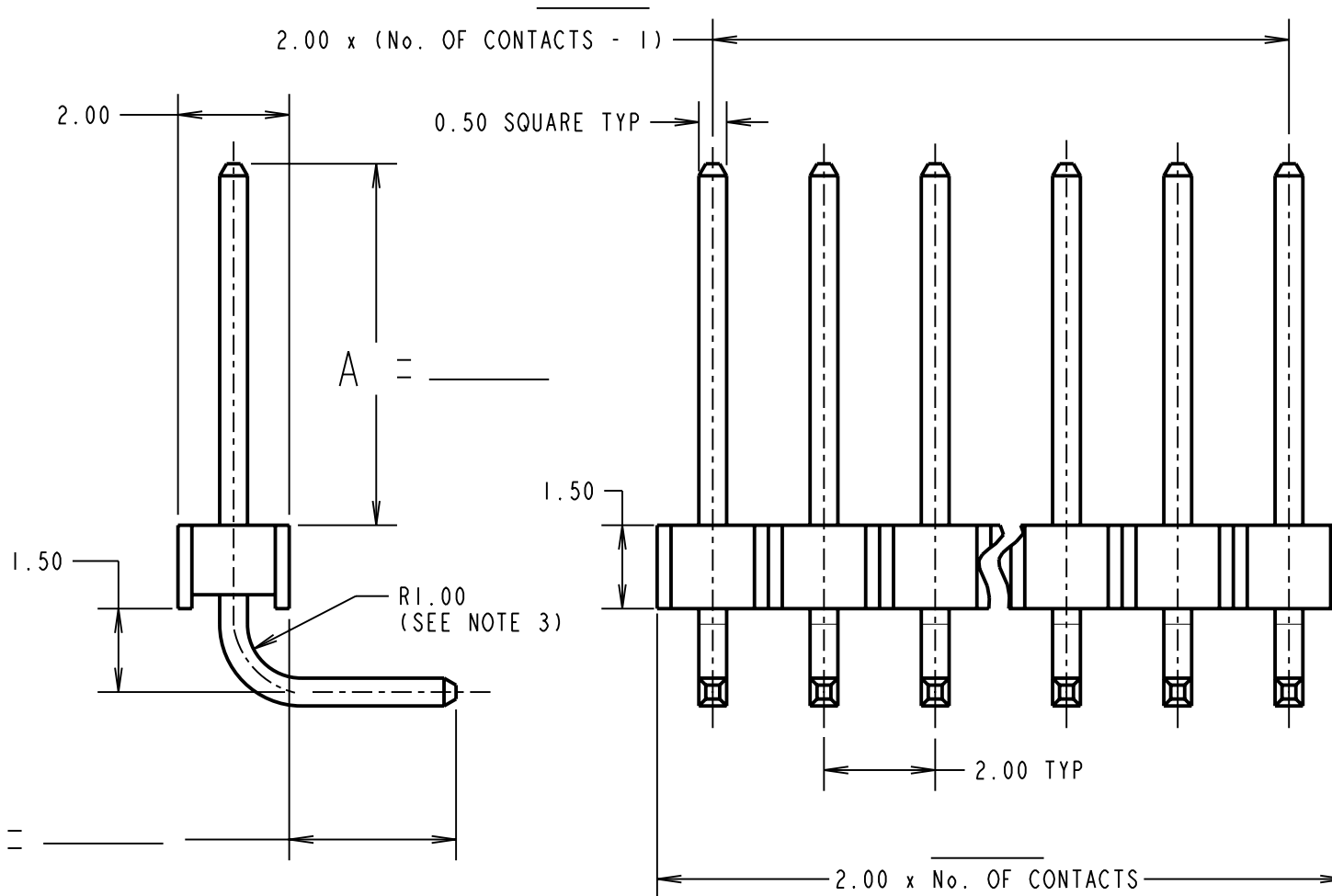

- NOTES:
1. MAXIMUM PERMISSIBLE OUT OF SQUARE OF PIN TO MOULDING TO BE 0.10mm IN ANY DIRECTION.
 2. CONTACT LEG VARIATION ON COMPLETE ASSEMBLY NOT TO EXCEED 0.10mm.
 3. RADIUS TO BE CONSISTENT WITHIN 0.25mm FROM PIN TO PIN.

SPECIFICATION:
 MATERIAL:
 MOULDING = HIGH TEMPERATURE NYLON 6T, UL94V-0, BLACK
 PINS = PHOSPHOR BRONZE
 FINISH:
 PINS: SEE BOX
 ELECTRICAL:
 CURRENT RATING = 1A MAX
 CONTACT RESISTANCE = 30 mΩ MAX
 INSULATION RESISTANCE = 100 MΩ MIN
 DIELECTRIC STRENGTH = 650V AC/DC
 ENVIRONMENTAL:
 TEMPERATURE RANGE = -40°C TO +105°C
 PACKING:
 BAG

DATE OF SKETCH:

REQUESTED BY:

No. OF CONTACTS PER ROW:

HARWIN

THIS DRAWING AND ANY INFORMATION OR DESCRIPTIVE MATTER SET OUT HEREON ARE CONFIDENTIAL AND COPYRIGHT PROPERTY OF THE HARWIN GROUP AND MUST NOT BE DISCLOSED, LOANED, COPIED OR USED FOR MANUFACTURING, TENDERING OR FOR ANY OTHER PURPOSE WITHOUT THEIR WRITTEN PERMISSION.

TOLERANCES
 X. = ±1mm
 X.X = ±0.25mm
 X.XX = ±0.10mm
 X.XXX = ±0.01mm
 ANGLES = ±5°
 UNLESS STATED

TITLE:
 2.00mm PITCH SIL HORIZONTAL PC TAIL PIN HEADER VARIANT

DRAWING No.: M22- _____ H _____

HARWIN INC U.S.A. TEL: (812) 542 2540 FAX: (812) 542 2541	HARWIN PLC U.K. TEL: 023 9231 4545 FAX: 023 9231 4590	HARWIN PTE SINGAPORE TEL: 65 6779 4909 FAX: 65 6779 3868
--	--	---