

Features

- Floating channel designed for bootstrap operation
- Fully operational to +600V
- Tolerant to negative transient voltage – dV/dt immune
- Gate drive supply range from 5V to 20V
- Undervoltage lockout for both channels
- 3.3V, 5V and 15V input logic compatible
- Matched propagation delay for both channels
- Outputs in phase with inputs
- Lower di/dt gate driver for better noise immunity
- Leadfree, RoHS compliant
- Automotive qualified*

Typical Applications

- Automotive motor drives
- Servo drives
- Micro inverter drives
- General purpose three phase inverters

Product Summary

V_{OFFSET}	600V Max
V_{OUT}	5V – 20V
$I_{\text{O+}} \& I_{\text{O-}}$ (typical)	200mA / 350mA
$t_{\text{ON}} \& t_{\text{OFF}}$ (typical)	220ns / 200ns
Delay Matching	50ns

Package Options



8-Lead SOIC
AUIRS2301S

Typical Connection Diagram

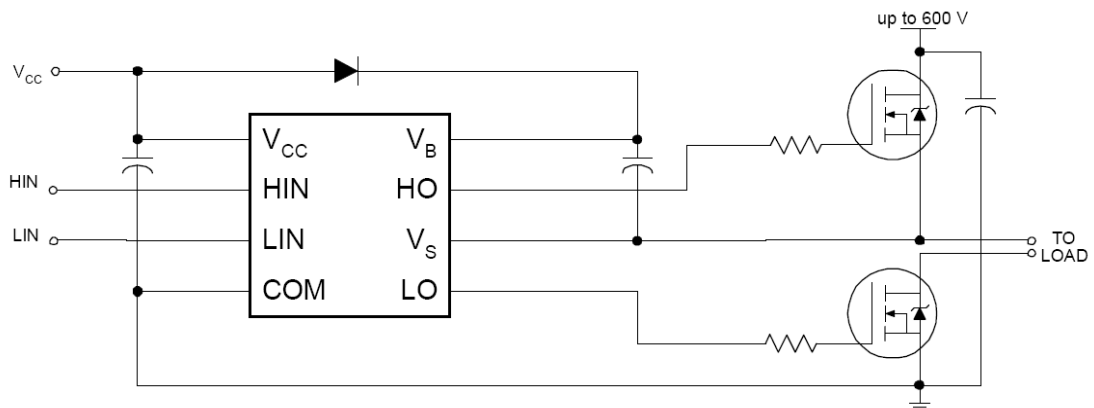

(Refer to Lead Assignments for correct pin configuration). This diagram shows electrical connections only. Please refer to our Application Notes and DesignTips for proper circuit board layout.

Table of Contents	Page
Typical Connection Diagram	1
Description	3
Feature Comparison	3
Qualification Information	4
Absolute Maximum Ratings	5
Recommended Operating Conditions	5
Dynamic Electrical Characteristics	6
Static Electrical Characteristics	6
Functional Block Diagram	7
Input/output Timing Diagram	8
Lead Definitions	9
Lead Assignments	9
Application Information and Additional Details	10
Parameter Temperature Trends	12 - 14
Package Details	15
Tape and Reel Details	16
Part Marking Information	17
Ordering Information	17
Important Notice	18

Description

The AUIRS2301S is a high voltage, high speed power MOSFET and IGBT driver with independent high- and low-side referenced output channels. Proprietary HVIC and latch immune CMOS technologies enable ruggedized monolithic construction. The logic input is compatible with standard CMOS or LSTTL output, down to 3.3V logic. The output drivers feature a high pulse current buffer stage. The floating channel can be used to drive an N-channel power MOSFET or IGBT in the high-side configuration which operates up to 600V.

Qualification Information[†]

Qualification Level		Automotive (per AEC-Q100 ^{††})
		Comments: This family of ICs has passed an Automotive qualification. IR's Industrial and Consumer qualification level is granted by extension of the higher Automotive level.
Moisture Sensitivity Level		MSL3 ^{†††} 260°C (per IPC/JEDEC J-STD-020)
ESD	Machine Model	Class M2 (Pass +/-200V) (per AEC-Q100-003)
	Human Body Model	Class H1C (Pass +/-2000V) (per AEC-Q100-002)
	Charged Device Model	Class C5 (Pass +/-1000V) (per AEC-Q100-011)
IC Latch-Up Test		Class II , Level B (per AEC-Q100-004)
RoHS Compliant		Yes

† Qualification standards can be found at International Rectifier's web site <http://www.irf.com/>

†† Exceptions to AEC-Q100 requirements are noted in the qualification report.

††† Higher MSL ratings may be available for the specific package types listed here. Please contact your International Rectifier sales representative for further information.

Absolute Maximum Ratings

Absolute Maximum Ratings indicate sustained limits beyond which damage to the device may occur. All voltage parameters are absolute voltages referenced to COM. The thermal resistance and power dissipation ratings are measured under board mounted and still air conditions.

Symbol	Definition	Min.	Max.	Units
V_B	High-side floating absolute voltage	-0.3	625	V
V_S	High-side floating supply offset voltage	$V_B - 25$	$V_B + 0.3$	
V_{HO}	High-side floating output voltage	$V_S - 0.3$	$V_B + 0.3$	
V_{CC}	Low-side and logic fixed supply voltage	-0.3	25	
V_{LO}	Low-side output voltage	-0.3	$V_{CC} + 0.3$	
V_{IN}	Logic input voltage (HIN & LIN)	COM -0.3	$V_{CC} + 0.3$	
dV_S/dt	Allowable offset supply voltage transient	—	50	V/ns
P_D	Package power dissipation @ $T_A \leq 25^\circ\text{C}$	—	0.625	W
R_{thJA}	Thermal resistance, junction to ambient	—	200	$^\circ\text{C}/\text{W}$
T_J	Junction temperature	—	150	$^\circ\text{C}$
T_S	Storage temperature	-50	150	
T_L	Lead temperature (soldering, 10 seconds)	—	300	

Recommended Operating Conditions

The input/output logic timing diagram is shown in Fig. 1. For proper operation the device should be used within the recommended conditions. The V_S offset rating is tested with all supplies biased at 15V differential.

Symbol	Definition	Min.	Max.	Units
V_B	High-side floating supply absolute voltage	$V_S + 5$	$V_S + 20$	V
V_S	High-side floating supply offset voltage	† 1	600	
V_{HO}	High-side floating output voltage	V_S	V_B	
V_{CC}	Low-side and logic fixed supply voltage	5	20	
V_{LO}	Low-side output voltage	0	V_{CC}	
V_{IN}	Logic input voltage (HIN & LIN)	COM	V_{CC}	
T_A	Ambient temperature	-40	125	$^\circ\text{C}$

†: Logic operational for V_S of -5 V to +600 V. Logic state held for V_S of -5 V to $-V_{BS}$.
 (Please refer to the Design Tip DT97 -3 for more details).

Static Electrical Characteristics

Unless otherwise noted, these specifications apply for an operating junction temperature range of $-40^{\circ}\text{C} \leq T_j \leq 125^{\circ}\text{C}$ with bias conditions of $V_{\text{BIAS}} (V_{\text{CC}}, V_{\text{BS}}) = 15\text{V}$. The V_{IL} , V_{IH} and I_{IN} parameters are referenced to COM and are applicable to the respective input leads: HIN and LIN. The V_{O} , I_{O} and R_{on} parameters are referenced to COM and are applicable to the respective output leads: HO and LO.

Symbol	Definition	Min	Typ	Max	Units	Test conditions
V_{IH}	Logic "1" input voltage	2.5	—	—	V	$V_{\text{CC}} = 10\text{V to } 20\text{V}$
V_{IL}	Logic "0" input voltage	—	—	0.8		
V_{OH}	High level output voltage, $V_{\text{BIAS}} - V_{\text{O}}$	—	—	0.2	V	$I_{\text{O}} = 2\text{mA}$
V_{OL}	Low level output voltage, V_{O}	—	—	0.1		
I_{LK}	Offset supply leakage current	—	—	50	μA	$V_{\text{B}} = V_{\text{S}} = 600\text{V}$
I_{QBS}	Quiescent V_{BS} supply current	60	160	260		$V_{\text{IN}} = 0\text{V or } 5\text{V}$
I_{QCC}	Quiescent V_{CC} supply current	60	160	260		$V_{\text{IN}} = 5\text{V}$
$I_{\text{IN+}}$	Logic "1" input bias current	—	5	20		$V_{\text{IN}} = 0\text{V}$
$I_{\text{IN-}}$	Logic "0" input bias current	—	—	5		
$V_{\text{CCUV+}}$ $V_{\text{BSUV+}}$	V_{CC} and V_{BS} supply undervoltage positive going threshold	3.3	4.1	5	V	
$V_{\text{CCUV-}}$ $V_{\text{BSUV-}}$	V_{CC} and V_{BS} supply undervoltage negative going threshold	3	3.8	4.7		
V_{CCUVH} V_{BSUVH}	Hysteresis	0.1	0.3	—		
$I_{\text{O+}}$	Output high short circuit pulsed current	—	200	—	mA	$V_{\text{O}} = 0\text{V},$ $\text{PW} \leq 10\mu\text{s}$
$I_{\text{O-}}$	Output low short circuit pulsed current	—	350	—		$V_{\text{O}} = 15\text{V},$ $\text{PW} \leq 10\mu\text{s}$

Dynamic Electrical Characteristics

Unless otherwise noted, these specifications apply for an operating junction temperature range of $-40^{\circ}\text{C} \leq T_j \leq 125^{\circ}\text{C}$ with bias conditions of $V_{\text{BIAS}} (V_{\text{CC}}, V_{\text{BS}}) = 15\text{V}$, $C_{\text{L}} = 1000\text{pF}$.

Symbol	Definition	Min	Typ	Max	Units	Test conditions
t_{on}	Turn-on propagation delay	—	220	300	ns	$V_{\text{S}} = 0\text{V}$
t_{off}	Turn-off propagation delay	—	200	280		$V_{\text{S}} = 0\text{V or } 600\text{V}$
MT	Delay matching, HS & LS turn-on/off	—	0	50		
t_{r}	Turn-on rise time	—	130	220		$V_{\text{S}} = 0\text{V}$
t_{f}	Turn-off fall time	—	50	80		

Functional Block Diagram:

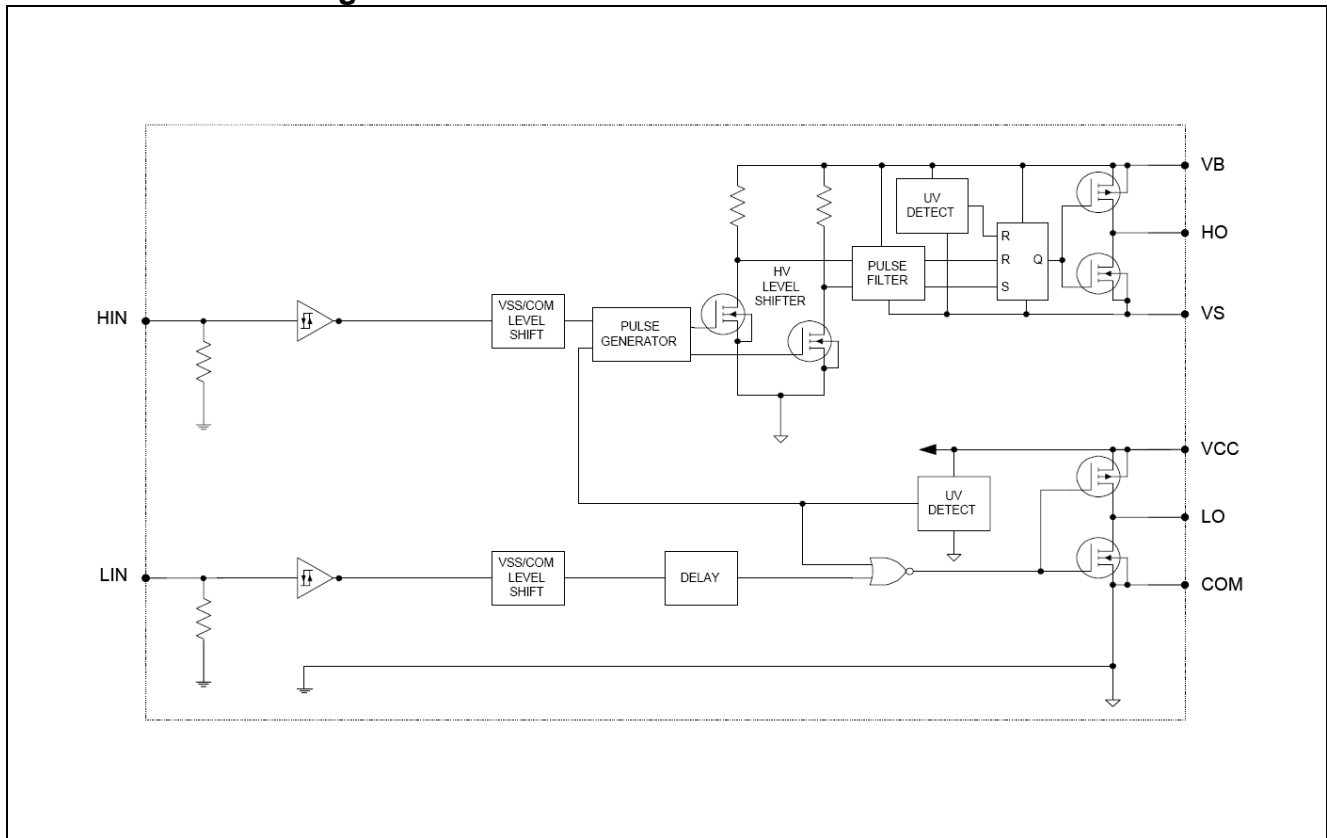

Input/Output Pin Equivalent Circuit Diagrams:

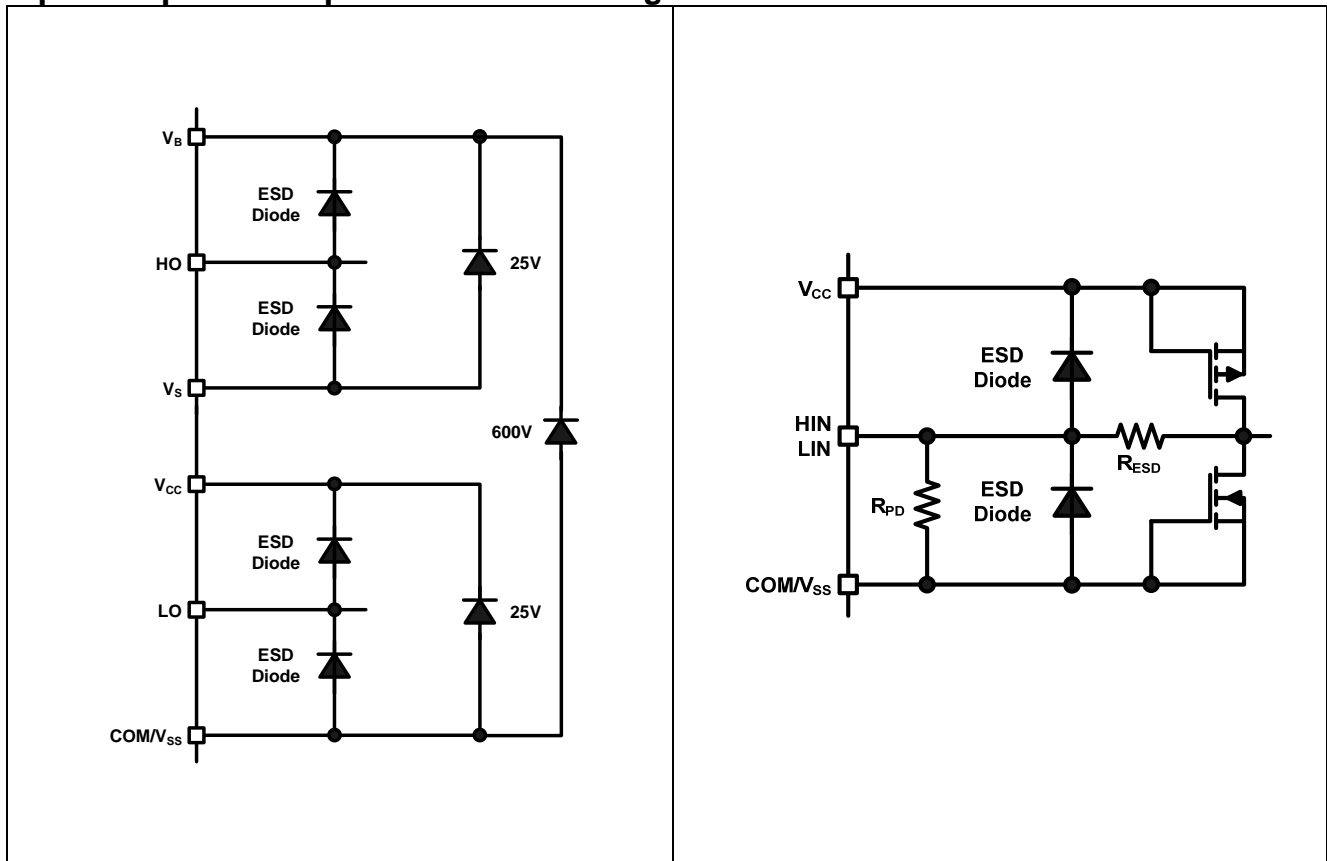

Lead Definitions:

PIN#	Symbol	Description
1	V _{CC}	Low-side and logic fixed supply
2	HIN	Logic input for high-side gate driver outputs (HO), in phase with HO
3	LIN	Logic input for low-side gate driver outputs (LO), in phase with LO
4	COM	Low-side return
5	LO	Low-side gate drive output
6	V _S	High-side floating supply return
7	HO	High-side gate drive output
8	V _B	High-side floating supply

Lead Assignments

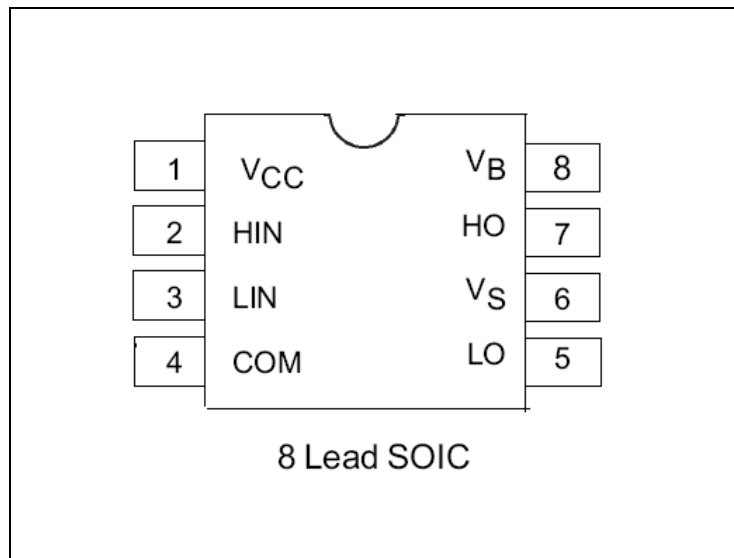

Application Information and Additional Details

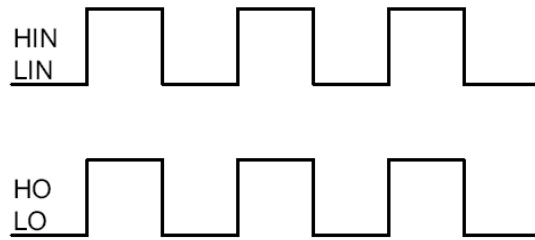

Figure 1: Input/Output Timing Diagram

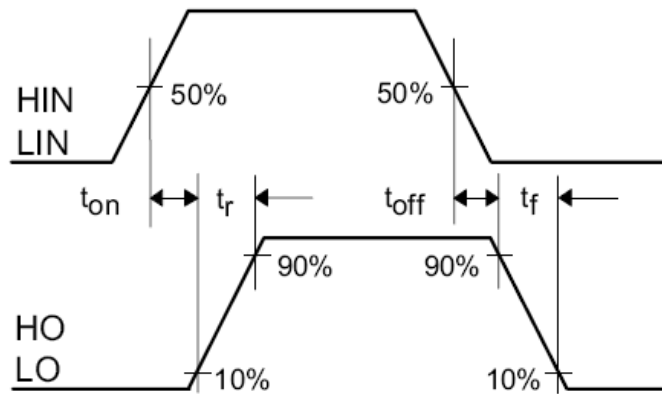

Figure 2: Switching Time Waveform Definitions

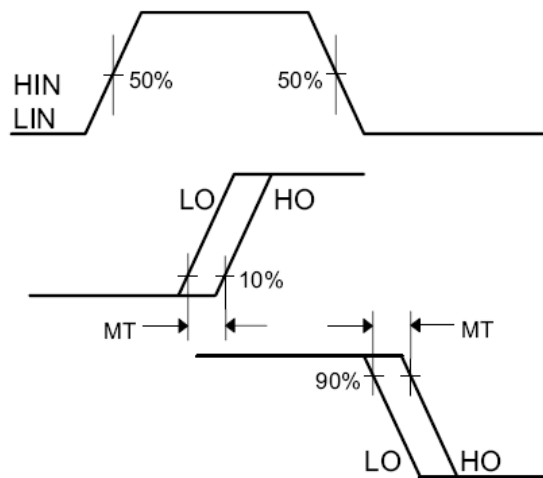

Figure 3: Delay Matching Waveform Definitions

Tolerability to Negative V_s Transients

The AUIRS2301S has been seen to withstand negative V_s transient conditions on the order of -25V for a period of 100 ns (V_{BIAS} (V_{CC} , V_{BS}) = 15V and $T_A = 25^\circ\text{C}$).

An illustration of the AUIRS2301S performance can be seen in Figure 4.

Even though the AUIRS2301S has been shown able to handle these negative V_s transient conditions, it is highly recommended that the circuit designer always limit the negative V_s transients as much as possible by careful PCB layout and component use.

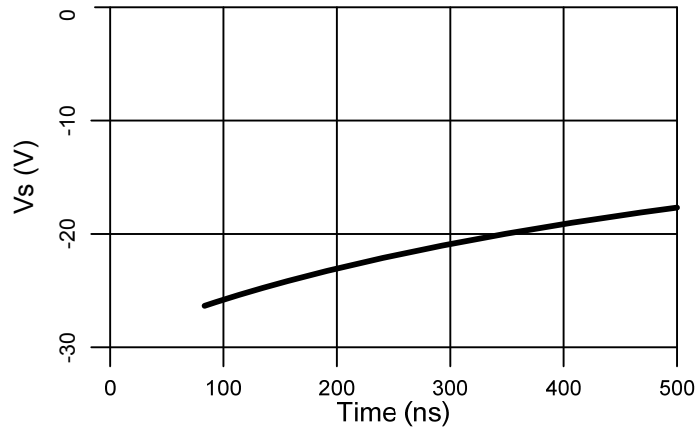

Figure 4: - V_s Transient results

Parameter Temperature Trends

Figures illustrated in this chapter provide information on the experimental performance of the AUIRS2301S HVIC. The line plotted in each figure is generated from actual lab data. A large number of individual samples were tested at three temperatures (-40 °C, 25 °C, and 125 °C) in order to generate the experimental curve. The line consists of three data points (one data point at each of the tested temperatures) that have been connected together to illustrate the understood trend. The individual data points on the Typ. curve were determined by calculating the averaged experimental value of the parameter (for a given temperature).

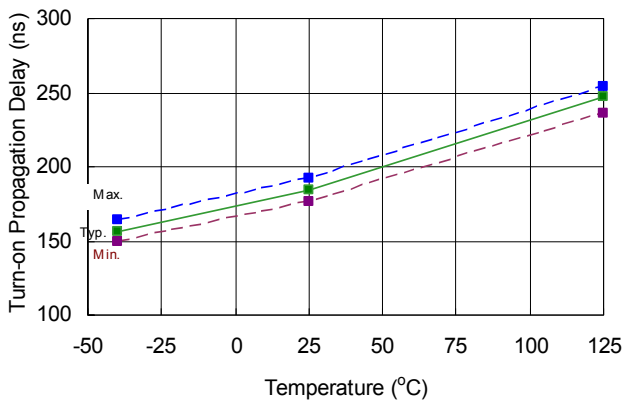

Figure 5: T_{ON} vs. temperature

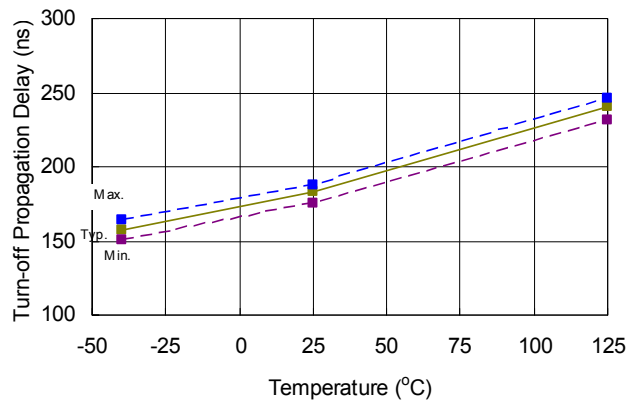

Figure 6: T_{OFF} vs. temperature

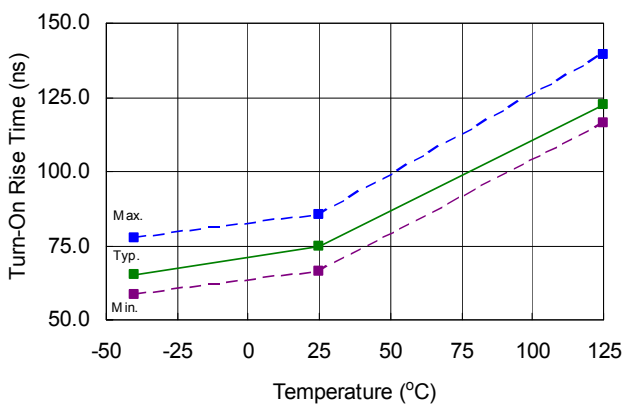

Figure 7: T_R vs. temperature

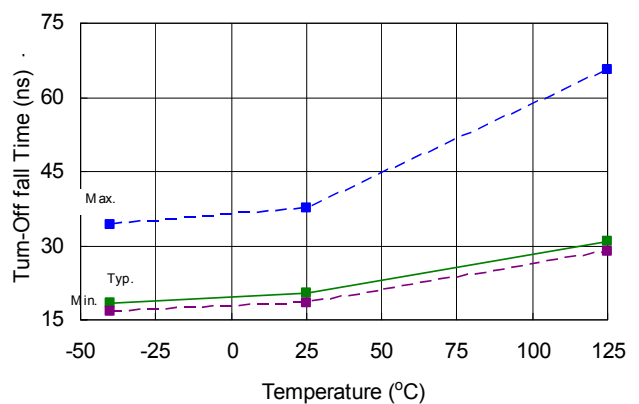

Figure 8: T_F vs. temperature

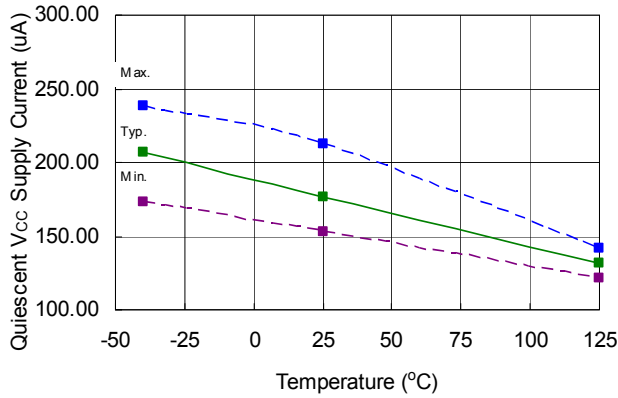

Figure 9: V_{CC} supply current vs. temperature

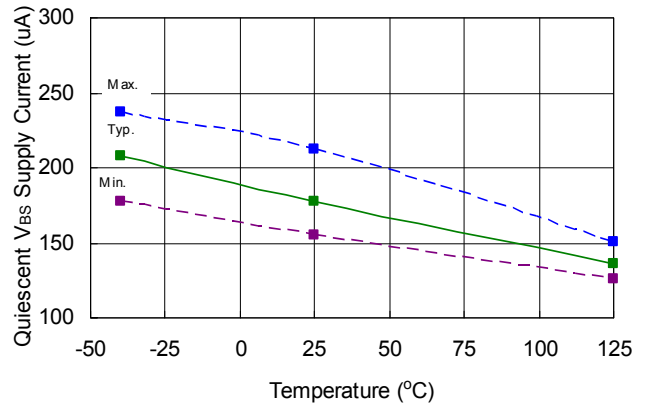

Figure 10: V_{BS} supply current vs. temperature

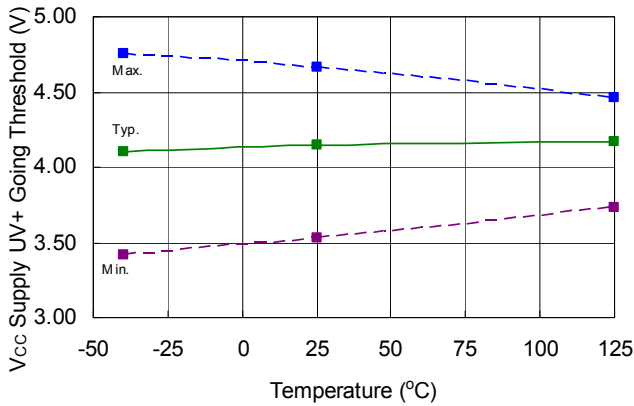

Figure 11: V_{CCUV+} vs. temperature

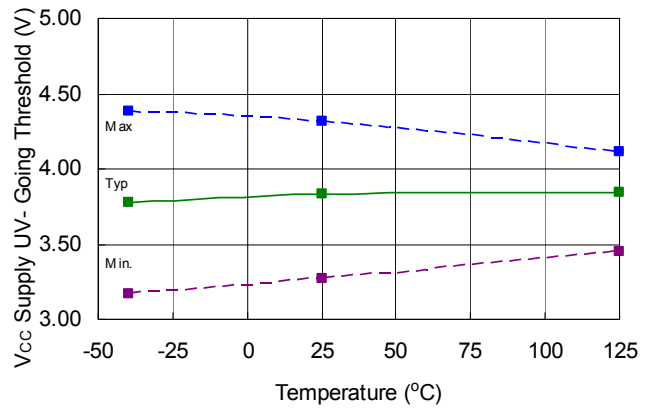

Figure 12: V_{CCUV-} vs. temperature

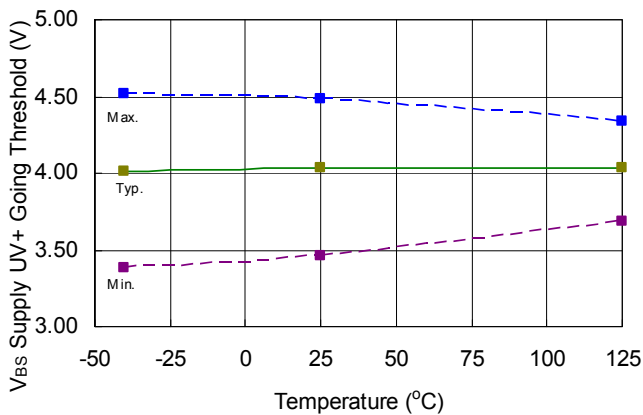

Figure 13: V_{BSUV+} vs. temperature

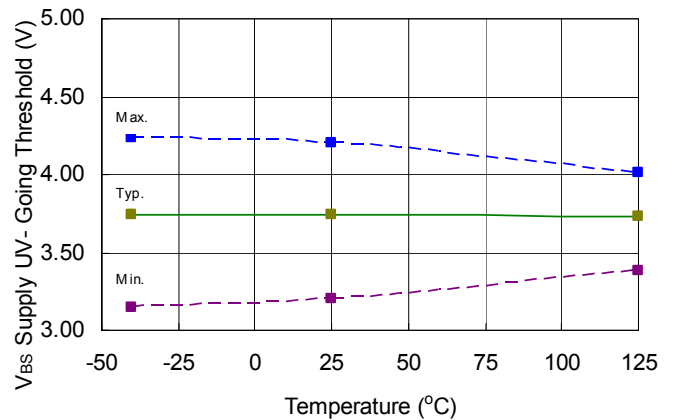

Figure 14: V_{BSUV-} vs. temperature

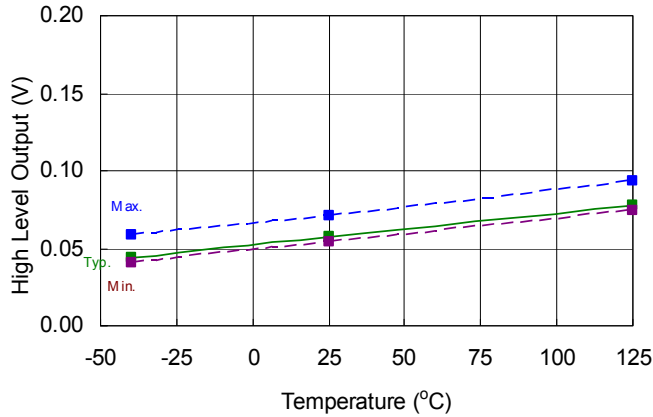

Figure 15: V_{OH} ($I_O = 2mA$) vs. temperature

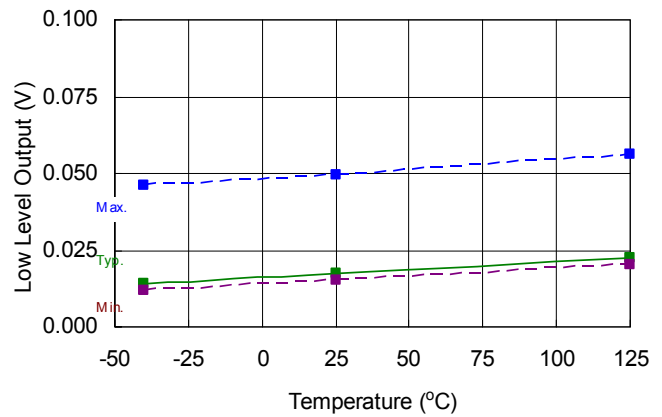

Figure 16: V_{OL} ($I_O = 2mA$) vs. temperature

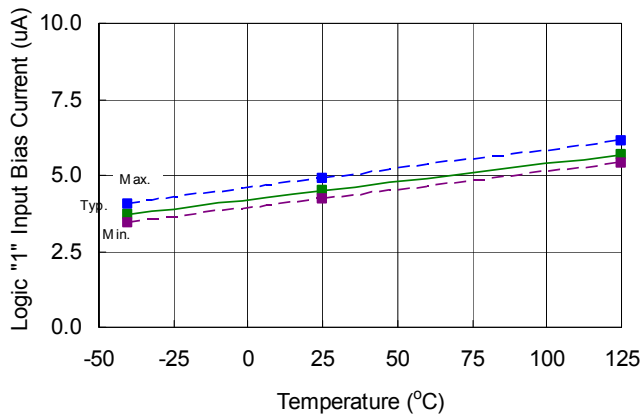

Figure 17: Logic "1" input Bias current vs. temperature

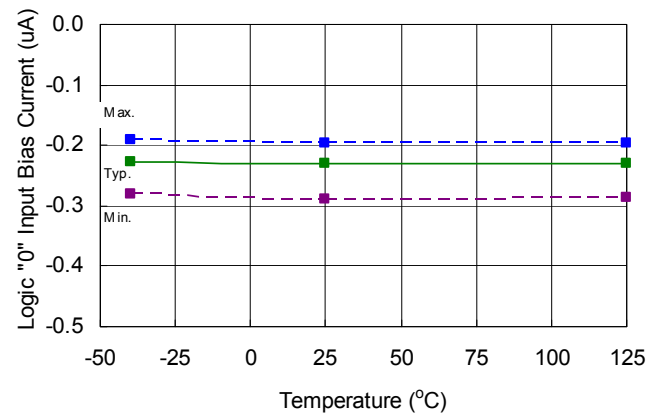

Figure 18: Logic "0" input bias current vs. temperature

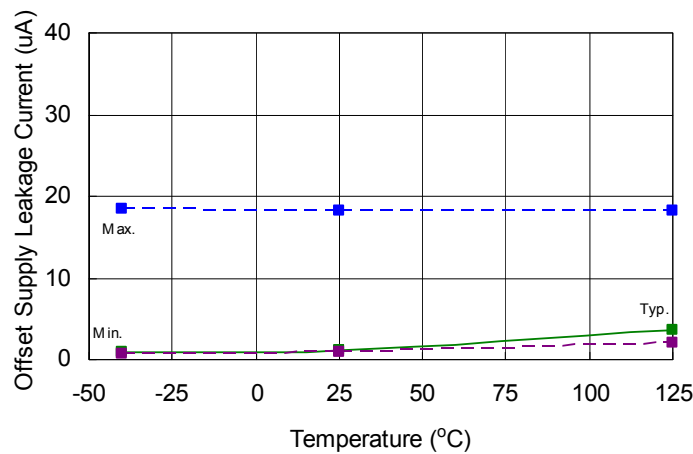
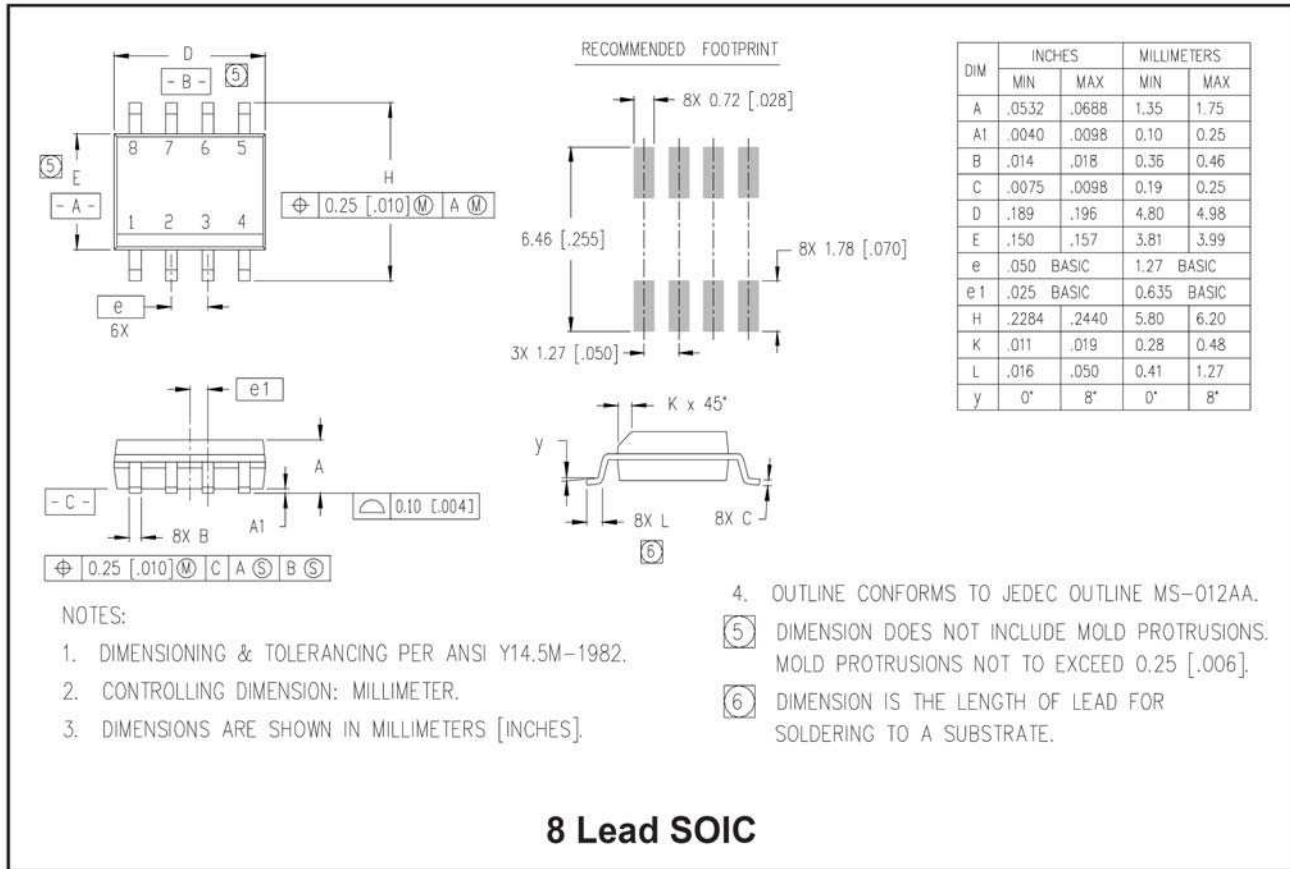
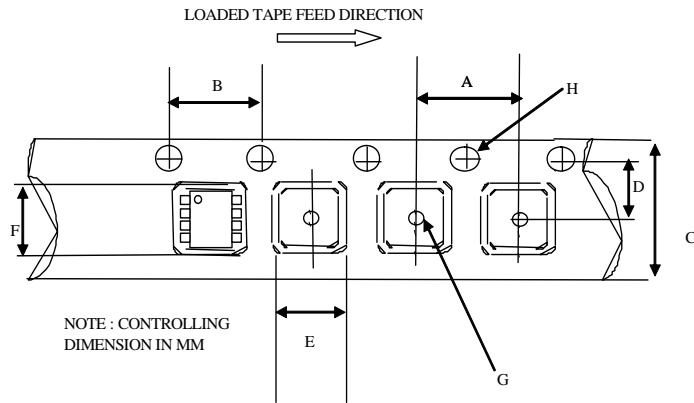

Figure 19: Offset leakage current vs. temperature

Package Details



Tape and Reel Details



CARRIER TAPE DIMENSION FOR 8SOICN

Code	Metric		Imperial	
	Min	Max	Min	Max
A	7.90	8.10	0.311	0.318
B	3.90	4.10	0.153	0.161
C	11.70	12.30	0.46	0.484
D	5.45	5.55	0.214	0.218
E	6.30	6.50	0.248	0.255
F	5.10	5.30	0.200	0.208
G	1.50	n/a	0.059	n/a
H	1.50	1.60	0.059	0.062

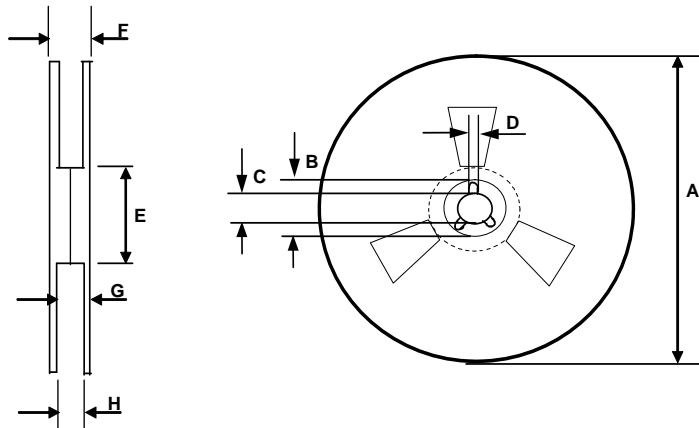

REEL DIMENSIONS FOR 8SOICN

Code	Metric		Imperial	
	Min	Max	Min	Max
A	329.60	330.25	12.976	13.001
B	20.95	21.45	0.824	0.844
C	12.80	13.20	0.503	0.519
D	1.95	2.45	0.767	0.096
E	98.00	102.00	3.858	4.015
F	n/a	18.40	n/a	0.724
G	14.50	17.10	0.570	0.673
H	12.40	14.40	0.488	0.566

Part Marking Information

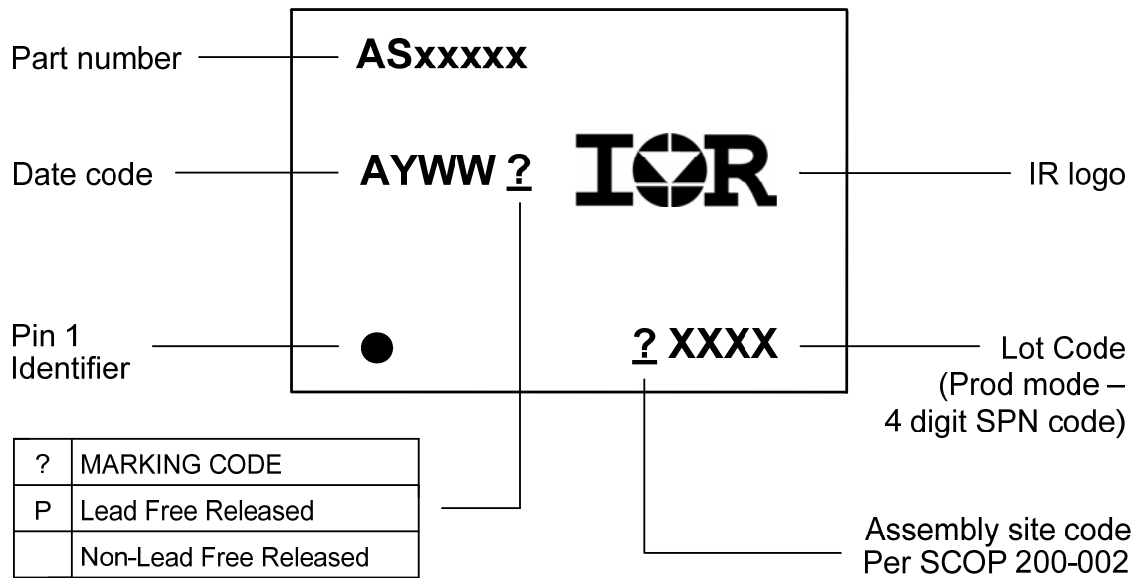

Ordering Information

Base Part Number	Package Type	Standard Pack		Complete Part Number
		Form	Quantity	
AUIRS2301	SOIC8	Tube/Bulk	95	AUIRS2301S
		Tape and Reel	2500	AUIRS2301STR

IMPORTANT NOTICE

Unless specifically designated for the automotive market, International Rectifier Corporation and its subsidiaries (IR) reserve the right to make corrections, modifications, enhancements, improvements, and other changes to its products and services at any time and to discontinue any product or services without notice. Part numbers designated with the "AU" prefix follow automotive industry and / or customer specific requirements with regards to product discontinuance and process change notification. All products are sold subject to IR's terms and conditions of sale supplied at the time of order acknowledgment.

IR warrants performance of its hardware products to the specifications applicable at the time of sale in accordance with IR's standard warranty. Testing and other quality control techniques are used to the extent IR deems necessary to support this warranty. Except where mandated by government requirements, testing of all parameters of each product is not necessarily performed.

IR assumes no liability for applications assistance or customer product design. Customers are responsible for their products and applications using IR components. To minimize the risks with customer products and applications, customers should provide adequate design and operating safeguards.

Reproduction of IR information in IR data books or data sheets is permissible only if reproduction is without alteration and is accompanied by all associated warranties, conditions, limitations, and notices. Reproduction of this information with alterations is an unfair and deceptive business practice. IR is not responsible or liable for such altered documentation. Information of third parties may be subject to additional restrictions.

Resale of IR products or serviced with statements different from or beyond the parameters stated by IR for that product or service voids all express and any implied warranties for the associated IR product or service and is an unfair and deceptive business practice. IR is not responsible or liable for any such statements.

IR products are not designed, intended, or authorized for use as components in systems intended for surgical implant into the body, or in other applications intended to support or sustain life, or in any other application in which the failure of the IR product could create a situation where personal injury or death may occur. Should Buyer purchase or use IR products for any such unintended or unauthorized application, Buyer shall indemnify and hold International Rectifier and its officers, employees, subsidiaries, affiliates, and distributors harmless against all claims, costs, damages, and expenses, and reasonable attorney fees arising out of, directly or indirectly, any claim of personal injury or death associated with such unintended or unauthorized use, even if such claim alleges that IR was negligent regarding the design or manufacture of the product.

IR products are neither designed nor intended for use in military/aerospace applications or environments unless the IR products are specifically designated by IR as military-grade or "enhanced plastic." Only products designated by IR as military-grade meet military specifications. Buyers acknowledge and agree that any such use of IR products which IR has not designated as military-grade is solely at the Buyer's risk, and that they are solely responsible for compliance with all legal and regulatory requirements in connection with such use.

IR products are neither designed nor intended for use in automotive applications or environments unless the specific IR products are designated by IR as compliant with ISO/TS 16949 requirements and bear a part number including the designation "AU". Buyers acknowledge and agree that, if they use any non-designated products in automotive applications, IR will not be responsible for any failure to meet such requirements.

For technical support, please contact IR's Technical Assistance Center
<http://www.irf.com/technical-info/>

WORLD HEADQUARTERS:
233 Kansas St., El Segundo, California 90245
Tel: (310) 252-7105

Revision History

Date	Comment
11/18/08	New template, standard pack quantity corrected
12/1/08	Removed Typical Applications section from the first page Changed I _{O+} & I _{O-} text from typ to min, min values were reported Updated all parameters to reflect the previously released Gen2 part, modifications can be made at a later date if need be Imported correct I/O diagrams
12/9/08	Added Pin# in lead assignment table and changed the order
2/6/09	Changed ESD/LU ratings to TBD pending data
3/3/09	Removed PDIP
3/4/09	Removed "Parameter Temp Trend" section (updated page number references as well) Modified page header to read "2301" in place of "2103" Changed IQCC from 50/120/190uA to 60/150/240uA Changed IQBS from 20/60/100uA to 60/150/240uA
6/2/09	Feature comparison removed on p3 Qual table updated
6/9/09	F front page: - HIGH AND LOW SIDE DRIVER in place of HALF BRIDGE DRIVER (no cross conduction prevention logic, no dead time). - "Logic and power ground ± 5V offset" sentence removed (only COM exists as ground pin). Page3: "designed for minimum driver cross-conduction" sentence erased. Page 11: added this page with section "Tolerability to Negative VS Transients" (APBU review)
7/2/09	Updated IQCC/IQBS UL to 260uA from 240uA
7/9/09	Changed the year to 2009 in footer Removed "()" in the part number in the description and file name Removed rows for PDIP in the Absolute Maximum Ratings Removed min spec on I _{O+} /I _{O-} since we don't test this parameter on ATE Deleted "SOIC8" from qual table
7/15/09	T _A max temp changed from 150 to 125
7/28/09	Remove preliminary sign (DR3 approved)
7/30/09	Application section added in front page
9/8/09	ESD class modified MM M2 (was M3 based on the incorrect ESD summary)
9/14/09	Added ESD passing voltages
1/13/11	Added parameter temperature trends, updated test condition to tri-temp and important notice
1/14/11	Revised I _O +/- to be typical value on front page