



Fortus® 360mc/400mc 3D Production System

User Guide

Part No. 107166-0012, Rev. A

Liability Statement

The information in this document is subject to change without notice. Stratasys, Inc. shall not be liable for errors contained herein or for incidental or consequential damages in connection with the furnishing, performance, or use of this material.

Stratasys, Inc. makes no warranty of any kind with regard to this material, including, but not limited to, the implied warranties of merchantability and fitness for a particular purpose. It is the responsibility of the system owner/ material buyer to determine that the Stratasys material is safe, lawful, and technically suitable for the intended application as well as identify the proper disposal (or recycling) method consistent with local environmental regulations. Except as provided in Stratasys' standard conditions of sale, Stratasys shall not be responsible for any loss resulting from any use of its products described herein.

Copyright Statement

This document is protected by copyright. All rights reserved. Its use, disclosure, and possession are restricted by an agreement with Stratasys per software copyright. No part of this document may be photocopied, reproduced or translated into another language without the prior written consent of Stratasys, Inc.

All drawings and information herein are the property of Stratasys Inc. All unauthorized use and reproduction is prohibited.

Trademark Acknowledgments

Stratasys, Insight, WaterWorks, and FORTUS are registered trademarks of Stratasys, Inc.

FORTUS 360mc, FORTUS 400mc, and FORTUS 900mc are trademarks and service marks of Stratasys Inc. in the United States and other countries.

FDM 360mc and FDM 400mc are registered trademarks and service marks of Stratasys Inc. in the United States and other countries.

Windows NT, Windows 2000, and Windows XP are registered trademarks of Microsoft Corporation.

Ultem* 9085 is a trademark of SABIC Innovative Plastics IP BV.

© Copyright 2014 Stratasys, Inc.
Publication Date: July, 2014

The FORTUS 360mc/400mc and FDM 360mc/400mc systems conform with the following standards, in accordance with the EU Machinery, Low Voltage and Electromagnetic Compatibility Directives: EU 2006/42/EC
EU 2006/95/EC
EU 2004/108/EC



About the FORTUS 360mc/400mc and FDM 360mc/400mc

Welcome to the Fortus 360mc/400mc™ and FDM 360mc/400mc™ 3D Production Systems which are referred to throughout this User Guide as the 360mc/400mc. These systems incorporate the latest in innovative technologies to provide you with precise prototypes from a CAD design. Stratasys' Fused Deposition Modeling (FDM) technology provides prototype parts, including internal features, that can be used to field-test form, fit, and function. The 360mc/400mc systems feature a servo/belt driven XY gantry with multiple high temperature modeling material capability.

Components of the 360mc/400mc Modeling System

- Insight Software Package
- A Computer Workstation (not sold by Stratasys)
- The 360mc/400mc Modeling Machine
- Modeling Material
- Support Material

System Highlights

- Envelope Size: 14 x 10 x 10 inch (355 x 254 x 254 mm)
- Material Bays: 1 model, 1 support
- Tips/Slice Heights:

Tip Type	Slice Height
ABSi Material Option/Upgrade	0.005 in. (0.127 mm)
ABS-M30 Material Option/Upgrade	0.007 in. (0.178 mm)
ABS-M30i Material Option/Upgrade	0.010 in. (0.254 mm)
ABS-ESD7	0.013 in. (0.330 mm)



Note: Material choice affects available tip size/slice height.

Available Options

Available Options	360mc	400mc
ABSi Material Option/Upgrade		X
ABS-M30 Material Option/Upgrade	X	X
ABS-M30i Material Option/Upgrade		X
ABS-ESD7		X
ASA Material Option/Upgrade	X	X
Nylon 12 Material Option/Upgrade	X	X
PC-ABS Material Option/Upgrade	X	X
PC Material Option/Upgrade	X	X
PC-ISO Material Option/Upgrade		X
Ultem* 9085 Material Option/Upgrade		X
PPSF Material Option/Upgrade		X
Large Envelope Option/Upgrade: Envelope upgrade to 16x14x16 inch (406x355x406 mm) Adds one (1) additional model material bay Adds one (1) additional support material bay Adds Material Auto-Changeover	X	X

About This Guide

This guide is your introduction to building prototypes using a Stratasys rapid prototype system. It is designed as a learning and reference tool that explains system operation in an easy to understand, step-by-step, process.

How to Use This Guide

This guide is divided into easy-to-follow chapters. The tabs allow you to quickly and easily find the information you want. You can read this user guide chapter by chapter or use the tabs, Table of Contents when you need to quickly find specific information. Keeping this user guide close to your system will efficiently allow you to troubleshoot and maintain the system.

Conventions Used in This Guide

The following conventions are used in this guide.

- When you see text in **this font**, it indicates a menu item that can be selected from the Operator Panel Screen. For example, select **Build Last Job**.
- If you see text in **BOLD CAPS** it indicates that this is a key located on the Operator Panel keypad. For example, From the Main Menu select **Build Job** and press **ENTER**.
- If you see boxed blue text, it indicates that this information is being shown on the Operator Panel Screen. For example:

```
Build Job..          |*Tips: Model T16
>Operator Control.. |*      Support T16
Modeler Status..
Maintenance..
```

Table of Contents

Chapter 1: Service and Support	1-1
Service	1-1
Software Support	1-1
Safety Instructions	1-2
Hazard Types	1-2
Product Safety Signs	1-3
Specific Safety Practices	1-4
Guard Door Interlocks	1-5
General Safety Practices	1-5
Chapter 2: Setup and Installation	2-1
General Information	2-1
Prepare Your Facility for Installation	2-1
Identifying Your System	2-1
Basic Setup	2-2
Making the Network Connection	2-2
Making the External Air Connection	2-2
Making the Power Cable Connection	2-2
Network Setup	2-3
Configuring the Network	2-3
Setting the IP Address	2-4
Moving the System	2-5
Chapter 3: System Components	3-1
System Protection	3-1
Main Circuit Breaker	3-1
Thermal Cut-Out Fuses	3-1
UPS	3-1
If power is lost to the modeler	3-2
During normal system power-down	3-2
Access Doors and Panels	3-2
Top Door and Top Hood	3-3
Oven Door	3-3
Canister Bay Doors	3-3
Right Side Door - Upper	3-4
Right Side Door - Lower	3-4
Left Side Door - Upper	3-4
Left Side Door - Lower	3-4
Gantry Area (XY Table)	3-5
Opening the Top Door and Top Hood	3-5
XY Gantry Assembly	3-5
Head Assembly	3-6
Head Maintenance Bracket	3-6

Modeling Materials and Tips	3-8
Materials	3-8
Materials Used	3-8
Materials Compatibility	3-8
Liquefier Tips	3-9
Liquefier Tips and Slice Heights	3-9
Tip Compatibility & Selection	3-9
Tip Identification	3-12
Oven Bay	3-13
Oven Door	3-13
Oven Components	3-13
Oven Lamps	3-13
The Platen	3-14
Tip Cleaning Assembly	3-14
Z Stage	3-15
Canister Bay	3-16
Accessing the Bays	3-16
Canister Bay Components	3-16
SmartSpool System	3-18
Vacuum and Air Dryer Systems	3-20
On Board Vacuum System	3-20
On Board Air Dryer System	3-20
Chapter 4: Operating the System	4-1
Basic User Interface and Operations	4-1
Using the Keypad	4-2
Screen Symbols	4-3
Powering Up the System	4-3
Powering Down the System	4-4
Basic Job Build Tasks	4-4
Before a Job Build	4-4
Select a Job to Build	4-6
Build Job Warnings	4-7
Information Available During a Build	4-9
Pausing or Aborting a Job	4-9
After a Job Build	4-10
Removing Supports	4-11
Breakaway Support Material	4-11
Soluble Release Support Material	4-11
Support Material for PPSF Parts	4-11
Material, Canisters, and Liquefier Tips	4-13
Unloading Material from the Liquefier Tips	4-13
Removing Canisters	4-14
Canister Installation	4-15
Loading Material to the Liquefier Tips	4-18
Canister Auto Change-over	4-20

Handling/Storing Canisters _____	4-21
Changing Tips or Material Type _____	4-22
Working with the Job Queues _____	4-29
Change Modeler Default Values _____	4-30
Display Units _____	4-30
Part Build Location _____	4-31
System Status _____	4-32
Temperature Status _____	4-32
Odometer Status _____	4-32
Material Status _____	4-33
System Software Version _____	4-34
Sensor, System, or UPS Status _____	4-34
Miscellaneous Operating Tasks _____	4-35
Oven Temperature Control _____	4-35
Operator Control of Head and Z Stage Movement _____	4-36
Chapter 5: Operating Insight _____	5-1
Getting Started with Insight _____	5-1
Starting Insight _____	5-1
Opening an STL File _____	5-1
Modeler Setup - Insight _____	5-2
Configure Your Modeler _____	5-2
Part Build Parameters _____	5-3
Preparing the Model - Insight _____	5-4
Orienting the Part in the Build Envelope _____	5-4
Slicing the Part _____	5-5
Building Supports and a Base for the Part _____	5-5
Saving the Job File _____	5-5
Creating Toolpaths _____	5-5
Saving the Toolpath (CMB file) _____	5-6
Flag Button Shortcut _____	5-6
Sending a Part to the Modeler _____	5-7
Chapter 6: Calibration _____	6-1
Automatic Calibration _____	6-1
Auto Z Stage Zero Calibration _____	6-1
Auto Tip-to-Tip Calibration (AutoCal Tip Offset) _____	6-2
XY and Z Tip Offset Calibration _____	6-2
Manual Calibration _____	6-6
Manual Z Stage Zero _____	6-6
Auto Z Stage Zero Calibration - Manual Start _____	6-8
Auto Tip-Tip Calibration (AutoCal Tip Offset) - Manual Start _____	6-9
XY and Z Tip Offset - Manual Start _____	6-10
Chapter 7: System Maintenance _____	7-1
Updating Controller Software _____	7-1

Web Method (preferred method) _____	7-1
CD Method (alternate method) _____	7-2
Placing System in Receive Software Upgrade Mode _____	7-3
Maintenance Schedule _____	7-3
Daily Maintenance _____	7-4
Clean the Platen _____	7-4
Empty the Purge Waste Bucket _____	7-4
Weekly Maintenance _____	7-5
Vacuum the Build Envelope _____	7-5
Clean/Inspect Tip Wipe Assembly _____	7-5
Quarterly Maintenance _____	7-8
Inspect the Platen O-Ring _____	7-8
Clean the Vacuum System In-Line Filter and Jar _____	7-8
Clean the Tip Sensor Plunger _____	7-9
As Needed Maintenance _____	7-9
Upgrading Software or Entering a System Code _____	7-9
Platen Flatness Diagnostic _____	7-11
Clean Exterior Surface of System _____	7-11
Clean the Liquefier Tips _____	7-11
Replace an Interior Lamp _____	7-11
Chapter 8: Troubleshooting _____	8-1
Getting Help _____	8-1
Finding a Remedy _____	8-2
Appendix A: UI Menu Structure _____	A-1
Main Menu _____	A-1

Chapter 1: Service and Support



This chapter provides the user with information on service and support for the Fortus 360mc/400mc system.

Service

If you have a problem with your 360mc/400mc that is not covered in this User Guide, please contact Stratasys Customer Support:

- Call (800) 801-6491 (7:00 a.m. to 5:00 p.m. C.T.)
- E-mail us at: support@stratasys.com

When calling in for service, always have your system's software version (see "System Software Version" on page 4-34), and hardware serial number available (see "Identifying Your System" on page 2-1). You may also need access to your Insight workstation to provide a diagnostic file from your hardware.

Software Support

If you have a software problem that is not covered in this user guide, please contact Stratasys Customer Support:

- Call (800) 801-6491 (7:00 a.m. to 5:00 p.m. C.T.)
- E-mail us at: support@stratasys.com

When calling for support, please have your system's serial number and software version available.

Safety Instructions

Hazard Types

Stratasys recommends that all services be performed by qualified personnel. All personnel working on or around this system should be knowledgeable of what the following hazard classifications mean throughout this guide.



Warning: Indicates a potentially hazardous situation which, if not avoided, may result in injury or death.



Caution: Indicates a situation which, if not avoided, could result in damage to equipment.

WARNINGS and CAUTIONS precede the paragraph to which they pertain.

Notes follow the relative paragraph.



Note: Indicates additional information relative to the current topic.

Product Safety Signs

We make every effort to ensure that our systems are safe and reliable at all times. However, there will be times when you must access areas of the system where potentially high voltages, hot temperatures, and/or moving mechanical components could cause severe injury.



Note: Always read and adhere to safety statements, and be aware of the following safety signs when you see them on the system.

Personal Injury: The personal injury sign indicates that you are near moving mechanical parts, and severe personal injury is possible. Always use extra care. Do not wear ties, loose clothing, or dangling jewelry. Keep long hair tied up and away from any moving parts.

High Voltage: The high voltage sign indicates the presence of high voltages. Always stay away from any exposed electrical circuitry. It is recommended that all jewelry be removed.

Hot Surface: The hot surface sign indicates the presence of devices with high temperatures. Always use extra care when working around heated components. Always wear the safety gloves and safety sleeves provided in the 360mc/400mc Startup Kit.

**Head temperatures in the system can exceed
350° C (662° F).**

Gloves: The gloves sign indicates that if you enter the area specified by the symbol you must wear safety gloves and sleeves approved for high temperatures provided in the Startup Kit.

Sharp Object: The sharp object sign indicates the presence of sharp objects. Do not touch sharp objects as they may cause a loss of body parts.

Crushed Hand: The crushed hand sign indicates that a hazard exists where you could get your hand crushed between two objects. One or more objects move in the area that you are working.

Specific Safety Practices

The following components and areas of the system are highlighted as potential safety hazards that may cause system failure or reliability problems if proper safety procedures are not followed.

Oven..... **Warning:** Always wear safety gloves and long sleeves when working inside the oven. Components are hot!

The oven temperature is extremely hot. The oven temperature is controlled by a safety thermal breaker that shuts the system off when temperatures reach 260° C (500° F)

Note: Opening the oven door shuts the oven heaters off.

XY Gantry..... **Warning:** Never wear a tie, loose clothing or dangling jewelry when working around moving components of the system.

Beneath the top lid of the system is the XY Gantry. This area houses the mechanical drive components of the X and Y axes. Use extreme caution whenever accessing this area of the system. The servo drive system, including the motors, pulleys and belts are extremely powerful, and care must be taken.

Note: The servo motors are disabled when the oven door or top hood is opened. The XY pinch hazard between the timing belts and pulleys is minimized by locking the hood while building and disabling the motors when the top hood is open.

Z Stage..... **Warning:** Never wear a tie, loose clothing or dangling jewelry when working around moving components of the system.

The drive belt, pulleys and Z stage servo motor can cause severe injury. The Z stage crushing hazard is minimized by locking the door during Z stage moves and disabling the Z motor when the door is open.

Head temperatures in the system can exceed 450° C (800° F).

Guard Door Interlocks

Interlock switches are used to communicate the oven door, gantry door, and top hatch states to the system. For safety reasons, the doors and hatch must be closed before the X, Y and Z motors will operate.

General Safety Practices

Abide by these general safety practices when working with this system.

High Voltage: High voltage is present in the system when powered off and unplugged due to the Uninterruptible Power supply (UPS).

 **Warning:** Only use an OSHA or CE approved step stool when accessing the area under the hood (located at the top of the system).

 **Warning:** Always wear safety gloves and long sleeves when working in the oven, with the head, or liquefier tips. these components are very hot.

 **Warning:** Always level the system prior to operation. improper leveling could cause the door to swing closed while you are working in the oven.



Chapter 2: Setup and Installation

2

This chapter describes basic setup and installation of the Fortus 360mc/400mc system.

General Information

Prepare Your Facility for Installation

Follow the 360mc/400mc Site Preparation Guide to ensure that your facility is effectively and safely prepared for system installation.

Identifying Your System

Use the following two tags to identify your system: (Figure 2-1)

- Serial Number Tag - Refer to this number when requesting service.
- Model Tag - The model number, the power requirements, and the company's address and phone number are given on the tag. All patent numbers associated with the system are listed on the lower left part of the tag.

Figure 2-1: ID Tag Location

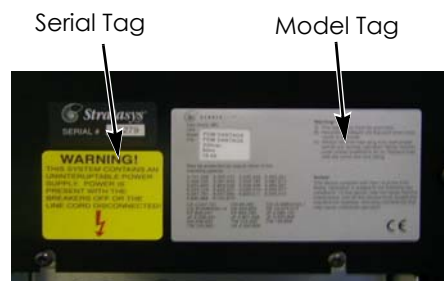

Both tags are located on the back side of the system near the bottom. They are typically placed near the system's power connection. Use the information on these tags when identifying your system.

Basic Setup

Making the Network Connection

Processed job files are transferred to the 360mc/400mc modeler through your facility's Ethernet network. An RJ45 network connector is located in the lower left corner of the back panel for the network connection. (Figure 2-2)

Figure 2-2: Network Connection

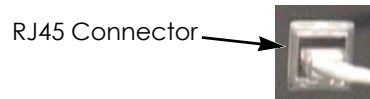

Making the External Air Connection

The external air connector is located in the lower left corner of the back panel. (Figure 2-3)

Figure 2-3: External Air Connection

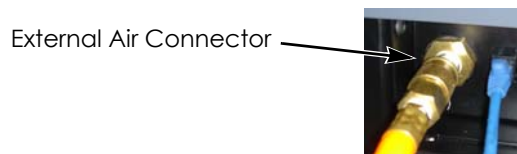

Making the Power Cable Connection



Warning: A licensed electrician must perform all wiring from service connect to the transformer, and from the transformer to the system - including all connectors, cables and proper strain relief.

This system requires a high voltage connection, which is made at the right, rear corner of the system (as viewed from the rear). High voltage is applied to the system via a Delta connection. The main breaker must be off until a Stratasys Service Technician has verified the connection. This system is only provided with a Delta connection. (Figure 2-4)

Figure 2-4: Power Cable Connection

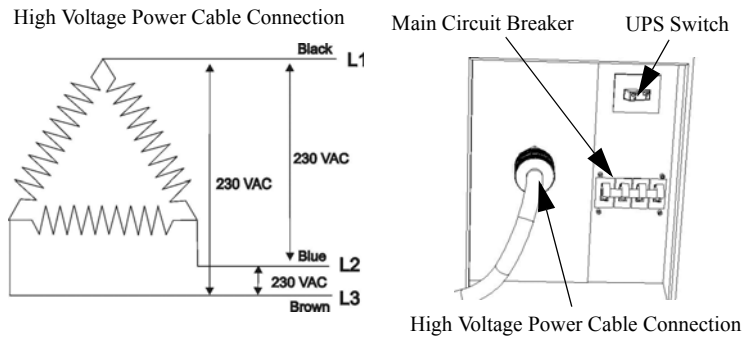

Network Setup

Your system is configured for your network as a part of its initial installation and setup. This section is provided in case you have need to change your network settings.

Configuring the Network

1. The network address can be Dynamic or Static.
 - Dynamic address - a network server or PC will generate an IP address for the system. A different IP address may be generated from time to time by the server or PC.
 - Static address - you must enter an IP address, subnet mask, and gateway address for the system (provided by the system administrator). Once entered, the address will not change.
2. In addition to configuring the IP address, you can set the UPnP configuration for the system.
 - UPnP ON - the system will broadcast its (Unique Device Name) UDN address across the network. This allows the Insight workstation software to automatically detect the IP address of the modeler for communication.
 - UPnP OFF - the system will NOT broadcast its IP address across the network. The Insight workstation software will need to be manually configured to communicate with the modeler.

Setting the IP Address

1. Power up the system, see “Powering Up the System” on page 4-3.
2. From the Ready screen, select **Maintenance** and press ENTER.

```
Build Job..          | *Tips: Model T16
Operator Control..  | *   Support T16
Modeler Status..
>Maintenance..
```

3. Select **Administration** and press ENTER.

```
Modeler Default..
>Administration..
Reboot system..
```

4. Select **Network Configuration** and press ENTER.

```
>Network Configuration..
Receive Software Upgrade or Code..<E>
Field Service.. password:
```

5. Choose **YES** or **NO** for the **Dynamic IP**

```
Dynamic IP: YES <E>
UpnP: ON <E>
*Configure Static Network Address
```

```
Dynamic IP: NO <E>
UpnP: ON <E>
>Configure Static Network Address
```

6. If the **Dynamic IP** is set to **NO**, select **Configure Static Network Address**, then:
 - Select **IP** and enter the address using the keypad. Press ENTER. You can use the DEL key to erase incorrect entries.
 - Select **MASK** (Netmask) and enter the address. Press ENTER.
 - Select **GW** (Gateway) and enter the address. Press ENTER.

```
>IP : [172.16.70.10]
MASK: (.none found)
GW : [172.16.100.1]
```



Note: See your system administrator if you do not know the IP, Netmask, or Gateway address.

7. Choose **YES** or **NO** for the **UPnP**

Moving the System

If you need to move the system to a different location, a specific sequence of steps must be followed.

1. Unload material filament from the liquefiers. See “[Unloading Material from the Liquefier Tips](#)” on page 4-13.
2. Remove the material canisters. See “[Removing Canisters](#)” on page 4-14.
3. Lower the Z stage to the bottom of its travel. See “[Moving the Z Stage to Bottom of Travel.](#)” on page 4-36.
4. Shut down power to the system. See “[Powering Down the System](#)” on page 4-4.



Warning: Due to the UPS, High voltage is present in the system with the power cord unplugged.



Caution: Before unplugging the system always make sure the oven is cool to avoid blowing the oven thermal cut-out fuses.

5. Unplug the power cable from the power source.
6. Secure the Z stage:
 - A. Remove all side panels on the system.
 - B. Grasp the Z stage drive belt and the lower Z stage until the end plates rest on the lower hard stops.
 - C. On the left and right side of the system, wrap a large wire tie around the end plate and the lower bearing mount plate, see [Figure 2-5](#).
 - Make sure the wire tie is tight.

Figure 2-5: Securing the Z Stage

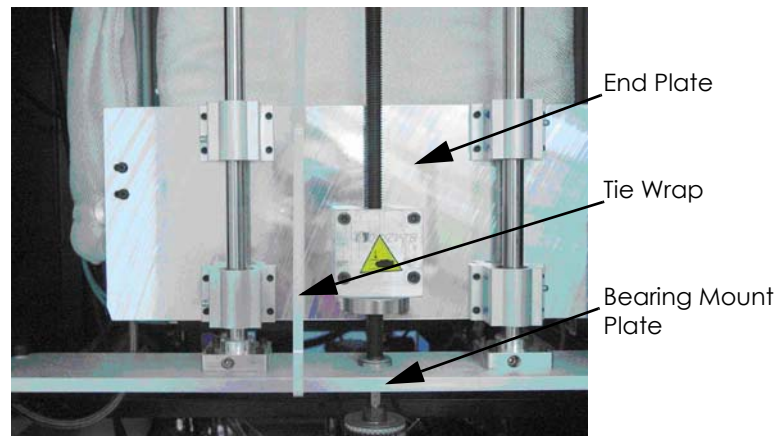

7. Secure the XY Gantry: (Figure 2-6)



Warning: Use an approved safety ladder to access the hood.

- A. Open the hood door and hood lid.
- B. Manually position the gantry in the left front corner of the XY table.



Caution: Do not use the head service handle to secure the XY Gantry. Damage to the head could occur.

- C. Using several wire ties, secure the head to the frame.

Figure 2-6: Securing the XY Gantry

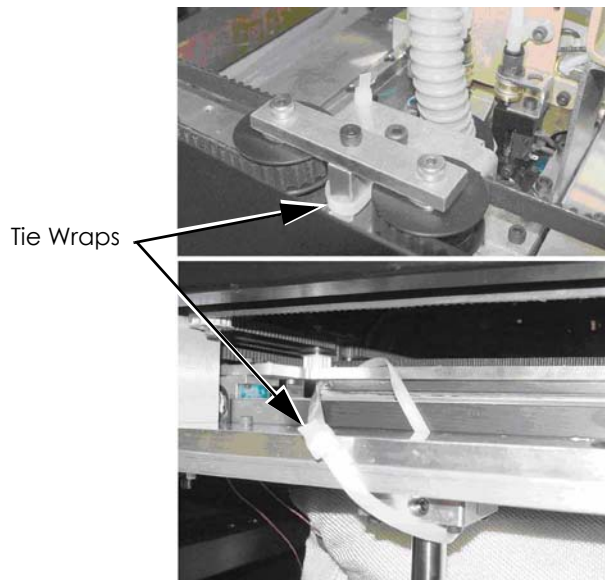

- 8. Reinstall and secure all panels.
- 9. Raise the support feet located near each caster by loosening the locknut on each foot (Figure 2-7).

Figure 2-7: System Casters

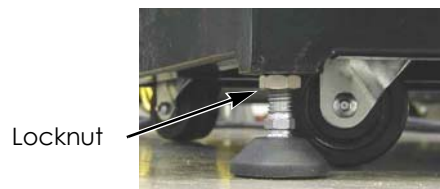

Caution: If the system will be rolled over floor seams or bumps, do not roll the system on the casters. Use an appropriate lifting device.



Caution: If a forklift is used to lift the system, use it in accordance with the specifications in the site prep guide.

10. Move system to its new location.



Caution: If the system will be rolled over floor seams or bumps, do not roll the system on the casters. use an appropriate lifting device.

11. Lower the support feet and lock them in place using the locknut.
12. Cut the wire ties securing the Z stage end plates to the bearing mount plates.
13. Cut the wire ties securing the XY gantry to the frame.
14. Plug the power cable into the available power source.



Chapter 3: System Components

3

This chapter describes the system components of the Fortus 360mc/400mc system. Information on model materials and tips that can be used by the system are also included in this chapter.

System Protection

Main Circuit Breaker

If the system encounters a high current surge, the main circuit breaker trips, protecting the system's electrical and electronic components. The circuit breaker is located at the right, rear corner of the system (as viewed from the rear). To return the system to operation, reset the circuit breaker. This is accomplished by pushing the circuit breaker handle all the way down and then back up.

Thermal Cut-Out Fuses

There are two thermal cut-outs installed on the system. When a cut-out reaches its set temperature, it opens, and power to the system is removed. This prevents damage to the system if an overheat condition occurs. Contact Customer Support if a thermal cut-out opens.

UPS



Warning: Due to the UPS, High voltage is present in the system when the power cord is unplugged.

The UPS (Uninterruptible Power Supply) unit is a battery standby system that supplies AC voltage to the processor and cooling fans in the event of an AC voltage power loss. It does not run the entire system.

In the event of an overcurrent condition, the UPS is protected by a combination power switch and circuit breaker that is located directly above the main breaker. (Figure 3-1)

Figure 3-1: UPS Power switch location

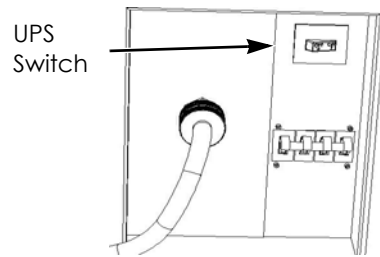

If power is lost to the modeler

- The UPS allows the modeler to complete its cool-down cycle and then shuts itself off.
- If power is restored to the modeler during the shut-down process, the shut-down will continue. The modeler can be re-started when shut-down is complete (push the green button on the front panel).

During normal system power-down

- The UPS allows the modeler to complete its cool-down cycle and then shuts itself off.
- The modeler can be re-started when shut-down is complete (push the green button on the front panel).

Access Doors and Panels



Warning: The rear access panels should only be removed by a Stratasys service technician.

This system has been designed to allow easy access to the most frequently accessed areas on the system. Doors and Panels that you may need to open or remove are highlighted in [Figure 3-2](#) & [Figure 3-3](#).

Figure 3-2: System Doors and Panels

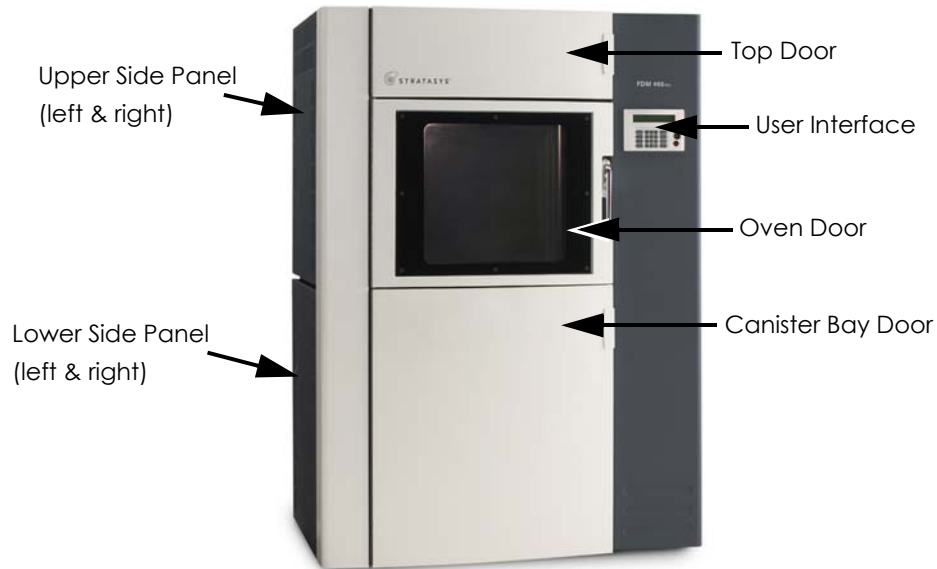
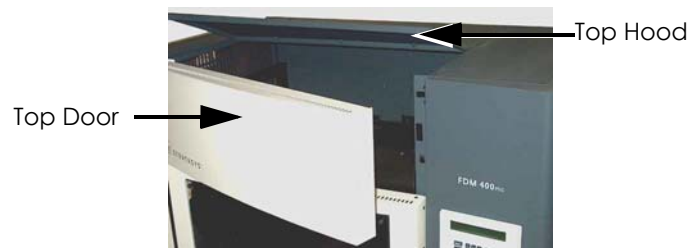

Figure 3-3: Top Door and Top Hood



Top Door and Top Hood

Allows access to the XY Gantry, head assembly, and four cooling fans. The cooling fans cool the upper area of the XY Gantry and head area. The two fans on the left draw cool air into the system. The two fans on the right draw warm air out of the system.

Oven Door

Allows access to the platen, tip wipe assembly, and modeled parts.

Canister Bay Doors

Allows access to the material canisters, purge waste bucket, storage area, vacuum gauge, pressure gauge, canister levers, and canister LEDs.



Warning: Turn power Off and disconnect the power cable before removing any of the access panels.



Warning: High voltage is present in the system when the system is Off and the power cord is unplugged. This is due to the Uninterruptible Power Supply (UPS). Make sure you follow the correct shutdown procedure. See [“Powering Down the System” on page 4-4.](#)

Right Side Door - Upper

Allows access to the right side Z stage components. To remove the panel, loosen the four panel retaining screws (the screws do not have to be removed).

Right Side Door - Lower

Allows access to some of the electronic bay components such as the computer case, CD-ROM, in-line vacuum filter, keyboard, monitor connectors, and the vacuum system. To remove the panel, loosen the four panel retaining screws (the screws do not have to be removed).

Left Side Door - Upper

Allows access to the left side Z stage components. To remove the panel, loosen the four panel retaining screws (the screws do not have to be removed).

Left Side Door - Lower

Allows access to the air compressor, material drying system, flow meter, and some electronics bay components. To remove the panel, loosen the four panel retaining screws (the screws do not have to be removed).

Gantry Area (XY Table)

Opening the Top Door and Top Hood

1. To access the XY Gantry or the Head, open the top door and top hood. The door and hood share a safety switch and a continuous solenoid. The top door remains locked during system operation and can only be unlocked by performing an Open Hood/Door command, which allows you to manually open the doors. (The Open Hood/Door command also unlocks the oven door allowing you to manually open it.)



Note: The top hood cannot be opened until the top door is opened. Close the top hood before closing the top door.

2. The system cannot resume operation, if the top door or top hood is open. Additionally, a manual move command cannot be sent to the system until both the door and hood are closed (the screen will flash Hood/Door not closed).

XY Gantry Assembly

1. The Gantry maneuvers the head in the X and Y directions when building a part. The XY Gantry assembly is located under the top hood of the system. The entire gantry is outside of the oven. Only the bottom of the head protrudes into the oven. The gantry and its drive motors are thermally shielded from the oven via bellows.
2. To move the head, the XY gantry utilizes one X and one Y servo motor attached to timing belts. (Figure 3-4)

Figure 3-4: XY Gantry Assembly

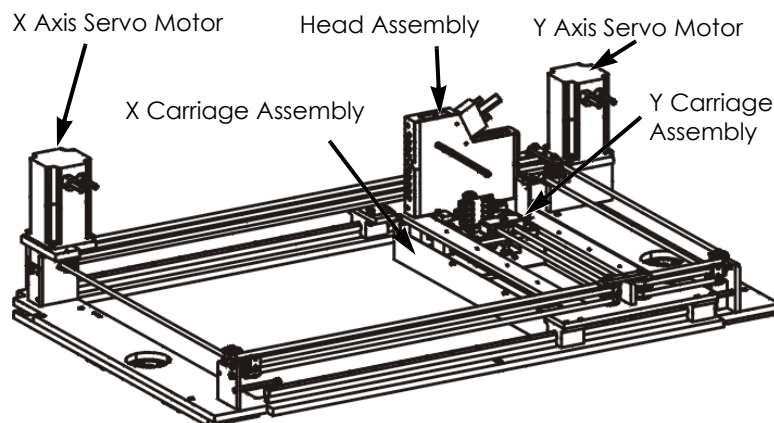

Head Assembly

1. The head assembly has been designed for use with a wide range of modeling materials. The board inside the head provides direct heater and thermocouple control. The head extrudes modeling material and support material with two identical liquefiers. The support liquefier moves up and down via a drive motor.
2. The liquefier tips are clamped directly between the heated block and liquefier clamp block with two screws. (Figure 3-5)

 **Note:** You must replace each liquefier tip when you load a different type of material.

Figure 3-5: Head Assembly



Head Maintenance Bracket

The 360mc/400mc is equipped with a Head Maintenance Bracket which places the head in a convenient location for many head maintenance tasks. To place the head in the bracket: (Figure 3-5 & Figure 3-6).

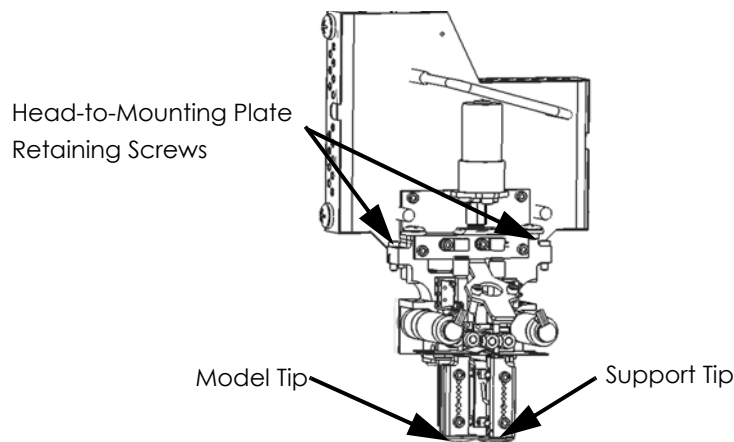
1. Place system in Pause or Idle state.
2. Move the head to the Service Location (**Operator Control > Move Head/ Stage > Move Head To Service Location**)
3. Open the Top Door and Hood (**Operator Control > Unlock Door**).
4. Loosen the two head mounting plate retaining screws.

 **Note:** The retaining screws are 'captured'. They should not be unscrewed from the head.

5. Place the head into the head maintenance bracket and secure the head with the head mounting plate retaining screws.

i **Note:** When the head is in the maintenance bracket, clean out the head tray. (Figure 3-7)

Figure 3-6: Location of Head Maintenance Bracket

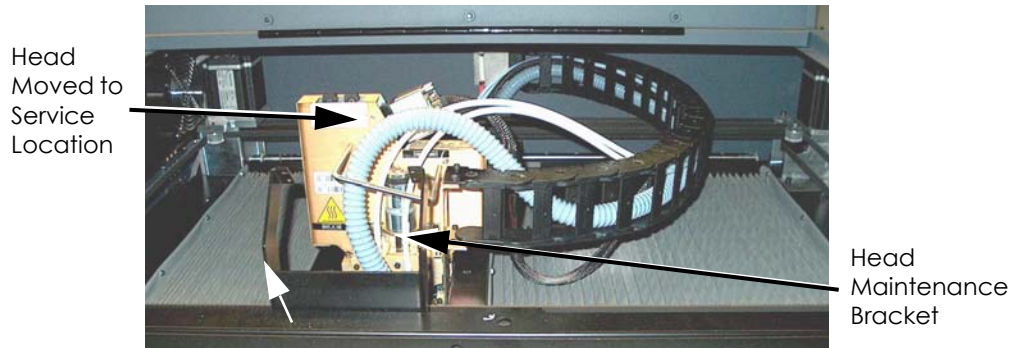
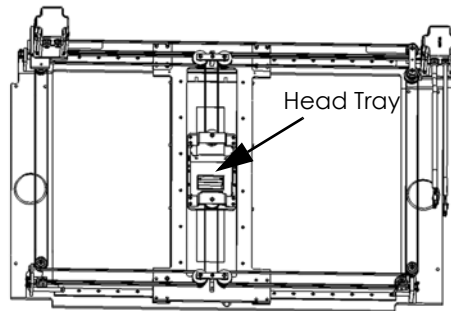

Figure 3-7: Head Tray



Modeling Materials and Tips

Materials

Materials Used

The 400mc system can use high strength polycarbonate material (PC); ABS-M30 or ABS-M30i used with SR-20 or SR-30 water soluble supports; ABS-ESD7 used with SR-30 water soluble support, translucent ABSi, UV resistant ASA used with SR-30 water soluble support, Ultem* 9085, which is certified for use on commercial aircraft, Polyphenylsulfone (PPSF), which has the highest heat and chemical resistance, and Nylon 12, which is the first semi-crystalline Fused Deposition Modeling (FDM) thermoplastic. SR-30 is ductile and dissolves up to three times faster than SR-20. [Table 3-1](#) shows the material build temperatures. The 360mc system uses ABS-M30, PC-ABS, and PC material.

Materials Compatibility

System/Material compatibility can be found in [“Tip Compatibility & Selection” on page 3-9](#). Materials available depend on options purchased with the system. See [Available Options](#) for material options available to the 360mc and 400mc systems.

Table 3-1: Material Build Temperatures

Material	Maximum Extrusion Temp.	Maximum Oven Temp.
ABSi	330° C (626° F)	85° C (185° F)
ABS-M30 ABS-M30i	320° C (609° F)	95° C (203° F)
ABS-ESD7	320° C (609° F)	95° C (203° F)
ASA	330° C (626° F)	100° C (212° F)
Nylon 12	355° C (671° F)	120° C (248° F)
PC-ABS	330° C (626° F)	110° C (230° F)
PC PC-ISO	365° C (689° F)	145° C (293° F)
Ultem* 9085	400° C (752° F)	190° C (374° F)
PPSF	415° C (779° F)	225° C (437° F)

Note: All materials use the same canister type. Extrusion and oven temperatures are automatically set by the modeler.

Liquefier Tips

Liquefier Tips and Slice Heights

Two types of liquefier tips are available. Standard tip tips are used for all modeling materials and for Break-Away Supports (BASS) materials and soluble tips are used for soluble support materials. When modeling with materials that use soluble release support material (SR), use the T12SR20, T12SR30, or T12SR100 tip for the support material.

- There are seven tips available: T10, T12, T12SR20, T12SR30, T12SR100, T16, and T20.
- Tips are a replaceable consumable item. To change tips, see [“Changing Tips or Material Type” on page 4-22](#).
- Tips must be changed when the material type is changed.

Tip Compatibility & Selection

[Table 3-2](#) shows the available material and tips.

[Table 3-3](#) lists the slice heights for the three model tips.

[Table 3-4](#) provides approximate Tip Life - based upon the amount of material used.

- The system tracks tip use and automatically prompts you, through the user interface, when a tip should be replaced. Worn tips are prone to clogs and reduce part quality. See [“Odometer Status” on page 4-32](#) for more information on viewing tip use status.
- When changing tips, the system will guide you through resetting the tip odometers from the display panel.
 - If building with ABS-M30/M30i, you can use either SR-20 or SR-30 support material.
 - If building with ABS-ESD7, you can use SR-30.
 - If using SR-20 material, use T12SR20 tip only (previously called a T12SR tip).
 - If using SR-30 material, use T12SR30 tip only.
 - If using SR-100 material, use T12SR100 tip only.
 - If using SR-110 material, use T12SR100 tip only.

The standard tip is used for Break-Away Supports (BASS) and model material. See [“Tip Identification” on page 3-12](#) for more information.

Table 3-2: Available Tips

Model Material	Model Tip	Support Material	Support Tip
ABSi	T10, T12, T16, T20	SR-20	T12SR20
ABS-M30 ABS-M30i	T10, T12, T16, T20	SR-20 SR-30	T12SR20 T12SR30
ABS-ESD7	T12, T16	SR-30	T12SR30
ASA	T10, T12, T16, T20	SR-30	T12SR30
Nylon 12	T12, T16, T20	SR-110	T12SR100
PC-ABS	T10, T12, T16, T20	SR-20	T12SR20
PC	T10, T12, T16	SR-100	T12SR100
PC PC-ISO	T12	PC_S	T12
PC/PC-ISO	T16, T20	PC_S	T16
Ultem* 9085	T16	ULT_S	T16
PPSF	T16, T20	PPSF_S	T16

Table 3-3: Slice Height

Model Tip	Slice Height
T10	0.005 in. (0.127 mm)
T12	0.007 in. (0.178 mm)
T16	0.010 in. (0.254 mm)
T20	0.013 in. (0.330 mm)

Table 3-4: Tip Life

Model^a Material	Model Tip	Model Tip Life^b			Support Tip	Support Tip Life^b		
		cu. in.	cu. cm.	Canisters		cu. in.	cu. cm.	Canisters
ABSi	T10	620	10160	6.5	T12SR20	270	4420	3.0
ABSi	T12	770	12620	8.5	T12SR20	550	9010	6.0
ABSi	T16	920	15080	10.0	T12SR20	640	10550	7.0
ABSi	T20	920	15080	10.0	T12SR20	640	10550	7.0
ABS-M30 ABS-M30i	T10	620	10160	6.5	T12SR20 T12SR30	270	4420	3.0
ABS-M30 ABS-M30i	T12	770	12620	8.5	T12SR20 T12SR30	550	9010	6.0
ABS-M30 ABS-M30i	T16	920	15080	10.0	T12SR20 T12SR30	640	10550	7.0
ABS-M30 ABS-M30i	T20	920	15080	10.0	T12SR20 T12SR30	640	10550	7.0

Model ^a Material	Model Tip	Model Tip Life ^b			Support Tip	Support Tip Life ^b		
		cu. in.	cu. cm.	Canisters		cu. in.	cu. cm.	Canisters
ABS-ESD7	T12	770	12620	8.5	T12SR30	550	9010	6.0
ABS-ESD7	T16	920	15080	10.0	T12SR30	640	10550	7.0
ASA	T10	620	10160	6.5	T12SR30	270	4420	3.0
ASA	T12	770	12620	8.5	T12SR30	550	9010	6.0
ASA	T16	920	15080	10.0	T12SR30	640	10550	7.0
ASA	T20	920	15080	10.0	T12SR30	640	10550	7.0
Nylon 12	T12	491	8050	5.3	T12SR100	550	9010	6.0
Nylon 12	T16	552	9010	6.0	T12SR100	664	10880	7.1
Nylon 12	T20	552	9010	6.0	T12SR100	664	10880	7.1
PC	T10	620	10160	6.67	T12SR100	270	4420	3.0
PC	T12	740	12060	8.0	T12 T12SR100	370 550	6030 9010	4.0 6.0
PC	T16	830	13570	9.0	T16 T12SR100	460 644	7540 10553	5.0 7.0
PC	T20	830	13570	9.0	T16	460	7540	5.0
PC-ISO	T12	740	12060	8.0	T12	370	6030	4.0
PC-ISO	T16	830	13570	9.0	T16	460	7540	5.0
PC-ISO	T20	830	13570	9.0	T16	460	7540	5.0
PC-ABS	T10	270	4420	9.0	T12SR20	270	4420	9.0
PC-ABS	T12	550	9010	6.0	T12SR20	550	9010	6.0
PC-ABS	T16	828	13570	9.0	T12SR20	664	10550	7.0
PC-ABS	T20	828	13870	9.0	T12SR20	644	10550	7.0
Ultem* 9085	T16	550	9010	6.0	T16	460	7540	5.0
PPSF	T16	180	3010	2.0	T16	180	3010	2.0
PPSF	T20	180	3010	2.0	T16	180	3010	2.0
Continued on next page								

a. ABS-M30/M30i model materials can use SR-20 or SR-30 support materials. Use the T12SR20 tip for SR-20 material (regardless of model tip size) and use the T12SR30 tip for SR-30 material (regardless of model tip size). PC-ABS and ABSi model material requires the use of SR-20 support material & the T12SR20 support tip (regardless of model tip size). ASA model material uses SR-30 support material. A T12SR30 support tip should be used regardless of model material tip size. PC model material uses PC_S support material. Support tip matches model tip size for T16 and T12. PC T20 uses a T16 support tip. Ultem* 9085 model material uses ULT_S support material. PPSF model material uses PPSF_S support material. Support tip size matches model tip size. Nylon 12 model material uses SR-110 support material. A T12SR100 support tip should be used regardless of model material tip size.

b. Tip Life is directly related to the amount of material that passes through the tip. The amounts listed above are approximates of how much material will pass through a tip before the tip will need to be replaced. Because other factors can affect tip life, the material amounts are only approximates.

Tip Identification

Figure 3-8: Tip Identification

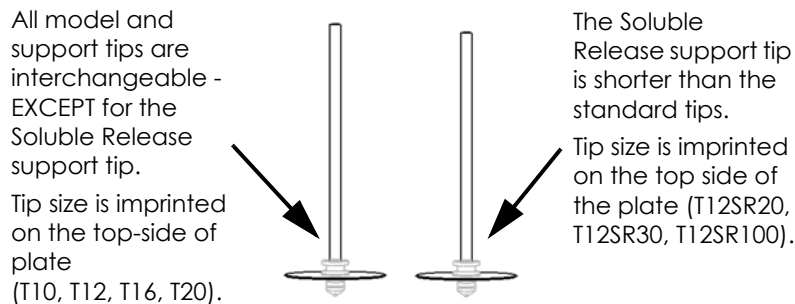

Oven Bay

Oven Door

The Oven Assembly (also called the Oven Bay) includes the oven door and everything that you see through the front door glass. The bay is where parts are built. The oven door uses a continuous solenoid. The Unlock Hood/Door command will release the solenoid allowing you to open the door.

1. From the Main Menu select **Operator Control** and press ENTER

```
Build Job.. | *Tips: Model T16
>Operator Control.. | * Support T16
Modeler Status..
Maintenance..
```

2. Select **unlock Door** and press ENTER

 **Note:** This command is only available while the system is paused or in an idle state. You do not have access to this command while the gantry is moving.

```
>Unlock Door <E> | Calibrate..
Load/Unload Matl.. | Temp Control..
Change Tips/Matl.. | Move Head/Stage..
```

3. If the temperature is high, a warning screen may appear. Press ENTER again to unlock the door.

 **Note:** Once any door is unlocked and/or opened, system operation cannot be resumed. Additionally, a manual move command cannot be sent until all doors are closed. When all doors are closed, the solenoids reactivate and you can resume operation.

Oven Components



Gloves: Oven lights are hot! Do not touch without wearing approved safety gloves.

Oven Lamps

There are two incandescent oven lamps mounted in the two front upper corners of the oven. The lamps are rated at 240 volts and 40 watts. There is a lamp (light) switch on the keypad, which you can use to manually turn the light ON or OFF. (Figure 3-9)

Figure 3-9: Oven Lamp



The Platen

The platen is the surface on which parts are built. A plastic build sheet is held to the 17" x 15" aluminum platen by the vacuum source. The platen has a waffle pattern machined into the top surface. This allows vacuum to pull across the entire surface. A silicone rubber o-ring, that runs around the perimeter of the platen, helps seal the build sheet to the platen.

A debris screen (not a customer removal part) is placed across the vacuum port, located at the center of the platen, to prevent material particles from entering the vacuum lines.

The platen is mounted to the Z stage cross beams with three adjustment screws. This allows the platen to be leveled. The tip sensor is used when performing a Auto tip-to-tip calibration.

Figure 3-10: Platen Components

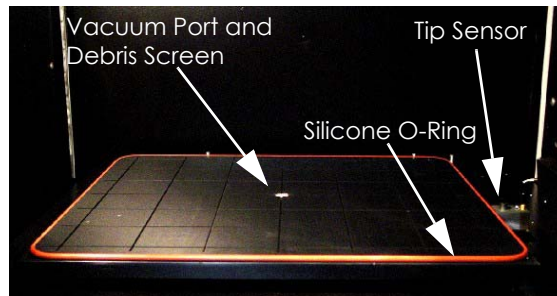

Tip Cleaning Assembly

The Tip Cleaning Assembly is located to the front, right side of the oven. The assembly consists of two flicker/brush assemblies (1 for each tip) and a debris chute. The flicker/brush assemblies keep the liquefier tips free of debris and material buildup. The debris chute directs debris into the material waste basket (purge bucket) located in the canister bay compartment.

Figure 3-11: Tip Cleaning Assembly



Z Stage

The Z stage assembly moves the platen up or down. This is accomplished with two belt driven lead screws - accessed by removing the upper right and upper left panels (see [“Access Doors and Panels”](#) on page 3-2). The majority of the left and right Z stage assemblies are mounted outside of the oven to keep them away from heat. (Figure 3-12)

Figure 3-12: Z Stage and Oven Components

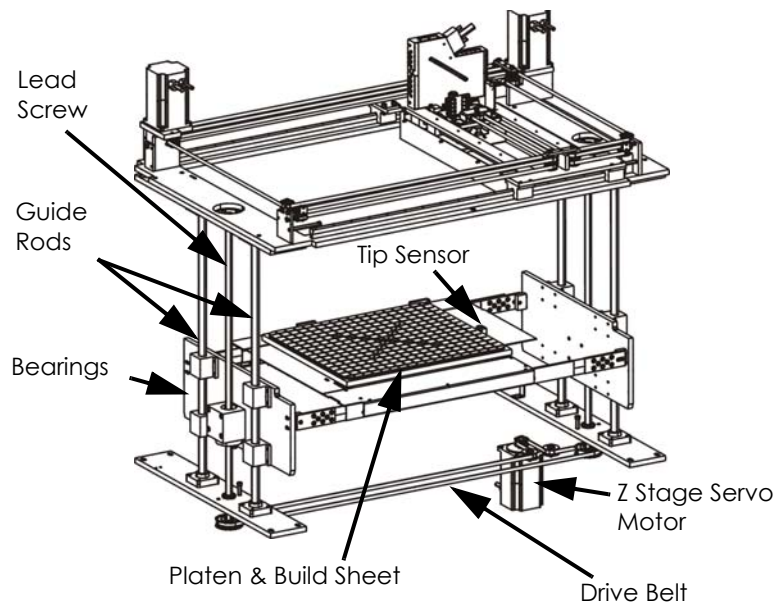

- **The platen and build sheet** - provide the build surface. Replace the build sheet every time you build a new part.
- **The tip sensor** - located on the right side of the platen. It is used to calibrate the model and support tip in the Z axis when tips are changed.

- **Lead Screws, Guide Rods, & Bearings** - located on both sides of the oven. They provide the structure for moving the platen up and down.
- **Z Stage Servo Motor** - mounted beneath the oven. It provides the power to move the platen up and down.
- **Drive Belt** - located beneath the oven and synchronizes the platen movement on both sides of the oven.

Canister Bay

Accessing the Bays

The canister bays are accessed by opening the canister bay door on the front of the system (Figure 3-13). The canister bay door is not a part of the door safety interlock system and, therefore, can be opened during system operation.

**Figure 3-13: Canister Bay Components
(Shown with 4 operable bays - Large Oven Option)**

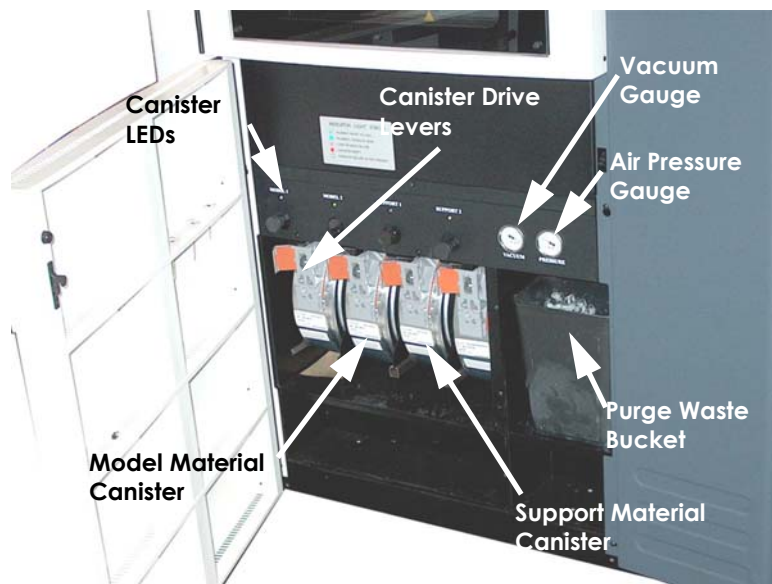

Canister Bay Components

1. The Canister Bay
 - A. The standard 360mc/400mc system has two operating material bays - 1 model and 1 support.
 - An optional four bay upgrade (large oven option) is available for the system and can be added before or after system installation.
 - B. For 2 bay systems, the middle two bays are operating bays.

- The middle left bay holds modeling material; the middle right bay holds support material.
- The two end bays can be used for canister storage.

C. For four bay systems, all 4 bays are also operating bays.



Note: Auto Changeover capability is included with the 4-bay option - automatically loading a second canister during a build when the first canister runs out of material (see “Canister Auto Change-over” on page 4-20).

- The left two bays holds modeling material; the right two bays holds support material.

D. While building, two canisters will be active. An active canister has material filament loaded to the liquefiers (steady green LED).

- On four bay systems, you can replace inactive canisters without pausing the system.

2. Canister Drive Block and Drive Lever

A. Each individual canister bay has a material drive block and a drive lever. (Figure 3-14)

B. The drive block feeds the filament from the canisters to the liquefiers.

- The drive block is located above the canister and contains a small DC motor which drives the filament up to the liquefiers.
- The drive block is spring loaded and moves up and down on guide pins. The spring provides positive pressure for the drive block against the top of the material canister.
- The drive block contains a material sensor. The sensor is used to communicate to the system when material is available to be loaded to the liquefiers.

C. The drive lever is used to engage (and disengage) the drive block with the canister.

Figure 3-14: Drive Block Lever

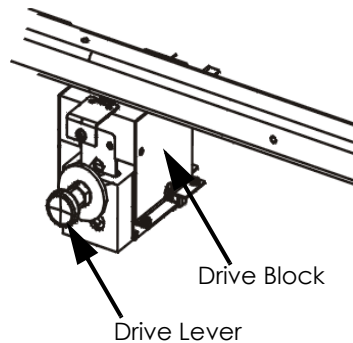

3. LED Indicators

There is one colored LED light above each canister. The LED indicates the canister condition for each bay (Figure 3-13):

- Green - Steady. Material filament has been loaded into the liquefiers. You cannot remove the canister when the LED is a steady green.
- Green - Flashing (Ready state). Filament has been fed into the canister drive block but is not loaded into the liquefiers. You can unload canisters if necessary.
- Red - Steady. The canister is empty. You can unload the canister if necessary.
- Red - Flashing. The canister has a load failure or a smart-spool-chip read/write failure. You can unload canisters if necessary.
- Off. No canister is present, or the canister is present but the filament has not been fed into the canister drive block.

SmartSpool System

1. The 360mc/400mc uses the SmartSpool system to give you canister information. This allows you to manage material resources, and maximize part build strategies for long, unattended part builds.
2. Each canister contains an encoded chip (Figure 3-15) that tracks the status of the canister material. Canister information is reported to the system and displayed on the user panel.
 - A. The system user display provides basic canister information.
 - Type of material.
 - Estimated amount of material remaining.
 - B. The system user display prompts you if one of the material canisters is not in a 'ready state' (flashing green LED).

- C. When you choose to build a CMB file (see [“Sending a Part to the Modeler” on page 5-7](#)), the system compares stored information within the CMB file to the canister information.
- a. The CMB file material type is compared to the system canister material type. If the materials do not match, the user display prompts you to change the system materials to the appropriate type.
 - You can choose to ‘Continue’ the build with the mis-matched material type, but part build quality will be unpredictable.
 - b. The CMB file contains an estimate of the material amounts (model and support) required for the part build. The estimate is compared to the amount of material in each canister. If there is not enough material available to finish the part, you are given an option to change canisters before initiating the build.
- c. Examples of canister related prompts:



Note: A specific prompt will only be displayed if that issue is detected.



Note: Select the prompt to perform the action (see [“Build Job Warnings” on page 4-7](#)).

- [Need Both \(or '4'*\) Canisters Present..](#)
(* on 4-bay system)
- [Change Model Canister to PC](#)
- [Need More Model Mat'l \(0009.4 more\)](#)
- [Change Support Canister to PC_S](#)
- [Need More Support Mat'l \(0013.2 more\)](#)
- [Continue...](#)

Figure 3-15: SmartSpool Canister

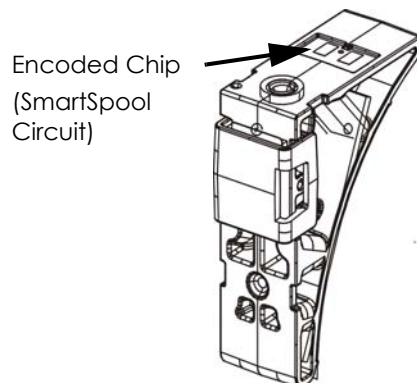

Vacuum and Air Dryer Systems

On Board Vacuum System

1. The vacuum pump generates the vacuum used to hold the build sheet to the platen. The amount of vacuum generated by the pump can be read on the vacuum gauge located above the purge waste bucket.
2. The vacuum system also contains an in-line vacuum filter (to remove debris from the vacuum system - see [“Clean the Vacuum System In-Line Filter and Jar” on page 7-8](#)) - and a vacuum switch (which prevents the system from operating if vacuum is not present).
 - For external air, vacuum is provided by an internal vacuum generator.

On Board Air Dryer System

1. The material drying system ([Figure 3-16](#)) is designed to help keep loaded material filament dry. An air compressor is used to force dry air through the filament tubes. The compressed air is pushed through a regenerating dryer where the air is dried to -40° F dew point. The dried air is diverted between two dryer elements every 30 seconds.
2. The pressure and flow of the dried, compressed air is controlled by a pressure regulator and a separate air flow meter. A pressure gauge in the canister bay displays air dryer system pressure - we recommend a setting of 36-40 psi. Captured moisture and debris are exhausted out the bottom of the system.
 - For external air, pressure is provided by an external air source.

Figure 3-16: Material Drying System (On Board Air Only)

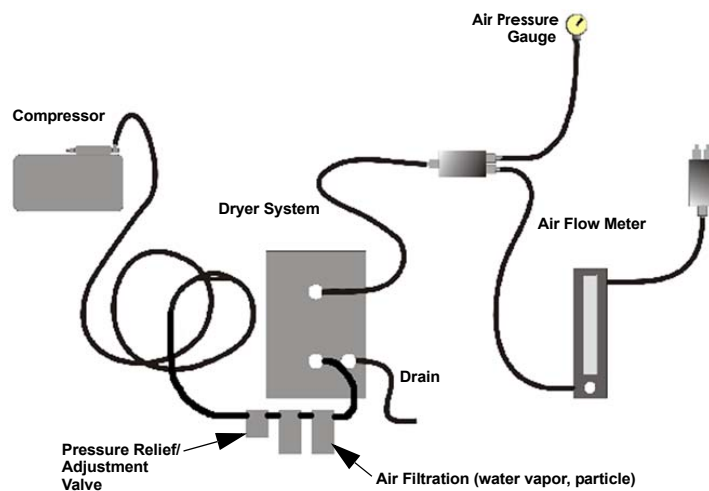

Chapter 4: Operating the System

4

This chapter explains basic steps in operating the Fortus 360mc/400mc system.

Basic User Interface and Operations

The Operator Control Panel consists of a four-line by 40 character display with keypad. The panel is located on the front right face of the system. The Operator Control Panel is easy to use. All user interface is menu driven.

Figure 4-1: Operator Panel



The operator control panel (Figure 4-1) allows you to:

- Access material loading and unloading functions along with access to calibration.
- Open the oven door, top door, and hood.
- Monitor system status.
- Monitor material status (type loaded and amount).
- Monitor job status (number of hours completed, number of hours total, current build height and total build height, and the name of job currently being built).
- Turn system power ON or OFF.
- Access network configuration.
- Access the job queue.
- Access the sample job queue.

Using the Keypad

The Operator Control Panel has the following keypad buttons (Figure 4-2):

Figure 4-2: Keypad Buttons

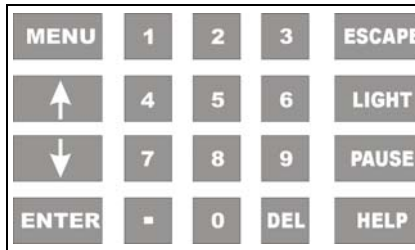

Button	Description
MENU	Takes you up one level in the menu directory, unless stated otherwise. It is also used to take you out of the Help system.
Up Arrow	Moves the cursor up one line in the display each time it is pressed.
Down Arrow	Moves the cursor down one line in the display each time it is pressed.
ENTER	Activates the selection indicated on the display.
ESCAPE	Takes you back to the Main Menu, unless stated otherwise.
LIGHT	Toggles the Oven Light ON and OFF.
PAUSE	Pauses the current build job. To Pause, hold button in for 2-3 seconds. Use the Resume Build command to resume build.
HELP	Displays Help information for the current menu.
Dot <.>	Shows details of the current job selected in the queue. Available only when job queue is being viewed. (When in detail view, use arrow keys to display other jobs in queue.) Toggles between all sample jobs and only jobs for the current system configuration.
DEL	Deletes entered characters, jobs in the job queue, and jobs in the sample queue.
1 - 9	In addition to entering the numbers 1 through 9, the number keys perform the following actions:
1	Moves a job to the top of the queue. Available only when job queue is being viewed.
2, 4, 6, 8	Move the axes: <4> (X left), <6> (X right) <2> (Y back), <8> (Y front).
3, 9	Move the Z stage: <3> (Z up), <9> (Z down).
9	Copies the selected job to the sample queue. Available only when job queue is being viewed.

Screen Symbols

The following symbols are used in the menu displays.

Symbol	Description
<E>	Push ENTER to execute the command line. (The cursor ">" must be on the same line.)
<E>..	Push ENTER to execute command line. Also pushes you into another menu.
".."	Tells you that this line is a menu change. It implies that you may return without executing a command.
":"	Indicates that this command line value changes.
" = "	Value displayed in the command line is user changeable.
" * "	Indicates that this is a comment line. (Symbol is shown at beginning of line.)
(!)	Displayed at the end of a line in the job queue or sample queue. Indicates insufficient material available; wrong type of material loaded; or wrong tip installed. Select line and press <.> (Dot key) to show details.
"!!"	Displayed at start of Warning message.
C	Temperatures are displayed in Celsius only.

Powering Up the System

1. Turn the system ON by pressing the flashing green button (Figure 4-1).
 - The Power up message is displayed.
2. If there is a completed part in the system, select Unlock Door <E>, and remove the part from the system. Install a new build sheet and close the door.
3. Verify that the air pressure gauge (located in the canister bay) reads 36-40 psi. (External air should be 48-52 psi.)
4. Select **AutoHome XYZ** and press ENTER.
 - The system will find the home position for the X, Y, and Z axes. This must be done before any parts can be built.
5. If the system has been powered down long enough for the oven to cool, allow the oven to heat and stabilize for at least four hours before performing system calibrations or part build.

Powering Down the System



Warning: Due to the UPS, High voltage is present in the system when the power cord is unplugged.



Caution: Do not turn the blowers off prior to the five minute time-out or damage to the system may occur.

To power down the system, press the red button (Figure 4-1).

- The oven lights go off.
- After a couple minutes, a series of shutdown messages flash on the screen.
- The screen will show: **It is now safe to turn off your system.**
- After a few minutes, the green light on the panel starts to flash.



Note: If you unplug the system, the head and oven blowers on the system will continue to operate off the UPS for approximately five minutes. The only way to turn the blowers off is to turn the UPS off.



Note: Always wait a minimum of five minutes before powering the system ON again.

Basic Job Build Tasks

Before a Job Build

To build a job, you must send the job file to the modeler from the Insight application installed on your workstation. Jobs are sent in a CMB format and placed in the job queue (stored on the system hard drive). The header of the CMB file contains the processed job's basic information (material type, approximate material amount required for build, tip size, etc.). This information is used to verify job compatibility with the system setup.

For information about how to use Insight, see [“Operating Insight” on page 5-1](#).

For detail about how the system uses file information see [“SmartSpool System” on page 3-18](#).

1. Prepare the system:
 - A. Power up the system.
 - B. Install a new build sheet.



Warning: Wear proper safety equipment when handling items inside the oven. Surfaces in the build chamber can be very hot.

- c. Remove the plastic wrap from both sides of a new build sheet.



Note: Always use a new build sheet when building a job. The build sheet is intended for one-time use. Do not turn a build sheet over and place it on the platen. Material residue on the sheet can adhere to the platen or interfere with the build sheet vacuum.



Note: Using build sheets not provided by Stratasys may impact part quality and system reliability.



Note: ABS, ASA and PC parts use a clear build sheet.
PPSF and Ultem* 9085 parts use an amber-colored build sheet.
Nylon 12 parts use a green tinted build sheet.

- b. Set the build sheet on the platen.
 - Make sure the sheet overlaps the rubber o-ring equally on all sides and the sheet is against the back stops.
 - If the oven is hot, the build sheet will curl when placed on the platen. As the build sheet warms up, it will flatten and adhere to the platen. Some adjustment of the sheet may be necessary to seal it against the platen.
- c. Check the vacuum gauge (located in the canister bay).
 - Vacuum should read -15 Hg or higher (more negative) before building a part.
 - The system should attain this level of vacuum within about five minutes.
- C. If new tips have been installed, run “Auto Z Stage Zero Calibration” on page 6-1 and an “Auto Tip-to-Tip Calibration (AutoCal Tip Offset)” on page 6-2.
- D. Make sure the active model and support canister bays have filament loaded to the head (steady green LED).
- E. Make sure the loaded filament matches the material requirements of the CMB file. Change material type if necessary (see “Modeling Materials and Tips” on page 3-8).
- F. The display screen warns you if there is a material mis-match.
- G. Make sure that the tip cleaning brush and tips are clean.
- H. Empty the purge bucket.
- I. If you are using Auto-Cool Down or Energy Saver, or if the material type has changed, allow the oven to heat and stabilize for at least four hours.

2. Modify modeler options:
 - A. Display units - choose inches or metric. See [“Display Units”](#) on page 4-30 for more information.
 - B. User Placement on Platen - allows you to choose the part build location. See [“Part Build Location”](#) on page 4-31 for more information.
 - C. Choose a temperature control option. See [“Oven Temperature Control”](#) on page 4-35 for more information.

Select a Job to Build

1. From the Main Menu select **Build Job** and press ENTER.

```

>Build Job..          |*Tips: Model T16
Operator Control..   |*      Support T16
Modeler Status..
Maintenance..
```

2. Select one of job build options:

```

>Build Next Job:  motor housing <E>
Build Last Job:  rotor <E>
Show Job Queue..          (6 Jobs)
Show Sample Job Queue..
```

- A. **Build Next Job**
 - Selects the first job in the job queue for build.
- B. **Build Last Job** - builds the last job completed.
 - The previous job built by the system will be selected for build.
 - If a previous job does not exist, the screen will show **No Previous Job**.
- C. **Show Job Queue**
 - The job queue is displayed.
 - Position the cursor in front of a specific job in the queue.
 - Press ENTER to select the job for build.
 - For more information on the job queue, see [“Working with the Job Queues”](#) on page 4-29.
- D. **Show Sample Job Queue**
 - The sample job queue is displayed.
 - Position the cursor in front of a specific job in the sample job queue.

- Press ENTER to select the job for build.
 - For more information on the sample job queue, see “Working with the Job Queues” on page 4-29.
3. If **User Placement on Platen** is set to **NO** (system default), the part build will initiate (an Auto Z Stage Zero may be performed depending upon modeler status or settings).
 4. If **User Placement on Platen** is set to **YES**, you are offered the following choices:



Note: For more information about User Placement on Platen see “Display Units” on page 4-30.

```
>Locate Part Start..
  Demo Bounding Box
  Continue..
```

- A. Select **Demo Bounding Box** or **Locate Part Start** to view or change the part build start location.
- B. Select **Continue..** to initiate the part build.

Build Job Warnings

If the system detects an issue that may affect a job build, it displays one of the following warnings:

1. **Head has been changed. Consider tip calibration**
 - Indicates a new head has been installed.
 - Run and verify a calibration part before building jobs. See “XY and Z Tip Offset - Manual Start” on page 6-10.
2. **Change Model (or Support) Canister to ABS (or other material)..**
 - Indicates a mis-match between loaded material and material for which the part (CMB) file was processed.
 - Replace the flagged material canister with proper type.
3. **Need More Model (or Support) Mat'1 (9.1 more)..**
 - The total available material is less than the estimated amount for the part (CMB file).
 - If the system runs out of material before part completion, system will pause the build until material is added.
 - Replace flagged material canister.

4. **Need both (or 4 for 4-bay system) canisters present..**
 - Indicates that at least one operating canister bay does not have material loaded to the Ready mode (flashing green LED).
 - System operation will not be significantly compromised by this condition. The air-dryer circuit performs more efficiently when all operable bays are Ready.
 - Install canisters to the Ready mode for all operating canister bays.
5. **Replace Model (or Support) tip with T12..**
 - Indicates a mis-match between installed tip and tip for which the part (CMB) file was processed.
 - Install the correct tip.
6. **Replace Worn Model (or Support) Tip..**
 - The system tracks the amount of material extruded through a tip. You will receive this prompt when tip performance may start to become compromised. (Tip-life prediction is an estimated value. Many factors contribute to actual tip-life aside from amount of material extruded. Actual tip-life may differ from predicted tip-life.)
 - Replace the flagged tip.
7. **Model / Support Mat'l Incompatibility..**
 - Model and support materials are not of compatible types.
 - Load correct material.
8. **Vacuum not present-Please check build sheet**
 - Vacuum is below minimum for system operation.
 - Correct condition - often the result of a poorly positioned build sheet.
9. **Continue..**
 - You can choose to ignore the warning and 'Continue' the build, but part build quality will be unpredictable.
 - A warning generated from a mis-match of model/support compatibility or from low vacuum cannot be bypassed.

Information Available During a Build

The following information is displayed while building a job:

```
* Job: motor housing (Building)
* Build Time: 0:01 hr of 0:02 hr
* PC 0.1 in3 PC_S 0.1 Mode:Normal
> Modeler Status..      0.010 of 0.950 in
```

- **1st line:** The name of the build job.
- **2nd line:** The elapsed time and total estimated build time -displayed in hours and minutes.
- **3rd line:** The material type and estimated total amount of material for the build. The build mode is also displayed.
- **4th line:** The current height of the job and final Z height of the job.



Note: Press ENTER to go to the System Status screen (see “System Status” on page 4-32).

Pausing or Aborting a Job

1. During a part build, the system can be paused:
 - A. Automatically (canister runs out of material, failure detected, etc.)



Note: If an automatic pause occurs, press the HELP key to view the cause.

- B. Manually - press and hold the PAUSE key on the operator panel for 2 - 3 seconds.
2. When the system is directed to pause:
 - A. The current tool path is completed.
 - B. The Z stage is lowered slightly.
 - C. The head is parked.
 - D. The user display will change to indicate the paused condition.

```
* Job: clip4 (Paused)
>Resume Build <E> | Abort Job..
  Modeler Status.. | Auto Cool: OFF
  Operator Control..
```

3. From Pause mode, you can make the following selections:

- **Resume Build** - the system resumes building the part. If the oven door, top door, or top hood is open, or if vacuum is not present, the screen will display **Can't Resume (Help)**.
- **Modeler Status** - View the Job Status and Canister Status.
- **Operator Control** - Unlock the door/hood, clean tips, change materials (including load/unload and canister removal/installation), move the head, or move the Z stage.
- **Abort Job** - Aborts the current job.
- **Auto-Cool** - The auto-cool down setting can be changed for the current job only. See [“Oven Temperature Control” on page 4-35](#) for more information.

After a Job Build



Warning: Wear proper safety equipment when handling items inside the oven. Surfaces in the build chamber can be very hot.

1. The system performs the following actions:
 - A. The Z stage is lowered and the head is parked.
 - B. If Auto Cool-Down is ON the oven automatically cools to the standby temperature. See [“Oven Temperature Control” on page 4-35](#) for more information.
 - C. The screen displays **Done**, and prompts you to remove the part.
 - D. If the build has been terminated abnormally, press HELP to list the reason for the termination.
2. Remove the part from the system.



Note: If Auto Cool-Down is active, allow the oven to cool to the standby temperature before removing the part.

- A. Open the oven door.
- B. Push up on the edge of the build sheet to release the vacuum grip.



Caution: Do not attempt to remove a part from the build sheet while the build sheet is on the platen. Damage to the platen or the platen level may occur.

- C. Remove the build sheet from the platen.



Caution: Use extreme care when cleaning the platen. If using a brush, brush away from the vacuum port in the center of the platform. If debris falls into the vacuum port, it can cause a loss of vacuum, resulting in poor adhesion of the build sheet during building.

- D. Remove debris that may have fallen onto the platen - use a vacuum or a soft brush.
3. Carefully peel the part from the build sheet.
 - If the part does not peel easily, use the metal scraper included in your Startup Kit to carefully pry the part from the sheet.
 - The build sheet is intended for one-time use. Do not turn a build sheet over and place it on the platen. Material residue on the sheet can adhere to the platen or interfere with the build sheet vacuum.
4. Press ESCAPE to return to the Main Menu.
5. Remove supports from the completed part.

Removing Supports

Breakaway Support Material

PC material uses break-away supports, called BASS. This material must be removed manually.



Warning: Wear safety goggles and LEATHER gloves (provided in Startup Kit) when removing breakaway supports

Remove the support material carefully. The material should break away with relative ease. If necessary, use needle nose pliers, probes, an Exacto knife, or a pick to remove the supports. Use special care for sections of the part that are fragile or thin.

Soluble Release Support Material

Soluble Release support material is used with ABS-M30, ABS-ESD7, ASA and PC-ABS material. After building a part, you can remove supports by using an Ultrasonic or Circulation tank containing a solution of water and WaterWorks soluble solution.

For more information on WaterWorks, refer to the WaterWorks User Guide located on Stratasys' Customer Extranet.

Support Material for PPSF Parts

Removing supports from PPSF parts requires a slightly different support removal process than with ABS, ASA or PC, which uses BASS supports. With PPSF, the interface layer of the support (the layer that contacts the part) can be pulled or removed from the part easier if the part is hot; the heat makes it flexible and less brittle.

 **Note:** Remove the part from the PPSF build sheet as soon as possible after removing it from the oven.

Remove the supports immediately after the part is built. If you can't remove the supports immediately, reheat the part to between 160° C and 220° C (320° F to 428° F). You can use the modeler oven, or another oven that can reach the necessary temperatures, to reheat the part.

 **Note:** Removing supports from two or more parts at a time is most efficient when reheating parts. You can remove supports from one part while the others are heating up.

The difficulty of support removal is based on the following: part size, amount of supports, support style, and support temperature. StratasyS recommends removing the supports in the following order:

1. Base
2. Structures
3. Thin horizontal sections
4. Around small features
5. Angle support faces
6. Large mass sections

 **Note:** If the support structures become brittle or hard to remove, reheat the part in the oven.

Material, Canisters, and Liquefier Tips

Unloading Material from the Liquefier Tips

 **Note:** If you are changing to a different material type or changing tips, follow the procedure outlined in “Changing Tips or Material Type” on page 4-22.

 **Note:** Unloading filament from the liquefiers is done in the Idle or Paused mode only, not while building.

1. Make sure the system is in **Pause** or **Idle** mode.
2. From the Main Menu, select **Operator Control** and press ENTER.

```
Build Job..          |*Tips: Model T16
>Operator Control.. |*      Support T16
Modeler Status..
Maintenance..
```

3. Select **Load/Unload Mtl..** and press ENTER.

```
Unlock Door <E>      | Calibrate..
>Load/Unload Mtl..  | Temp Control..
Change Tips/Mtl..   | Move Head/Stage..
```

4. Select **Unload Material..** and press ENTER.

```
Load Material..
>Unload Material..
Material Status..
Unplug Tips..
```

5. Select the canister/material to be unload and press ENTER.

```
M1L:PPSF  92.0 in3      (Ready)
>M2L:PC    91.6 in3 <E> (Loaded)
S1L:PC_S   92.3 in3      (Ready)
S2L:PPSF_S 41.4 in3      (Ready)
```

- The head warms up to the unload temperature, and the canister LED rapidly flashes green.
- The head drive motors and canister drive motor turn in reverse. The material is pulled back from the head about 4-6 inches (102-152 mm).

 **Note:** For some materials (i.e., SR20), a tip purge is performed before the material is unloaded from the liquefier.

- The head temperature lowers to standby temperature and the canister LED turns to a slower flashing green (same flash rate as used to indicate canister Ready condition).

- The display will show ***AtHead** for the unloaded material.
6. Replace the canister. Refer to “[Removing Canisters](#)” on page 4-14, “[Canister Installation](#)” on page 4-15, and “[Handling/Storing Canisters](#)” on page 4-21.

Removing Canisters

1. Removing an Empty Canister
 - A. Raise the drive block off the canister by lifting the drive block lever.
 - B. Pull the canister out of the bay.



Note: Empty canisters have a small, unusable volume of material remaining. The leftover material allows manufacturing tolerances and ensures that Auto Changeover works properly.

- There will be a piece of material, approximately 2 inches (50.8 mm) in length, that extends beyond the filament exit hole. When removing an SR20 support canister, this piece may break off as the canister is removed. Make sure that the broken piece drops out of the drive block. If necessary, remove the drive block inlet to remove this piece of material.
2. Removing a Partially Used Canister (refer to [Figure 4-3](#) for referenced item numbers).
 - A. Unload filament from the liquefiers (see “[Unloading Material from the Liquefier Tips](#)” on page 4-13).
 - B. After **Unload Complete** is displayed on the user panel, open the canister thumbwheel door (item 3).
 - C. Re-insert the square foam gasket (item 7A) into the thumbwheel door.
 - D. Close the thumbwheel door.
 - E. Raise the drive block off the canister by lifting the drive block lever.



Caution: IMMEDIATELY pull the canister from the bay after lifting the drive block lever. A delay may allow filament to be forced into the canister. If filament is forced into canister, cross winding is likely, making the entire canister unusable.

- F. Immediately pull the canister out of the bay (within ten seconds of lifting the drive block lever).

- c. When the drive block lever is raised, the drive block motor runs in reverse and pulls material from the system.



Caution: Discard material pulled from system. Do not attempt to rewind material in canister. If filament is forced into canister, cross winding is likely, making the entire canister unusable.

- b. The excess material accumulates in the empty drive bay.
- c. As the end of the filament exits the filament present switch, the canister-drive motor stops.
- G. Cut the filament flush with the top of the canister snout.
- H. Remove the plastic plug from its storage location (item 6B) and insert it into the filament outlet hole of the canister snout (item 4 & 6A).
- I. Pull remaining filament from the drive block and discard all accumulated material in the drive bay.
- J. To Install a Canister see [“Canister Installation” on page 4-15](#).

Canister Installation

1. Install the Canister (refer to [Figure 4-3](#) for referenced item numbers):
 - A. For new canisters, peel back the foil tape (item 1) on the side of the canister.
 - B. Remove and discard the anti-rotation plug (item 2).
 - C. Reseal the canister hole with the reusable foil tape by pressing it firmly against the canister to establish an airtight seal.
 - D. Pick up the canister by grasping the plastic snout (item 4).
 - E. Rest the canister on the edge of the bay - do not push the canister fully into the bay.



Caution: Do not remove the plastic cap until you are ready to preload the filament into the drive block.

- F. Remove the plastic plug (6A) on top of the snout.
- G. Snap the plastic plug into the storage slot (6B).
- H. For new canisters, prepare the filament (5) for loading:
 - a. Open the thumbwheel (3) door on the front of the canister.

- b. Cut the filament below its bend so that the filament end is flush with the top filament outlet of the snout.



Note: The cut end of the filament must be square.

- c. Close the thumbwheel door (do not remove foam center from gasket yet).
- l. Push canister all the way into the canister bay.

Figure 4-3: Canister Installation

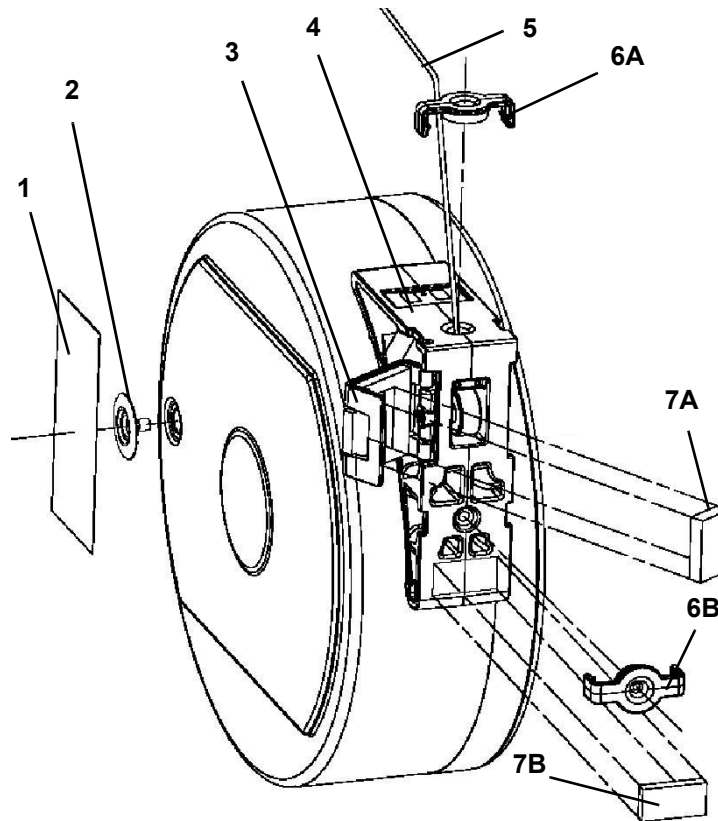

Key to Figure 4-3

Item	Description	Item	Description
1	Foil Tape	6A	Plastic Plug (sealing position)
2	Anti-Rotation Plug	6B	Plastic Plug (stowed position)
3	Thumbwheel Door	7A	Foam Gasket (sealing position)
4	Canister Snout	7B	Foam Gasket (stowed position)
5	Filament		

- J. Drop the filament drive block down onto the canister by pulling out the canister drive lever. (Figure 4-4)
 - Verify that the filament drive is aligned with the filament exit.
 - The LED is OFF at this point.
 - After about five seconds, the SmartSpool chip is read by the system and the drive block motor starts turning.
- K. Perform “Preload Filament to the Drive Wheels” on page 4-17.

Figure 4-4: Preloading Filament

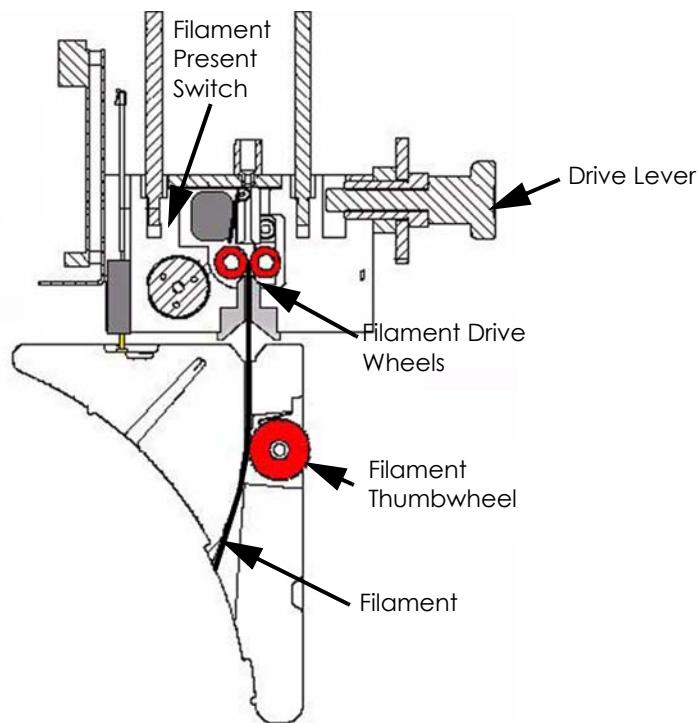

2. Preload Filament to the Drive Wheels
 - A. Open the thumbwheel door.
 - B. Remove the square foam gasket on the inside of the thumbwheel door. (Figure 4-3)
 - C. Stick the gasket onto the canister.
 - The square foam gasket prevents the thumbwheel from moving.
 - The gasket must only be removed when the canister is in the system.
 - The gasket is re-used if the canister is to be stored.

- D. Feed the filament into the filament drive mechanism by pressing in and down on the thumbwheel. (Figure 4-4)
- E. Turn the wheel until you feel the filament drive motor pull the filament.
 - The filament needs to be advanced approximately 2 inches (50.8 mm) to reach the drive motor drive wheels.
- F. The system automatically completes the preloading of the filament.
 - The drive motor advances the filament until it contacts the filament present switch.
 - The drive motor stops, and the LED turns to green flashing.



Caution: Make sure that the thumbwheel door is closed after filament preload is accomplished.

- G. Close the thumbwheel door.
- H. Load material to the head (see “Loading Material to the Liquefier Tips” on page 4-18).

Loading Material to the Liquefier Tips



Note: If you are changing to a different material type or changing tips, follow the procedure outlined in “Changing Tips or Material Type” on page 4-22.



Note: Loading filament to the liquefiers is done in the Idle or Paused mode only, not while building.



Caution: If the material type is changed, the Tips must be changed.

1. Make sure the system is in **Pause** or **Idle** mode.
2. From the Main Menu, select **Operator Control** and press ENTER.

Build Job..	*Tips: Model T16
>Operator Control..	* Support T16
Modeler Status..	
Maintenance..	

3. Select **Load/Unload Mtl..** and press ENTER.

Unlock Door <E>	Calibrate..
>Load/Unload Mtl..	Temp Control..
Change Tips/Mtl..	Move Head/Stage..

4. Select **Load Material..** and press ENTER.

```
>Load Material..  
  Unload Material..  
  Material Status..  
  Unplug Tips..
```

5. Select the material to be loaded and press ENTER. (The <E> indicates the canisters that you can select.)



Note: Model and support materials must be compatible. If a selected material is incompatible with a loaded material, a material mis-match load error will occur. The selected material will not be loaded.

```
>M1L:PPSF   92.0 in3 <E> (Ready)  
M2L:PC      91.6 in3   (Loaded)  
S1L:PC_S    92.3 in3   (Loaded)  
S2L:PPSF_S  41.4 in3 <E> (Ready)
```

- A. The head warms up to the material operating temperature (Automatic - based on SmartSpool data). This step also sets the oven temperature to the correct value for the material being loaded.
- B. The canister drive motor starts to push the filament to the liquefier tips.



Note: For some materials (i.e., SR20) the order of steps A and B are reversed.

- C. When the filament reaches the head (takes 2 to 4 minutes), it enters the liquefier tip, and the tip purges a small amount of material.
- D. A successful load is indicated by a steady green LED. A complete load and purge cycle should take less than five minutes.

Canister Auto Change-over



Note: Included as part of the 4-bay system option. Not available with standard 2-bay system.

1. Auto Changeover allows you to leave a long part build unattended.
2. When an active canister becomes empty:
 - A. The system is paused and the canister drive automatically withdraws residual material from the system.
 - B. The full canister is pre-loaded, and then material is loaded to the head. The build job is automatically resumed.



Note: If the material to be loaded is not the same as the material it is replacing, a material mis-match load error will occur. The auto changeover will not occur and the system will enter Pause mode.

3. While the changeover is taking place, the user panel displays:

```
* Auto Changing Material*
* On Model Head          *
  Please Wait .....
```

- No user interaction is required.
 - Auto Changeover takes about five minutes.
4. If you press the Pause key during an Auto Changeover, the system will remain paused after the changeover is complete.
 - You need to select Resume on the screen to continue building.
 5. If an error occurs during the Auto Changeover process, the system will remain paused.
 - Press the HELP key to determine the cause of the error.
 - Once the error is resolved, select **Resume** on the screen to continue the build job.

Handling/Storing Canisters



Caution: How material canisters are handled and stored has a direct impact on part build quality. Like most engineering plastics, the filament within the canisters can absorb moisture. Filament moisture causes poor model surface quality.

1. Each canister holds 92 in³ (1510 cc) of filament material. The canister also contains desiccant material to absorb moisture.
2. A removable plastic cap and a thumbwheel door provide an airtight seal to keep moisture from entering the canister while stored.



Caution: Make sure that you insert the square foam gasket under the thumbwheel door and place the plastic cap over the filament outlet hole when storing a canister. In less than one hour, in an unsealed canister, filament can absorb enough moisture to become unusable.

3. If a canister containing material is removed from the system, or remains in the system in a non-ready state (LED is OFF), it should be stored as follows (refer to [Figure 4-3](#) for referenced item numbers):



Note: When the filament is in a ready or loaded state (flashing green LED or steady green LED), and the canister door is closed, the system air-dryer system constantly purges moisture from the canister.

- A. Open the thumbwheel door (item 3) and insert the square foam gasket (item 7A) (stored on the canister - item 7B) into its thumbwheel door location.
- B. Close the thumbwheel door - make sure that it is completely closed.
- C. Remove the plastic cap from its stowed position (item 6B) and insert it into the filament outlet hole of the canister snout (item 4 & 6A).
- D. Store canisters in an upright position, do not lay them flat.

Changing Tips or Material Type

 **Note:** If you are changing tips, or changing to a different material type, the user interface has a menu selection that guides you through the process.

 **Caution:** If the material type is changed, the Tips must be changed.

1. Clean the oven and the tip wipe assembly.

 **Note:** Residue from lower temperature materials can melt and drip onto higher temperature parts if cleaning is neglected.

2. Inspect the tip wipe assembly (refer to “Clean/Inspect Tip Wipe Assembly” on page 7-5).
3. From the Main Menu select **Operator Control** and press ENTER.

```
Build Job..          |*Tips: Model T16
>Operator Control.. |*      Support T16
Modeler Status..
Maintenance..
```

4. Select **Change Tips/Mtl..** and press ENTER.
 - The Change Tips/Mtl. menu is designed to guide you through the steps necessary to complete a material type change, or a tip replacement procedure.
 - Select each step sequentially, from top to bottom, within each displayed menu screen.
 - Skip steps only if they are not relative to the procedure being accomplished (a tip may be changed without changing material type; a material type change should always be accompanied by a tip change).
 - Some steps are not selectable - indicated by an * preceding a number, i.e. *2, *3. They are provided as a convenience to guide you through the procedure in the appropriate sequence of steps.

```
Unlock Door <E>     | Temp Control..
Load/Unload Mtl..  | Move Head/Stage..
>Change Tips/Mtl..
Calibrate..
```

5. Select **Unload Model and Support..** and press ENTER.

```
>Unload Model and Support.. <E>
*2. Insert new canisters (if required)
*3. Install tips
Select Materials/Tips..
```

- The head warms up to the material operating temperature, and the canister LED rapidly flashes green.
 - Once the necessary temperature is reached, the head drive motors and canister drive motor turn in reverse. The material is pulled back from the head about 4-6 inches (102-152 mm).
 - The head temperature lowers to standby temperature and the canister LED turns to a slower flashing green (same flash rate as used to indicate canister Ready condition).
6. If changing material type, follow the procedures outlined in “[Removing Canisters](#)” on page 4-14 and “[Canister Installation](#)” on page 4-15.
 7. If the liquefier tips are to be changed:



Warning: Always use an approved ladder or step stool when working with components under the top hood.

- A. Open the top door and top hood.
- B. Place the head in the head maintenance bracket (refer to “[Head Maintenance Bracket](#)” on page 3-6).
- C. Loosen the two captive screws that clamp each liquefier tip in place. Remove the tips.

Figure 4-5: Liquefier Retaining Screws

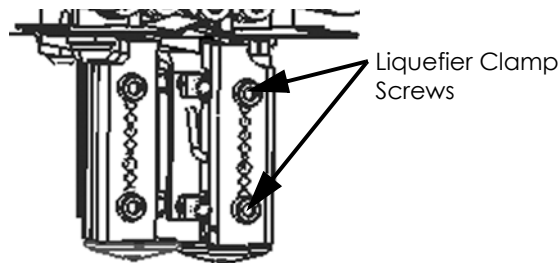

- D. Place the new liquefier tips in the head. Tighten the clamp screws.



Note: Make sure the tips are fully inserted into heater block before tightening the clamp screws ([Figure 4-6](#)).

- See “[Liquefier Tips and Slice Heights](#)” on page 3-9 for tip selection and material compatibility.

Figure 4-6: Tip Installation

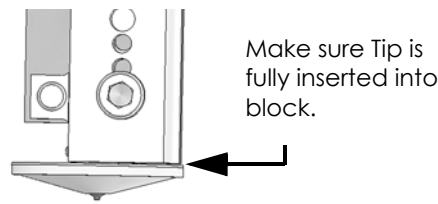

- E. Remove the head from the maintenance bracket and place it back in the gantry. Tighten the two captive screws - close the top hood and top door.

i **Note:** Make sure the filament tubes, umbilical cable, and air hose are not tangled and are routed correctly.

8. Choose **Select Materials/Tips..**

```
Unload Model and Support.. <E>
*2. Insert new canisters (if required)
*3. Install tips
>Select Materials/Tips..
```

- A. Material information is displayed across the top line of the display.
- a. *M - labels the first half of the line as model information.
 - b. The type of model material selected for loading to the liquefier is shown.
 - c. Between two brackets, '[]', canister bay information is provided. '|' separates the individual bays.

i **Note:** Selection of material for loading is made from the Review Materials to Load.. menu.

- 2-bay systems display information for two bays; 4-bay systems display information for four bays.
- R - indicates that the material canister is pre-loaded and can be selected for loading to the liquefier.
- * - indicates that the material canister is pre-loaded and is selected for loading to the liquefier. If a material has been unloaded from the liquefier, but the canister has not been removed (only the tip is replaced), the material will still be at the head. By default, this is the 'selected' canister for loading to the liquefier - a * is shown on the display for this bay.
- E - indicates that the installed canister is empty.
- If the bay does not have a canister, the space for the bay information is left blank.

- d. The type of support material selected for loading to the liquefier is shown.
- e. S* - labels the second half of the line as support information.

```
*M      PC [R | * | * | R ]PC_S      S*
>Review Materials to Load..
Select Tips <E> T12 T12
Reset Tip Odometers..
```

- B. Three sequential menu items are available - **Review Materials to Load..**, **Select Tips**, and **Reset Tip Odometers..**



Note: It is recommended that you select each option sequentially, from top to bottom, dependent upon your needs (a tip may be changed without changing material type; a material type change should always be accompanied by a tip change).



Note: As this sequence of menus always assumes that a tip has been changed, a system calibration must occur before part build can be accomplished. Material load and system calibration are available from the **Reset Tip Odometers..** menu.

- C. **Review Materials to Load...** Material bay canister information is displayed - type, amount remaining, and status.

- i. To select a material, move your cursor to that line and press ENTER. The canister status will be displayed to the far right of the screen.

```
>M1L:PPSF 92.0 in3 <E> (Ready)
M2L:PC 91.6 in3 (*Ready)
S1L:PC_S 92.3 in3 (*Ready)
S2L:PPSF_S 41.4 in3 (None.)
```

- **(*AtHead)** - indicates that the material is loaded to the head, but not to the liquefier tip (if material has been unloaded, but the canister has not been removed from the bay, the material backs out of the tip and remains in the head). By default, this is the material selected for loading to the tip. A different material type cannot be selected for loading to that tip unless the ***AtHead** material canister is removed from the system (causing the material to empty from the system).
- **<E> (Ready)** - indicates that the material is pre-loaded and can be selected for loading to the liquefier tip.
- **(*Ready)** - indicates that the material is the current selection for loading to the liquefier tip.
- **(None.)** - indicates that a canister is installed, but has not been pre-loaded to the canister bay drive wheels.

- ii. Press MENU to return to the previous screen. Go to the **Select Tips** menu.



Note: Selected materials will be loaded as a part of the last item in this sequential menu - the Reset Tip Odometers.. item.

b. **Select Tips**

- i. Move the cursor to the Select Tips line.



Caution: The modeler cannot detect the type or size of installed tips. The operator must correctly select the installed tips from the 'Select Tips' menu. If the tips selected on the menu do not match the installed tips, part quality will be affected and liquefier clogs will likely occur.

- ii. Press ENTER to toggle through the available tips until the display matches the tips installed in the system.
- iii. Only tips that are compatible with the loaded material will be displayed.
- iv. Go to the **Reset Tip Odometers..** menu.

```
*M      PC [R | * | * | R ]      PC_S      S*
Review Materials to Load..
Select Tips <E> T12 T12
>Reset Tip Odometers..
```

C. **Reset Tip Odometers..**

```
>Reset Model in3 <E> 633.5 ()
Reset Supp. in3 <E> 182.7 ()
-----
Unlock Door <E>
```

- i. Move the cursor to the line of the tip that was replaced.
- ii. Press Enter to reset the odometer to zero (0.0)
 - If a tip is removed that may be re-installed at a later time, before resetting the tip odometer, record the displayed odometer reading. Store the reading with the tip that was removed.
 - If a used tip is installed for which previous odometer information is available, enter the stored reading of the used tip (use the number keys and decimal (.) key), then press ENTER.
- iii. If the build sheet needs to be installed, select **Unlock Door**, press Enter, and install a new build sheet.
- iv. Move the cursor to the third line of the **Reset Tip Odometers..** menu.



Note: The menu choice displayed on the third line is dependent upon the part build location chosen for the system. For more information, see "[Part Build Location](#)" on page 4-31.

- v. If user placement is set to **NO** (system default is **NO**), the third line will read: **Load and Calibrate..**
 - Press ENTER

```

Reset Model in3 <E> 633.5 ()
Reset Supp. in3 <E> 182.7 ()
>Load and Calibrate..
Unlock Door <E>

```

- vi. If user placement is set to **YES**, the third line will read: **Select Calibration Part Position..**

```

Reset Model in3 <E> 633.5 ()
Reset Supp. in3 <E> 182.7 ()
>Select Calibration Part Position..
Unlock Door <E>

```

- a. Press ENTER.
- b. Make placement selections (**Locate Part Start..**, **Demo Bounding Box** - for more information see “Part Build Location” on page 4-31.

```

Locate Part Start..
Demo Bounding Box <E>
>Load and Calibrate..

```

- c. Then select **Load and Calibrate..**
- vii. Selecting **Load and Calibrate..** initiates a sequence of automated system calibration and material load.
- viii. The oven and oven temperature must stabilize. Oven stabilization times for the material you are running are listed in [Table 4-1](#).

```

*   Waiting h:mm to stabilize   *
** Actual 100 C Setpoint: 225 C **
>Unlock Door <E> | *
Calibrate Immediately <E>

```

Table 4-1: Oven Stabilization Times (in hours)

Current Oven Temp.	Material Type Being Installed								
	ABSi	ABS-M30	ABS-ESD7	ASA	Nylon 12	PC-ABS	PC	Ultem* 9085	PPSF
Room temp.	4	4	4	4	4	4	4	8	8
ABS-M30, ABSi Auto Cool-Down	---	---	---	---	---	4	4	6	6
ABS-ESD7	---	---	---	---	---	4	4	6	6
ASA	---	---	---	---	---	4	4	6	6
Nylon 12	---	---	---	---	---	4	4	6	6
PC-ABS	4	4	4	4	4	---	4	6	6
PC	4	4	4	4	4	4	---	4	4
Ultem* 9085	6	6	6	6	6	4	---	---	6
PPSF	6	6	6	6	6	6	4	---	---

ix. The system performs Auto Z Stage Zero calibration.

 **Note:** If the Auto Z Stage Zero calibration fails, you need to run “Manual Z Stage Zero” on page 6-6. You then have to navigate through the screens to get back to this step.

```
* Calibration Activity *
      Please Wait ...
```

x. The system performs Auto Tip-to-Tip Calibration.

 **Note:** If the Auto Tip-to-Tip Calibration fails, you can manually perform the calibration (see “Auto Tip-Tip Calibration (AutoCal Tip Offset) - Manual Start” on page 6-9). You can manually build the calibration job shown on “XY and Z Tip Offset - Manual Start” on page 6-10.

```
* Tip to Tip Calibration Activity *
      Please Wait...
```

xi. The system loads model and support material.

 **Note:** If model or support loading fails, manually load or unload the material (“Material, Canisters, and Liquefier Tips” on page 4-13 and “Loading Material to the Liquefier Tips” on page 4-18). You then have to walk through the screens to get back to this step.

```
*Loading.      Please Wait...
*              Current   Setpoint
* Model       : 234°C    / 325°C
* Support     : 234°C    / 325°C
```

xii. A calibration part is built.

 **Note:** If the Calibration Job fails, you can manually build the calibration job. See “XY and Z Tip Offset - Manual Start” on page 6-10.

```
*Job: Calibration Job (Building)
*Build Time: 0:04 hr of 0:08 hr
*PC      0.1 in3 PC_S 0.0
>Modeler Status.. 0.010 of 0.050 in
```

- Check the Calibration Job for tip offset corrections. See “XY and Z Tip Offset Calibration” on page 6-2 for more information.

Working with the Job Queues

1. There are two, separate, job queues available on the 360mc/400mc - the Job Queue; and the Sample Job Queue.
2. From the Main Menu select **Build Job** and press ENTER.

```
>Build Job..          |*Tips: Model T16
Operator Control..   |*      Support T16
Modeler Status..
Maintenance..
```

3. Select **Show Job Queue**, or **Show Sample Job Queue**, and press ENTER.



Note: The total number of jobs currently in the queue is displayed at the end of the line.

```
Build Next Job:  motor housing <E>
Build Last Job:  rotor <E>
>Show Job Queue..          (6 Jobs)
Show Sample Job Queue..    (jobs for cfg)
```

- A. The **Show Job Queue** menu - contains files downloaded from the Insight application on your PC workstation. (For information on Insight, see “Operating Insight” on page 5-1.)
 - Up to four jobs can be viewed on the display panel.
 - If the job queue contains more than four jobs, use the arrow keys to scroll the display up or down through the available jobs.
 - Use the arrow keys to select a job in the queue.
 - Press the Enter key to build a selected job.
 - Press the <.> (dot) key to show the details of the selected job.
 - Press 1 to move a selected job to the top of the queue.
 - Press DEL to delete a selected job from the queue.
 - Press 9 to copy the job to the sample queue (job queue only).
- B. **Show Sample Job Queue** menu - contains files that are helpful for testing the system. The 360mc/400mc comes with several sample job files permanently installed on the system. These files cannot be deleted (For the Sample Job Queue the (DEL) key does not delete pre-installed sample job files).
 - Press the <.> (dot) key to toggle between all sample jobs and only jobs for the current system configuration.
 - Up to four jobs can be viewed on the display panel.

- Use the arrow keys to scroll up or down through the available sample jobs, or to select a job in the sample queue.
- Press the Enter key to build the selected job.
- Additional files can be stored in the sample job queue from the standard job queue (press 9 to copy a job from the standard job queue into the sample queue).
- User-added sample job files can be deleted by pressing the DEL key.

Change Modeler Default Values

Factory presets can be changed from the **Modeler Default..** menu.

1. From the Main Menu select **Maintenance** and press ENTER.

```
Build Job.. |*Tips: Model T16
Operator Control.. |*      Support T16
Modeler Status..
>Maintenance..
```

2. Select **Modeler Default..** and press ENTER.

```
>Modeler Default..
Administration..
Reboot system..
Measure Flatness <E>
```

Display Units

Select **Display Units**. Inches or metric can be selected (factory setting is in inches)

```
> Display Units = in (Inches) <E>
User Placement on Platen: No
```

Part Build Location

The part build location can be viewed or changed from the **User Placement on Platen** menu (press ENTER to toggle between **YES** and **NO**).

1. If User Placement is set to **NO** (default) - the part will build in the center of the platen.
2. If User Placement is set to **YES** - the position of the front, left corner of the bounding box (the imaginary box surrounding the part - used by the modeler to define part placement on the platen) can be viewed or changed from the following menu:



Note: This menu is displayed when a part is sent to build (refer to “Select a Job to Build” on page 4-6).

```
>Locate Part Start..  
Demo Bounding Box <E>  
Continue..
```

- A. To change the start location, select **Locate Part Start..** and press ENTER.

```
* * * Use the 2, 4, 6, 8 Keys * * *  
Press 1: Coarse Moves: 1.000 in  
>Press 0: Fine Moves: 0.100 in  
* * * Press ENTER to Set New XY Start * * *
```



Note: The up and down arrows have no effect when this menu is displayed.

- Press the 2, 4, 6, or 8 key to move the head in the -y, -x, +x or +y directions respectively.
 - Press the 0 or 1 key to select Coarse or Fine movement of the head.
 - Press ENTER to select the current head position as the new start location (front, left corner) for the next part.
- B. To view the current start location, select **Demo Bounding Box <E>** and press ENTER. The head will move along the bounding box outline of the current start location.
- C. Select **Continue..** and press ENTER to accept the current start location.
- If user placement is **YES**, an Auto Z Stage Zero will be done at each part start near the center of the bounding box.
 - If user placement is **NO**, an Auto Z Stage Zero will be done near the center of the platen after powering on the system.

- An Auto Z Stage Zero is also performed if the oven temperature has been unstable during a six-hour time period before a part is built.

System Status

The user interface can be used to display each of the following:

- Temperature Status
- Odometer Status
- Material Status
- System Software Version
- Other System Information

Temperature Status

To view the current and setpoint temperatures for the oven and liquefiers:

1. From the Main Menu select **Modeler Status** and press ENTER.

```
Build Job..          |*Tips: Model T16
Operator Control..  |*      Support T16
>Modeler Status..
Maintenance..
```

2. Select **Temperatures** and press ENTER. The current and setpoint temperatures are displayed

```
>Temperatures..
Material Status..
Tip Status..
Machine State
```

```
*           Current Setpoint
* Oven:78° C / 80° C
* Model:198° C / 200° C
* Support:301° C / 300° C
```

Odometer Status

The system tracks and displays the total amount of material extruded through a liquefier tip since it was last replaced. To view the tip odometers:

1. From the Main Menu select **Modeler Status** and press ENTER.

```
Build Job..          |*Tips: Model T16
Operator Control..  |*      Support T16
>Modeler Status..
Maintenance..
```

2. Select **Tip Status** and press ENTER. The current status of the tips is displayed.

```

Temperatures..
Material Status..
>Tip Status..
Machine State

* Mat'l amount
*Model tip   :   13.0 in3
*Support tip :   54.0 in3
*Tips: Model <T16>   Support <T16>..

```

Material Status

You can find the current status of each material canister.

1. From the Main Menu select **Modeler Status** and press ENTER.

```

Build Job..          *Tips: Model T16
Operator Control..  |*      Support T16
>Modeler Status..
Maintenance..

```

2. Select **Material Status** and press ENTER. All active canisters are shown.

```

Temperatures..
>Material Status..
Tip Status..
Machine State

** Model  1:  PC      56.4  in3  (Loaded)
*  Model  2:                in3  (None)
** Support 1: PC_S   21.4  in3  (Loaded)
*  Support 2:                in3  (None)

```

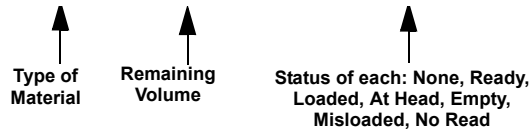

System Software Version

The system can display the version of the software used to control the modeler (this software is installed on the modeler hard drive, not to be confused with Insight software installed on the workstation PC).

1. From the Main Menu select **Modeler Status** and press ENTER.

```
Build Job..          |*Tips: Model T16
Operator Control..  |*      Support T16
>Modeler Status..
Maintenance..
```

2. Select **Machine State..** and press ENTER. The the current software version is displayed on the bottom line.

```
Temperatures..
Material Status..
Tip Status..
>Machine State
```

```
Sensor States..
System Status..
UPS Status..
>360mc/400mc v2.x.x
```

Sensor, System, or UPS Status

Other available status displays:



Note: The Envelope size and the materials that can be used on your system are listed under System Status.

1. From the Main Menu select **Modeler Status** and press ENTER.

```
Build Job..          |*Tips: Model T16
Operator Control..  |*      Support T16
>Modeler Status..
Maintenance..
```

2. Select **Machine State..** and press ENTER.

```
Temperatures..
Material Status..
Tip Status..
>Machine State
```

3. Select **Sensor States.., System Status.., or UPS Status..** Press ENTER.

Miscellaneous Operating Tasks

Oven Temperature Control

The oven modeling temperature is determined by the loaded material type. It is controlled by the system software and cannot be modified. However, the operator does have control of some oven temperature functions.

- **Set Oven to Build Temp** - The oven will heat to the system controlled build temperature for the loaded material.
- **Cool Down Oven to** - The oven will cool to system controlled standby temperature for the loaded material.
- **Auto Cool Oven** - The oven will cool incrementally until the system controlled standby temperature is reached - this takes about 30 minutes. This option acts as an energy saver when PC, PC-ABS, or PPSF materials are being used. It also helps to prevent part cracking when building large, thick parts with PPSF. Auto-cool down can be set to **After Next Job**, **After Every Job**, or **OFF**.
- **After Next Job**: After the next job is built and auto-cooled, the auto-cool down mode will automatically reset to OFF.
- **After Every Job**: After every job is built and auto-cooled, the oven temperature will stay at the material's standby temperature.
- **OFF**: After every job is built, the oven temperature will stay at the material's build temperature.

To control oven temperature:

1. From the Main Menu select **Operator Control** and press ENTER.

```
Build Job..          |*Tips: Model T16
>Operator Control.. |*      Support T16
Modeler Status..
Maintenance..
```

2. Select **Temp Control** and press ENTER.

```
Unlock Door <E>     |>Temp Control..
Load/Unload Mtl..  | Move Head/Stage..
Change Tips/Mtl..
Calibrate..
```

3. Select one of the temperature parameters (as shown below) and press ENTER.

```
Set Oven to Build Temp: 145° C <E>
Cool Down Oven to:      85° C <E>
>Auto Cool Oven:        OFF <E>
```

Operator Control of Head and Z Stage Movement

1. Moving the Head to the Head Service Location (and Service Bracket).
 - A. From the Main Menu select **Operator Control** and press ENTER.

Build Job..	*Tips: Model T16
>Operator Control..	* Support T16
Modeler Status..	
Maintenance..	

- B. Select **Move Head/Stage** and press ENTER.

Unlock Door <E>	Calibrate..
Load/Unload Mtl..	Temp Control..
Change Tips/Mtl..	>Move Head/Stage..

- C. Select **Move Head to Service Location** and press ENTER.

>Move Head to Service Location <E>
Move Head to Center-Front Location <E>
Move Z Stage to Bottom <E>
Move Relative..

- D. Open the hood door and hood lid.
 - E. Loosen the two #8 socket head cap screws on the head.
 - F. Place the head in the service bracket by aligning it with the bracket pins.
 - G. Tighten one of the #8 socket head cap screws on the head.

2. Moving the Z Stage to Bottom of Travel.

- A. From the Operator Control Panel, select **Operator Control** and press ENTER.

Build Job..	*Tips: Model T16
>Operator Control..	* Support T16
Modeler Status..	
Maintenance..	

- B. Select **Move Head/Stage** and press ENTER.

Unlock Door <E>	Calibrate..
Load/Unload Matl..	Temp Control..
Change Tips/Matl..	>Move Head/Stage..

- C. Select **Move Z Stage to Bottom** and press ENTER.

Move Head to Service Location <E>
Move Head to Center-Front Location<E>
>Move Z Stage to Bottom <E>
Move Relative..

3. Incrementally Moving the Z Stage and Head.

A. Set the amount of movement the Z Stage and Head will move with each movement command.

a. From the Operator Control Panel, select **operator Control** and press ENTER.

```
Build Job.. | *Tips: Model T16
>Operator Control.. | * Support T16
Modeler Status..
Maintenance..
```

b. Select **Move Head/Stage** and press ENTER.

```
Unlock Door <E> | Calibrate..
Load/Unload Matl.. | Temp Control..
Change Tips/Matl.. | >Move Head/Stage..
```

C. Select **Move Relative** and press ENTER.

```
Move Head to Service Location <E>
Move Head to Center-Front Location<E>
Move Z Stage to Bottom <E>
>Move Relative..
```

d. Select **Set Distance** and press ENTER.

- Press the ENTER to change the distance the Z Stage and Head will move with each movement command. Each time the ENTER key is depressed the amount of movement will change. The available distance options are: 0.001, 0.010, 0.100 and 1.000 inches (0.01, 0.10 and 1.0 and 10 mm).

```
>Set Distance= 0.100 in <E>
*Move Head: +X <6> -X<4> +Y <2> -Y <8>
*Move Z Stage: +Z <9> -Z <3>
*Current: X: 0.000 Y: 0.000 Z: 0.000
```

 **Note:** The current position of the head and stage are displayed on the last line. The current values are based on the following coordinate system. Z = 0.0 when the model tip is on the build sheet, X = 0.0 on the left side of the oven, and Y = 0.0 at the front of the oven.

 **Warning:** When moving the Z stage, be careful not to run it into the head. When the Z stage gets close to the top, toggle the set distance to 0.010 (0.254 mm) or 0.001 inches (0.0254 mm).

B. To move the Z Stage:

 **Note:** Each time a number key is depressed, the Z Stage will move the distance set in [step 3 A](#).

 **Note:** Z Stage movement is relative to the current position.

- Press <3> to move the Z Stage up.
- Press <9> to move the Z Stage down.

C. To move the Head:

 **Note:** Each time a number key is depressed, the Head will move the distance set in paragraph, 3 A.

 **Note:** Head movement is relative to the current position.

- Press <4> to move the Head left.
- Press <6> to move the Head right.
- Press <2> to move the Head backward.
- Press <8> to move the Head forward



Chapter 5: Operating Insight

5

This chapter explains the procedure for using the Insight software utilized by the Fortus 360mc/400mc system.

Getting Started with Insight

Starting Insight

To start Insight, select Start>Programs>Stratasys>InsightVxx>Insight.

You can also double-click on the Insight shortcut desktop, if it was installed.

Opening an STL File

To open the file for the part you wish to build:

1. Click File>Open.
2. Select the directory that contains the file you wish to access.
3. Click on the file you wish to select with the left mouse button. (Figure 5-1)

Figure 5-1: Opening an STL File

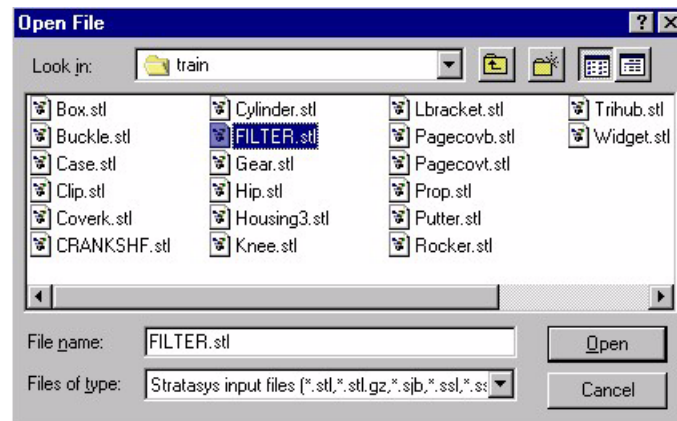

4. Click Open with the left mouse button.
 - You can also open a file by double clicking on the file name with the left mouse button.

Modeler Setup - Insight

Configure Your Modeler

The first step in preprocessing is to configure your modeler.

1. Click the Modeler button  located in the Modeler Setup window (right side of screen) of the Operations Panel. The Configure Modeler dialog box opens. You can also access the Modeler Setup window by selecting Modelers>Setup. (Figure 5-2)

Figure 5-2: Configure the Modeler



2. Select your modeler from the Modeler Field.
3. Select a modeling material (the Support Material field is automatically filled). See "Liquefier Tips" on page 3-9 for modeler/tip compatibility.
4. Select a model tip size (the Support Tip field and the Slice Height field is automatically filled in).

Part Build Parameters

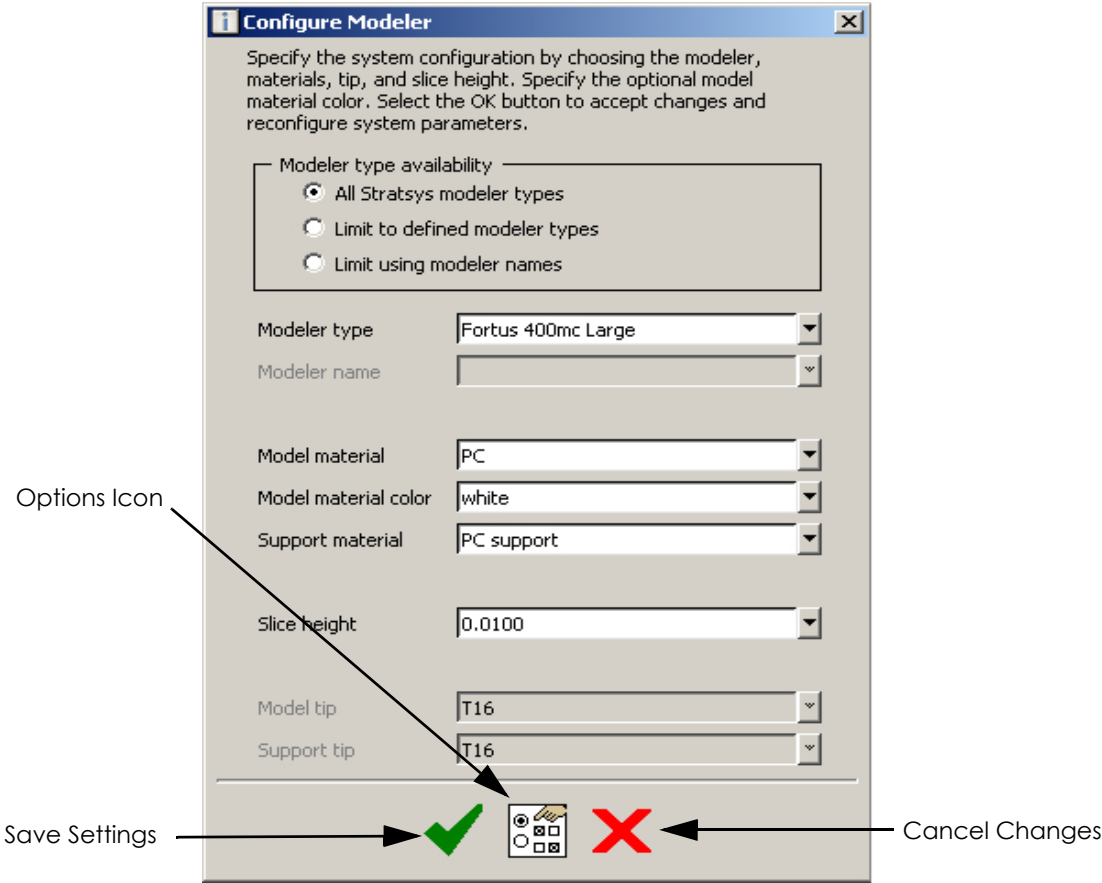
The second step in preprocessing a model is to choose the part build parameters. The part build style will determine the type of fill pattern used to build the part. The part interior style will determine whether the interior of the part is solid or not. The support style will determine the type of supports. (Figure 5-3)

1. Select a part fill style.
 - Typically you will use the perimeter/rasters selection.
2. Select a part interior style.
 - Solid - normal: will be stronger.
 - Sparse: will build faster and use less material.
 - Sparse - double dense: will build with twice the material for a stronger part.
3. Select the Visible surfaces.
 - Fine rasters may improve surface finish while reducing build time on some geometries.
4. Select a Support style.

Figure 5-3: Modeler Setup

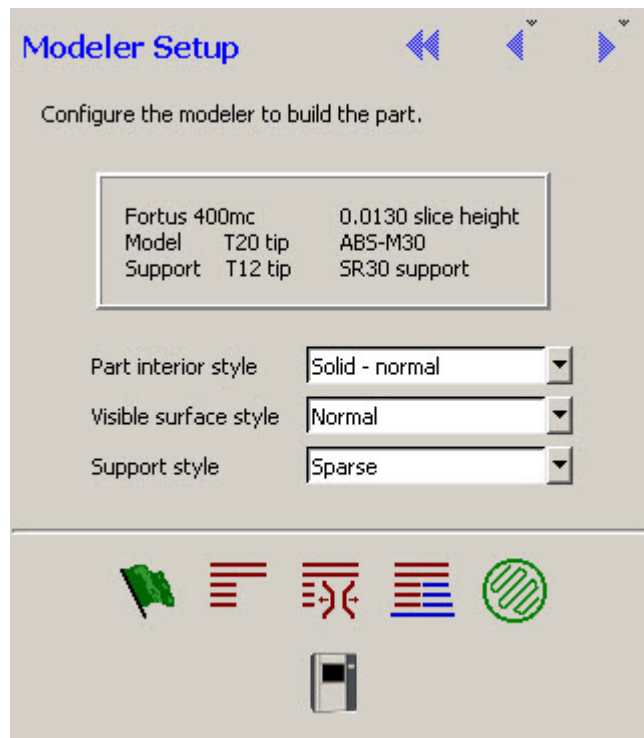

Preparing the Model - Insight

Orienting the Part in the Build Envelope

The modeling build envelope box displayed in Insight indicates the size of the part relative to the build envelope inside the 360mc/400mc.

1. Select the Orient STL button  . The Orient STL menu appears.
2. From the Orient STL menu, click "Rotate". (Figure 5-4)

Figure 5-4: Orient STL Menu

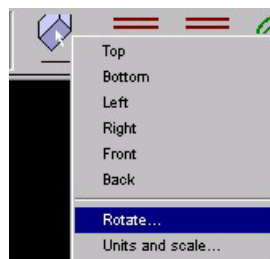

3. Select the rotation parameters in the STL Rotate Operation window. (Figure 5-5)

Figure 5-5: STL Rotate Operation Window

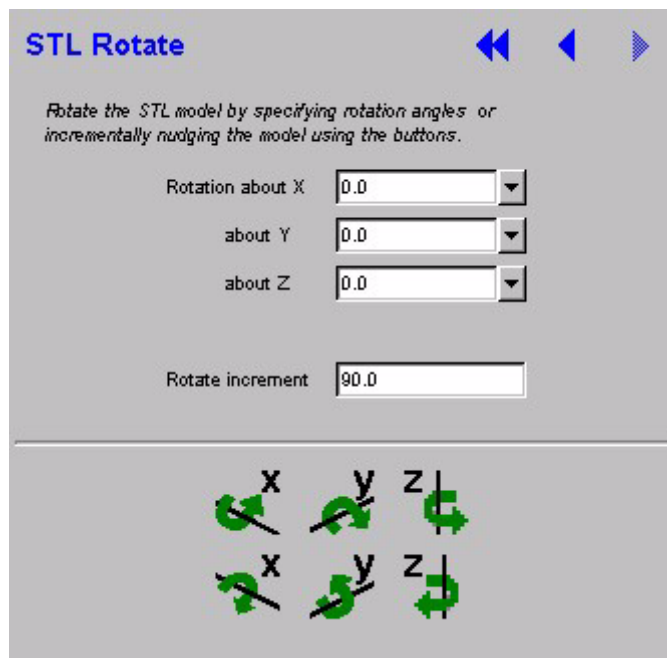

Slicing the Part

Before the part file is sent to the 360mc/400mc, the file must be sliced into the layers that the 360mc/400mc will extrude to construct the part.

Click the Slice button to  create slice curves for the part. Red slice curves are displayed in the graphics window.

Building Supports and a Base for the Part

Most parts require supports and a base to increase part stability while building and optimize the surface finish of parts.

Click on the Create Supports button  to create supports

 **Note:** Depending on part size and your computer's processor speed, Insight may take several minutes to several hours to generate supports.

Saving the Job File

Now that the part has been sliced, and the supports and base have been created, you should save the Job file. The Job file will save the slice, support, and part geometry information.

Click File>Save.

Creating Toolpaths

Before sending the part to the 360mc/400mc, you must create a toolpath for the part. Toolpaths are the paths along which the heads will extrude each layer of model and support material to build the part.

Click the "Toolpath" button  .

Saving the Toolpath (CMB file)

Now that the part file is sliced and ready to send to the 360mc/400mc, it must be saved as a.CMB file, which can be received by the system.

1. Click File>Save As>Toolpath. (Figure 5-6)

Figure 5-6: Saving Toolpath Information

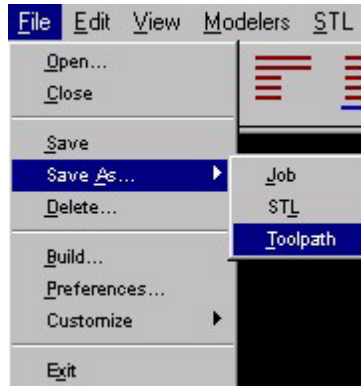

2. Enter the File Name and Directory. Click Save.

Flag Button Shortcut

The Flag button  can be used as an automated shortcut to performing the following procedures:

- Slice the Part
- Build Supports and a Base for the Part
- Save the Job File
- Create Toolpaths
- Save the Toolpath (.CMB file)

Sending a Part to the Modeler

The process of sending a part to a modeler is dependent upon the associated FDM application that you have purchased (FDM Control Center).

 **Note:** FDM Control Center is an application that works with the Insight software to create packs and send part build commands.

 **Note:** For detailed information about using FDM Control Center use the associated Help file within the application.

1. For FDM Control Center:
 - A. Click the Build button from the Insight application.
 - If FDM Control Center is not open, it is automatically started.
 - The part is placed in the Pack View of the FDM Control Center application.
 - B. Click the Build Job button to send the job to the modeler queue.



Chapter 6: Calibration



This chapter describes basic calibration procedure of the Fortus 360mc/400mc system.

Automatic Calibration

After tips are changed the user menu will prompt you to perform a series of automatic calibrations: Auto Z Stage Zero Calibration, Auto Tip-to-Tip Calibration, and XYZ Offset Calibration.



Note: Perform an Autohome XYZ before initiating automatic calibration (Operator Control > Calibrate > AutoHome XYZ).

Operator interaction is not required for Auto Z Stage Zero calibration or the Auto Tip-to-Tip calibration.

XY and Z Tip Offset requires that the operator analyze a calibration part and supply the system with correction values.



Note: If the Automatic Calibration fails, then the same set of calibrations must be run manually - starting with [“Auto Z Stage Zero Calibration - Manual Start”](#) on page 6-8.

Auto Z Stage Zero Calibration

Auto Z Stage Zero Calibration (**Auto z zero** in the display menu) sets the model liquefier tip to the Z zero location on the build sheet. No operator interaction is required.

Auto Z Stage Zero is performed as a part of the tip changing procedure and:

1. If user placement is set to **YES** (see [“Part Build Location”](#) on page 4-31).
 - Before each job build.
2. If user placement is set to **NO**.
 - At power-up.
 - If the user placement setting is changed to **YES**.
 - If the oven temperature was unstable within the preceding six hours of a job build.

- If the previous job was started when the oven temperature was unstable.

Auto Tip-to-Tip Calibration (AutoCal Tip Offset)

Auto Tip-to-Tip Calibration calibrates the tip to tip offsets in the Z direction.

No operator interaction required.

1. The system automatically performs this calibration after the tips are changed or after a material type change.
2. Proper calibration allows the system to toggle material tips and place the current tip at the precise coordinate necessary to continue accurate part build.

XY and Z Tip Offset Calibration

The XY and Z tip offset calibration registers the support tip relative to the model tip.

Operator interaction is required.

1. The system automatically builds the calibration model.
2. Remove the build sheet from the platen and allow it to cool.
3. Determine the XY Offset Adjustment ([Figure 6-1](#) or [Figure 6-2](#))
 - A. View the relationship between the support calibration toolpath and the alignment indicators to determine the X and Y Axis calibration.
 - Use a magnifier.
 - Hold the build sheet up to the light, a light-colored wall, or a light-colored piece of paper.
 - B. Determine where on each axis the support toolpath is most centered between the X-Y alignment path.
 - C. Read the Offset Adjustment Value closest to the centered location for each location.
 - This value represents the adjustment value to be entered into the system - increments of 0.002 of an inch or 0.05 mm.
 - If the value is 0, then the system is calibrated for that axis - an entry is not required.

- D. Enter the Offset Value from the Tip Offset menu (See step 5, "Enter the XY and Z Tip Offset Adjustment Values", on page 6-5).
- E. If an adjustment entry for either axis is required, re-run the calibration model on a clean build sheet (refer to "XY and Z Tip Offset - Manual Start" on page 6-10).
- F. Continue to check and adjust for XY offset until the calibration toolpath is centered at 0 for the X and Y axis.

Figure 6-1: Calibration Model - English Units

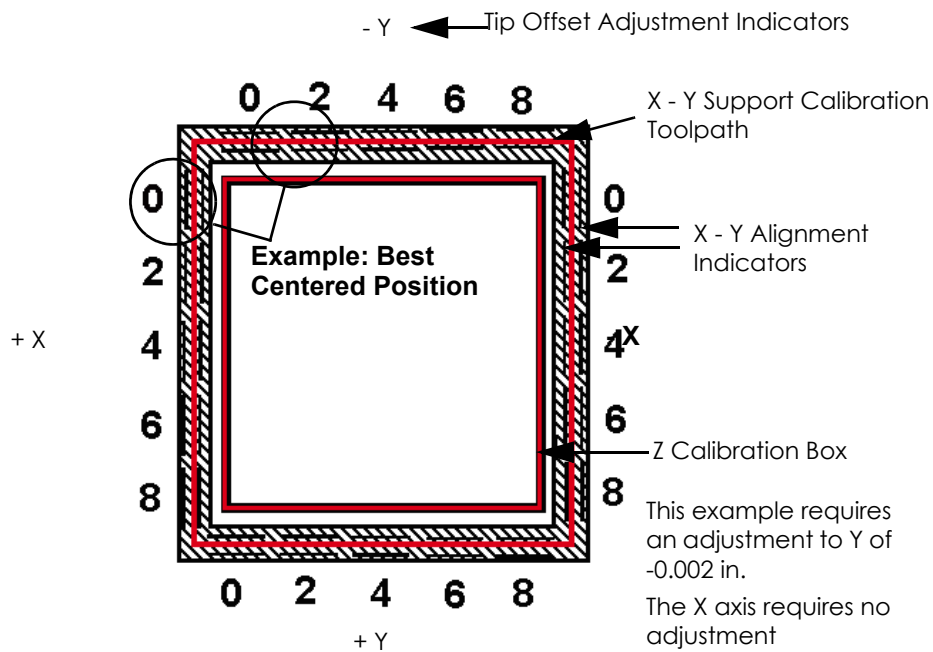
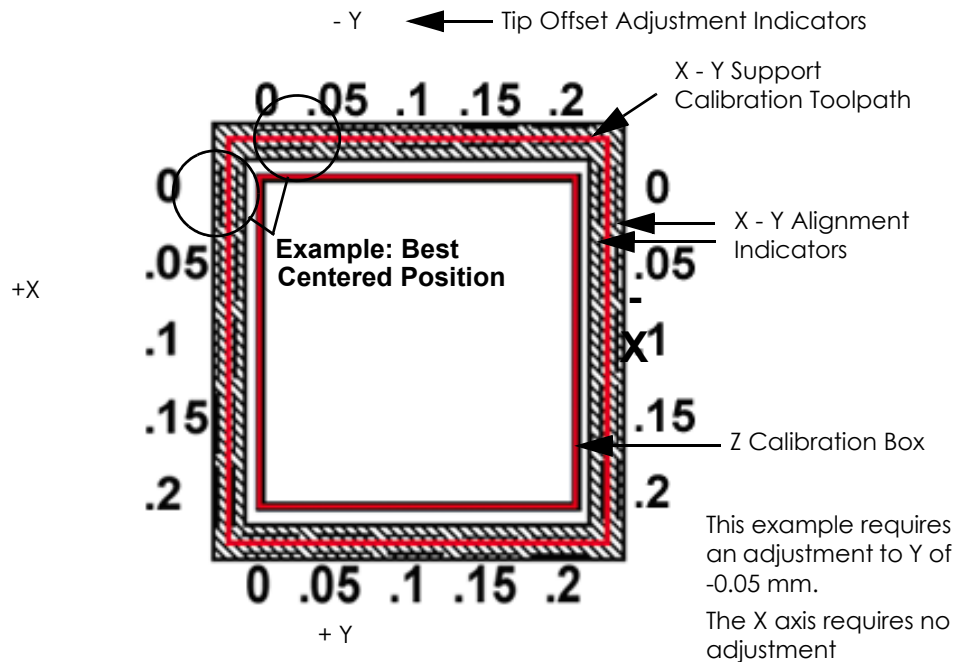

Figure 6-2: Calibration Model - Metric Units



4. Determine the Z Adjustment

Note: Do not measure for Z adjustment until the Calibration Model shows the XY Offset to be less than 0.002 inch (.05 mm) for the X and Y axis.

- A. Peel the Support layer from the Z Calibration box.
- B. Measure the thickness of the Support layer with a caliper or micrometer in the center of all four sides of the calibration box. Record the measured value of the smallest side of the box.
- C. If the measured value is within $\pm 0.0005''$ (0.01 mm) of the Model Tip slice height (see Table 6-1), no adjustment is necessary. Proceed to step E.
- D. If the measured value is outside the $\pm 0.0005''$ (0.01 mm) value, subtract the measured value from the slice height of the Model Tip being used (see Table 6-1).
 - If the Model Tip Slice minus the Measured Support thickness is a positive number, the Z correction is +Z in 0.001 inches.
 - If the Model Tip Slice minus the Measured Support thickness is a negative number, the Z correction is -Z in 0.001 inches.
 - Example: For a T16 Model Tip - slice height of 0.010'' (from Table 6-1); measured thickness of Calibration Box = 0.012''; Calculation $0.010 - 0.012 = -0.002$; Enter 0.002 in the - Z menu option (para 5.D).

- E. Enter the Z Adjustment Value from the Tip Offset menu (see [step 5](#)).
- F. If an adjustment entry is required, re-run the calibration model on a clean build sheet (refer to “[XY and Z Tip Offset - Manual Start](#)” on page 6-10).
- G. Continue to check for Z Calibration until the Support layer matches the Model Tip slice height ± 0.0005 ”.

Table 6-1: Model Tip Slice Heights

Model Tip	Slice Height
T20	0.013"
T16	0.010"
T12	0.007"
T10	0.005"

5. Enter the XY and Z Tip Offset Adjustment Values

- A. From the Main Menu select Operator Control and press Enter.

```
Build Job..          | *Tips: Model T16
>Operator Control.. | *      Support T16
Modeler Status..
Maintenance..
```

- B. Select Calibrate and press Enter.

```
Unlock Door <E>    | Temp Control..
Load/Unload Mtl.. | Move Head/Stage..
Change Tips/Mtl..
>Calibrate..
```

- C. Select Tip Offset Value and press Enter.

```
Set Z Stage Zero.. | Calibration Job <E>
AutoCal Tips <E>
>Tip Offset Value..
AutoHome XYZ <E>
```

- D. Using the arrow keys, select the direction and axis to change.

```
*Delta X:0.0000 Y:0.0000 Z:0.0000
>-X 0.00 <E> | +X 0.00<E>
-Y 0.00 <E> | +Y 0.00<E>
-Z 0.00 <E> | +Z 0.00<E>
```

- E. Enter the adjustment value and press Enter.

- The adjustment value will appear on the top line.

Manual Calibration

Manual Z Stage Zero



Note: If the Auto Z Stage Zero calibration fails, Manual Z Stage Zero Calibration must be performed. This procedure manually sets the model liquefier tip to the Z Zero location.

1. Install a new build sheet and verify that vacuum is present.
2. Run Manual Z Stage Zero Calibration
 - A. From the Main Menu select Operator Control and press Enter.

```
Build Job..          |*Tips: Model T16
>Operator Control.. |*      Support T16
Modeler Status..
Maintenance..
```

- B. Select Calibrate and press Enter.

```
Unlock Door <E>      | Temp Control..
Load/Unload Mtl..   | Move Head/Stage..
Change Tips/Mtl..
>Calibrate..
```

- C. Select Set Z Stage Zero and press Enter.

```
>Set Z Stage Zero.. | Calibration Job <E>
AutoCal Tips <E>
Tip Offset Value..
AutoHome XYZ <E>
```

- D. Select Set Manual Z Zero and press Enter.

```
>Set Manual Z Zero <E>
Modify Current Z Zero..
Auto Z Zero Calibrate <E>
```

- E. The head will begin to move and the display will show:

```
*Positioning.      Please Wait ...
```

- F. After the head completes its move the display will show:

```
>Unlock Door <E>
Set Distance = 0.100 in <E>
Set Z Stage = 0 <E>      (Z: 0.010)
*Move Z Stage +Z<9> -Z<3>
```

- G. Using the operator control panel, raise the platen until the build sheet is almost touching the model liquefier tip.

- Press 3 on the number pad to raise the platen.
- Press 9 on the number pad to lower the platen.
- The distance the platen moves each time a number key is pressed can be adjusted from the **Set Distance** menu option. Press ENTER to toggle through the choices: 0.100, 0.010, and 0.001 inches.

```
Unlock Door <E>
>Set Distance = 0.001 in <E>
Set Z Stage = 0 <E>      (Z: 0.010)
*Move Z Stage +Z<9> -Z<3>
```



Caution: As the platen approaches the tip, set the distance increment to the smallest setting (0.001 inch or .025 mm) to avoid damage to the head and to facilitate setting the Z stage zero.

- The desired distance between the liquefier tip and the build sheet is about .02 inch (.5 mm) or less (without having the tip touch the build sheet).
- Look for the reflection of the tip in the build sheet as the platen approaches the tip. Stop when the reflected tip almost touches the real tip. (Figure 6-3)
- This calibration is used to set a starting point for the automated Z Zero calibration. A close approximation is all that is required.

Figure 6-3: Manual Z Zero Calibration



H. Select Set Z Stage = 0 and press Enter.

- The Z Zero coordinate is read and stored. The head will move to the park position.

```
Unlock Door <E>
Set Distance = 0.001 in <E>
>Set Z Stage = 0 <E>      (Z: 0.010)
*Move Z Stage +Z<9> -Z<3>
```

I. Run the Auto Tip-to-Tip Calibration. See “Auto Tip-to-Tip Calibration (AutoCal Tip Offset)” on page 6-2.

Auto Z Stage Zero Calibration - Manual Start

 **Note:** An Auto Z Stage Zero Calibration must be performed after running “Manual Z Stage Zero” on page 6-6. Use this procedure to manually initiate the calibration.

 **Note:** Perform an Autohome XYZ before Z Stage Zero Calibration (Operator Control > Calibrate > AutoHome XYZ).

1. Make sure a build sheet is installed and verify that vacuum is present.
2. Run the Auto Z Stage Zero Calibration.
 - A. From the Main Menu select Operator Control and press Enter.

```
Build Job..          |*Tips: Model T16
>Operator Control.. |*      Support T16
Modeler Status..
Maintenance..
```

- B. Select Calibrate and press Enter.

```
Unlock Door <E>     | Temp Control..
Load/Unload Mtl..  | Move Head/Stage..
Change Tips/Mtl..
>Calibrate..
```

- C. Select Set Z Stage Zero and press Enter.

```
>Set Z Stage Zero.. | Calibration Job <E>
AutoCal Tips <E>
Tip Offset Value..
AutoHome XYZ <E>
```

- D. Select Auto Z Zero Calibrate and press Enter.

```
Set Manual Z Stage Zero <E>
Modify Current Z Zero..
>Auto Z Zero Calibrate <E>
```

- E. The system performs an Auto Z Stage Zero Calibration. If Auto Z Stage Zero Calibration fails, perform “Manual Z Stage Zero” on page 6-6.

Auto Tip-Tip Calibration (AutoCal Tip Offset) - Manual Start



Note: An Auto Tip-to-Tip Calibration must be performed if the initial automatic calibration fails. Use this procedure to manually initiate the calibration.

“Auto Z Stage Zero Calibration - Manual Start” on page 6-8 must be performed before running the Auto Tip-to-Tip Calibration.

- 1. Run Auto Tip-to-Tip Calibration.
 - A. From the Main Menu select Operator Control and press Enter.

```
Build Job..          |*Tips: Model T16
>Operator Control.. |*      Support T16
Modeler Status..
Maintenance..
```

- B. Select Calibrate and press Enter.

```
Unlock Door <E>      | Temp Control..
Load/Unload MT..    | Move Head/Stage..
Change Tips/MT..
>Calibrate..
```

- C. Select AutoCal Tips and press Enter.

```
Set Z Stage Zero..  | Calibration Job <E>
>AutoCal Tips <E>
Tip Offset Value..
AutoHome XYZ <E>
```

- D. The system automatically calibrates the tips in the Z direction. Calibration time is about 5 minutes. While running, the display will show:

```
* Tip to Tip Calibration Activity *
* Press <ESCAPE> to Abort Calibration *
```

- E. At completion of the calibration, the display will show:

```
* Tip to Tip Calibration Activity *
* Calibration Done: Press <MENU> Key *
```

- 2. Run “XY and Z Tip Offset - Manual Start” on page 6-10.

XY and Z Tip Offset - Manual Start

i **Note:** If the support layer is not centered on the model layer, an XY and Z Offset should be performed.

i **Note:** Perform an “Auto Tip-Tip Calibration (AutoCal Tip Offset) - Manual Start” on page 6-9 before XY and Z Offset.

1. Build the Calibration Model.
 - A. From the Main Menu select Operator Control and press Enter.

```
Build Job..          |*Tips: Model T16
>Operator Control.. |*      Support T16
Modeler Status..
Maintenance..
```

- B. Select Calibrate and press Enter.

```
Unlock Door <E>      | Temp Control..
Load/Unload Mtl..   | Move Head/Stage..
Change Tips/Mtl..
>Calibrate..
```

- C. Select Calibration Job and press Enter.

```
Set Z Stage Zero..  |>Calibration Job <E>
AutoCal Tips <E>
Tip Offset Value..
AutoHome XYZ <E>
```

2. At completion of the calibration model, ‘read’ the model and calibrate the system by following paragraphs 2. through 5. from “XY and Z Tip Offset Calibration” on page 6-2.



Chapter 7: System Maintenance

7

This chapter describes various maintenance items that the user will routinely have to perform on the Fortus 360mc/400mc systems.

Updating Controller Software

The Controller software can be updated by using one of the two methods described below:

Web Method (preferred method)

This method is for customers who have web access.

1. Open the Control Center application and select the **Services** tab and then click **Check for System Updates**.
2. The Stratasys Update Manager window will appear. The application will check to see if the Controller software is current. Follow screen prompts to update the Controller software.

Figure 7-1: Control Center

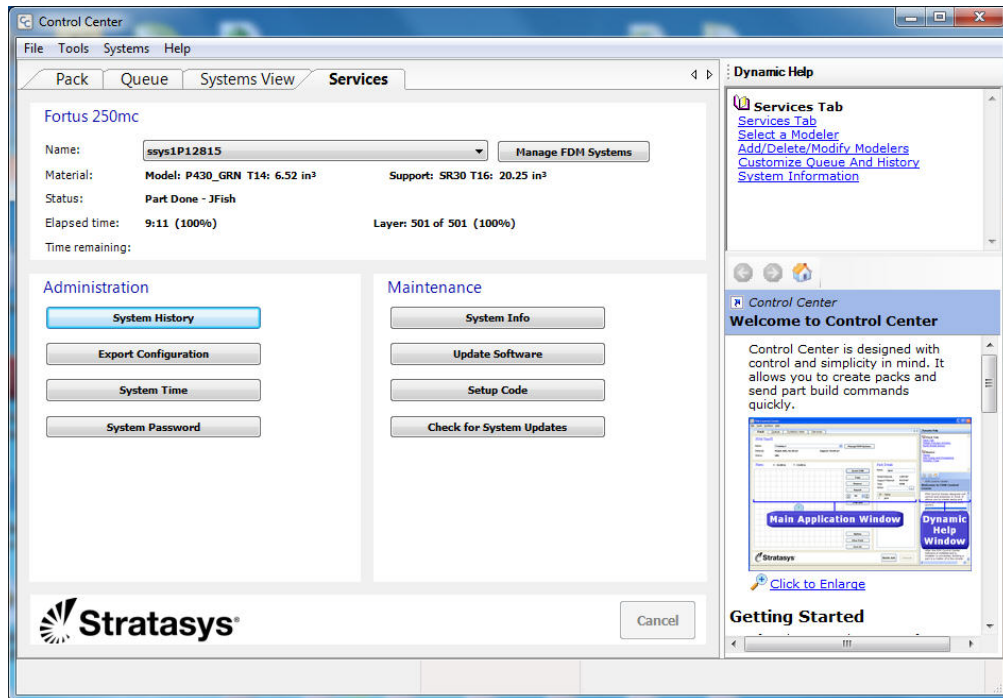

CD Method (alternate method)

This method is for customers who do not have web access. The Controller Software Update CD containing the updated .upg file and must be obtained from Stratasys, Inc.

1. Insert the Controller Software Update CD into the workstation computer.
2. Make sure the system is placed in the receive software upgrade mode. (See [“Placing System in Receive Software Upgrade Mode”](#) on page 7-3.)
3. Open the Control Center application and select the **Services** tab and then click **Update Software**. (See [Figure 7-1](#))
4. Browse to the location of the .upg upgrade file on the Controller Software Update CD.
5. Select the .upg file to be downloaded and then press **Open**. This will send the file to the Fortus 360mc/400mc.
6. When the download is complete, select **Reboot and Install Software Upgrade** and then press **OK** at the Fortus 360mc/400mc system.
7. After the system reboots and the upgrade installation complete, two options will appear; select **Auto Home XYZ**.

Placing System in Receive Software Upgrade Mode

Place the system in software upgrade mode by doing the following:

1. Place the modeler in the Upgrade mode (**Maintenance > Administration > Receive Software Upgrade or Code**).
 - The operator panel will display the following message.

```
>Waiting for Software Upgrade or Code
Press MENU key to Cancel
```

2. The system is now in the receive software upgrade mode.

Maintenance Schedule

Maintenance tasks must be performed on a regular basis in order to maintain optimal system operation. [Table 7-1](#) outlines the general maintenance schedule. Detailed instructions for each task make up the rest of this chapter.



-
-  **Warning:** Always power down and unplug the system before removing any of the access panels.
-
-  **Warning:** Due to the UPS, High voltage is present in the system when the power cord is unplugged.
-
-  **Warning:** Always wear proper heat protective clothing when working inside the oven.
-

Table 7-1: Maintenance Schedule

Daily	Weekly	Quarterly	Maintenance Task
X			"Clean the Platen" on page 7-4
X			"Empty the Purge Waste Bucket" on page 7-4
	X		"Vacuum the Build Envelope" on page 7-5
	X		"Clean/Inspect Tip Wipe Assembly" on page 7-5
		X	"Inspect the Platen O-Ring" on page 7-8
		X	"Clean the Vacuum System In-Line Filter and Jar" on page 7-8
		X	"Clean the Tip Sensor Plunger" on page 7-9

Daily Maintenance

Clean the Platen

The platen is the surface on which the build sheet is placed for modeling. If debris collects on the platen, it can adversely affect the vacuum which secures the build sheet to the platen.

1. Remove the build sheet from the platen.
 - Lift a corner of the build sheet to break the vacuum holding it to the platen.
 - Slide the build sheet from the platen.
2. Carefully remove debris that has fallen into the channels of the platen.
 - Vacuum or use a soft brush.
 - If a brush is used, brush away from the vacuum port in the center of the platen.
 - If debris falls into the vacuum port, it can cause a loss of vacuum, resulting in poor adhesion of the build sheet to the platen during part build.



Note: Do not attempt to remove the vacuum port screen. It is not a customer replaceable item.

3. Inspect the rubber o-ring and replace if cracks are found.

Empty the Purge Waste Bucket

The purge bucket is located inside the canister bay. It catches the material that has been purged or wiped from the liquefiers and liquefier tips. The purge bucket should be emptied daily. (Figure 7-2)

1. Open the canister bay door.
2. Rotate the basket counter-clockwise while pulling the basket from the system.
3. Empty the waste material from the purge waste bucket.
4. Reinstall the basket by inserting it into the opening while rotating the basket clockwise.

Figure 7-2: Purge Waste Bucket



Weekly Maintenance

Vacuum the Build Envelope

Vacuum the build envelope to remove build material waste and dust.

Clean/Inspect Tip Wipe Assembly

You should inspect the tip wipe assembly once a week. Replace parts as necessary when wear is detected.

- The brush and flicker can be replaced as an assembly or the flicker can be replaced individually.
 - The purge ledge assembly is replaced as a single unit.
1. Remove (lift and pull) the upper funnel chute. (Figure 7-3)

Figure 7-3: Chute Cleaning

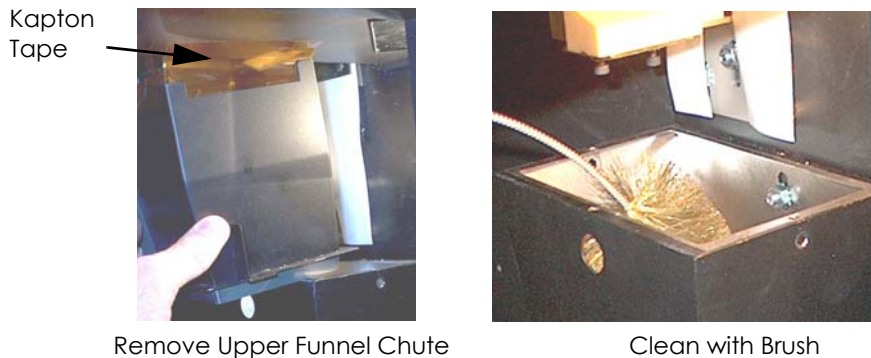

2. Remove the purge ledge assembly - lift to clear locating pins. (Figure 7-5)



Note: There are two versions of the purge ledge available; one for PPSF (labeled "PPSF") and one for all other materials.

3. Remove the 2 flicker/brush assemblies - lift to clear locating pins. (Figure 7-5)
4. Use cleaning brush (in system start-up kit) to remove debris from inside of the chute (including removed top).
5. Clean the purge ledge assembly and the flicker/brush assemblies.
6. Clean and inspect the surface around the locating pins - make sure that the purge ledge and flicker/brush assemblies can sit flush on the surface.
7. Inspect the Kapton tape around the upper funnel chute. Replace the Kapton tape if wear or tears are evident.

- The Kapton tape is secured to the upper funnel chute with self-adhesive material. To replace the tape, peel the tape from the chute.
 - Clean the area around the top of the upper funnel chute with Isopropyl alcohol and a clean, lint-free cloth.
 - Peel the backing material from the new Kapton tape and carefully position the shield in place on the upper funnel chute - the top edge of the adhesive area should be even with the top of the chute.
 - Press the Kapton tape in place to secure.
8. Inspect the purge ledge assembly (Figure 7-5).
 - The purge surface should be free from pock marks or surface irregularities.
 - Install a new purge ledge assembly if necessary.
 9. Inspect the flicker/brush assemblies.
 - The top edge of the flicker should be straight. Replace the flicker if it is notched or bent - a small amount of wear is acceptable. (Figure 7-4) The flicker can be replaced individually if the brush is acceptable for reuse.

Figure 7-4: Inspecting the Flickers



- The brush bristles must not show evidence of wear from the tip - no notches in the bristle pattern.
 - Frayed bristles are acceptable as long as the top edge is even across all of the bristles.
 - Replace the flicker/brush assembly if the brush does not meet inspection requirements.
10. Install the flicker/brush assemblies - place over locating pins.
 11. Install the purge curtain and purge ledge assembly - place over locating pins.
 12. Install the upper funnel chute.

Figure 7-5: Tip Wipe Assembly

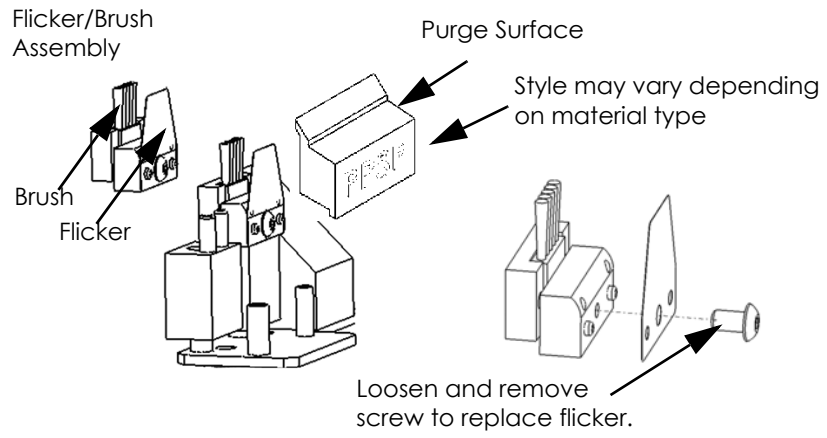

Quarterly Maintenance

Inspect the Platen O-Ring

Check the platen o-ring for cracks, cuts, nicks, etc. - none allowed. Replace the o-ring as necessary.

1. Remove the o-ring from the groove around the platen.
 - No special tools or techniques are required. The o-ring is held in place by contact pressure.
2. Clean dirt and debris from the platen groove.
3. Install new o-ring in groove.
 - Use care so as to not damage o-ring during installation.
 - Do not twist the o-ring during installation.

Clean the Vacuum System In-Line Filter and Jar

1. Power down the system, see [“Powering Down the System”](#) on page 4-4.
2. Remove the lower, right side panel, see [“Right Side Door - Lower”](#) on page 3-4.
3. Unscrew the vacuum filter jar. ([Figure 7-6](#))
4. Remove debris and dirt from the filter jar - use a clean, lint-free cloth.
5. Replace the filter.
6. Reinstall the vacuum filter jar.
7. Reinstall the lower, right side panel.

Figure 7-6: Vacuum Filter Location

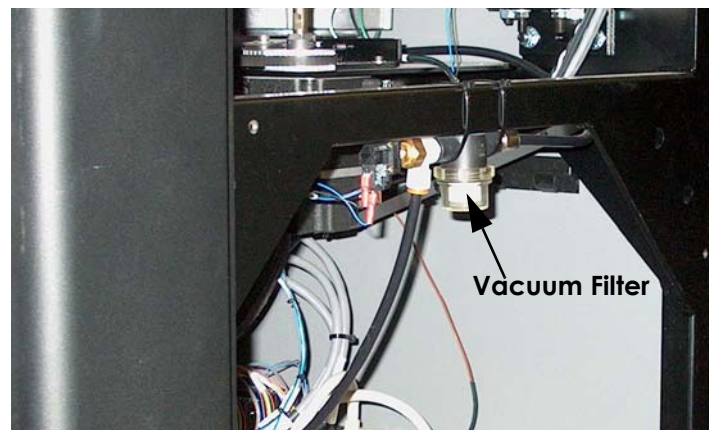

Clean the Tip Sensor Plunger

1. Remove the plunger - gently pull up and out. (Figure 7-7)
2. Remove material residue on the top of the plunger with a razor blade.
3. Replace the plunger in the sensor bracket - make sure the flat surface is up.

Figure 7-7: Tip Sensor

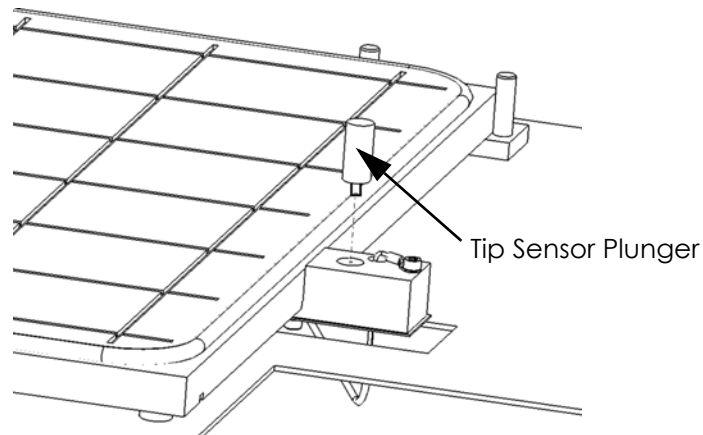

As Needed Maintenance

Upgrading Software or Entering a System Code

Upgrades to controller software and system codes are uploaded to the system.

i **Note:** To upgrade system controller software, or to enter a system change code, access to an Insight workstation is required.

An Insight workstation with Internet access will check for controller software upgrades, notify you of upgrade availability, and walk you through the procedure to download the upgrade to the Insight workstation.

System change codes are obtained from your Stratasys Representative.

1. Verify that the system is idle.
2. Place the system in the Receive Software Upgrade or Code mode.
 - A. From the Main Menu select **Maintenance** and press ENTER.

```
Build Job..      | *Tips: Model T16
Operator Control.. | *   Support T16
Modeler Status..
>Maintenance..
```

- B. Select **Administration** and press ENTER.

```
Modeler Default..  
>Administration..  
Reboot system..
```

- C. Select **Receive Software Upgrade or Code** and press ENTER.
The system is now ready to receive the new software upgrade or code from the Insight workstation.

```
Network Configuration..  
>Receive Software Upgrade or Code..<E>  
Field Service.. password:
```

```
>Waiting for Software Upgrade or Code  
Press MENU key to Cancel
```

3. From the Insight workstation:
- A. Open the Insight FDM CC application.
 - B. From the Name: drop-down list, select your the 360mc/400mc machine.
 - a. Access the Services Tab.
 - From FDM CC: click the Services Tab.
 - C. Use the appropriate button ('Update Software', 'Setup Code') to upload the change to the modeler.
 - D. If updating software, navigate to the location of the upgrade file.
 - If using CD, upgrade files (UPG) are found in the CD directory.
 - If downloaded from internet, upgrade files are located in the 'Stratasys' folder on the workstation.
 - E. Select and confirm the UPG file to upload.
 - a. When the upload is complete, from the modeler, select "Reboot and Install Software Upgrade <E>" and press ENTER.



Note: To cancel the upgrade, press ESCAPE on your keyboard.

- F. The system applies the change and reboots.
 - The system is now in its normal power up state.
 - Log files and calibration files are preserved by the upgrade installation process.

Platen Flatness Diagnostic

1. If a part fails to adhere to the build sheet or the tip digs into the build sheet, the platen may not be flat. Five measurements are taken for the diagnostic, one in each corner of the platen and one in the center of the platen.
2. To check the platen flatness:
 - A. Install a new build sheet.
 - B. Verify that the vacuum gauge reads -15 Hg or higher (more negative).
 - C. Select **Maintenance>Measure Flatness**. The following screen is displayed. The diagnostic is also stored in the job log in case it is necessary for Customer Support to view the diagnostic.

```
*           Z Height Measurements           *
UL:  -0.0050                               UR:  0.0020
                Center:  0.0000
LL:  0.0120                               LR:  0.0090
```

- D. Verify that all numbers are within $\pm 0.015''$.

Clean Exterior Surface of System

Exterior surfaces of the system may be cleaned using a lightly damp cotton cloth. Clean the oven door glass with a cleaner that does not contain ammonia.

Clean the Liquefier Tips

The system automatically cleans the tips before and during each part build - using the tip cleaning assembly. However, occasionally, material may build up on the tips that cannot be removed during the auto-cleaning process. Remove excess material manually using a brass, wooden-handled brush (included in the Startup Kit).

Replace an Interior Lamp

1. The interior lamps, located inside the oven, will periodically burn out and require replacement. Use the following steps to replace a lamp:
 - A. Power down the system and allow the oven to cool.



Warning: If the system is not completely powered down, High voltage AC is still present in the system. There is a chance that changing a lamp may expose you to this voltage. All AC line voltage is eliminated by powering down the system in the manner described.



Caution: DO NOT continue until the six-minute cooling cycle has completed. This can be verified by examining the UPS status LEDs through the back panel grill. DO NOT attempt to replace the light bulbs if ANY UPS LEDs are still lit!

- B. Turn the main circuit breaker and the UPS power switch off.
- C. Remove the burned out bulb, and install the replacement bulb.
- D. Turn on the Main Circuit breaker, the UPS switch.
- E. Power up the system and verify the lamps are operating.



Chapter 8: Troubleshooting



This chapter describes basic troubleshooting that can be done by the user to correct basic problems with the Fortus 360mc/400mc systems.

Getting Help

If you have problems with your system or materials, that are not covered in this user guide or in the T-Class Quick Reference Card, or if you need to order replacement parts, please contact Customer Support by using one of the following methods:

- Call Customer Support: 800.801.6491 (7:00 a.m. to 5:00 p.m. C.T.)
- E-mail us at: support@stratasys.com
- Write to:

Stratasys, Inc.
Customer Support
7665 Commerce Way
Eden Prairie, MN 55344 USA

Before calling for service or supplies, always have the following information ready:

- Your system's software version
- Your system's serial number
- Access to your Insight workstation (to provide a diagnostic file if necessary).

Finding a Remedy

Condition	Possible Cause	Remedy
Canister will not load	Anti-rotation plug not removed from canister.	Remove plug.
	Rubber thumbwheel insert not removed from thumbwheel door.	Remove thumbwheel insert.
	Empty canister (zero volume)	Replace canister.
	Filament stuck in canister.	Remove canister from system and pull out about eight feet (two meters) of material out. Ensure filament pulls out freely.
	Canister drive block not fully lowered onto canister.	Reset drive block onto canister.
	Wrong tip size selected on operator display.	Verify correct tip size on display. See "Liquefier Tips" on page 3-9 .
	Canister smartspool circuit failed.	View Filament Status from operator display. If the status reads None or is blank, replace the canister.
	Broken or bent pogo pin.	Remove canister from bay and check pogo pins on underside of the canister drive block. Replace any bent or broken pogo pins.
	Filament does not reach head (load time-out reached).	Install a new canister. If this fails, call Customer Support.

Condition	Possible Cause	Remedy
Loss of extrusion (Head will not extrude material)	Filament stuck in canister	Remove canister from system and pull out about 8 feet (2 meters) of material out. Ensure filament pulls out freely.
	Canister drive is too slow	Verify that load time from the canister to the head switch is less than 2:00 min.
	Material not extruding on first two layers of model base	Verify that material purges by performing a load. Perform Platen Level Diagnostic. Verify that all numbers are less than +/- 0.015". See " Platen Flatness Diagnostic " on page 7-11.
	Plugged Tips	Verify that the size of installed tip matches with tip size indicated on operator display. Verify that tip life has not exceeded maximum tip odometer. Verify tips were installed correctly. Verify that material purges by performing a load. Replace tip with new tip and recalibrate.
	System not calibrated	Verify that material purges by performing a load. Perform Auto Z Stage Zero and AutoCal Tips.
	Low vacuum caused build sheet to shift and may have plugged tip.	See Low Vacuum in this table.

Condition	Possible Cause	Remedy
Low Vacuum (Vacuum gauge does not read -15 or greater)	The build sheet is not properly installed.	Move the sheet until it overlaps the platen equally on all sides.
	There is filament debris on the platen.	Remove the build sheet and clean the top surface of the platen.
	A small piece of material may have been sucked into the vacuum line.	For on board air only, check vacuum pump inlet and verify that it is free of debris. Empty the vacuum system filter jars.
	The vacuum screen may be plugged.	Clean the vacuum screen. Do NOT remove the screen - it is not a customer replaceable item.
	The exhaust port on the vacuum pump may be clogged, or the vacuum pump may require replacing.	Call Customer Support.
	Rubber O-ring is twisted or needs replacing.	Remove ring and inspect for cracks. Replace if cracks are found or reinstall insuring ring is not twisted. Replace ring if problems persist.
Air pressure is low	This scenario is not operator adjustable.	Contact Customer Support for further instruction.
Support material is difficult to remove from part	Support material is imbedded in the vertical surfaces of the part.	Adjust the tip-to-tip calibration.
Model material not sticking to build sheet	Platen is out of level.	Perform Platen Level Diagnostic. Verify that all numbers are less than +/- 0.015". See "Platen Flatness Diagnostic" on page 7-11.
Model material surface finish is poor on downward facing surfaces Support material removes too easily	The tip to tip calibration is not set correctly.	Repeat tip to tip calibration.
Material is oozing	Dryer failure.	Call Customer Support.
	Moisture in the canister.	Call Customer Support.

Condition	Possible Cause	Remedy
Oven not maintaining temperatures	Heater failure	Call Customer Support.
	Oven door open.	Close the oven door; the heater turns off while the door is open.
	Oven door not sealing with oven fascia panel.	Call Customer Support.
<p>Information Available If a Job Fails While Building If a job fails, you can determine the last layer built. From the system interface choose: Modeler Status > Machine State > Machine Status</p>		



Appendix A: UI Menu Structure

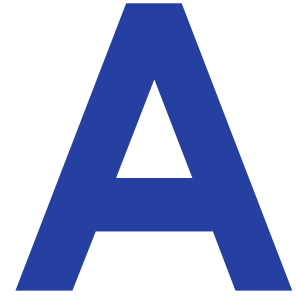

Main Menu

1 - Main Menu

Build Job..	*Tips: Model T16
>Operator Control..	* Support T16
Modeler Status..	
Maintenance..	

2 - Build Job..

>Build Next Job: "Name of Job" <E>
Build Last Job: "Name of Job" <E>
Show Job Queue.. (6 Jobs)
Show Sample Job Queue.. (all jobs)

3 - Show Job Queue..

>1) "Name of Job" <E> 5:23 hr
2) "Name of Job" <E> 121:45 hr
3) "Name of Job" <E> 15:12 hr

3 - Show Sample Job Queue..

>1) "Name of Sample Job" <E> 5:23 hr
2) "Name of Sample Job" <E> 121:45 hr
3) "Name of Sample Job" <E> 15:12 hr

1 - Main Menu

Build Job..	*Tips: Model T16
>Operator Control..	* Support T16
Modeler Status..	
Maintenance..	

2 - Operator Control

Unlock Door <E>	Calibrate..
>Load/Unload Mtl..	Temp Control..
Change Tips/Mtl..	Move Head/Stage..

3 - Load/Unload Mtl..

>Load Material..
Unload Material..
Material Status..
Unplug Tips..

4 - Load Material..

>M1L:PPSF92.0 in3 (Ready)
M2L:PC91.6 in3<E>(Loaded)
S1L:PC_S92.3 in3<E>(Ready)
S2L:PPSF_S41.4 in3<E>(Ready)

4 - Unload Material..

M1L:PPSF92.0 in3(Ready)
>M2L:PC91.6 in3<E>(Loaded)
S1L:PC_S92.3 in3(Ready)
S2L:PPSF_S41.4 in3(Ready)

4 - Material Status..

```
** Model 1:PC 92.3 in3 (Ready)
* Model 2:PC 67.1 in3 (Loaded)
** Support 1:PC_S 92.3 in3 (Loaded)
* Support 2:PC_S 0.0 in3 (Empty)1
```

4 - Unplug Tips..

```
***** Head Purge Buttons Activated *****
MODEL (1) Support (2)
** Model Warming to 145° C (now 85° C) **
** Supp Warming to 145° C (now 85° C) **
```

3 - Change Tips/Matl..

```
>Unload Model and Support.. <E>
*2. Insert new canisters (if required)
*3. Install tips
Select Materials/Tips..
```

4 - Select Material/Tips..

```
*M PC [R | * | * | R]PC_S S*
>Review Materials to Load..
Select Tips <E> T12 T12
Reset Tip Odometers..
```

5 - Review Materials to Load..

```
>M1L:PPSF 92.0 in3 <E> (Ready)
M2L:PC 91.6 in3 <E> (*Ready)
S1L:PC_S 92.3 in3 <E> (*Ready)
S2L:PPSF_S 41.4 in3 <E> (None.)
```

5 - Reset Tip Odometers.. (if user placement on)

>Reset Model in3 <E> 633.5 ()
Reset Supp. in3 <E> 182.7 ()
Select Calibration Part Position..
Unlock Door <E>

5 - Reset Tip Odometers.. (if user placement off)

Reset Model in3 <E> 633.5 ()
Reset Supp. in3 <E> 182.7 ()
>Load and Calibrate..
Unlock Door <E>

6 - Select Calibration Part Position.. (if user placement on)

Locate Part Start..
Demo Bounding Box <E>
>Load and Calibrate..

6 - The following screens display automatically:

* Waiting h:mm to stabilize
** Actual 100°C Setpoint: 225°C
>Unlock Door <E> | Vacuum On
Calibrate Immediately <E>

* Tip to Tip Calibration Activity *
Please Wait...

*Job: Calibration Job (Building)
*Build Time: 0:04 hr of 0:08 hr
*PC 0.1 in3 PC_S 0.0
>Modeler Status.. 0.010 of 0.050 in

3 - Calibrate..

```
>Set Z Stage Zero..      | Calibration Job <E>
AutoCal Tips <E>
Tip Offset Value..
AutoHome XYZ <E>
```

4 - Set Z Stage Zero..

```
>Set Manual Z Stage Zero<E>..
Modify Current Z Zero..
Auto Z Zero Calibrate <E>
```

5 - Set Manual Z Stage Zero..

```
*Positioning.    Please Wait...
```

```
Unlock Door <E>
Set Distance= 0.100 in <E>
>Set Z Stage= 0 <E> (Z: 0.010)
*Move Z Stage: +Z<9> -Z<3>
```

5 - Modify Current Z Zero..

```
* Modify Current Z Zero    Z: 16.250
>+ 0.00 <E>
- 0.00 <E>
```

4 - Tip Offset Value..

```
*Delta X:0.0000 Y:0.0000 Z:0.0000
>-X 0.00 <E> | +X 0.00<E>
-Y 0.00 <E> | +Y 0.00<E>
-Z 0.00 <E> | +Z 0.00<E>
```

3 - Temp Control..

Set Oven to Build Temp: 145° C <E>
Cool Down Oven to: 85° C <E>
>Auto Cool Oven: OFF <E>

3 - Move Head/Stage..

Move Head to Service Location <E>
Move Head to Center-Front Location<E>
Move Z Stage to Bottom <E>
>Move Relative..

4 - Move Relative..

>Set Distance= 0.100 in <E>
*Move Head: +X <6> -X<4> +Y <2> -Y <8>
*Move Z Stage: +Z <9> -Z <3>
*Current: X: 0.000 Y: 0.000 Z: 0.000

1 - Main Menu

Build Job.. |*Tips: Model T16
Operator Control.. |* Support T16
>Modeler Status..
Maintenance..

2 - Modeler Status..

>Temperatures..
Material Status..
Tip Status..
Machine State

3 - Temperatures..

* Current Setpoint
* Oven:78° C / 80° C
* Model:198° C / 200° C
* Support:301° C / 300° C

3 - Material Status..

```
** Model 1: PC 56.4 in3 (Loaded)
* Model 2:      in3 (None)
** Support 1: PC_S 21.4 in3 (Loaded)
* Support 2:      in3 (None)
```

3 - Tip Status..

```
* Mat'l amount
*Model tip : 0.0 in3
*Support tip : 0.0 in3
*Tips: Model <T16> Support <T16>..
```

3 - Machine State..

```
Sensor States..
System Status..
UPS Status..
>400mc v2.x.x
```

4 - Sensor States..

```
Door State: -Closed-
Hood State: -Closed-
Sense Head Switch1: -OFF-
Sense Head Switch2: -OFF-
Filament at Model Head: -NOT Sensed-
Filament at Support Head: -NOT Sensed-
Tip Sensor: -OFF-
Vacuum Switch: -Vacuum (no)
Model 1 Fil: Motor OFF:Rev Filament
Model 2 Fil: Motor OFF:Rev NO Filament
Supp 1 Fil: Motor OFF:Rev Filament
Supp 2 Fil: Motor OFF:Rev Filament
```

4 - System Status..

```
Last Built Layer = XX
Serial Number = XXX
UPS Type = Invensys or Best Power
SERVO ID = XX
HEADBOARD FIRMWARE = X.X
MIO BOARD FIRMWARE = X.X
AC BOARD FIRMWARE = X.X
CANISTER 0 FIRMWARE =X.X
CANISTER 1 FIRMWARE =X.X
CANISTER 2 FIRMWARE =X.X
CANISTER 3 FIRMWARE =X.X
Materials =
Envelope Size =
Device= "eth0"
IPADDR= "xxx.xxx.xxx.xxx"
NetMask= "xxx.xxx.x.x"
OnBoot= "yes"
BootProto= "none"
UPNP = "Enabled"
Networking= yes
Forward_IPV4= "no"
Hostname= "400mc"
DomainName=
Gateway= "xxx.xxx.xxx.xxx"
GatewayDev= "eth0"
```

4 - UPS Status..

```
Status=(x) IPV=230.00   IPFV=230
OPV=230.00  OPLOAD=32.00  OPFreq=60.00
BattV=28.00  UPSTemp=48.2  Update=60.00
CPUTemp=N/A  Ident=BestPowerFortres or
              Invensys Powerware 5
```

1 - Main Menu

Build Job.. |*Tips: Model T16
Operator Control.. |* Support T16
Modeler Status..
>Maintenance..

2 - Maintenance..

>Modeler Default..
Administration..
Reboot Machine..
Procedures..

3 - Modeler Default..

>Display Units = in (Inches) <E>
User Placement on Platen: NO

3 - Administration..

>Network Configuration..
Receive Software Upgrade or Code..
Field Service.. password:

4 - Network Configuration..

Dynamic IP: YES <E>
UpnP: ON <E>
*Configure Static Network Address

5 - Configure Static Network Address (Dynamic IP = NO)

```
>IP   : [172.16.70.10]
MASK:  (.none found)
GW    : [172.16.100.1]
```

4 - Receive Software Upgrade or Code..

```
>Waiting for Software Upgrade or Code
Press MENU key to Cancel
```

3 - Reboot Machine..

```
!! Hit the 1 key to Reboot Now
!! or press <MENU> key
```

3 - Procedures..

```
Measure Flatness <E>!
Change Head..
```

4 - Change Head

```
*M ABS-M30 [L | L ] SR20 S
Unload Model and Support
Unlock Door <E>
>Turn Off Head Power
```

4 - Menu after head power is turned Off

*OK to Install New Head

Reboot System <E>

