

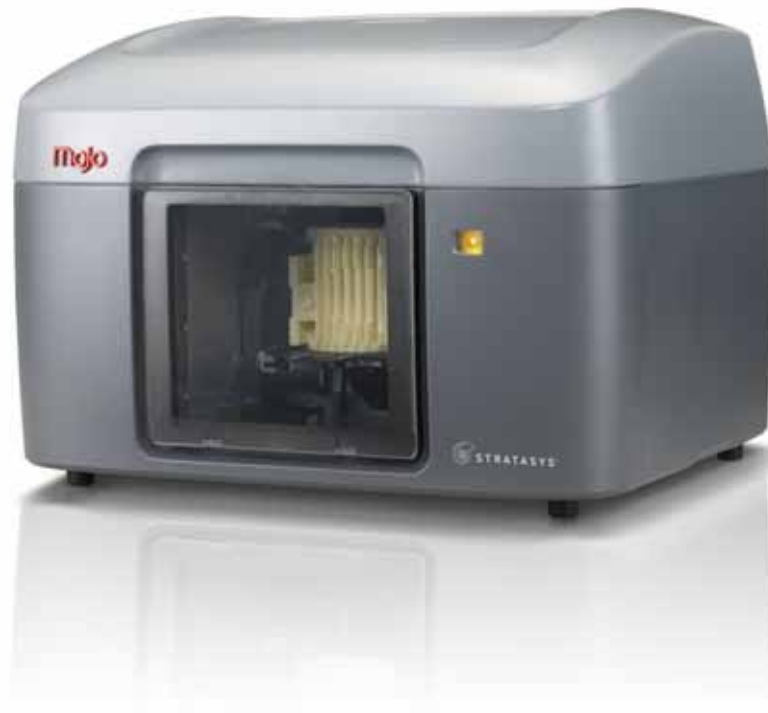

User Guide



Notice

The only warranties for Stratasys products and services are set forth in the express warranty statement accompanying such products and services. Nothing herein should be construed as constituting an additional warranty. Stratasys shall not be liable for technical or editorial errors or omissions contained herein.

© 2013 Stratasys Inc. All rights reserved. uPrint, Dimension, Dimension BST, Dimension SST, WaveWash, Catalyst, and Ecoworks are registered trademarks of Stratasys Inc. Mojo, uPrint Plus, uPrint SE, uPrint SE Plus, Print Pack, *ABSplus*, Catalyst EX, FDM, Fused Deposition Modeling, and QuickPack are trademarks of Stratasys, Inc. All other trademarks are the property of their respective owners, and Stratasys assumes no responsibility with regard to the selection, performance, or use of these non-Stratasys products. Product specifications are subject to change without notice.

Table of Contents

1	Introduction	1
	How to use this guide	1
	Learn more!	1
	Safety precautions	2
2	Overview	3
3	Setup	9
	Connecting the system	9
	Connecting the power	9
	Installing software	10
4	Operation	13
	LED display	13
	Printer status icons	14
	Print Wizard/3D Printer software overview	15
	Installing a modeling base	16
	Processing your STL file for printing	17
	Control Panel Drop-Down Menu	32
	Removing a completed part	35
	Emptying the purge buckets	36
	Removing support material	36
	Powering off	36
	Removing the QuickPack Print Engine	37
	Storing QuickPack Print Engine	38
	Replacing the QuickPack Print Engine	39
	Removing and installing tip wipes	44
5	Maintenance	45
	Daily	45
	As needed	45
6	Troubleshooting	46
	General	46
	Cycling power	46
	Cleaning head tips	46
	Loss of extrusion	46
	Extrusion verification	47

Exporting printer file	47
Troubleshooting	48
Warning/fault codes	49
Fault code chart	49
Warning code chart	50
Error code chart	51
7 Support.....	53
Registration	53
Customer support	53
8 Recycling	54
9 Printer Specifications	55
Physical specifications.....	55
Facility specifications	55
Computer specifications	56
Power specifications	56
Environmental specifications	56
Acoustic specifications	56
10 Supplemental Information.....	57
Stratasys limited warranty statement	57
Declaration of conformity	59
Regulatory and environmental information.....	60
11 Glossary	62

1 Introduction

Congratulations on purchasing a Mojo 3D Printer.

Your Mojo 3D Printer provides a complete solution to your 3D printing needs with an innovative combination of proprietary hardware, software and material technology. Process your designs with the Mojo Print Wizard and begin printing your models in strong, durable *ABSplus* material in just a matter of minutes.

Welcome to the magic of 3D printing!

How to use this guide

This User Guide is laid out in easy to follow sections for Operation, Maintenance, and Troubleshooting. Read each section carefully so that you will get the best performance from your printer.

Learn more!

This User Guide provides information on the following topics:

- Troubleshooting information
- Important safety notices and regulatory information
- Detailed user instructions

You can also find more information at: www.Stratasys.com

Safety precautions

The following precautions ensure the proper use of the printer and prevent the printer from being damaged. Follow these precautions at all times.

- Use the power supply voltage specified on the nameplate. Avoid overloading the printer's electrical outlet with multiple devices.
- Ensure the printer is well-grounded. Failure to ground the printer may result in electrical shock, fire and susceptibility to electromagnetic interference.
- Before disassembling or repairing the printer yourself, contact your local Service Representative. See the Support section in the User Guide.
- Use only the power cord supplied with the printer. Do not damage, cut or repair the power cord. A damaged power cord has risk of fire and electric shock. Replace a damaged power cord with an approved power cord.
- Do not allow metal or liquids to touch the internal parts of the printer. Doing so may cause damage, fire, electric shock or other serious hazards.
- Power off the printer and disconnect the power cord from the power outlet in any of the following cases:
 - If there is smoke or an unusual smell coming from the printer.
 - If the printer is making an unusual noise not heard during normal operation.
 - A piece of metal or a liquid touches the internal parts of the printer.
 - During an electrical (thunder/lightning) storm.
 - During a power failure.

2 Overview

The Mojo system builds models from CAD STL files that are sent to the system using a USB cable from a dedicated host computer. The printer builds three-dimensional parts by extruding *ABSplus* model material and SR-30 support material through two computer-controlled print heads, producing high quality parts that are ready to use immediately after completion.

The Mojo system consists of two consumable QuickPack Print Engines. One QuickPack Print Engine contains *ABSplus* model material and the other QuickPack Print Engine contains SR-30 support material.

Print Wizard is the preprocessing software that runs on Windows 7 or Windows 8 platforms.

Mojo builds a maximum part size of 127 x 127 x 127 mm (5 x 5 x 5 in.). Each QuickPack Print Engine contains 1311 cm³ (80 in³) of material and the extrusion head.

Power Requirements: 100-240V~, 6-3A, 50/60Hz

Figure 1 Front and right side view of printer

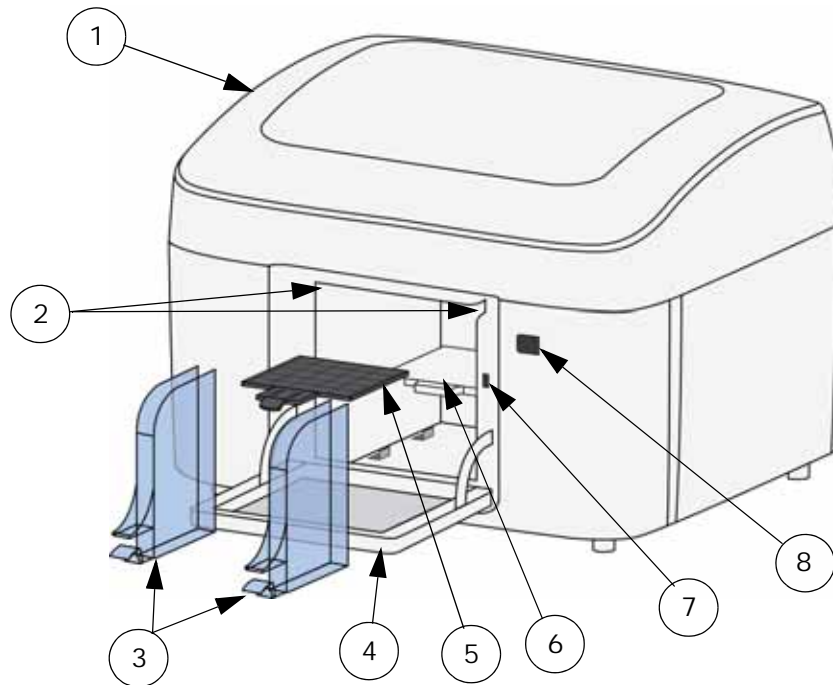

-
- | | |
|---|-------|
| 1 | Cover |
|---|-------|
-
- | | |
|---|---------------------|
| 2 | Tip wipe assemblies |
|---|---------------------|
-
- | | |
|---|---------------|
| 3 | Purge buckets |
|---|---------------|
-
- | | |
|---|------|
| 4 | Door |
|---|------|
-
- | | |
|---|---------------|
| 5 | Modeling base |
|---|---------------|
-
- | | |
|---|--------|
| 6 | Platen |
|---|--------|
-
- | | |
|---|-------------|
| 7 | Door sensor |
|---|-------------|
-
- | | |
|---|-------------|
| 8 | LED display |
|---|-------------|
-

Figure 2 Top view of printer

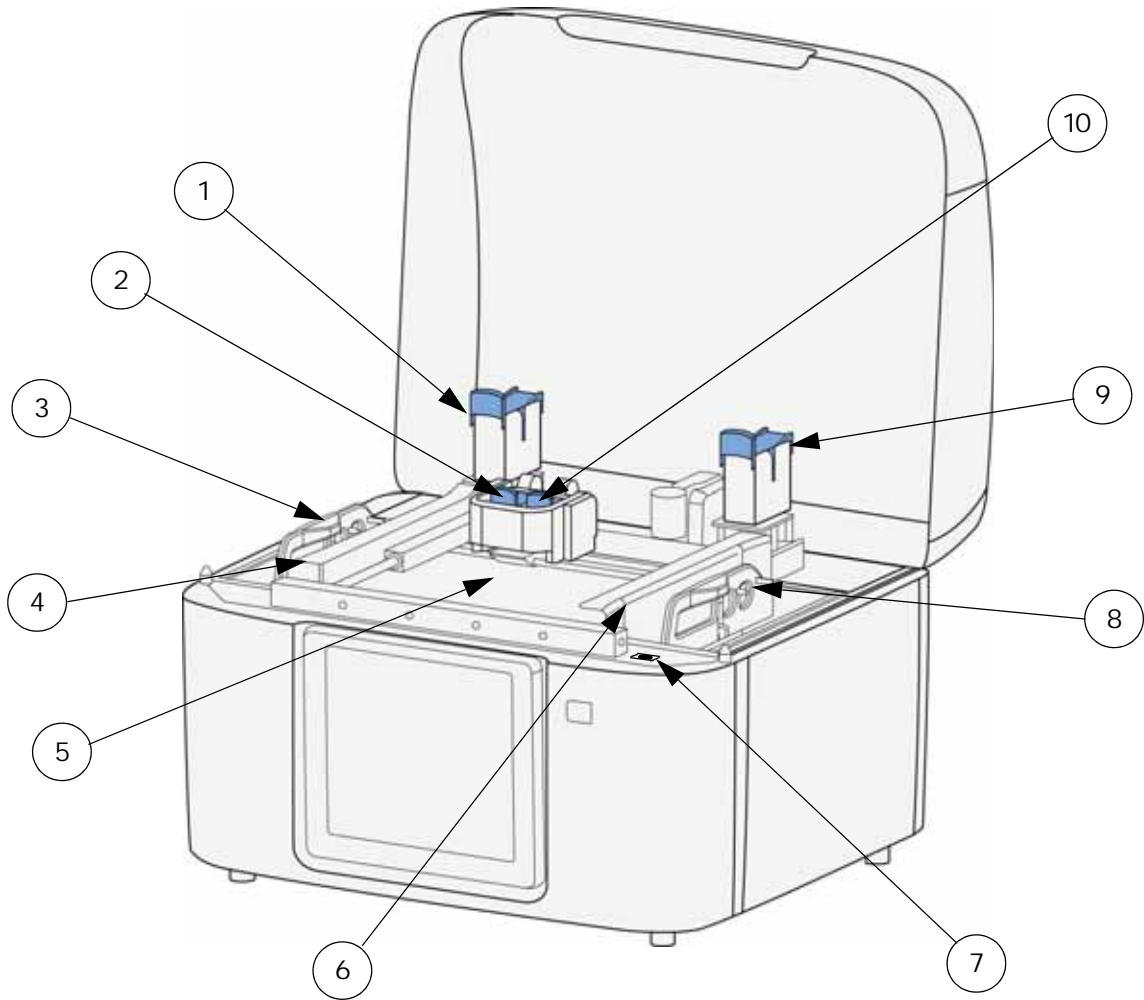

1	Model material sensor
2	Model head socket assembly
3	Mojo QuickPack Print Engine - <i>ABSplus</i>
4	Model material bay
5	Bellows
6	Support material bay
7	Cover sensor
8	Mojo QuickPack Print Engine - SR-30 support
9	Support material sensor
10	Support head socket assembly

Figure 3 Left side of printer

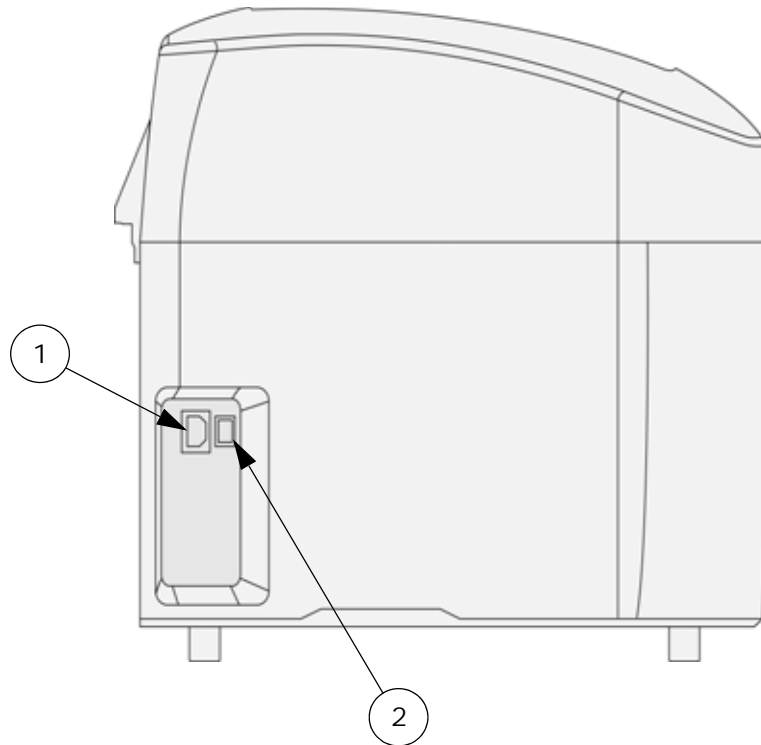

-
- 1 AC power cord connector
 - 2 Power ON/OFF switch
-

Figure 4 Rear view of printer

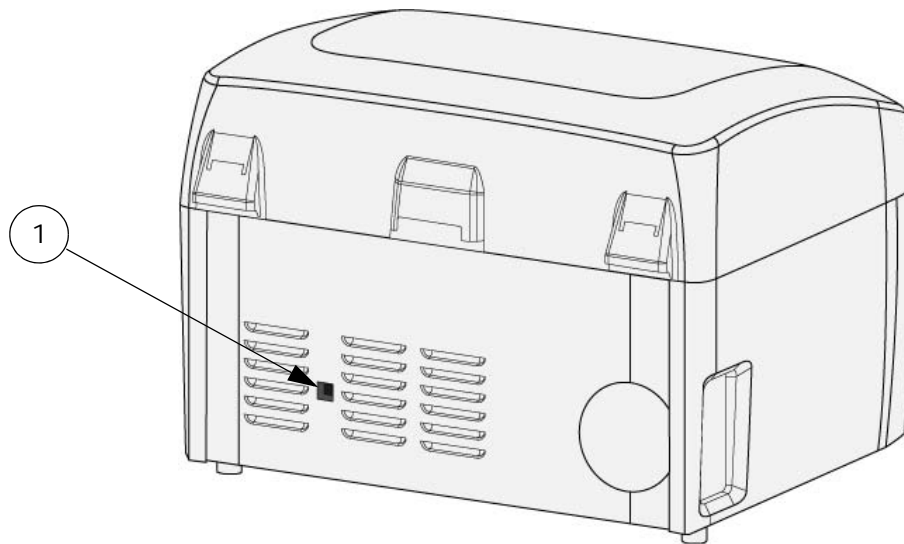

-
- 1 USB cable connector
-

Figure 5 Mojo QuickPack Print Engines

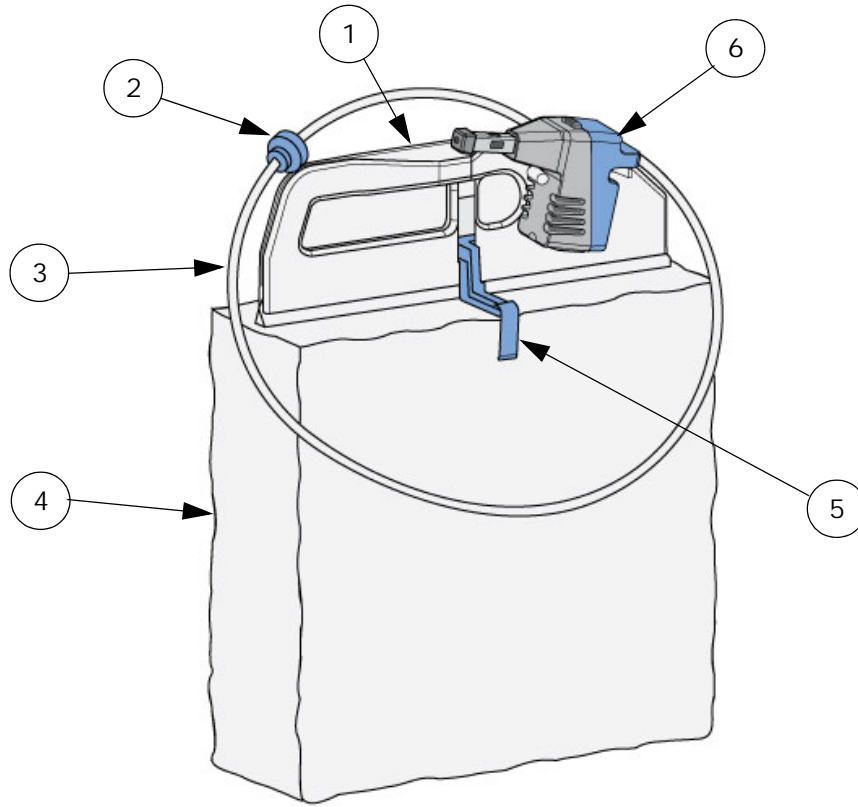

-
- | | |
|---|--------|
| 1 | Handle |
|---|--------|
-
- | | |
|---|---------------------|
| 2 | Material tube guide |
|---|---------------------|
-
- | | |
|---|---------------|
| 3 | Material tube |
|---|---------------|
-
- | | |
|---|--|
| 4 | Material container bag (do not remove) |
|---|--|
-
- | | |
|---|-------------|
| 5 | Locking tab |
|---|-------------|
-
- | | |
|---|------------|
| 6 | Print head |
|---|------------|
-

Figure 6 Startup supplies

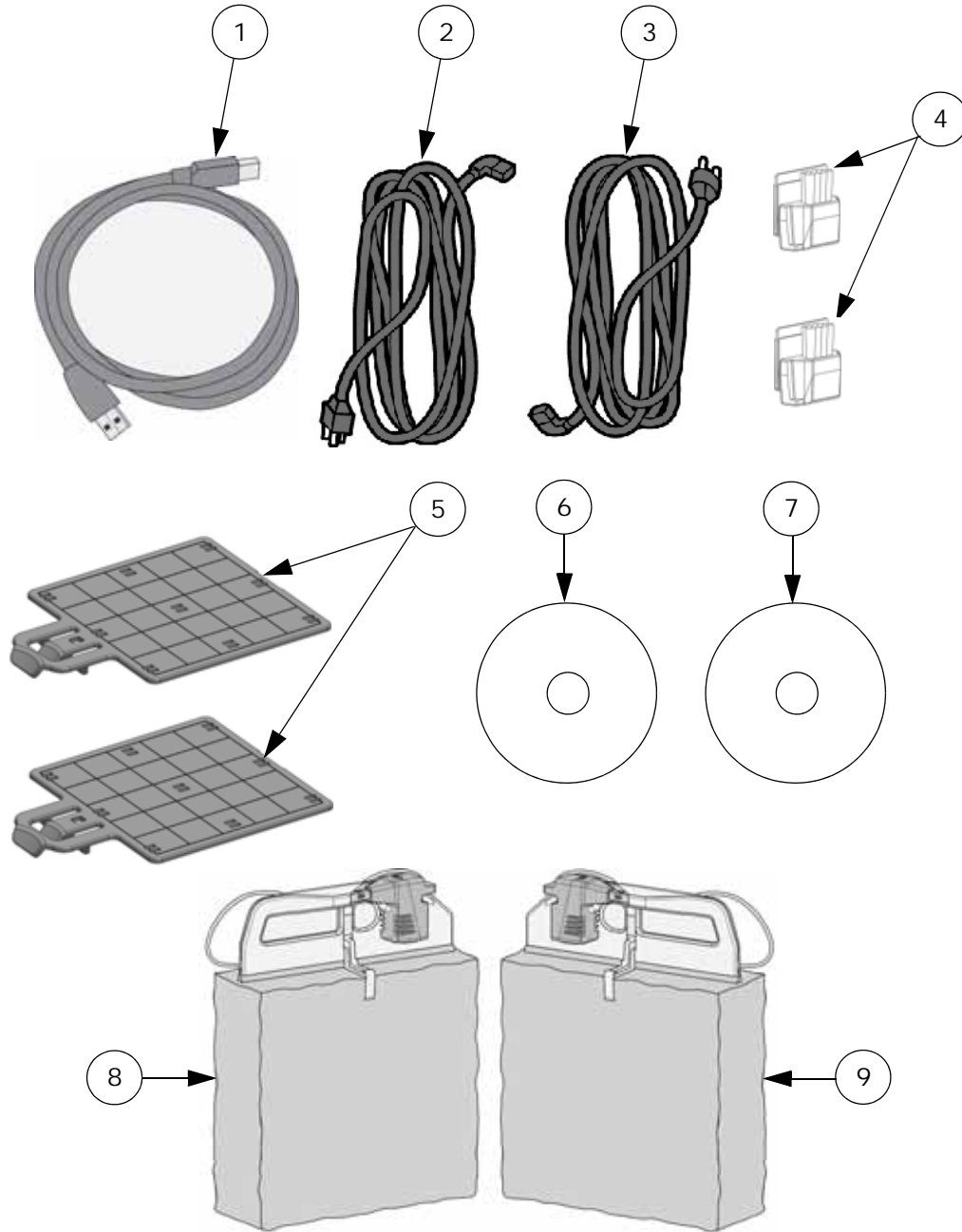

- | | |
|---|--|
| 1 | USB Cable |
| 2 | Power cord (Euro) |
| 3 | Power cord (US) |
| 4 | Tip wipe assembly (2X) |
| 5 | Modeling base (2X) |
| 6 | Mojo Print Wizard Software |
| 7 | Mojo 3D Printer Software |
| 8 | Model Material Print Engine (Starter: 20 ci/328 ci) |
| 9 | Support Material Print Engine (Starter: 8 ci/131 ci) |

3 Setup

Set up the printer using the setup instructions included with printer.

Connecting the system

Make sure the following preparations of the physical site are met:

- The system must be placed on a flat and stable surface able to support 34.1 kg (75 lbs.) to avoid the risk of falling.
- The work area for unpacking the system should be 1.22 m (48 in.) high, 1.83 m (72 in.) wide and 1.02 m (40 in.) deep.
- The grounded electrical outlet (6A @100-127VAC or 2.5A @ 220-240VAC -- 50/60 Hz 600W) must connect to either a Euro or a US power cord plug provided and must be located within 2 m (80 in.) of the system. Do not use an extension cord or a power strip. Using these can possibly cause intermittent power issues.
- The operating environmental temperature must be between 15°C to 30°C (59°F to 86°F).
- The operating environmental humidity must be between 20% to 80% RH non condensing.

Connecting the power

1. Connect the power cord for your region between the printer and a grounded power outlet.

Figure 7 Connecting the power

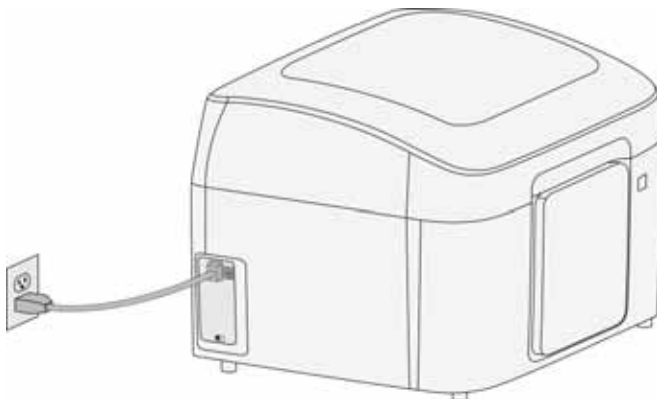

2. Turn the power switch to the ON (I) position.

Figure 8 Turn on the power

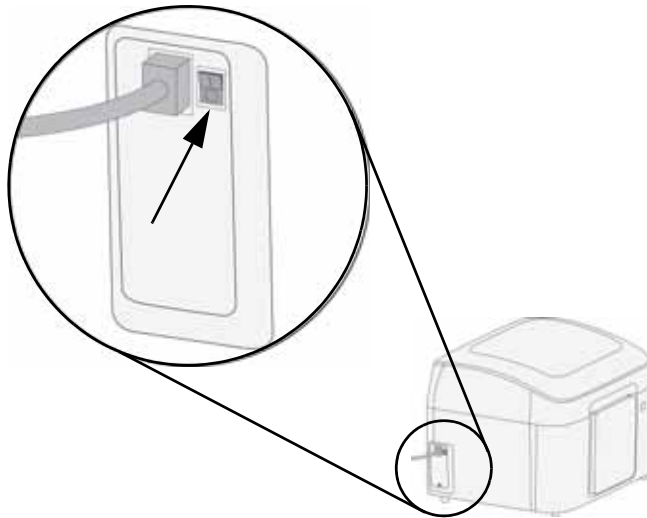

3. The LED display will cycle through a test sequence. When complete the display will turn red. After communication has been established to the host computer, the display will turn green. The green LED indicates the printer is ready to build.

Figure 9 LED test sequence

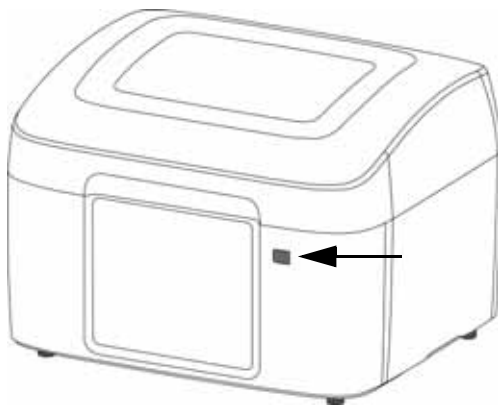

Installing software



Note: Make sure the “Windows automatic update” feature is turned off on the host computer. Loss of part will occur if this feature is not turned off. See Windows support and help instructions on how to turn these features off.

The host computer is defined as the computer that is connected directly to the Mojo printer.

There are two software programs that are required for the Mojo printer:

- Mojo 3D printer software is used to send parts (processed by Print Wizard) to the printer.
- Print Wizard software installs on your computer or host computer and processes STL files for printing and communicating with the host computer.

Mojo 3D printer software

1. Locate the 3D Printer Software CD from the startup supplies and insert into the host computer CD drive.
2. Follow the prompts to load the 3D Printer software on the host computer..



Note: Connect the USB cable between the USB cable connector to the back of the printer and the host computer when prompted during software installation



Note: Do not use USB cables longer than 5 m (197 in.).

Figure 10 Loading Mojo 3D Printer software



Figure 11 Connecting the USB cable

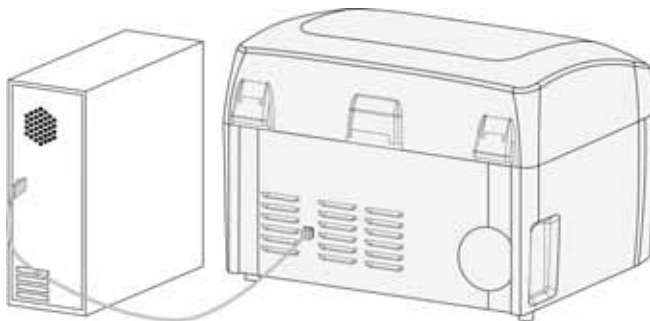

3. The software may take several minutes to load.

Print Wizard software

1. Locate the Print Wizard Software CD from the startup supplies and insert into your computer or host computer CD drive.
2. Follow the prompts to finish loading the Print Wizard software on your computer or host computer. The software may take approximately one minute to load.

Figure 12 Loading Print Wizard software







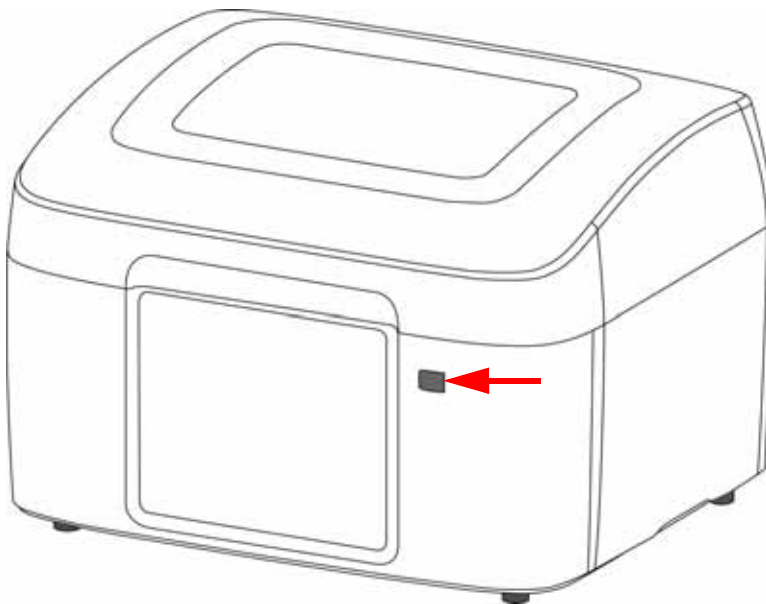

4 Operation

LED display

The LED display indicates the status of the printer.

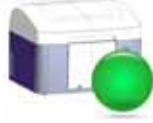





Figure 13 LED display



LED	LED Display Status
	Idle/Build
	Door or cover open
	User/Pause
	Machine pause
	User Cancel
	Failure

Printer status icons

Icons show printer status in both 3D printer software and Print Wizard.

Printer Icon	Printer Status Discription
	Error
	Idle
	Disconnected
	Out of material
	Part done
	Paused
	Printing
	Part canceled

Print Wizard/3D Printer software overview



Note: Make sure the “Windows automatic update” feature is turned off on the host computer. Loss of part will occur if this feature is not turned off.

Print Wizard software can be installed on multiple computers so parts (files) can be sent to the host computer over a local area network.

- 3D Printer software is installed on the host computer and is used to send files to the printer.
- 3D Printer software only needs to be installed on the host computer.
- Only one Mojo printer can be connected to the host computer.

Figure 14 Network overview

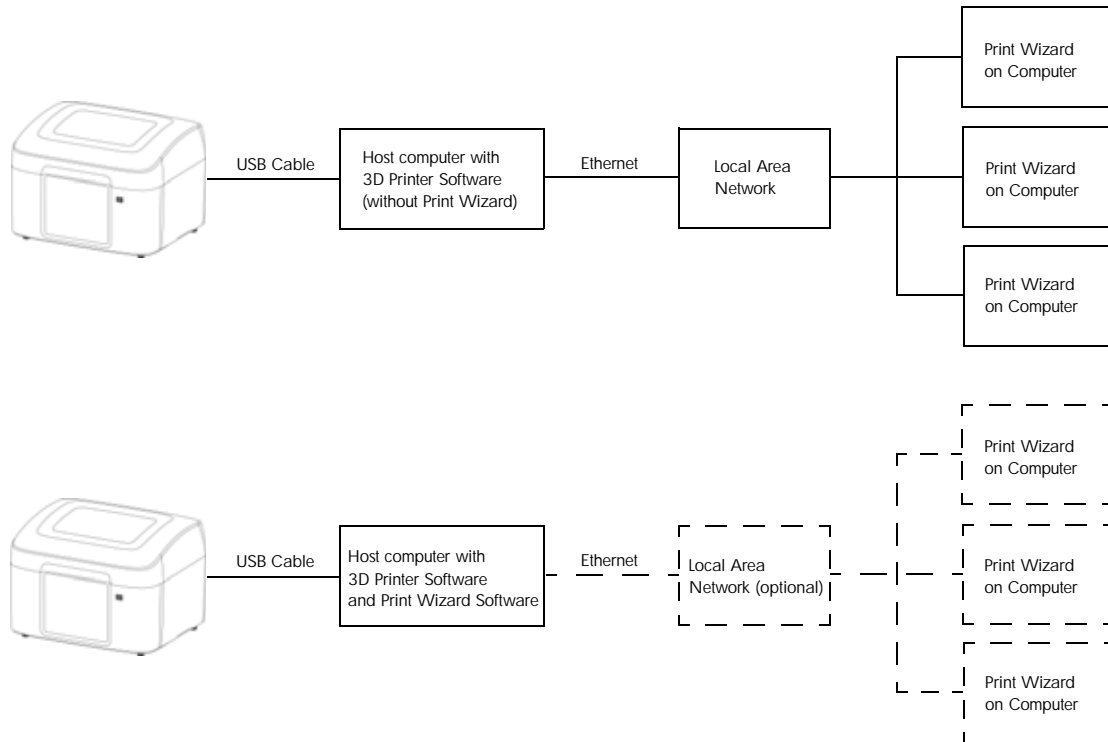

Installing a modeling base



Note: Re-use of modeling bases is not recommended.



Hot Surface: The metal surfaces inside of the chamber can be hot. Use extra care when working around heated components.

Always make sure there is a modeling base in the printer before printing a part.

1. Install the modeling base by aligning the base tabs into the slots on the platen.
2. Push the modeling base onto the platen making sure the base “clicks” into position.
3. Close the door.

Figure 15 Installing modeling base

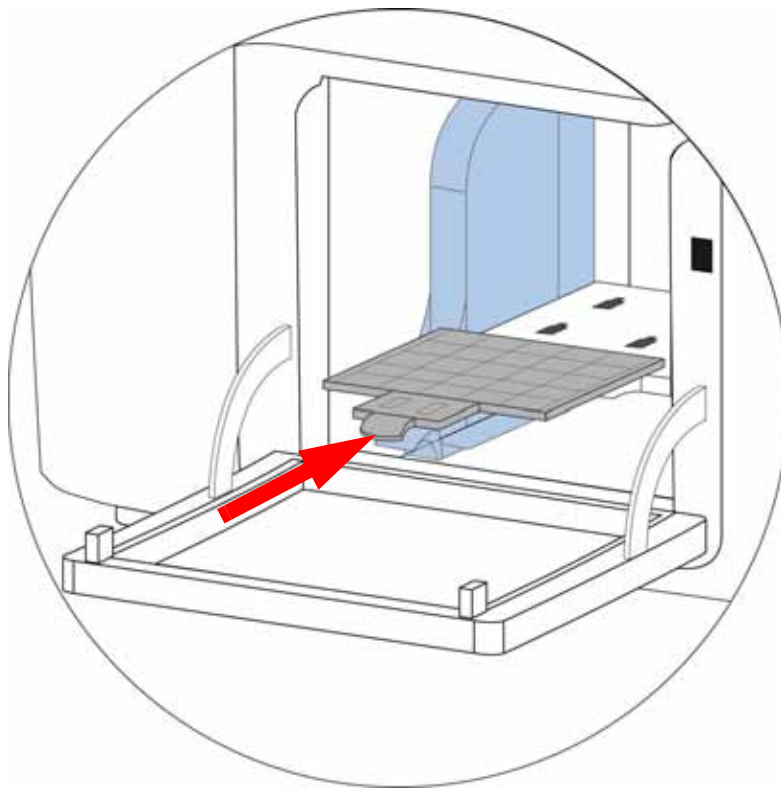

Processing your STL file for printing

Opening Print Wizard

Create an STL file using your CAD software. Refer to your CAD software help section for more information about converting your CAD drawings into STL files.

There are several ways of starting Print Wizard:

- From the Start Menu, select **Print Wizard** and then select one or more STL files from the STL file list. Holding the **Ctrl** key down allows the selection of multiple parts. Use the Windows Explorer tool bar to select the viewing options.
- From Windows Explorer, select the path where you store your STL files and then double-click a single STL file to open.
- From Windows Explorer, select the path where you store your STL file and using the Windows Explorer function, select several STL files. Use Ctrl left-click to select more than one STL file. Right-click and select **Print 3D** to open the files.

Select Large Icons or Extra Large Icons to view thumbnail images of the parts.

Selecting a printer

1. Click **MyPrinter** and the following drop-down menu will appear.
2. Select the printer to be used.
3. For adding additional printers see ["Adding additional printers" on page 18](#).

Figure 16 Selecting a printer

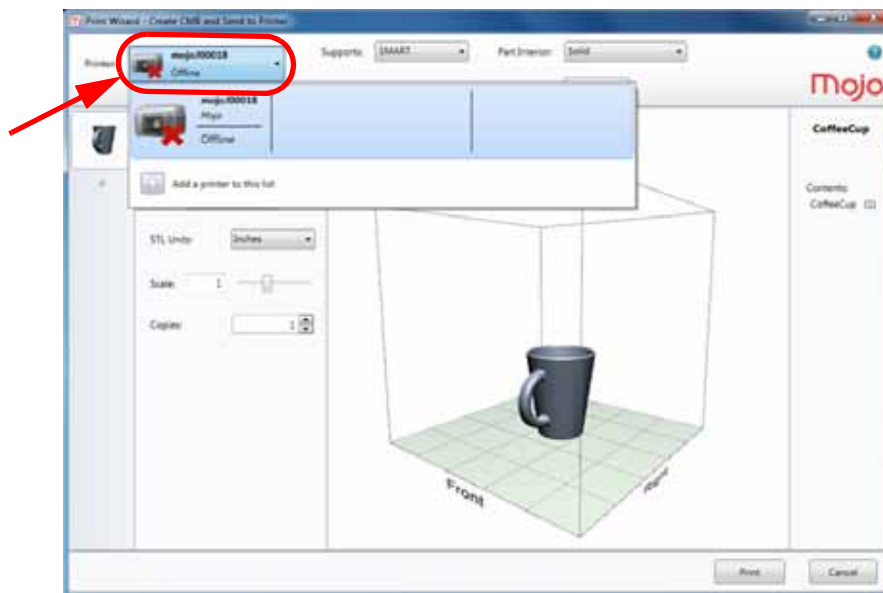

Adding additional printers

To add another printer, click **MyPrinter** and the following drop-down menu will appear. Click the

 **Add a printer to this list** icon.

Figure 17 Adding a printer

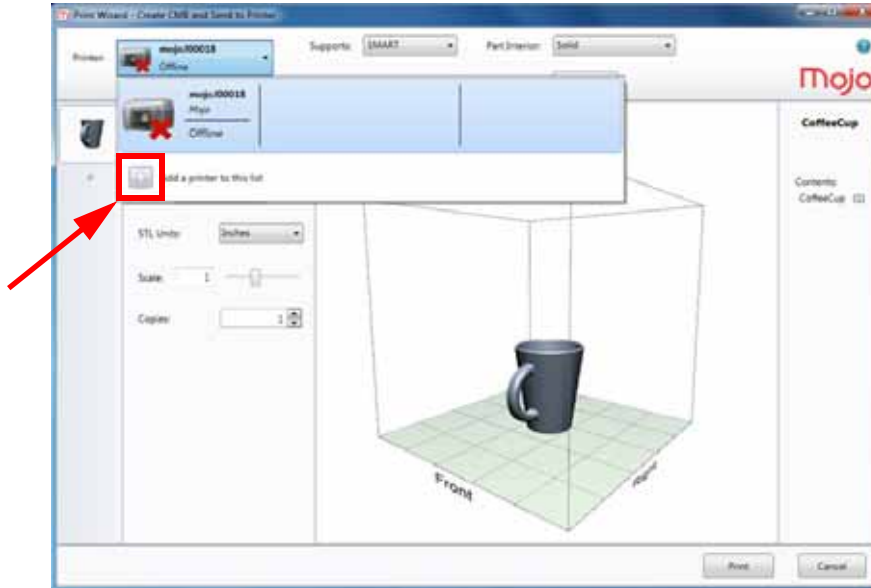

Obtain the host computer IP address from your network administrator. Enter the IP address of the host computer connected to the printer in the boxes provided, and then press **OK** or from the menu on the Mojo control panel on the host computer.

Figure 18 Entering an IP address

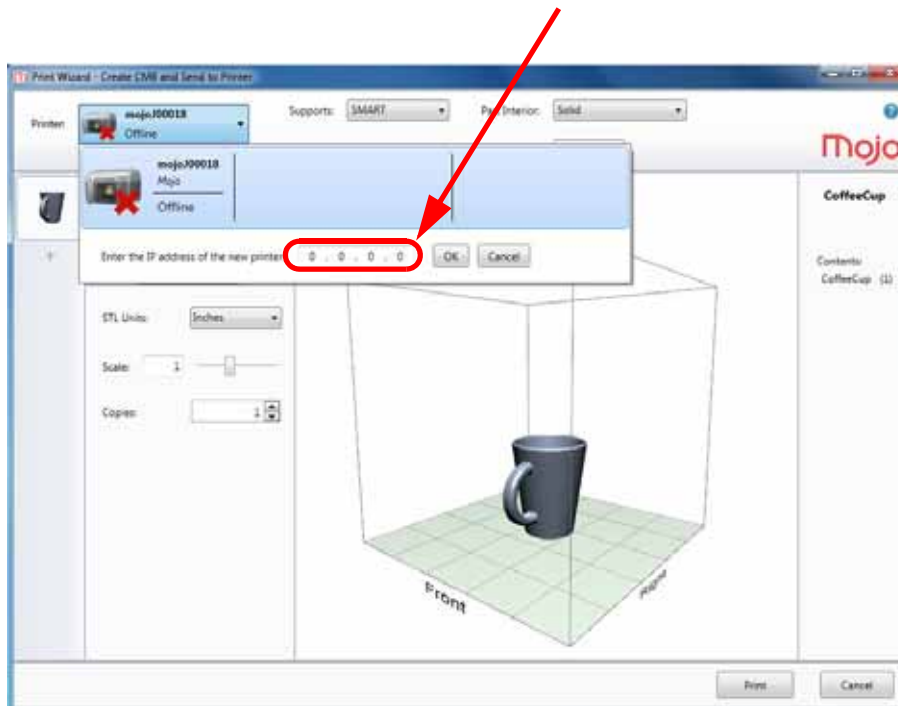

Selecting support style

Supports are used to support the part during the build process. Supports are removed when the part is complete. Support styles will affect the support strength and build time of the print. SMART support is the default setting.

Figure 19 Support style

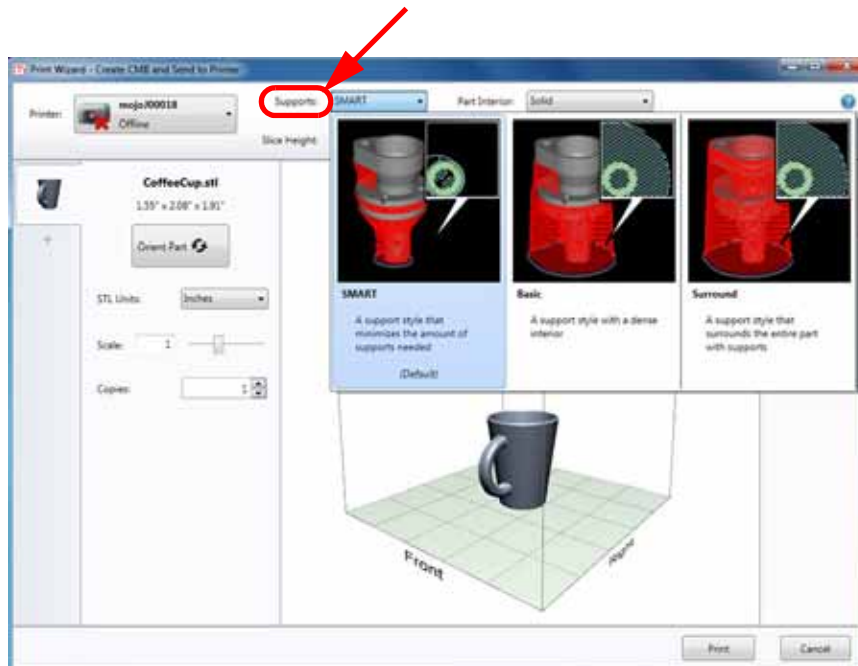

- **SMART (default)** - Minimizes the amount of support material used, reduces the print time, and improves support removal for many parts. SMART support uses a consistent spacing between support toolpaths and is less dense than Basic.
- **Basic** - May be used for most parts. Basic support uses a consistent spacing between support toolpaths.
- **Surround** - The entire part is surrounded by support material. Typically used for tall, thin parts.

Selecting part interior

Model interior establishes the type of fill for the interior solid area of the part. Solid is the default setting.

Figure 20 Part Interior

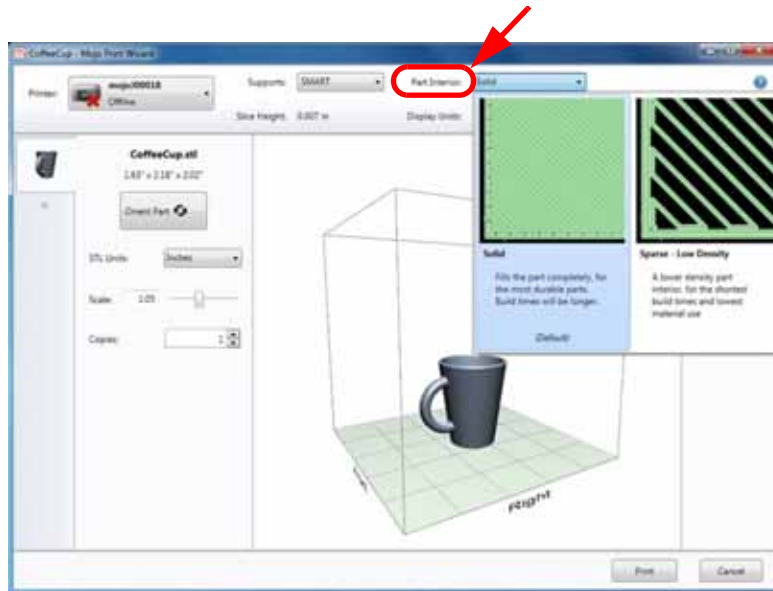

- **Solid (default)** - Fills the part completely for the most durable parts. Build times will be longer.
- **Sparse - Low Density** - A lower density part interior for the shortest build times and lowest material use.

Selecting display units

Display units can be selected for English or Metric measurement. The STL file selected will display the size of the part under the file name. Display units determines whether the part size is displayed in millimeters or inches. The unit selected will also be reflected in material information in the Mojo Control Panel window.

Figure 21 Display units

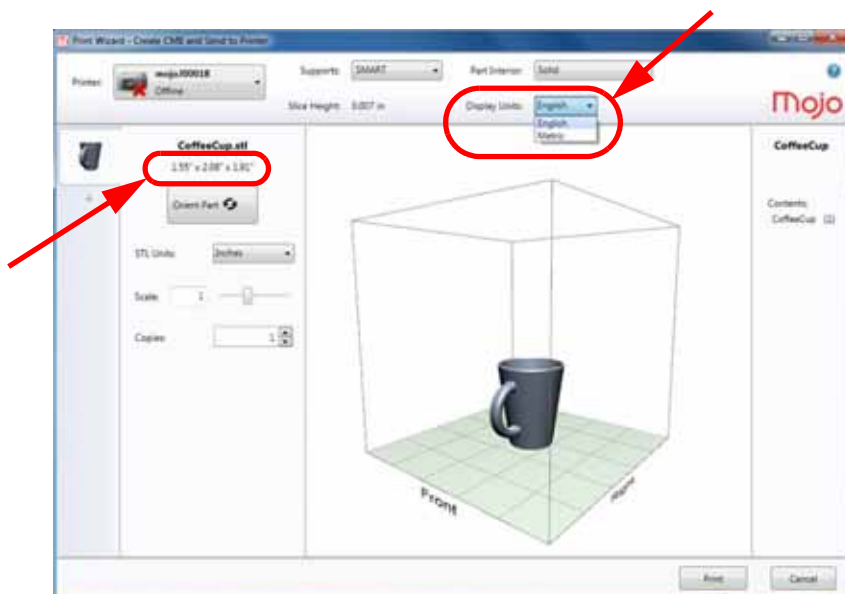



Selecting the orientation of your part

The orientation function displays an expanded preview window that shows the orientation of the part when it prints. Orientation impacts build speed, part strength, surface finish and material consumption.

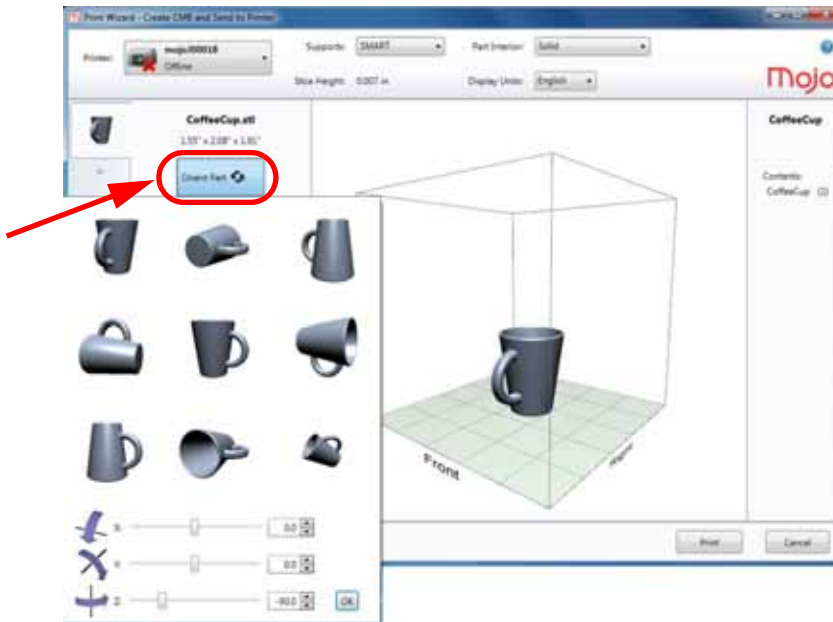
Figure 22 Part orientation



You can change the orientation of your part by clicking the **Orient Part** button and then selecting the orientation desired from the preview window. The selected part can be further manipulated by using any of the X, Y, or Z axis slide controls or by adding a specific value. When the desired orientation is achieved, click **OK** to save the settings.

Icon	Description
	Rotates the displayed part around the X axis.
	Rotates the displayed part around the Y axis.
	Rotates the displayed part around the Z axis.

Orientation considerations

- **Build Speed/Material Usage** A lesser amount of supports will allow for a faster build speed. Another factor affecting build speed is the axis orientation. The printer can build faster across the X-Y plane than it can along the Z axis. Orienting a part so that it is shorter within the printing chamber will produce a faster build.
- **Part Strength** - A part is stronger within a layer than it is across layers. You may need to orient your part to have its greatest strength across a specific area. For example a tab that needs to be pressed would be weakest if you are applying pressure across layers.
- **Surface Finish** - Orientation will affect the surface finish in specific areas of the part. How the part is oriented will determine how the surface finish will look and allow the printer to provide the smoothest finish for a specific area. For example, if printing a cylinder, orienting the cylinder upright will have a smoother surface finish than printing it on its side.

Rotating the part view

Left click on the part and then drag the mouse to the left or right to rotate the view within the chamber. This will provide viewing of the front, left side, back, and right side views of the part(s) being printed.

Figure 23 Rotating the view

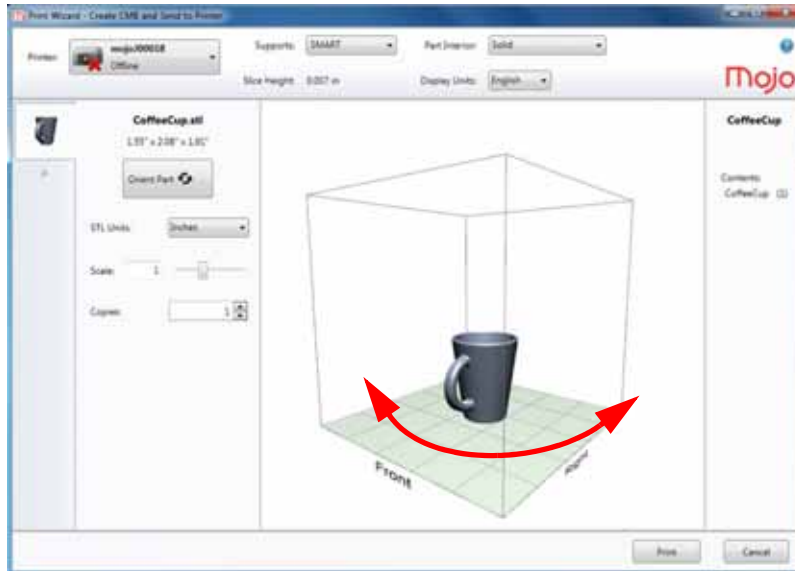

Selecting the scale of your part

Before you process a part for printing, you can change the size of the part within the build chamber. If parts are too large to fit in the build chamber when the STL file is first loaded, they are automatically scaled to fit the build chamber. If the part is automatically scaled to fit the build chamber, the scale box will turn red. The part size can be changed by entering a scale number or by using the slider control. Every part has a pre-defined size within the STL file. After you have opened the file you can change the size of the part produced by changing the scale. The scale always relates to the original STL size of the part as defined in the STL file.

Figure 24 Scaling

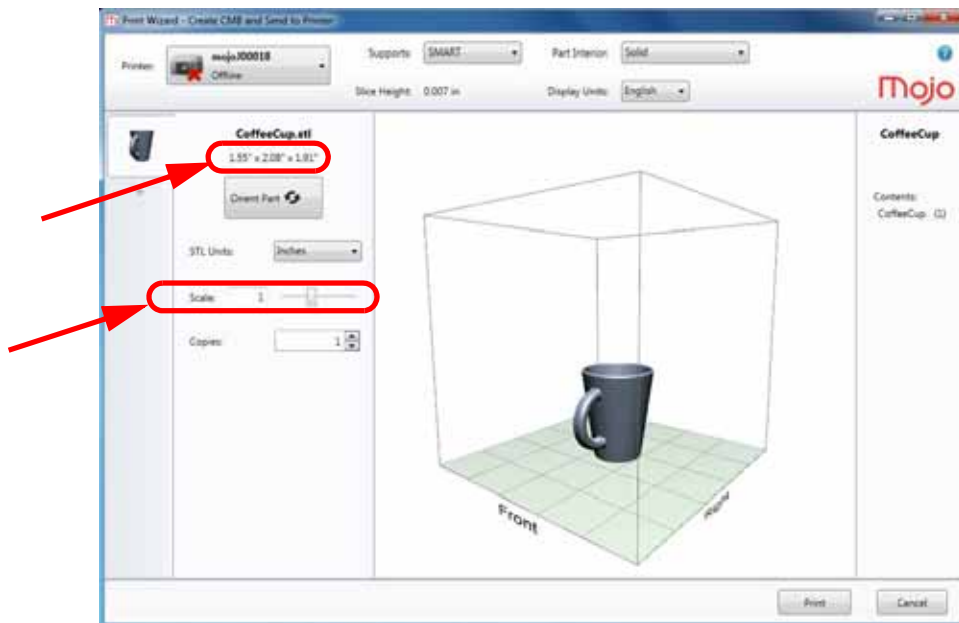

For example: a cube that is defined as 5.1 cm (2 in.) X 5.1 cm (2 in.) X 5.1 cm (2 in.) can be built to be 10.2 cm (4 in.) X 10.2 cm (4 in.) X 10.2 cm (4 in.) by simply changing the scale to 2. If after changing the scale to 2, you decide that a size of 7.6 cm (3 in.) X 7.6 cm (3 in.) X 7.6 cm (3 in.) would be preferred, change the scale to 1.5 - the scale relates to the original size of 2 inches, NOT the resulting 4 inches from the first scale change.

Selecting the number of copies

Users may choose the number of copies (parts) to be printed. The printer will automatically calculate the number of parts that can be printed on the modeling base. As the number of copies are increased, the printer may add another job.

Figure 25 Number of copies

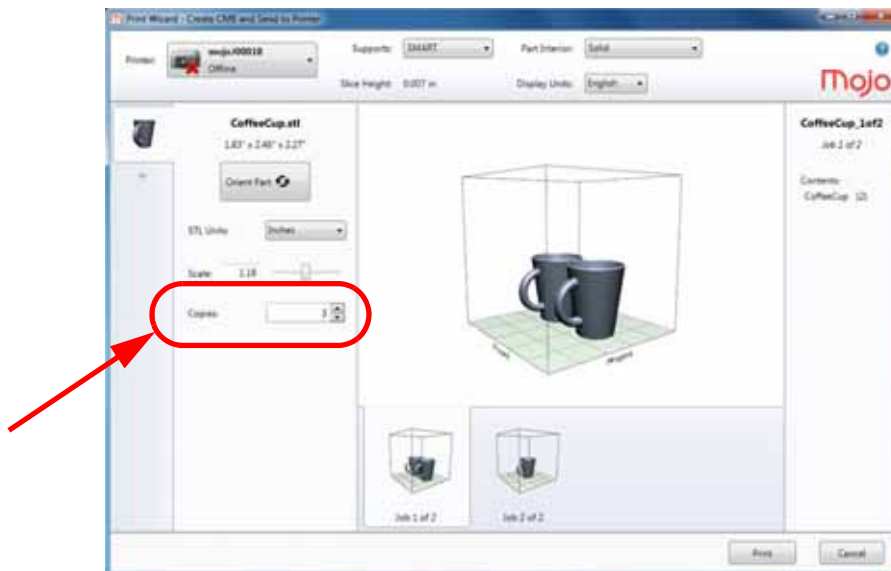

Job creation

Print Wizard automatically calculates the size and number of parts that can be printed on the modeling base. If the size and number of the part are too large, Print Wizard will add another job.

The number of jobs created is based on:

- Part dimension
- Part orientation
- Scale
- Number of copies

Figure 26 Job added

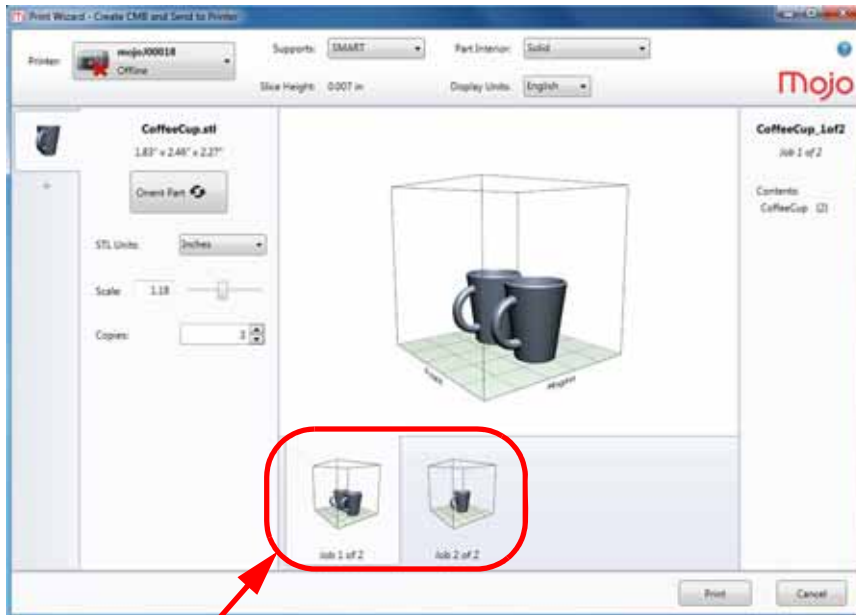

Note: All jobs displayed will be sent to the host computer when the **Print** button is clicked.

Adding/removing parts

STL files can be added to the job by:

- Double-clicking an STL file.
- Using the drag-and-drop feature of Windows Explorer to move the file into the print window.
- By clicking the “+” sign.

 **Note:** Once the STL file is brought into Print Wizard, the file is then considered a part.

Figure 27 Drag-and-drop new STL file



A part is removed by right clicking on the part and then selecting “Remove Part”.

Figure 28 Removing a part

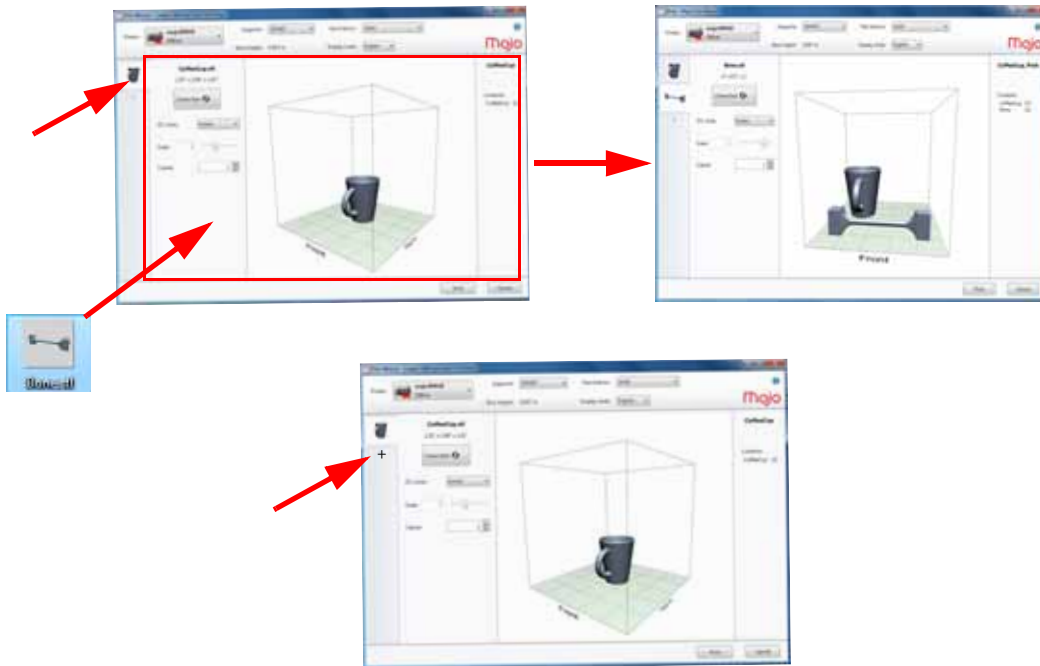
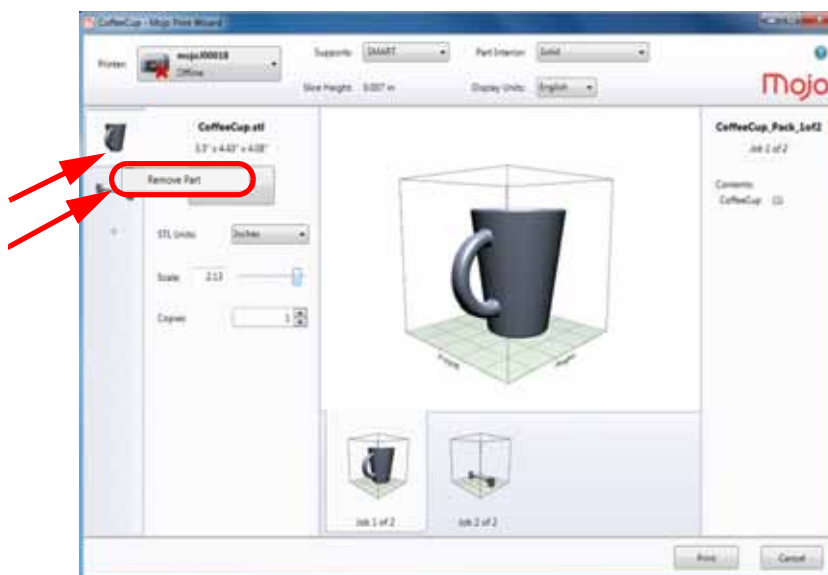

STL part content information

The name of the STL file and the quantity of parts to be printed for each job are displayed in the window. A thumbnail view of the individual part(s) for all jobs are displayed on the left hand side of the Print Wizard screen.

Figure 29 Print Wizard screen

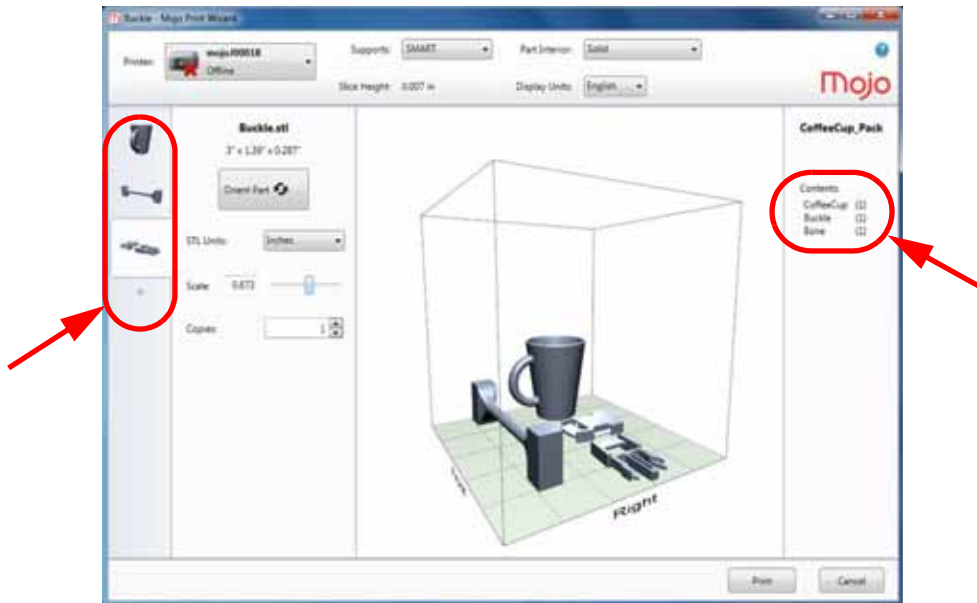

Processing the part

After the part(s) have been selected, click the **Print** button. When the **Print** button is clicked, the part(s) will be processed and sent to the host computer.

Figure 30 Print button

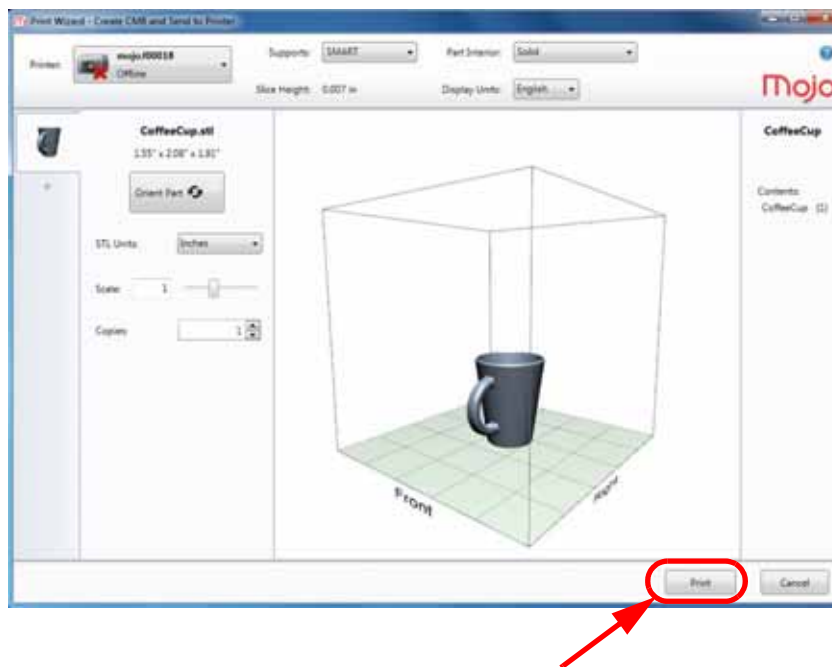

The following window will be displayed while processing the part.

Figure 31 Processing

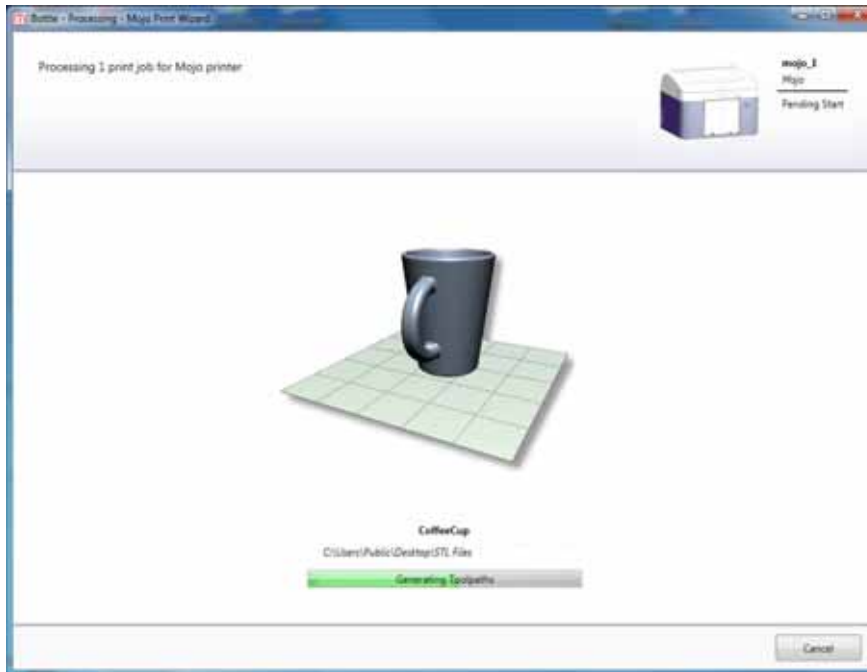

The following window will display a list of all processed jobs along with time and material estimates. Processed parts can be later selected using the Control Panel select part drop-down menu.

Figure 32 Processed parts list

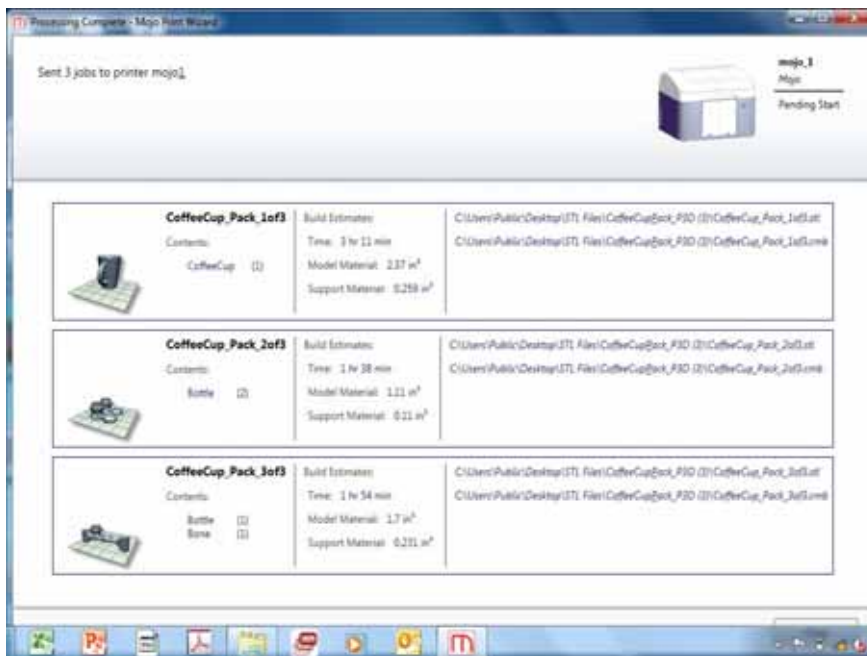

Printing a part from Mojo Control Panel

Once parts are processed in Print Wizard, they can then be printed using Mojo 3D printer software on the host computer.

1. Open Mojo Control Panel and the window below appears. The following information is displayed:

- Remaining model and support material on QuickPack Print Engines
- User name
- Date and time part was submitted
- Estimated print time
- Estimated model and support material required to print the part
- Estimated completion time of the part
- Current layer status

Figure 33 Mojo Control panel

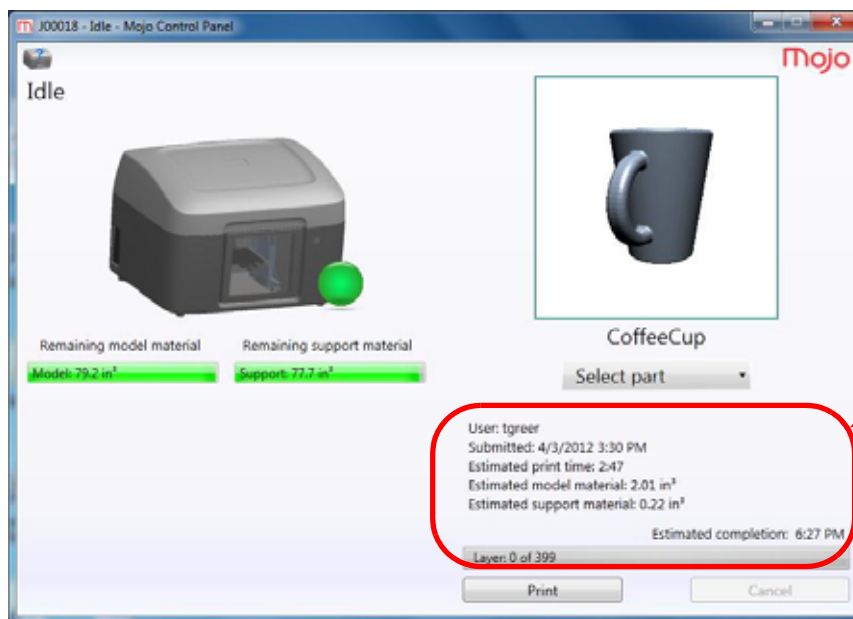

2. Click **Select part** from the drop down menu and select the part to be printed. The first processed part will be displayed in the preview window with the part name.

Figure 34 Part selection

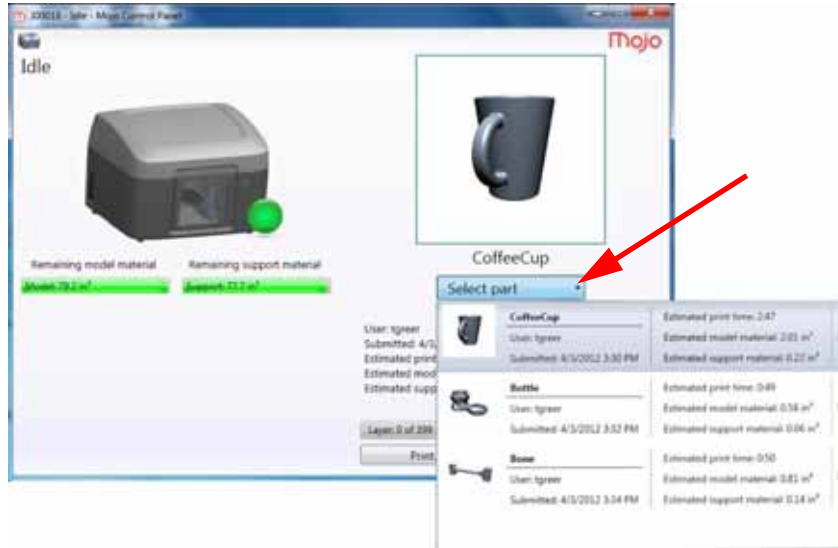

3. Click **Print** to begin printing.



Note: If there is not enough model or support material available in the QuickPack Print Engine to complete the part, the part will not print.

As the part is being printed, the following general information will be displayed:

- Printer status
- Material usage
- Estimated completion time

The following window will be displayed while the part is preparing to be printed.

Figure 35 Preparing to print

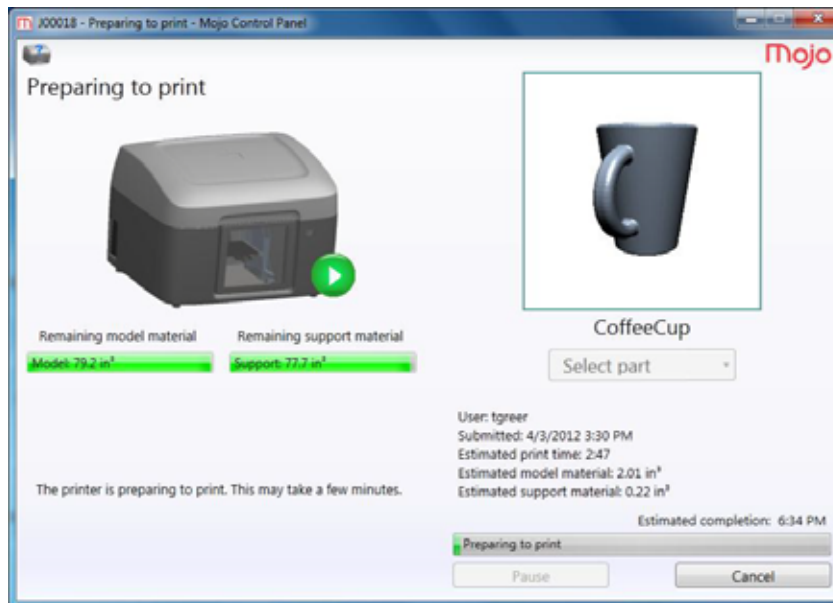

The following window will be display while the part is printing.

Figure 36 Printing

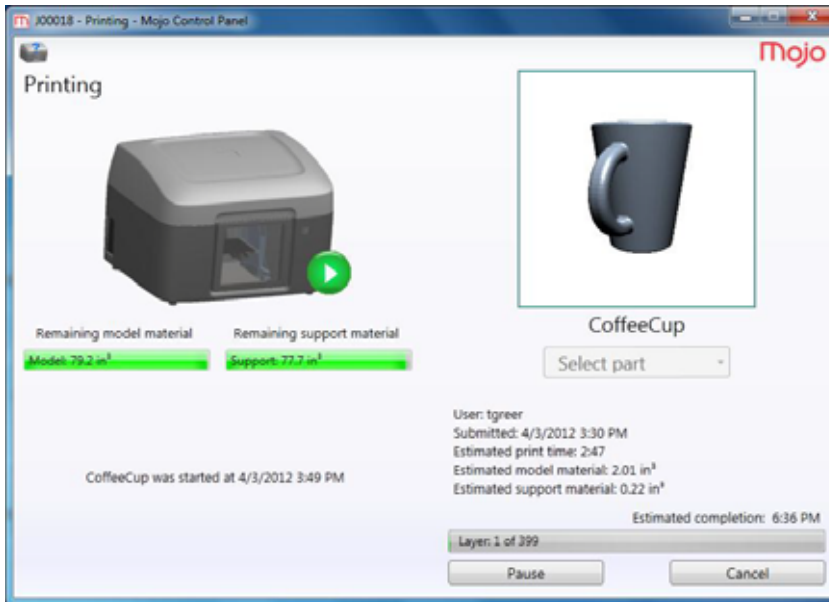

If the printer is paused, the following window will be displayed. Click **Resume** to continue printing.

Figure 37 Paused

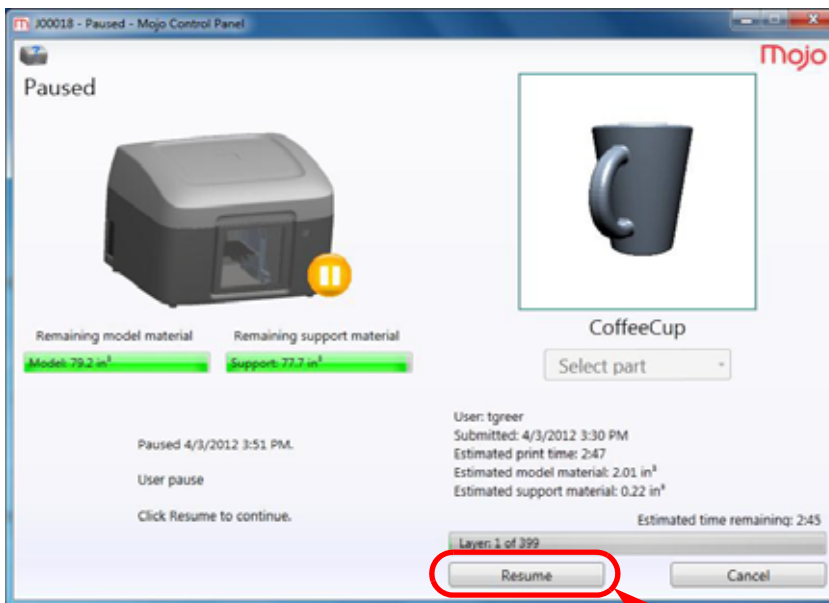

If a printer fault occurs during printing, specific information will be displayed in the window. Refer to Troubleshooting in Section 6 for additional information.

Figure 38 Fault

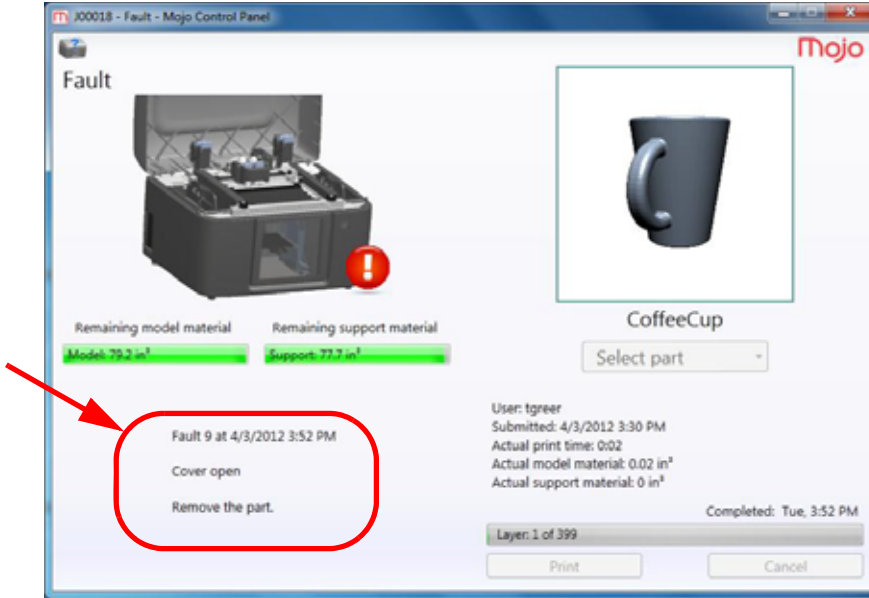

Control Panel Drop-Down Menu

The information icon provides a drop-down menu for additional printer functions.

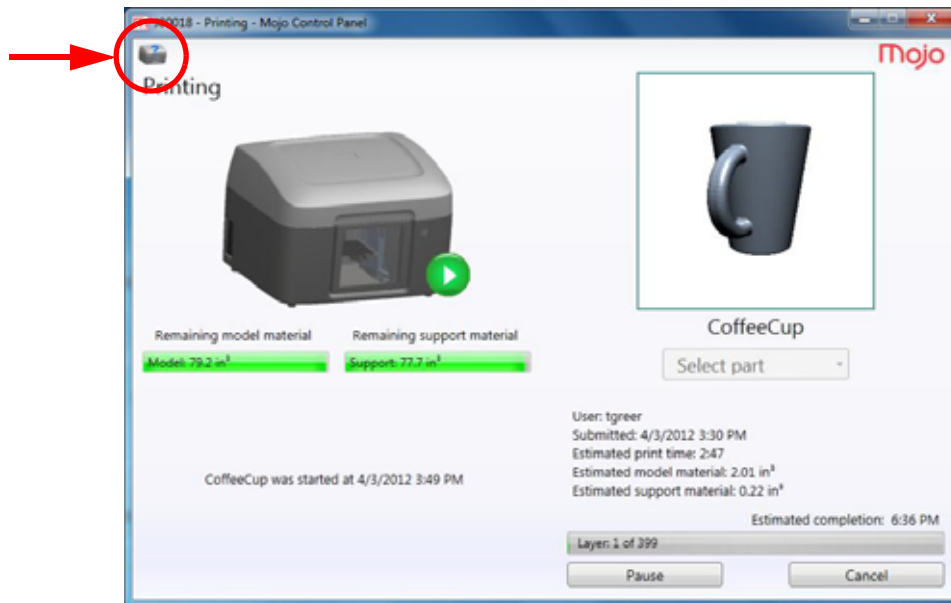

By clicking the Information Icon, a drop-down menu will appear with the following selections.

Attempt to clear the error

If certain errors occur, selecting "Attempt to clear the error" will clear the error and continue the printing process.

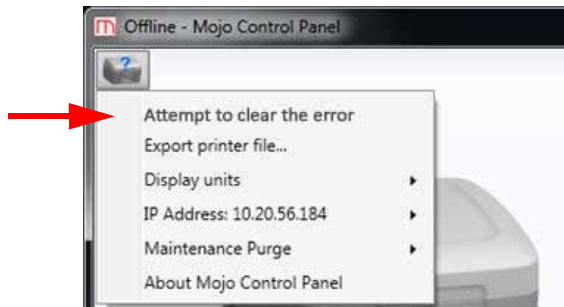

Export printer file

To better diagnose printer issues, you may need to export the printer configuration file (.cfg) from your printer and send it to your Service Provider.

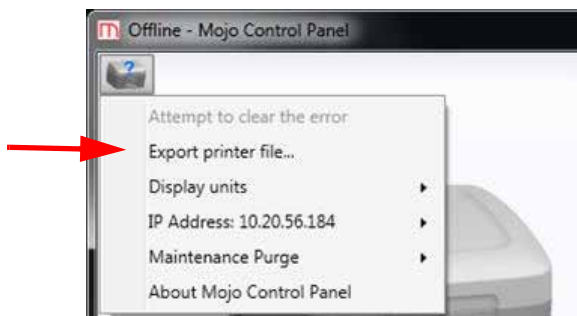

1. Select **Export printer file...**
2. Browse to the directory where you wish to save the configuration file (.cfg).
3. Click the **Save** button.

Display units

Display units can be selected for English or Metric measurement.

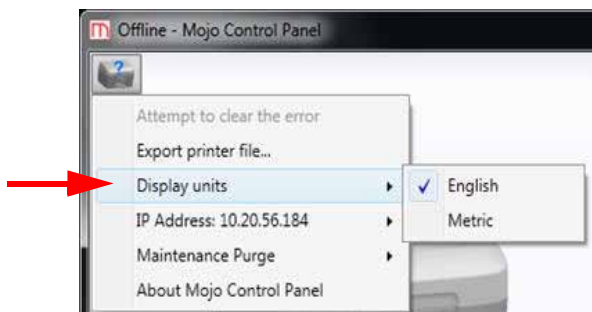

IP address

The IP address of the host computer that is connected to the printer can be copied to the clipboard on the host computer.

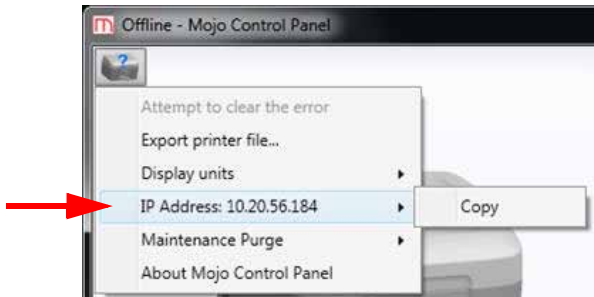

Maintenance purge

Maintenance purge is a way to verify that a QuickPack is extruding correctly or to purge out wet material from the filament tube. It takes two maintenance purges to purge out all of the material in the filament tube. The maintenance purge will purge material into air in the center of the build area. After a maintenance purge completes, it is necessary to open the printer door and remove the purged material from the center of the build area.



Note: If an opened QuickPack Print Engine has not been used in over two weeks, two maintenance purges should be performed.

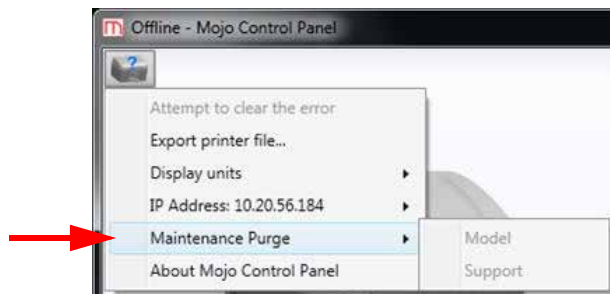

1. Click on the printer information icon in the upper left of the Mojo Control Panel window.
2. Select **Maintenance Purge**.
3. Select either **Model** or **Support** to be purged.
4. Wait for the liquefier to heat and purge to complete.
5. Remove the purged material from the center of the build area.

About Mojo Control Panel

Displays Control Panel version and build number.

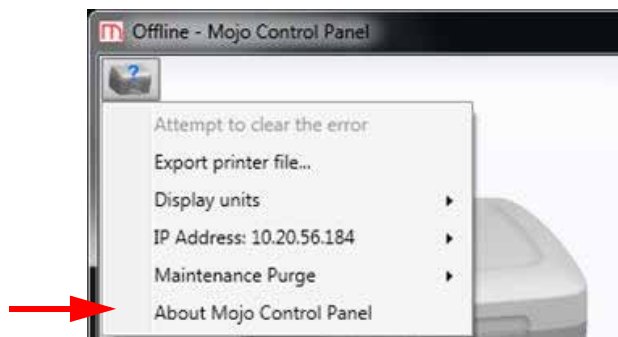

Removing a completed part

When the job is complete, remove the part.



Hot Surface: The surfaces inside of the chamber can be hot. Use extra care when working around heated components.

1. Open the door.
2. Remove the modeling base by squeezing two tabs together while pulling the modeling base out of the chamber.
3. Close the door.

Figure 39 Modeling base removal

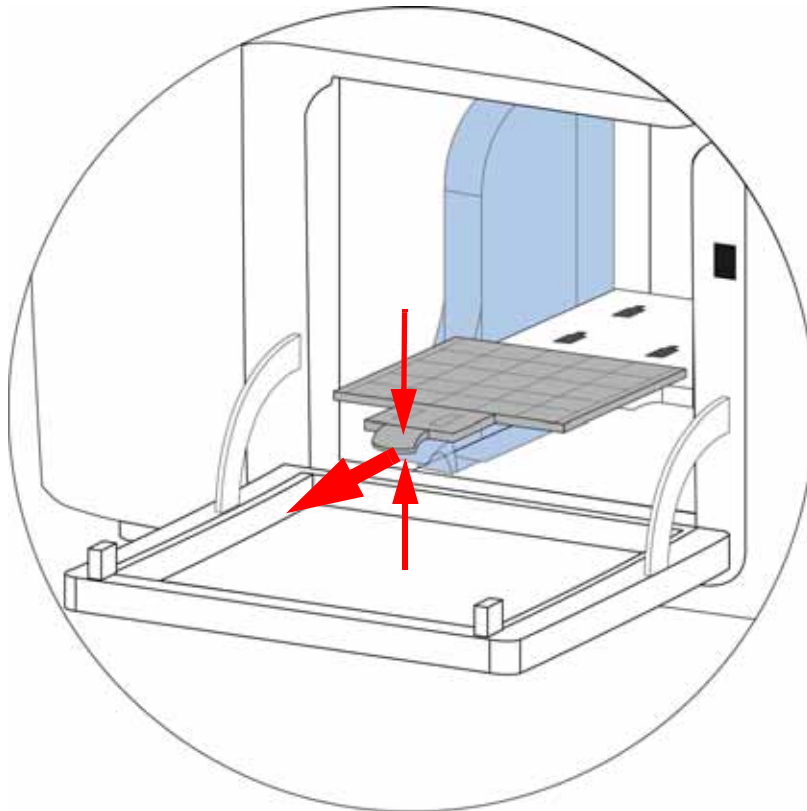

Remove a part from the modeling base

1. After removing the modeling base from the printer, firmly flex the modeling base back and forth with your hands to loosen the part.
2. Pull the part off of the modeling base or use a putty knife to completely remove the part.



Note: Parts are easier to remove from the modeling base when they are still warm.

Emptying the purge buckets

Empty the purge buckets on each side of the printer after each use to avoid part quality issues or damage to the printer.



Hot Surface: The surfaces inside of the chamber can be hot. Use extra care when working around heated components.

1. Squeeze the upper and lower tabs and then lift and pull the purge bucket out of the chamber.

Figure 40 Emptying the purge buckets

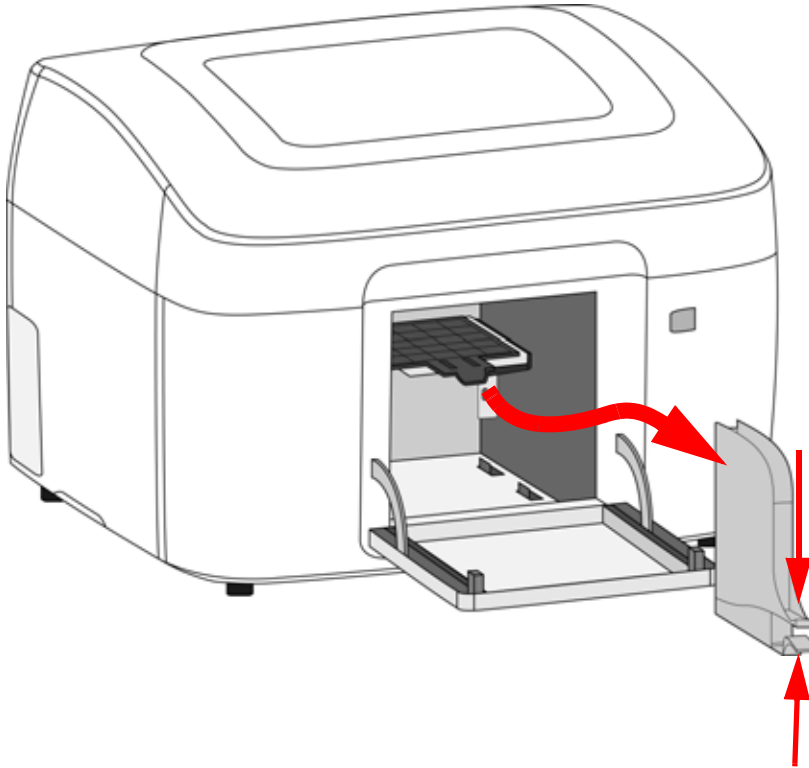

2. Empty the purge buckets.
3. Place the purge bucket in position then push the bucket into the chamber. Make sure the purge bucket "clicks" in place.

Removing support material

Mojo uses soluble support material which is designed to dissolve in a water based solution. Your part is left with a smooth and clean finish with the fine details intact. The soluble support material can be removed by hand with relative ease, but is designed to be dissolved from your parts for hands free finishing.

Powering off

To power off the printer, turn the power switch to the OFF position. This can be done at anytime without harming the printer. No other steps are necessary. If power is switched OFF while printing, the current part will not be completed.

Removing the QuickPack Print Engine

1. Open the cover.
2. Open the material sensor lid and remove the material tube guide from the material sensor.
3. Open the head socket lid and remove the print head.
4. Using the handle, lift up and remove the QuickPack Print Engine from the material bay.

Figure 41 Remove the QuickPack Print Engine

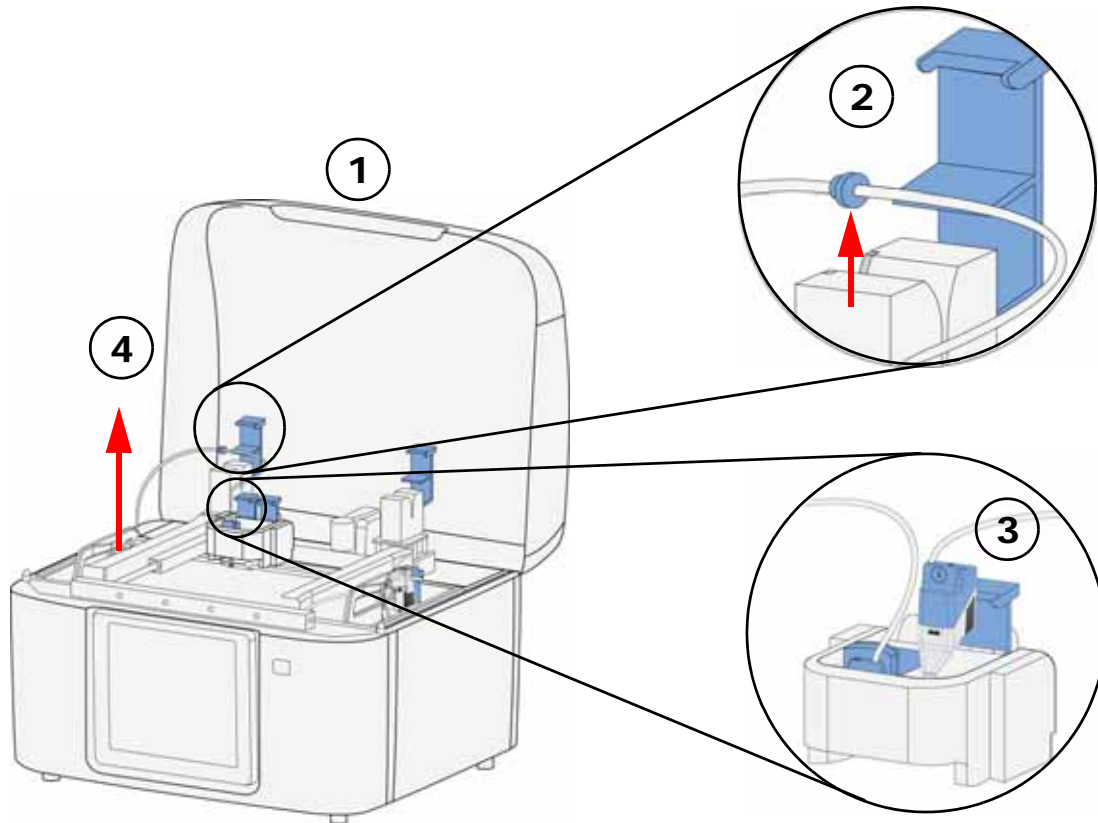

Storing QuickPack Print Engine

QuickPack Print Engines are best if used within one year from the date of manufacturing. The manufacturing date is printed on the QuickPack Print Engine bag. Always keep QuickPack Print Engines stored in a vertical position.



Note: If an opened QuickPack Print Engine has not been used in over two weeks, two maintenance purges should be performed (see [“Maintenance purge”](#) on page 34).

Storage Environment

Temperature range 0-35 °C (32-95 °F)

Humidity range 20-90% RH

1. Remove QuickPack Print Engine from the printer.
2. Clip the head into position on the handle.
3. Push the locking tab down to prevent material from unwinding.

Figure 42 QuickPack Print Engine

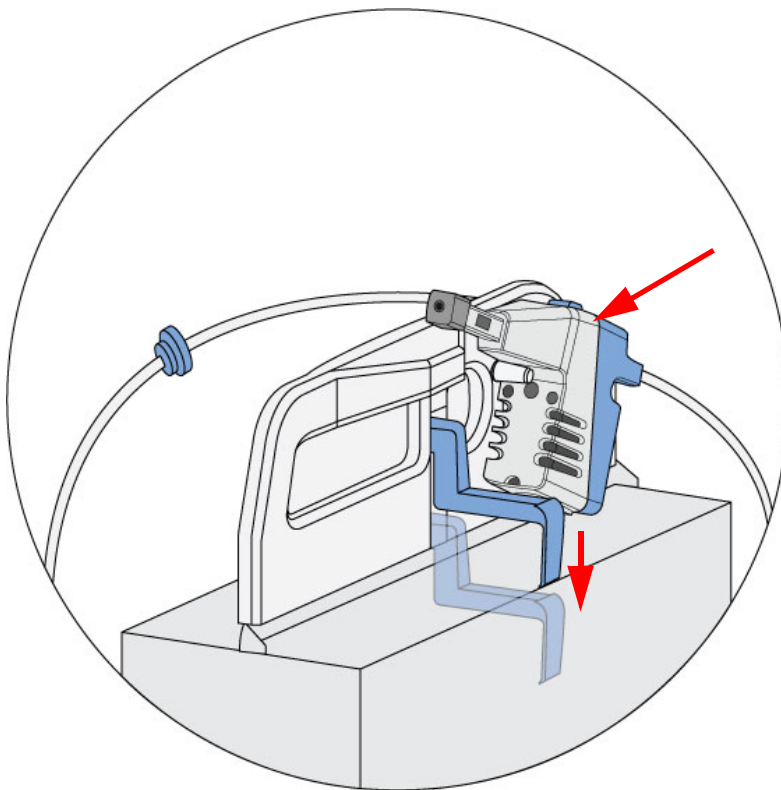

Replacing the QuickPack Print Engine

1. Remove the QuickPack Print Engine from its box.
2. Tear open the bag containing the QuickPack Print Engine.

Figure 43 Open Bag

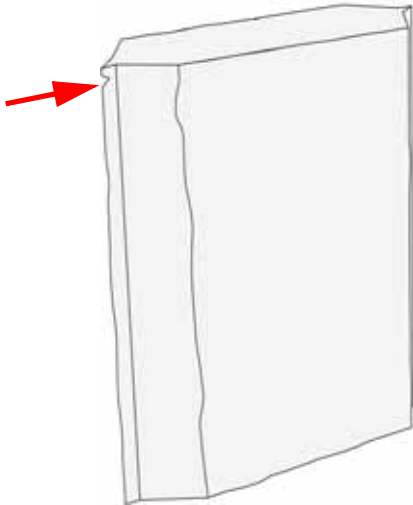

3. Remove the cardboard insert from the top of the QuickPack Print Engine outer bag.

Figure 44 Remove cardboard inserts

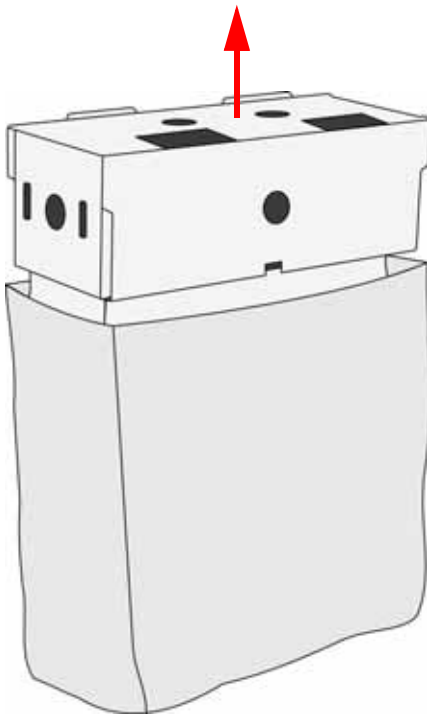

4. Remove the plastic bag containing the tip wipe assembly from the QuickPack Print Engine handle. The tip wipe assembly will be installed in a later step.

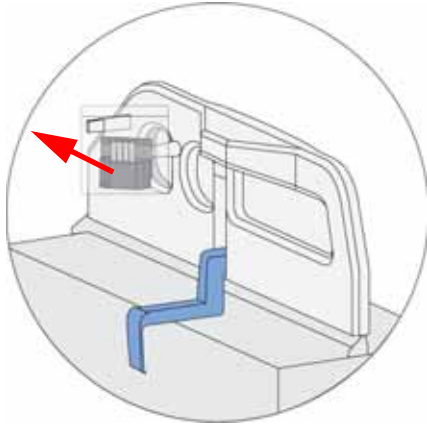

5. Use the handle to remove the QuickPack Print Engine from the bag and remove the orange tape.

Figure 45 Removing the QuickPack Print Engine



6. Place the QuickPack Print Engine material in the appropriate bay. The head must face outside and to the back of the printer.

Figure 46 QuickPack Print Engine placement

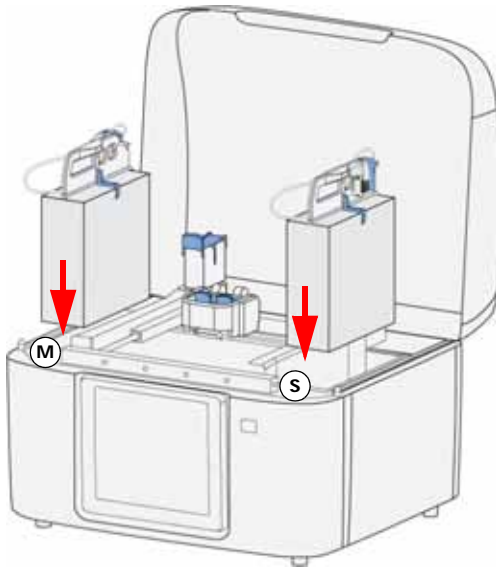

7. Push down on the QuickPack Print Engine to release the locking tab.

Figure 47 Release locking tab

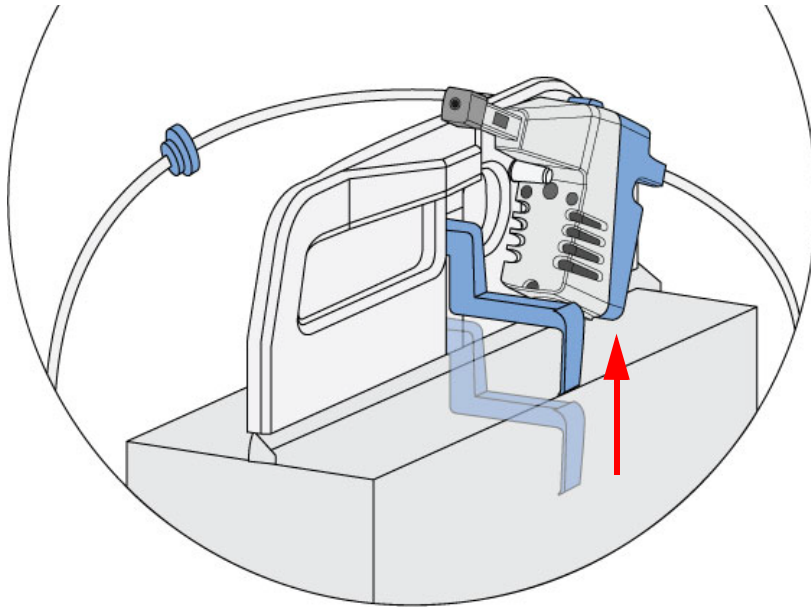

8. Open the appropriate head socket lid by squeezing the tabs together and lifting up.

Figure 48 Open head socket (model head socket shown)

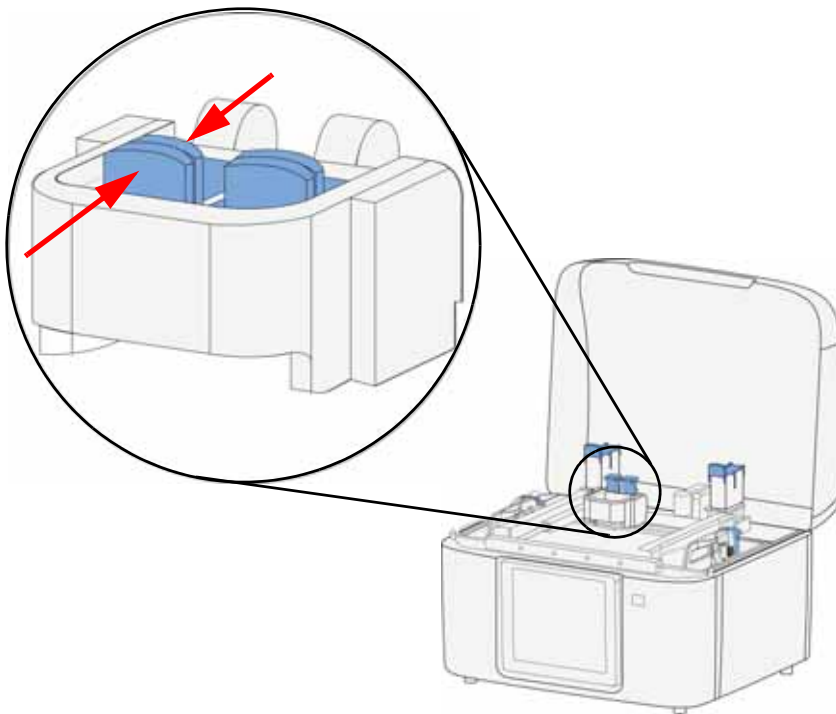

9. Open the appropriate material sensor lid by squeezing the tabs together and lifting up.

Figure 49 Open material sensor lid (model material sensor shown)

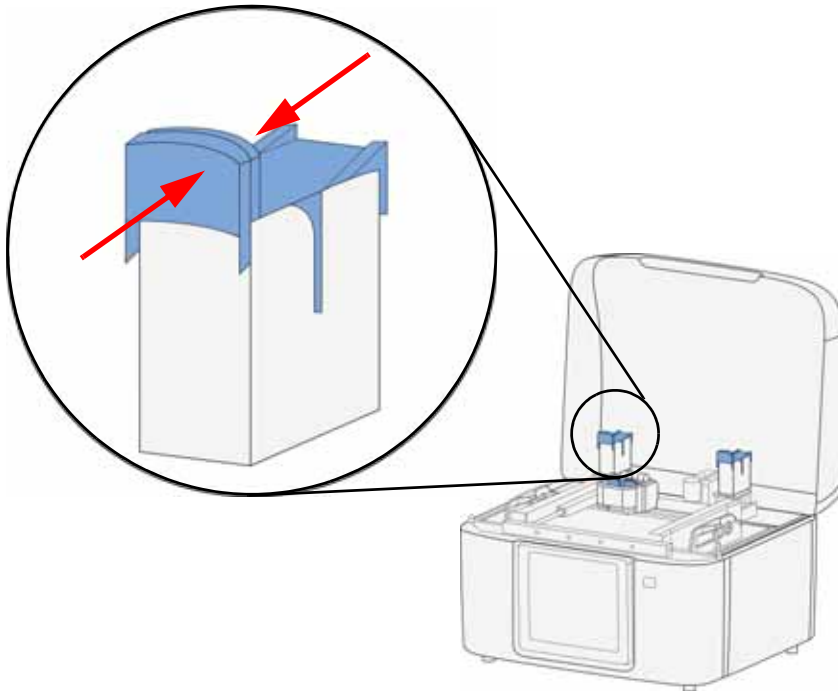

10. Unclip the head from the QuickPack Print Engine handle.

Figure 50 Unclip the head

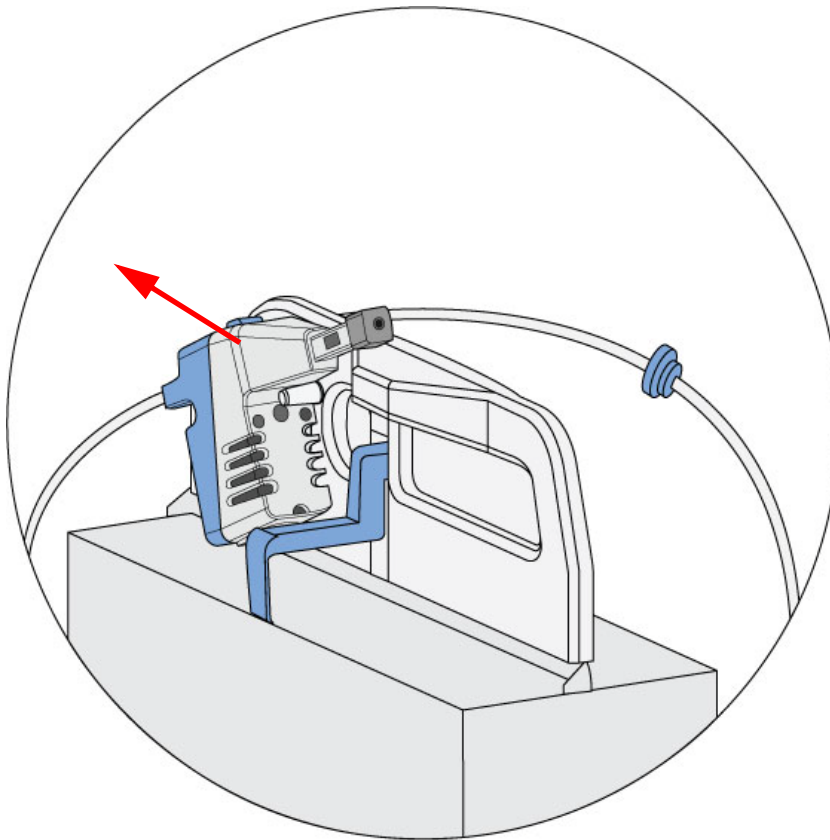

11. Insert the head in the appropriate head socket and close the lid.

Figure 51 Inserting the head (model head shown)

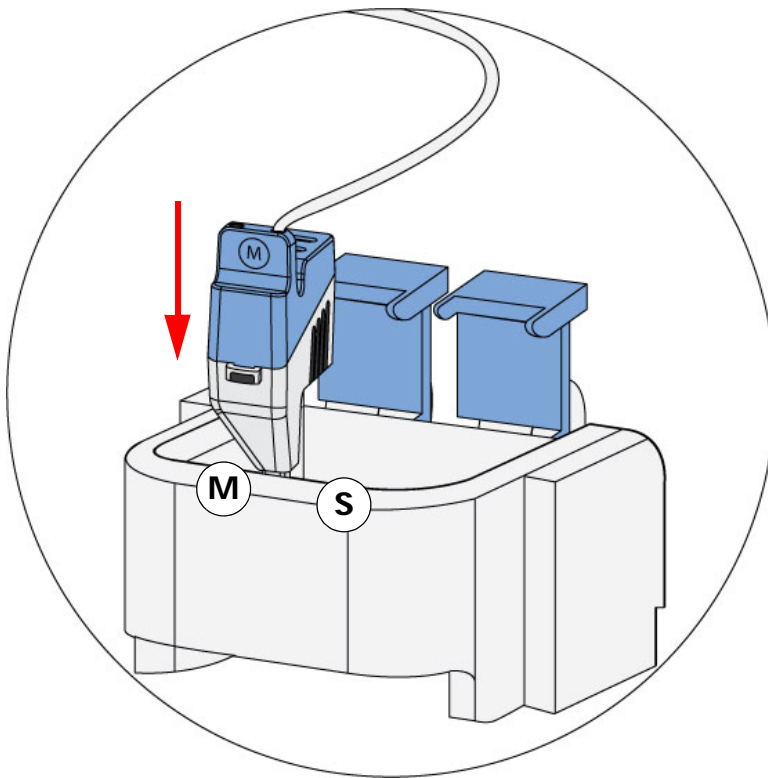

12. Install the model material tube guide into the key in the model material sensor and close the lid. Install the support material tube guide into the key in the support material sensor and close the lid.

Figure 52 Inserting model material

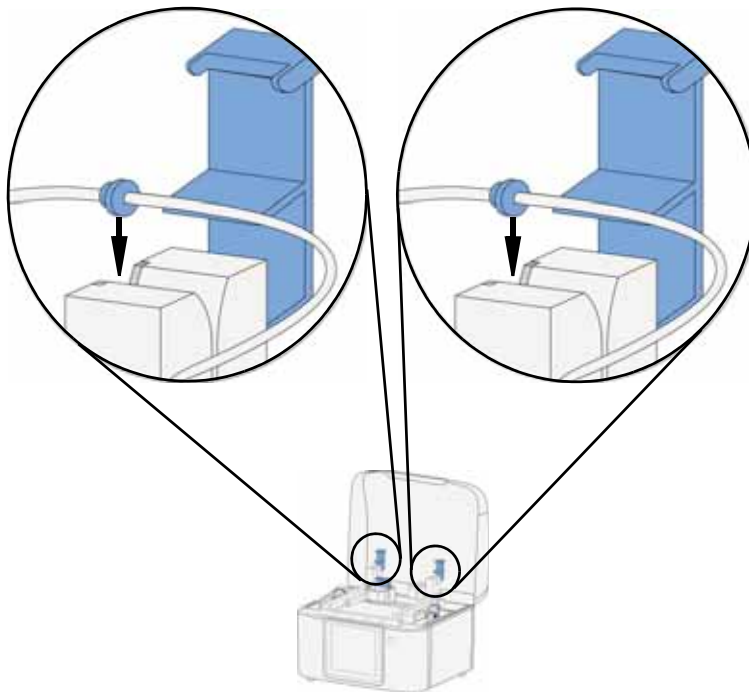

13. Replace the corresponding tip wipe assembly when replacing a QuickPack Print Engine. (See ["Removing and installing tip wipes"](#) on page 44.)

Removing and installing tip wipes



Note: Replace the tip wipe that corresponds to the QuickPack Print Engine (model or support) that is being replaced.

1. Open the door.
2. Remove the tip wipe assembly that corresponds to the QuickPack Print Engine being replaced by lifting the tip wipe up and out of the bracket. There are two tip wipe assemblies; one on either side of the chamber.
3. Place the tip wipe assembly on the two mounting posts on the bracket.
4. Make sure the tip wipe assembly is fully seated in the bracket.

Figure 53 Installing tip wipes (right side shown)

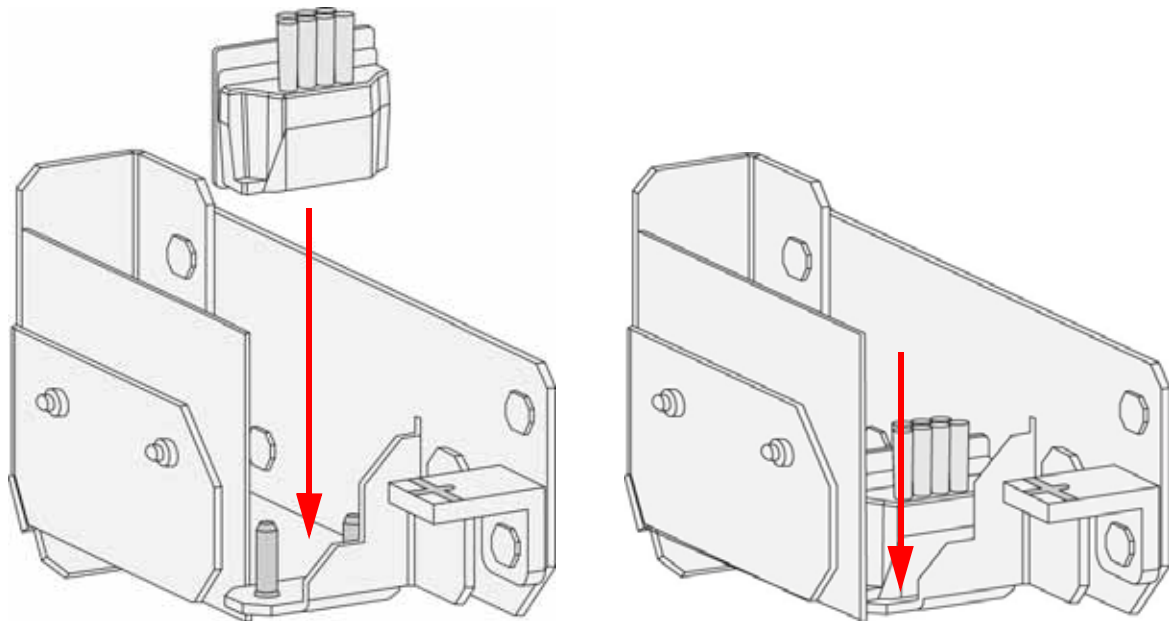

5 Maintenance

Preventive maintenance

Daily

Empty the purge buckets

Empty the purge buckets after each build has completed.

Inspect the tip wipe assembly

After each build you should inspect the tip wipe assembly to make sure there is no material build up. If there is material build up, clean the tip wipe assembly by brushing it off. Material build up on the tip wipe assembly can cause part quality issues.

As needed

Remove debris buildup

Remove all material buildup on the platen and surrounding area. Failure to do so could cause part quality issues.

Clean door

Wipe clean using mild soap and a damp cloth. Do not use ammonia based glass cleaner on the door. It will damage the polycarbonate window.

Replacing tip wipe assembly

The tip wipe assembly should be replaced with each QuickPack Print Engine replacement.

1. Open the door.
2. Lift out the tip wipes out from the holding bracket. There are two tip wipes; one on either side of the chamber.

Figure 54 Removing tip wipes (right side shown)

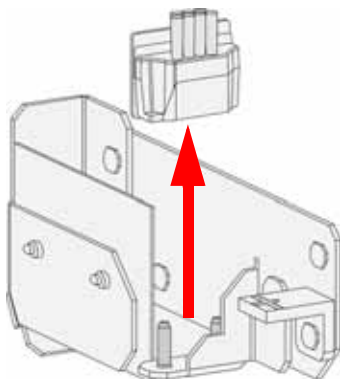

3. When replacing the tip wipes make sure they are fully seated in the holding brackets.

6 Troubleshooting

General

Many printer issues can be resolved by pressing **Resume** in Mojo Control Panel or by cycling power.

Cycling power

1. Turn the printer power switch to the OFF position.
2. The printer will shut off and the LED display will go blank.
3. Wait 20 seconds and turn the power switch to the ON position.
4. The display LEDs will blink in sequence during startup and when complete the display will turn green indicating that the printer is in idle mode.

Cleaning head tips

Occasionally excess material may build up on the head tips. Remove the excess material by gently scraping the head tips using a small flat bladed screwdriver. Use care not to damage the head tips.

Loss of extrusion

Occasionally, the head may experience a loss of extrusion. This will be evident by observing one of the following:

- The head is moving with no material coming out of either tip.
- The height of the model and support materials are not equal.
- Structures are sagging due to lack of material.

If loss of extrusion continues to occur, replace the QuickPack Print Engine.

Extrusion verification

Maintenance purge is a way to verify that a QuickPack is extruding correctly. See [“Maintenance purge” on page 34](#).

Exporting printer file

To better diagnose printer issues, you may need to export the printer configuration file (.cfg) from your printer and send it to your Service Provider.

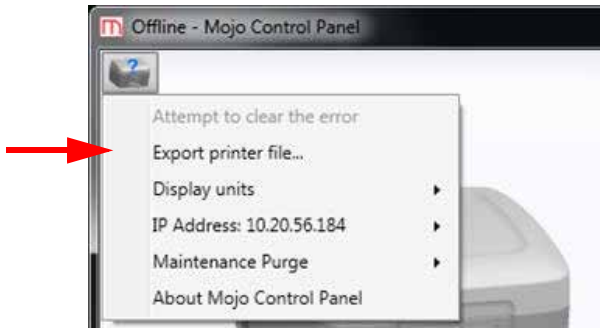

1. Open Mojo Control Panel from the host computer.
2. Click on the printer information icon in the upper left of the window.
3. Select **Export Printer File**.
4. Browse to the directory where you wish to save the configuration file (.cfg).
5. Click the **Save** button.
6. Close Mojo Control Panel.

Troubleshooting

Problem	Recommendation
No power.	<ol style="list-style-type: none">1. Verify power cord is securely connected.2. Verify that the power switch is in the ON position.3. Cycle power (see “Cycling power” on page 46).4. Verify AC power is present at wall outlet.
Material not extruding or under extruding.	<ol style="list-style-type: none">1. Perform a maintenance purge (see “Maintenance purge” on page 34).2. If problem persists, replace the QuickPack Print Engine.
Purge material accumulating on part.	<ol style="list-style-type: none">1. Check condition of tip wipe assembly. Replace if worn.2. Check that tip wipe assembly is properly seated (flush) in the tip wipe bracket.3. Remove tip wipe assembly and check that there is no material on the tip wipe bracket shelf.
Cannot communicate with printer through the USB cable.	<ol style="list-style-type: none">1. Make sure the printer is ON.2. Unplug and reconnect the USB cable connected at the printer and computer.3. Verify the USB cable is not longer than 5 m (197 in.).4. Reboot the host computer.5. If all three LEDs are blinking, cycle power (see “Cycling power” on page 46).6. Reinstall Mojo 3D printer software.7. Swap out the USB cable with another cable.
Cannot read filament (filament sensor).	Make sure the material tube guides are installed correctly in the material sensor assemblies.
Display blinking three colors.	If all three LEDs are blinking, cycle power (see “Cycling power” on page 46).

Warning/fault codes

If a warning/fault occurs which would prevent the printer from operating, the printer will display a code and the action required.

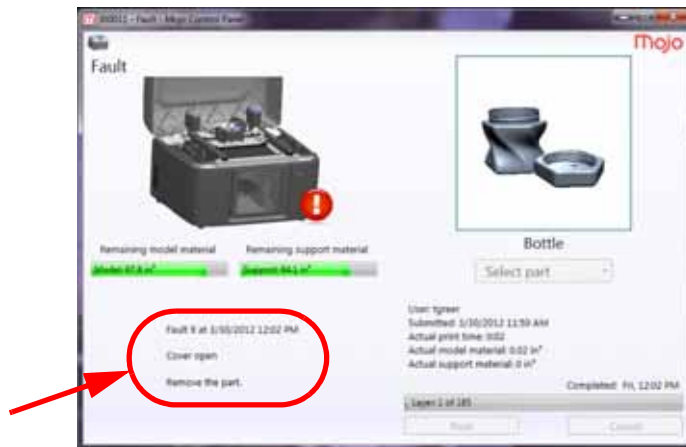

Note: If the error code is not listed below or the printer continues to display an error code, contact your Service Provider.

Fault code chart



Note: Fault codes will cause the part to stop building and the part cannot be recovered.

Fault codes displayed in the Mojo Control Panel	Code Name	Recommendation
8	Door open during build.	Cycle power and restart part.
9	Cover open during build.	Cycle power and restart part.
10	Gantry (U motor) has lost position.	Cycle power and restart part.
11	Gantry (V motor) has lost position.	Cycle power and restart part.
12	Platen (Z motor) has lost position.	Cycle power and restart part.
22	Model heater fault.	Replace model QuickPack Print Engine.
23	Support heater fault.	Replace support QuickPack Print Engine.
31	Model print engine temperature fault.	Replace model QuickPack Print Engine.
32	Support print engine temperature fault.	Replace support QuickPack Print Engine.
51	Printer control error.	Cycle power and restart part.

Warning code chart.



Note: Warning codes will cause the printer to pause during a build. The build may be recovered by pressing **Resume** in Mojo Control Panel.

Warning codes displayed in the Mojo Control Panel	Code Name	Recommendation
100 101	Gantry has lost position.	<ol style="list-style-type: none"> 1. Check for obstructions on the bellows, modeling base and in build chamber. 2. Check that tip wipe assembly is seated properly. 3. Check that the purge bucket is installed correctly.
102	Z motor has lost position.	<ol style="list-style-type: none"> 1. Check for obstructions on modeling base and in the build chamber. 2. Check that the purge bucket is installed correctly.
103	Model print engine following error.	<ol style="list-style-type: none"> 1. Press Resume. 2. If error persists, replace the model QuickPack Print Engine.
104	Support print engine following error.	<ol style="list-style-type: none"> 1. Press Resume. 2. If error persists, replace the support QuickPack Print Engine.
105 106	Gantry motor over current.	<ol style="list-style-type: none"> 1. Check for obstructions on the bellows, modeling base and in build chamber. 2. Check that the purge bucket is installed correctly. 3. Check that the tip wipe assembly is seated properly.
107	Z motor over current.	<ol style="list-style-type: none"> 1. Check for obstructions on the modeling base and in the build chamber. 2. Check that the purge bucket is installed correctly.
108	Model print engine over current.	Replace model QuickPack Print Engine.
109	Support print engine over current.	Replace support QuickPack Print Engine.
112	Model temp over current.	Replace model QuickPack Print Engine.
113	Support temp over current.	Replace support QuickPack Print Engine.
120	Oven temp warning.	Make sure room temperature is between 15°C and 30°C (59 °F and 86°F).
123–140	Low voltages.	Check if AC input power is within specifications (" Facility specifications " on page 55).
148	Head fan current too low.	<ol style="list-style-type: none"> 1. Press Resume. 2. If error persists, contact service provider.
503	Loss of move commands to the printer.	<ol style="list-style-type: none"> 1. Unplug and reconnect the USB cable connection. 2. Cycle power. 3. Reboot host computer. 4. Host computer not within minimum requirements ("Computer specifications" on page 56).

Error code chart



Note: Error codes will cause the printer to pause and not allow the build to start until the error is cleared.

Error codes displayed in the Mojo Control Panel	Code Name	Recommendation
2000	Move compiler error.	<ol style="list-style-type: none"> 1. Cycle power and reboot host computer. 2. Reinstall 3D printer software.
2001	Printer not connected.	<ol style="list-style-type: none"> 1. Verify USB cable is connected. 2. Verify the USB cable is not longer than 5 m (197 in.). 3. Unplug and reconnect the USB cable connection. 4. Cycle power. 5. Reboot host computer. 6. Host computer not within minimum requirements (“Computer specifications” on page 56).
2002	File not found.	Reprocess STL file.
2003	Disk full.	Host computer hard drive is full. Free disk space on host computer.
2005	Door open.	Close door.
2006	Cover open.	Close cover.
2007	Model print engine not installed in printer.	Install model QuickPack Print Engine.
2008	Support print engine not installed in printer.	Install support QuickPack Print Engine.
2009	No response from printer.	<ol style="list-style-type: none"> 1. Verify that USB cable is connected. 2. Cycle power (see “Cycling power” on page 46) and computer power. 3. Reinstall Mojo 3D printer software.
2019	Modeling base missing.	Install new modeling base.
2020	Modeling base not level.	Replace modeling base.
2028	Homing failed.	Check for obstructions on the modeling base and in chamber.
2032	Model print engine not heating.	Replace model QuickPack Print Engine.
2033	Support print engine not heating.	Replace support QuickPack Print Engine.
2035	Calibration timed out.	Clean head tips (see “Cleaning head tips” on page 46).
2037	Printer firmware version is newer than PC software version.	Reinstall Mojo 3D printer software.
2038	Fault while USB is disconnected.	<ol style="list-style-type: none"> 1. Verify that USB cable is connected. 2. Cycle power (see “Cycling power” on page 46) and computer power.
2039	Pause while USB is disconnected.	<ol style="list-style-type: none"> 1. Verify that USB cable is connected. 2. Cycle power (see “Cycling power” on page 46) and computer power.

Error codes displayed in the Mojo Control Panel	Code Name	Recommendation
2041	Tip offset calibration failed on model tip.	<ol style="list-style-type: none"> 1. Clean head tips (see "Cleaning head tips" on page 46). 2. Replace model QuickPack Print Engine.
2042	Tip offset calibration failed on support tip.	<ol style="list-style-type: none"> 1. Clean head tips (see "Cleaning head tips" on page 46). 2. Replace support QuickPack Print Engine.
2043	Spool lock detected on model spool.	Release locking tab on model material QuickPack Print Engine.
2044	Spool lock detected on support spool.	Release locking tab on support material QuickPack Print Engine.
2045	Printer firmware version is older than PC software version.	Select the "Attempt to clear the error" menu item in the Mojo Control Panel to update printer firmware version to match the PC software version. (This takes approximately 2 minutes.)

7 Support

Registration

To register your Mojo 3D printer, visit:

<http://www.mojo3dprinting.com/help/register-printer.aspx>.

Customer support

Visit: <http://www.stratasys.com/login> for the following:

- Material specifications, MSDS, and environmental documentation.
- Product specifications and guides.
- Applications.
- Best practices.

When contacting technical support please provide the following:

By phone:

- System model.
- System serial number.
- System software build number.
- Mojo 3D Printer software and Print Wizard software version numbers.
- Detailed description of the problem you are experiencing.
- If possible, try to be near the printer for troubleshooting, if possible.

By email:

- System model.
- System serial number.
- Your name.
- Your telephone number.
- Detailed description of the problem you are experiencing.

For advanced troubleshooting (provide by email):

- System CFG file.
- STL and/or CMB files.
- Detailed photographs showing the issue.

8 Recycling

Recycle all materials per your local recycling guidelines.

Figure 55 Recycling Codes

System Component	Materials	Recycling Code
Modeling bases	ABS	

All packaging materials can be recycled per your local recycling guidelines.



Note: Go to stratasys.com/recycling for information on recycling QuickPack Print Engines in your region.

Follow your local recycling guidelines when recycling electronic components.

9 Printer Specifications

Physical specifications

Height	47 cm (18.5 in.)
Width	63 cm (25 in.)
Depth	52.1 cm (20.5 in.)
Weight	28.2 kg (62 lbs)

Facility specifications

Installation location	Stable flat surface capable of holding 34.1 kg (75 lbs), with a height clearance of 80 cm (31.5 in.).
Power Requirements	6A @ 100-127VAC or 2.5A 220-240VAC -- 50/60Hz 600W dedicated circuit within 2 m (80 in.) Do not use an extension cord or a power strip. Using these can possibly cause intermittent power issues.
Air Circulation	165.1 mm (6.5 in.) minimum space behind printer for air circulation. 50.8 mm (2 in.) minimum space around printer for air circulation.

Computer specifications

Operating System	Minimum: Microsoft Windows 7 (SP1, 32- or 64-bit), Windows 8 (32- or 64-bit) Recommended: Windows 7 (SP1, 64-bit) or Windows 8 (64-bit)
Processor	Minimum: Intel® or AMD® dual-core, 2.0 GHz or greater Recommended: Intel® Core™ i5 (quad core) 3GHz or greater
RAM	Minimum: 2GB Recommended: 4GB
Hard Disk	Minimum: 11GB disk space available Recommended: 15GB space available
Video display adapter	Minimum: 1024x768 or greater resolution at 96 dpi, 1280x 800 or greater at 120 dpi, 128MB or greater memory, support for DirectX 9.0 or greater. Recommended: 1680x1050 or greater resolution, 256MB or greater memory, or integrated Intel HD graphics, support for DirectX 9.0 or greater.
USB	Minimum: One USB 2.0 or USB 3.0 port Recommended: One USB 2.0 port or USB 3.0 port USB cable maximum length: 5 m (197 in.)

Power specifications

Source (nominal)	6A 100-127VAC or 2.5A @ 220-240VAC -- 50/60Hz 600W dedicated circuit within 2 m (80 in.) Do not use an extension cord or a power strip. Using these can possibly cause intermittent power issues.
------------------	--

Environmental specifications

Temperature range	15 °C to 30 °C (59 °F to 86 °F)
Relative humidity range	20% to 80% RH non condensing
Heat emission	1057 BTU/hr (typical building) 85 BTU/hr (typical at idle)

Acoustic specifications

Idle sound pressure at bystander	<32 dBA (idle)
Operating sound pressure at bystander	<46 dBA (printing)

10 Supplemental Information

Stratasys limited warranty statement

Stratasys, Inc. ("Stratasys") warrants its' systems and associated peripheral devices and replacement parts (collectively, the "Product") purchased from Stratasys or an Authorized Stratasys Reseller to be free from defects in material and workmanship according to the terms and conditions stated below:

Warranties extend only to the original purchaser of the Product. The warranty on the original Product, as delivered, extends for one year starting on the date of delivery. Your sole remedy as purchaser under this Limited Warranty shall be repair or replacement as provided herein.

To preserve your warranty rights, Products must be installed in accordance with the then-current User Guide available at www.stratasys.com. During the Limited Warranty period, Stratasys or its' designated representative will, at their option, repair or replace a defective Product as set forth below. Service Parts and replacement Products will be furnished on an exchange basis, and will be either new or refurbished. All replaced parts or replaced Products become the property of Stratasys, and you will be invoiced for replacement parts if defective parts are not returned as directed by Stratasys under this Limited Warranty.

Stratasys will bear the cost of returned parts, as well as for shipping new or rebuilt replacement parts to you, provided that you report the warranty claim within the Limited Warranty period and obtain return instructions from Stratasys prior to return. Replacement parts independently carry a 90-day warranty from date of shipment from Stratasys or designated representative location. Consumable parts are not covered by this Limited Warranty. Warranty services may be provided by Stratasys, an Authorized Reseller, or a third party service provider designated by Stratasys.

No coverage or benefits under this Limited Warranty will exist if any of the following conditions apply:

- (a) The Product has been subjected to abnormal use, improper or inadequate maintenance, unauthorized modifications, unauthorized repair, misuse, abuse, exposure to moisture, flooding, fire, electrical problems associated with incoming power, or other acts which are not the fault of Stratasys, Inc.
- (b) Stratasys' Customer Service Department was not notified of the defect or malfunction of the system prior to expiration of the one year warranty period.
- (c) Parts or consumables were installed and used that were not certified or approved by Stratasys.

Stratasys will also not be liable under any circumstances for Product replacement or associated labor, loss of use, loss of profits, or for any other indirect, incidental, collateral, exemplary, punitive, consequential or special damages, or losses arising out of the purchase of the Product and/or out of this limited warranty, even if Stratasys or its' designated representative have been advised of the possibility of such damages or claims. To the extent such claims are not excludable as adjudged by a court of competent jurisdiction, you agree to accept as sole and exclusive remedy, a payment equal to the original purchase price for the product adjudged to be defective.

SOME COUNTRIES, REGIONS, STATES OR PROVINCES DO NOT ALLOW THE EXCLUSION OR LIMITATION OF REMEDIES OR OF INCIDENTAL, PUNITIVE, OR CONSEQUENTIAL DAMAGES, OR THE APPLICABLE TIME PERIODS, SO THE ABOVE LIMITATIONS OR EXCLUSIONS MAY NOT APPLY TO YOU. EXCEPT TO THE EXTENT LAWFULLY PERMITTED, THIS LIMITED WARRANTY DOES NOT EXCLUDE, RESTRICT OR MODIFY, AND IS IN ADDITION TO THE STATUTORY RIGHTS APPLICABLE TO THE SALE OF THIS PRODUCT TO YOU.

This warranty gives you specific legal rights and you might also have other rights that vary from country/region to country/region, state to state, or province to province.

EXCEPT FOR THIS LIMITED WARRANTY, AND TO THE FULLEST EXTENT ALLOWED BY LAW, NEITHER STRATASYS NOR ANY AUTHORIZED RESELLER MAKES ANY OTHER WARRANTY OF ANY KIND, EXPRESS OR IMPLIED, INCLUDING ANY IMPLIED WARRANTY OF MERCHANTABILITY OR FITNESS FOR A PARTICULAR PURPOSE. STRATASYS DOES NOT OFFER, ASSUME OR AUTHORIZE THE OFFER OR ASSUMPTION OF LIABILITY FOR IT OR FOR ANY OTHER WARRANTY, EITHER EXPRESS OR IMPLIED BY ANY AUTHORIZED RESELLER OR OTHER INDEPENDENT THIRD PARTY.

Declaration of conformity



Declaration of Conformity

Manufacturer: Stratasys Inc.
7665 Commerce Way
Eden Prairie, MN 55344-2080

EU Representative: Andy Middleton

Type of Equipment: 3D Printer

Model Numbers: 690-10000 Mojo™ 3D Printer

We declare under our sole responsibility that the devices mentioned above comply with the following EU Directives:

RoHS: 2011/65/EU
Electromagnetic Compatibility (EMC): 2004/108/EC
Machinery: 206/42/EC
Low Voltage: 2006/95/EC

Common Technical Specifications used for demonstration of compliance: EN55022:2010
EN60950-1: 2006
EN55024:2010
EN61000-4-2: 2009
EN61000-4-3: 2006 + Amendments A1: 208 + A2: 2010
EN61000-4-4: 2004 + Corrigendum 2008
EN61000-4-5: 2006
EN61000-4-6: 2009
EN61000-4-8: 2010
EN61000-4-11 Second Edition: 2004:

Date of Validity: February 1, 2013

Authorized Address: Stratasys Inc.
7665 Commerce Way
Eden Prairie, MN 5534-20804

Stratasys GmbH
Airport Boulevard B 210,
77836 Rheinmunster
Germany

Name of Authorized Signatory: Mary Stanley

Andy Middleton

Position Held in Company: Product Manager

General Manager E, ME, A

Signatures:

Handwritten signature of Mary Stanley in black ink.

Handwritten signature of Andy Middleton in black ink, enclosed in a large, hand-drawn oval.

Regulatory and environmental information

EMC Class A Warning



WARNING: This is a Class A product. In a domestic environment this product may cause radio interference in which case the user may be required to take adequate measures.

FCC Statements (U.S.A.)

The U.S. Federal Communications Commission (in 47 cfr1 5.105) has specified that the following notices be brought to the attention of users of this product.

This device complies with part 15 of the FCC rules. Operation is subject to the following two conditions:(1) this device may not cause harmful interference, and (2) this device must accept any interference received, including interference that may cause undesired operation.

Shielded cables: use of shielded data cables is required to comply with the Class A limits of Part 15 of the FCC Rules.

Caution: Pursuant to Part 15.21 of the FCC Rules, any changes or modifications to this equipment not expressly approved by Stratasys, Ltd. may cause harmful interference and void the FCC authorization to operate this equipment.

Note: This equipment has been tested and found to comply with the limits for a Class A digital device, pursuant to Part 15 of the FCC Rules. These limits are designed to provide reasonable protection against harmful interference in a commercial environment. This equipment generates, uses and can radiate radio frequency energy and, if not installed and used in accordance with the instructions, may cause harmful interference to radio communications. Operation of this equipment in a residential area is likely to cause harmful interference, in which case the user will be required to correct the interference at their own expense.

Canada Electromagnetic compatibility (EMC)

Normes de sécurité (Canada)

Le présent appareil numérique n'émet pas de bruits radioélectriques dépassant les limites applicables aux appareils numériques de Classe **A** prescrites dans le règlement sur le brouillage radioélectrique édicté par le Ministère des Communications du Canada.

DOC statement (Canada)

This digital apparatus does not exceed the Class **A** limits for radio noise emissions from digital apparatus set out in the Radio Interference Regulations of the Canadian Department of Communications.

MSDS (Material Safety Data Sheet)

You can obtain current Material Safety Data Sheets for the material used in the printer is available at: <http://www.stratasys.com/login>.

Disposal of waste equipment by users in private households in the European Union



This symbol on the product or on its packaging indicates that this product must not be disposed of with your other household waste. Instead, it is your responsibility to dispose of your waste equipment by handing it over to a designated collection point for the recycling of waste electrical and electronic equipment. The separate collection and recycling of your waste equipment at the time of disposal will help to conserve natural resources and ensure that it is recycled in a manner that protects human health and the environment. For more information about where you can drop off your waste equipment for recycling, please contact your local city office, your household waste disposal service or the shop where you purchased the product.

11 Glossary

Glossary of terms

Host computer

The host computer is defined as the computer where the Mojo 3D printer software and optional Print Wizard software reside. The host computer is directly connected to the Mojo printer through a USB cable.

Job

One or more files that have been sent to a Mojo printer.

Local printer

A Mojo printer attached to the computer where the computer 3D printer software is running.

Pack

A pack consists of one model or many models. A pack contains information about the location of single or multiple files within the build chamber.

Part

A three dimensional object to be printed on a Mojo printer.

STL file

STL files are described as only the surface geometry of a three dimensional object (part) without any representation of color, texture or other common CAD model attributes. An STL file contains the surface shape of the part to be printed.

XYZ-axes

When referring to a three-dimensional plane, a Z-axis refers to the vertical height of a three-dimensional object. The Z-axis plane goes top to bottom and intersects with the Y-axis and X-axis. The X-axis refers to the horizontal width and the Y-axis refers to the depth of a two or three-dimensional object.