

Cascade Microtech, Inc.

SPECIFICATION SHEET

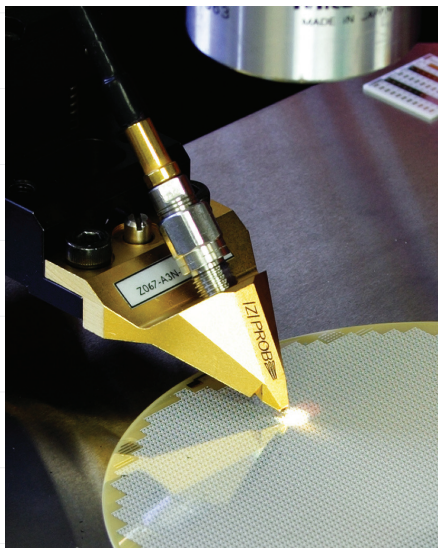

Maximum performance
up to 67 GHz

IZI PROBE®

High-Frequency Wafer Probe (67 GHz)

For wafer-level test of RF and microwave devices, there is no better solution than Cascade Microtech's IZI Probe. The patented technology used in the IZI Probe assures high-accuracy measurements with low contact resistance and superior impedance control. The RF/microwave signal makes only one transition to the coplanar contact structure within the shielded, air-isolated probe body. This maintains the signal integrity with stable performance over a wide temperature range.

With the revolutionary 1MX™ technology, the IZI Probe 67 GHz provides superior electrical performance, especially insertion and return loss. In addition, isolation (crosstalk) has been significantly improved resulting in a probe that delivers the highest accuracy for your wafer-level RF and microwave measurements.

Contacting the device under test (DUT) with the IZI Probe is simple, highly repeatable and requires minimum overtravel. Additionally, the contacts can move independent of each other, allowing you to probe on three-dimensional structures and on wafers with pad-height deviation of up to 50 µm.

Used in conjunction with Cascade Microtech's HF probing system including ProbeHeads™, powerful SussCal® Calibration Software and highly-accurate CSR family of calibration substrates, the IZI Probe becomes the ultimate tool for all your HF wafer-level probing needs.

Thanks to the proven IZI Probe technology, the probe also has an extremely long lifetime. It guarantees a useful life of at least 1,000,000 contact cycles under standard use and overtravel.

FEATURES AND BENEFITS

Durability	Incredibly long lifetime
	Unparalleled repeatable and reliable contact quality
	Suitable for automated testing
Flexibility	Probe on most pad material with minimal damage
	Independent, long contact springs easily overcome pad height differences up to 50 µm
	Small structures such as 40 µm x 40 µm pads can be tested
	Excellent performance in vacuum environments and temperatures from 10 K to 300°C
RF performance	Low contact resistance
	New 1MX technology ensures low insertion loss, high isolation and accurate measurements

SPECIFICATIONS*

Electrical Characteristics

Characteristic impedance	50 Ω
Frequency range	DC to 67 GHz
Return loss	> 17 dB DC to 67 GHz**
Insertion loss	< 1.0 dB DC to 67 GHz**
Maximum RF power	4 W at 67 GHz, 9 W at 20 GHz, 16 W at 5 GHz
Maximum DC current	1.5 A
Maximum DC voltage	100 V
Contact resistance on Au	< 4 m Ω **

Mechanical Characteristics

Contacts	Solid nickel springs
Insulator	RF dielectric
Contact cycles on Al	> 1,000,000
Contact spring pressure	4 N/mm
Available standard pitches	50 μm to 200 μm with 25 μm increments, 200 μm to 250 μm with 50 μm increments

RF Connector

Type	PC 1.85 mm, female
Coupling torque	0.8 Nm to 1.1 Nm (Recommended)
Outer contact	Stainless steel
Center contact	CuBe with Au plating
Insulator	PEEK

Environmental Data

Temperature range	-100 $^{\circ}\text{C}$ to 200 $^{\circ}\text{C}$ (Type V, standard), 10 K to 300 $^{\circ}\text{C}$ (Type C, extreme temperature)
-------------------	--

*Data, design and specification depend on individual process conditions and can vary according to equipment configurations.

Not all specifications may be valid simultaneously.

**Typical for probes with pitches from 50 μm to 150 μm

PHYSICAL DIMENSIONS

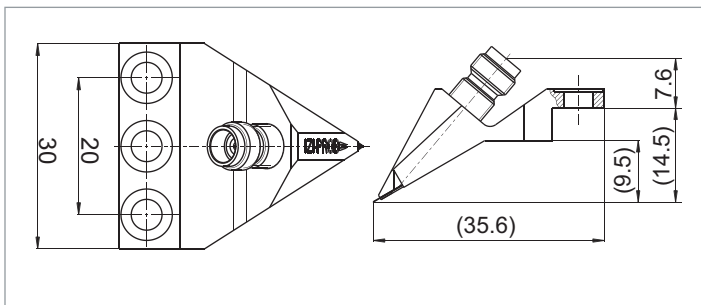

[Z] Probe standard case (all dimensions in mm).

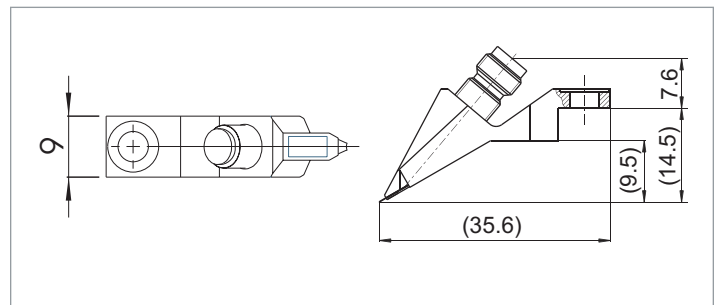

[Z] Probe slim case (all dimensions in mm).

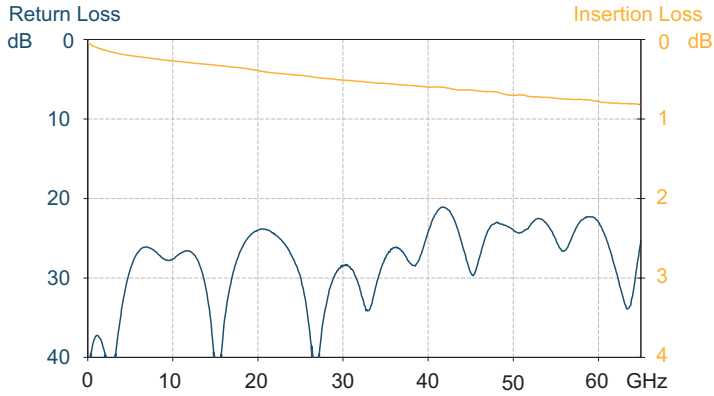

Uncalibrated performance of a IZI Probe 67 V3N GSG 150.

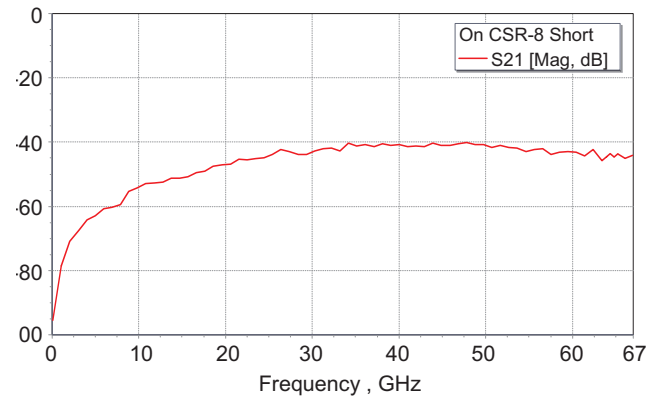

Signal isolation (crosstalk) of two IZI Probes separated by a distance of 150 μ m.

Long lifetime of IZI Probe (Contact material: Al Overtravel: 75 μ m)

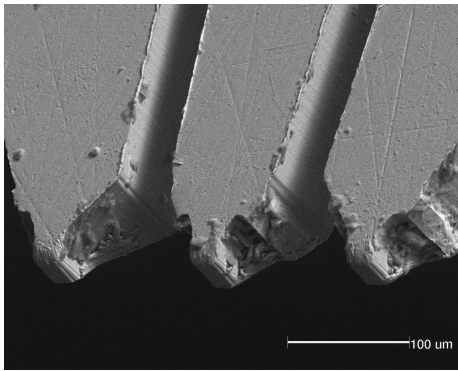

New IZI Probe (upside-down).

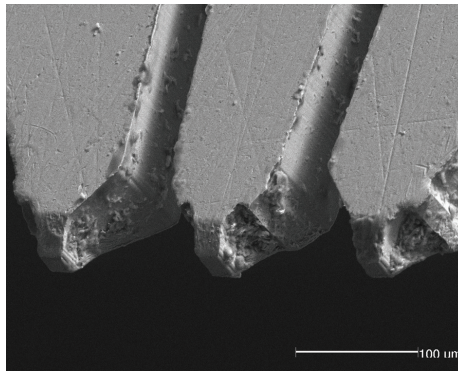

The same probe after 1.5 million touchdowns.

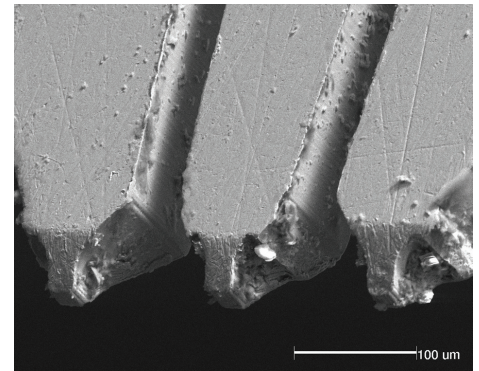

The same probe after three million touchdowns.

© Copyright 2010 Cascade Microtech, Inc.
All rights reserved. Cascade Microtech, SussCal and IZI Probe are registered trademarks and IMX and ProbeHead are trademarks of Cascade Microtech, Inc. All other trademarks are the property of their own respective owners.

Data subject to change without notice

ZProbe67-SS-0310

Cascade Microtech, Inc.
toll free: +1-800-550-3279
phone: +1-503-601-1000
email: cmi_sales@cmicro.com

Cascade Microtech GmbH
phone: +49-811-60005-0
email: cmg_sales@cmicro.com

Cascade Microtech Japan
phone: +81-3-5615-5150
email: cmj_sales@cmicro.com

Cascade Microtech Shanghai
phone: +86-21-3330-3188
email: cmc_sales@cmicro.com

Cascade Microtech Singapore
phone: +65-6873-7482
email: cms_sales@cmicro.com

Cascade Microtech Taiwan
phone: +886-3-5722810
email: cmt_sales@cmicro.com