

# PA200 BlueRay

## 200 mm Semi-automated Probe System with BlueRay Technology



### DATA SHEET

The PA200 BlueRay™ sets a new standard for high-speed accuracy. Its precision ensures smooth probe landing with safe, repeatable electrical contact. In combination with the unique Z-profiling function, even extreme variation in height, such as the case with warped wafers, can be compensated. This test approach reduces pad damage and easily allows devices to be bonded after testing, even with the thinnest of pads.

Cascade Microtech recognizes that flexibility and modularity are the keys to addressing your production testing needs and we have created a solution that scales with your requirements. As the throughput demands increase, an optional wafer-handling robot specifically designed for the PA200 BlueRay can be docked onto the prober. This upgrade to a fully-automated system is done in the field.

With the Velox™ probe station control software, the PA200 BlueRay enables easy on-screen navigation, wafer mapping, seamless integration with analyzers and measurement software, and simple operation of motorized positioners. The VeloxPro™ test automation software (optional) is an open-architecture automation tool for fully-automated wafer probing. Compliant with SEMI E95, the VeloxPro easily enables automated wafer handling, cassette mapping, Z-profiling and stepping. The PA200 BlueRay, powered by Velox and VeloxPro, achieves easy test automation and high test throughput.

### FEATURES / BENEFITS

High throughput	Up to 20 dies/sec. (70,000 dies/hour) with MultiDie™ test technology Eight positioning steps per second without compromising accuracy Highest Z-axis resolution of any production prober
Modularity	Wafer-handling robot can be docked onto prober Easy integration and test automation using Velox and VeloxPro
Cost effectiveness	Interfaces to all major analysis instrumentation, optics software and testers Smallest footprint Upgradeable in the field Low cost of ownership Fast return on investment Scales with your requirements

## MECHANICAL PERFORMANCE

### X-Y Stage

Travel	205 mm x 205 mm (8.07 in. x 8.07 in.)
Resolution	0.5 $\mu\text{m}$ (0.02 mils)
Repeatability	$\pm 2 \mu\text{m}$ (0.08 mils)
Accuracy	$\pm 5 \mu\text{m}$ (0.12 mils)
Bearings	Precision linear cross-roller
Motor-drive system	DC servo motors
Feedback system	Closed-loop optical linear encoder

### Z Stage

Travel	15.0 mm (0.39 inch)
Resolution	0.25 $\mu\text{m}$ (0.01 mils)
Repeatability	$\pm 1 \mu\text{m}$ (0.04 mils)
Accuracy	$\pm 2 \mu\text{m}$ (0.04 mils)

### Theta Stage

Travel	$\pm 6^\circ$
Resolution	0.0001 $^\circ$
Accuracy of standard moves	$<2 \mu\text{m}$ (0.08 mils)*

\*Measured at edge of 200mm chuck

## PHYSICAL DIMENSIONS

### Station Platform

Station dimensions (with table)*	700 mm (W) x 800 mm (D) x 1400 mm (H) (27.6 in. x 31.5 in. x 55.0 in.)
Platen-to-eyepieces (optional)	220 mm
Weight (with table)	320 kg (705 lb.)

\*See drawings for detailed dimensions

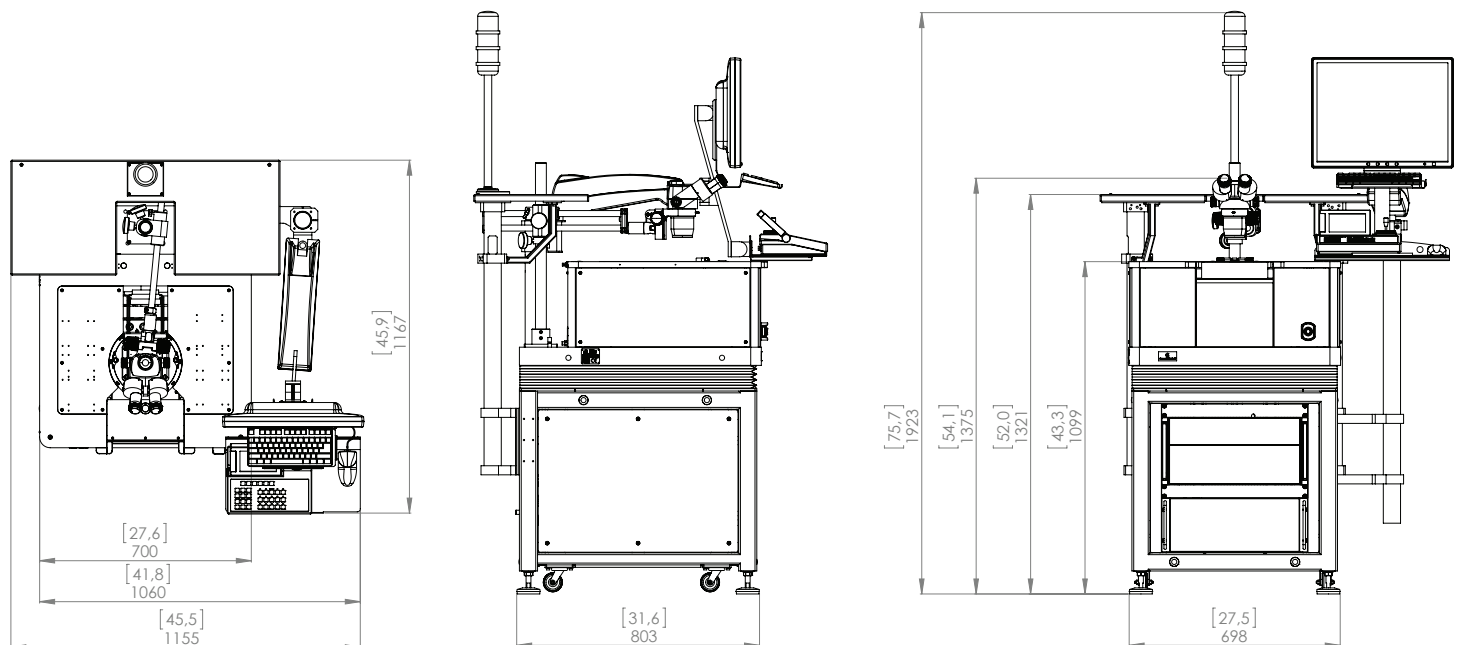

## PHYSICAL DIMENSIONS

### Station with Optional Robot Handler

Station dimensions*	1150 mm (W) x 885 mm (D) x 1455 mm (H) [45.3 in. x 34.8 in. x 57.3 in.]
Weight	520 kg (1146 lb.)

\*See drawings for detailed dimensions

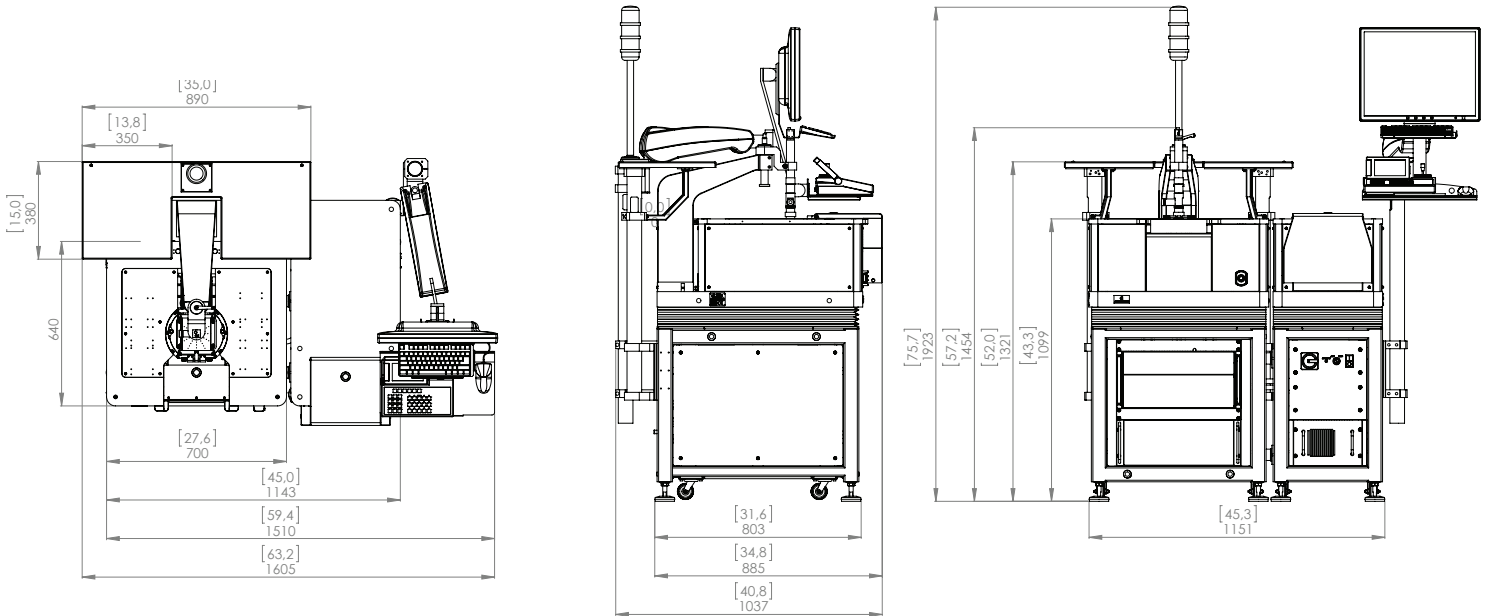

## PLATEN SYSTEM

Material	Aluminum with steel inserts for magnetic, vacuum and bolt-down positioners available
Dimensions	700 mm (W) x 640 mm (D) [27.6 in. x 25.2 in.]
Platen-to-chuck height	32.0 ± 0.5 mm [1.26 ± 0.02 inch]
Lift range	Fixed
Lift repeatability	Not applicable
Accessory compatibility	Minimum of eight DC or four RF positioners allowed, compatible simultaneous probe card holder use

## PLATFORM

The PA200 BlueRay features the Velox probe station control software, and also can be equipped with VeloxPro user interface for test automation (optional).

### Velox Probe Station Control Software

Velox software provides all features and benefits required for semi-automated operation of the probe system, such as:

- WaferMap with Z-profiling, sub-die stepping, binning and other useful features
- Configurable user interface and programmable buttons
- Cleaning routines for probe cards and probe tips

### VeloxPro Test Automation Software (Optional)

The PA200 BlueRay can be equipped with the VeloxPro user interface for test automation and automated wafer handling, featuring:

- Compliance to SEMI E95
- Screens for the setup of new recipes, parameters and pattern recognition
- Cassette mapping and map visualization capabilities, with statistics and status view
- Test sequence customization
- Ability to load new wafers into the cassette while test is running on the chuck
- Capability to accommodate multiple types of wafers in one cassette
- Ability to load any wafer out of any cassette to any system chuck

### Tester Interface

The PA200 BlueRay uses commands through GPIB/TCPIP as master or slave. The GPIB/TCPIP interface provides:

- Request an inventory of all wafers available in the cassettes
- Define a wafer map
- Define a job (out of wafers and recipe)
- Receive notifications when the wafer is aligned and ready to test

### Communication Ports

Type	Qty	Location	Notes
LAN	1	Rear system controller	
USB 2.0	2 + 4	Front and rear system controller	For USB drives, security keys and USB instrument control
RS232	2	Rear system controller	For instrument control (wafer handler, LASER, microscope illumination, etc.)
GPIB IEEE 488.2	1	Rear system controller	For test instrument control (optional)

### Accessory Interface Ports

EDGE	2	Connection panel at rear of platen	Probe card contact sense
INKER	2	Connection panel at rear of platen	Control for die inker
AUX Power	4	Rear system table	IEC connectors for additional measurement instrumentation

## NON-THERMAL CHUCKS

Diameter	200 mm
Material / Surface	Stainless steel with micro-hole patterns for compatibility with RF devices and thin wafers
AUX chucks	2 auxiliary locations for use with ISS, contact or cleaning substrate
DUT sizes supported	Single dies >4 mm, shards or wafers 50 mm (2 in.) through 200 mm (8 in.)
Vacuum rings	50 mm, 100 mm, 150 mm, 200mm (2 in., 4 in., 6 in., 8 in.)
Vacuum-ring actuation	Three zones, controlled by software
Planarity	<10 µm

## THERMAL CHUCKS

Diameter	200 mm
Material/ Surface	Nickel coated surface with grooved vacuum rings
AUX chucks	Optionally one or two isolated auxiliary locations for use with ISS, contact or cleaning substrate
DUT sizes supported	Shards or wafers 50 mm (2 in.) through 200 mm (8 in.)
Vacuum rings	50 mm, 100 mm, 200 mm (2 in., 4 in., 8 in.)
Vacuum-ring actuation	Three zones, controlled by software

## THERMAL SYSTEM PERFORMANCE

Note: Results measured with thermal chuck at standard probing height with chuck in a dry environment. Moisture in the chuck may degrade performance.

### Coaxial ATT Hot Chuck System A200

Temperature range	25°C – 150°C
Transition time – Heating (25°C to 150°C)	<10 min
Transition time – Cooling (150°C to 25°C)	<8 min
Thermal uniformity (25°C to 150°C)	< ± 0.5 K
Thermal uniformity (>100°C)	< ± 0.5%
Temperature accuracy	± 0.5°C
Supply voltage	110/230 VAC 50/60 Hz
Temperature control	Integrated with Velox

## MACHINE TABLE

Anti-vibration damping	Basic with polymer dampers or compressed air dampers with leveling
Table rack	For hosting system controller, electronics box and microscope accessories

## FACILITY REQUIREMENTS

Note: see the Station Facility Guide for complete information

Power	Single phase 110/230 V, 50/60 Hz, 600 W (maximum 1500 VA, depending on tool configuration)
Vacuum	<200 mbar abs., 8 mm hose
Compressed air	4 bar minimum, 8 mm hose
Background vibrations	“Operating Theater” level (as specified by ISO)

## WAFER-HANDLING ROBOT (OPTION)

Supported cassettes	One SEMI E1 cassette ("H" bar design)
Supported wafers	2"– 4", 3"– 8" depending on robot configuration
Substrate handling	Vacuum horseshoe end effector at substrate bottom side
Cassette indexing	Single beam laser reflection scanner
Pre-aligner	Optical sensing, compatible with notch / flats
Scan time	<6 sec.
Load time (including pre-alignment)	<30 sec.

## STATION ACCESSORIES

Measurement shelf	Two places for instruments each 350 mm (W) x 380 mm (D) (13.8 in. x 15.0 in.), 30kg supporting weight
Dark enclosure	EMI shielding, light tight enclosure SE1000 (not with robot module)
Operation lamp	Software controllable, red, yellow, green
Control console	Adjustable arm, holding display, keyboard, mouse and joystick

## REGULATORY COMPLIANCE

Certification	CE, Semi S2
---------------	-------------

## WARRANTY

Warranty*	Fifteen months from date of delivery or twelve months from date of installation
Service contracts	Single and multi-year programs available to suit your needs

\*See Cascade Microtech's Terms and Conditions of Sale for more details.

© Copyright 2015 Cascade Microtech, Inc.  
All rights reserved. Cascade Microtech is a registered trademark, and BlueRay, Velox, Velox Pro, Spectrum and MultiDie are trademarks of Cascade Microtech, Inc. All other trademarks are the property of their respective owners.

Data subject to change without notice

PA200BR-DS-0715

**Cascade Microtech, Inc.**  
**Corporate Headquarters**  
toll free: +1-800-550-3279  
phone: +1-503-601-1000  
email: [cmi\\_sales@cmicro.com](mailto:cmi_sales@cmicro.com)

**Germany**  
phone: +49-35240-73-333  
email: [cmg\\_sales@cmicro.com](mailto:cmg_sales@cmicro.com)

**Japan**  
phone: +81-3-5615-5150  
email: [cmj\\_sales@cmicro.com](mailto:cmj_sales@cmicro.com)

**China**  
phone: +86-21-3330-3188  
email: [cmc\\_sales@cmicro.com](mailto:cmc_sales@cmicro.com)

**Singapore**  
phone: +65-6873-7482  
email: [cms\\_sales@cmicro.com](mailto:cms_sales@cmicro.com)

**Taiwan**  
phone: +886-3-5722810  
email: [cmt\\_sales@cmicro.com](mailto:cmt_sales@cmicro.com)

