

MPEM

Multipurpose EM
25 mA / 10 V

DATA SHEET

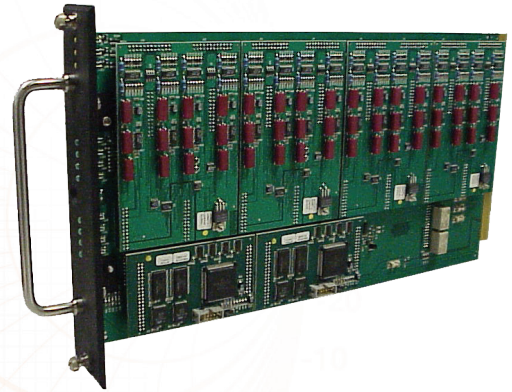

Cascade Microtech's Multipurpose Electromigration Module (MPEM) provides multiple stress bias types including constant voltage electromigration (CVEM), constant current electromigration (CIEM), low frequency pulsed current electromigration (LFPEM), and stress migration (SM). It is designed for testing copper interconnects which typically have geometries of 90 nm and smaller.

The MPEM Module's high-rate measurement system reliably captures DUT failures with excellent time precision, describes pre-breakdown behavior in detail, and can even log short duration resistance changes in order to evaluate 'self-healing' voiding behavior.

With an intuitive, full-featured test suite, EM and SM experiment data is analyzed quickly to determine DUT failure times. The data analysis tools offer full Black's Equation evaluation for accurate lifetime projections with confidence intervals. All data can easily be exported to other applications for analysis.

FEATURES / BENEFITS

Flexibility	<ul style="list-style-type: none">Provides multiple stress bias modes, including CVEM, CIEM, and LFPEMCompatible with both 1164 and Symphony™ reliability test systemsBroad measurement range, setpoints as low as 10 μA or 10 mVAccurate source/measurement systemTwo types of extrusion monitors per DUTFull-featured test suite, including EM, TCR, and SM
Full parallel measurements	<ul style="list-style-type: none">Dedicated high-accuracy multipurpose SMU for each DUTContinuous monitoring of all DUTs — no scanningInstant capture of momentary DUT behaviorQuick disconnect upon DUT failure4-wire Kelvin connections
Maximum efficiency	<ul style="list-style-type: none">Industry's best package-level test throughput with 1164Highly parallel wafer-level reliability testing with 1164 or Symphony

FULL PARALLEL MEASUREMENT

16 SMUs	<p>One per DUT</p> <p>Including multipurpose source (constant voltage, constant current, or pulsed current) source, ammeter, and voltmeter</p> <p>To independently source voltage or current for each device</p> <p>Continuously measure the current through and voltage across each DUT without scanning through a switch matrix</p> <p>Provide 4-wire Kelvin bias and measurement</p> <p>Each DUT may have different current voltage, current, or current density, set points</p>
16 voltage extrusion monitors	<p>One voltmeter per DUT</p> <p>To continuously monitor voltage on an optional extrusion monitor line</p>
16 current leakage monitors	<p>One ammeter per DUT</p> <p>To continuously monitor current leakage to an optional extrusion monitor line</p>

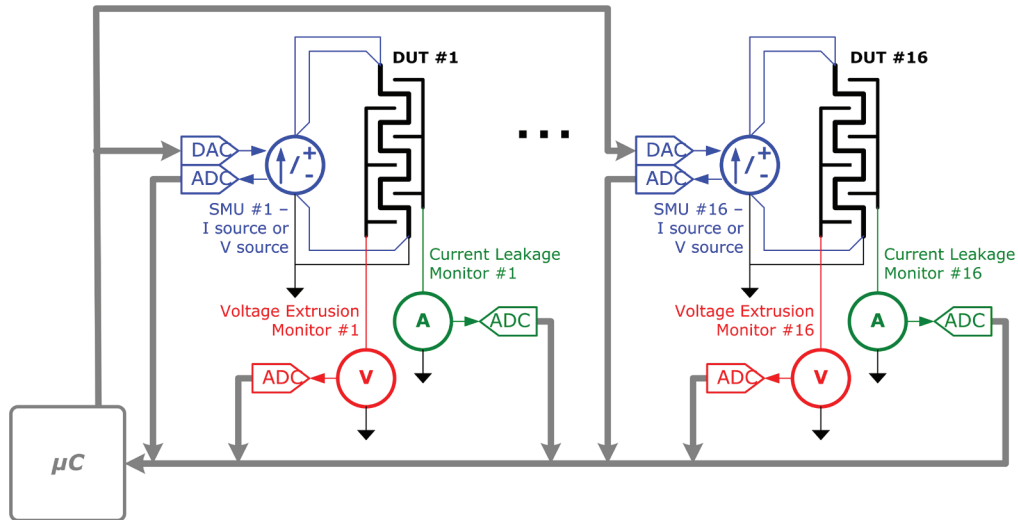

Full parallel measurement system: dedicated SMUs, voltage extrusion monitors and current leakage monitors, one each per DUT.

SPECIFICATIONS

Parameter	SMU	Current Leakage Monitor	Voltage Extrusion Monitor
Capacity	Up to 16 DUTs		
Maximum current	+25 mA per DUT	5 μ A per DUT	-
Maximum voltage	+10 V	-	+10 V
Source resolution (CI mode, LFP mode)	400 nA (250 μ A - 25 mA) 4 nA (below 250 μ A)	-	-
Source resolution (CV mode)	160 μ V	-	-
Source accuracy (CI mode, LFP mode)	0.1 % \pm 2.5 μ A (250 μ A - 25 mA) 0.1 % \pm 25 nA (below 250 μ A)	-	-
Source accuracy (CV mode)	0.1 % \pm 1 mV	-	-
Measure resolution	10 μ V (625 mV - 10 V) 600 nV (below 625 mV) 25 nA (250 μ A - 25 mA) 250 pA (below 250 μ A)	5 pA	10 μ V
Measure accuracy	0.1 % \pm 200 μ V (625 mV - 10 V) 0.1 % \pm 20 μ V (below 625 mV) 0.1 % \pm 1 μ A (250 μ A - 25 mA) 0.1 % \pm 50 nA (below 250 μ A)	0.1 % \pm 1 nA	0.1 % \pm 600 μ V
Max pulse frequency (LFP mode)	10 Hz [DUT R \leq 1 k Ω] 1 Hz [1 k Ω - 10 k Ω]	-	-
Pulse duty cycle range (LFP mode)	10% - 90% [DUT R \leq 1 k Ω] 20% - 80% [1 k Ω - 10 k Ω]	-	-
Pulse period accuracy (LFP mode)	\pm 5 ms [DUT R \leq 1 k Ω] \pm 10 ms [1 k Ω - 10 k Ω]	-	-
Sampling interval	<0.1 sec	<0.1 sec	<0.1 sec

*Data, design and specification depend on individual process conditions and can vary according to equipment configurations.
Not all specifications may be valid simultaneously.

RECOMMENDED OPERATING RANGE

Parameter	Value
Current set-point range (CI mode, LFP mode)	10 μ A ~ 25 mA
Voltage set-point range (CV mode)	10 mV ~ 10 V
Current measurement range	10 μ A ~ 25 mA
Voltage measurement range	400 μ V ~ 10 V
DUT resistance measurement range	1 Ω ~ 100 k Ω (10 k Ω max for pulsed stress)
DUT power range	Up to 2 W per package

REGULATORY COMPLIANCE

Certification	CE, SEMI S2
---------------	-------------

WARRANTY

Warranty*	Fifteen months from date of delivery or twelve months from date of installation (whichever comes first)
Service contracts	Single- and multi-year programs available to suit your needs

*See Cascade Microtech's Terms and Conditions of Sale for more details.

ORDERING INFORMATION

Consult factory for more detailed specifications, additional options, suitability of configuration for intended usage, part numbers, pricing, and delivery.

© Copyright 2015 Cascade Microtech, Inc.
All rights reserved. Cascade Microtech is a registered trademark, and Symphony is a trademark of Cascade Microtech, Inc. All other trademarks are the property of their respective owners.

Data subject to change without notice.

Cascade Microtech, Inc.
Corporate Headquarters
toll free: +1-800-550-3279
phone: +1-503-601-1000
email: cmi_sales@cmicro.com

Germany
phone: +49-35240-73-333
email: cmg_sales@cmicro.com

Japan
phone: +81-3-5615-5150
email: cmj_sales@cmicro.com

China
phone: +86-21-3330-3188
email: cmc_sales@cmicro.com

Singapore
phone: +65-6873-7482
email: cms_sales@cmicro.com

Taiwan
phone: +886-3-5722810
email: cmt_sales@cmicro.com

MPEM-DS-0715

MPEM

www.cascademicrotech.com

