

# The DEETER Group®

## 30 Series Horizontal Liquid Level Sensor

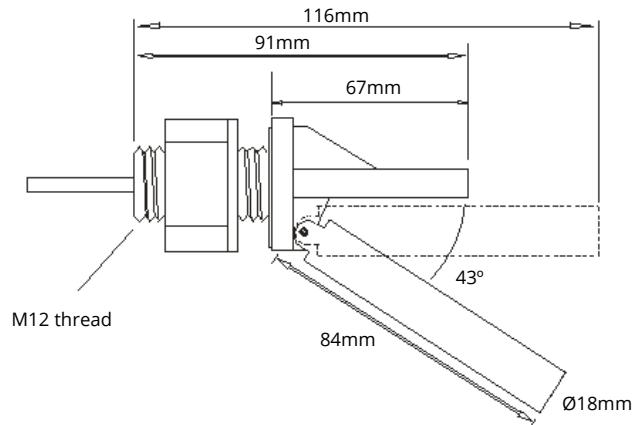

- High Power Switching.
- Self cleaning hinge mechanism.
- Suitable for harsh environments.
- Good chemical resistance.
- Wide operating temperature range.
- Change switch operation from normally open (N/O) to normally close (N/C) by rotating the switch so the float is above the centre line.
- The weight of the sensor is approximately 48g.
- A 1 meter PVC cable is provided as standard, for custom cable lengths, contact sales office.

### Fixing

	Hole Size	Torque	Wall Thickness
<b>M12</b>	12.5mm	6.8Nm	10mm

\*For larger wall thickness contact the sales office for advice

### Technical Data

	Nylon	Polypropylene
<b>Suitable specific gravity</b>	0.7	0.7
<b>Maximum Pressure</b>	4 bar	4 bar
<b>Operating Temperature</b>	-20°C to +80°C	-20°C to + 80°C

\*For Chemical resistance data contact the sales office. Higher switch ratings are available.

Deeter House  
Valley Road  
Hughenden Valley  
Bucks HP14 4LW

Tel: +44 (0)1494 566 046  
Fax: +44 (0)1494 563 961  
Email: sales@deeter.co.uk



www.deeter.co.uk

# The DEETER Group®

## 30 Series Horizontal Liquid Level Sensor

### Ordering Code

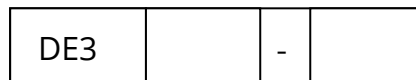

Material

3 - Nylon

4 - Polypropylene

Switch Contact Ratings

90A - 240V AC/DC, 3A, 90W

50A - 240V AC/DC, 3A, 50W

Example: DE33-90A = 30 Series, Material Nylon, Form A SPST, 90 Watt float switch.

For AC circuits ensure the peak voltage x current does not exceed the power rating.

**All electrical equipment should be installed by a qualified/certified electrician.**

The Deeter Group follows a policy of continual development of its products and reserves the right to change specifications and/or features without notice.

Deeter House  
Valley Road  
Hughenden Valley  
Bucks HP14 4LW

Tel: +44 (0)1494 566 046  
Fax: +44 (0)1494 563 961  
Email: sales@deeter.co.uk



www.deeter.co.uk