

The DEETER Group®

20 Series Vertical Liquid Level Sensor

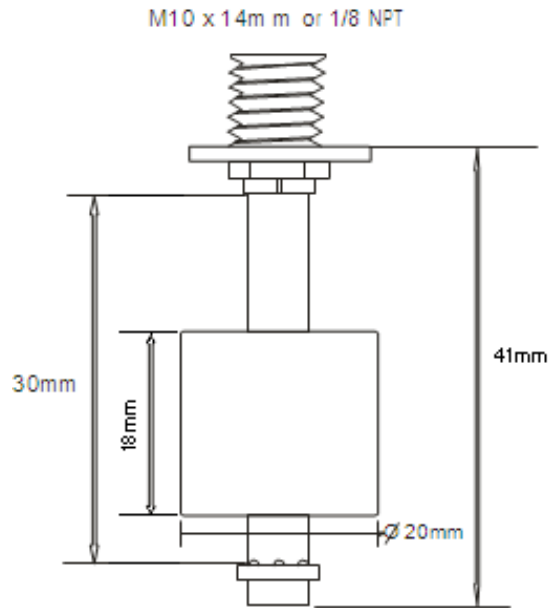

- Designed for cost sensitive high volume OEM applications.
- High reliability reed switch lifetime of 5×10^7 operations.
- Available in PVC, Polypropylene, Nylon and Acetal materials.
- Change switch operation from normally open (N/O) to normally close (N/C) by inverting float on stem.
- Ideal for beverage, automotive and consumer applications.
- A 1 meter cable is provided as standard, for custom cable lengths, contact sales office.

Technical Data

	PVC	Polypropylene	Nylon	Acetal
Suitable specific gravity	0.63	0.49	0.5	0.62
Operating Temperature	-20°C to + 60°C	-20°C to + 80°C	-20°C to +80°C	-20°C to + 90°C

Deeter House
Valley Road
Hughenden Valley
Bucks HP14 4LW

Tel: +44 (0)1494 566 046
Fax: +44 (0)1494 563 961
Email: sales@deeter.co.uk



www.deeter.co.uk

The DEETER Group®

20 Series Vertical Liquid Level Sensor

Ordering Code

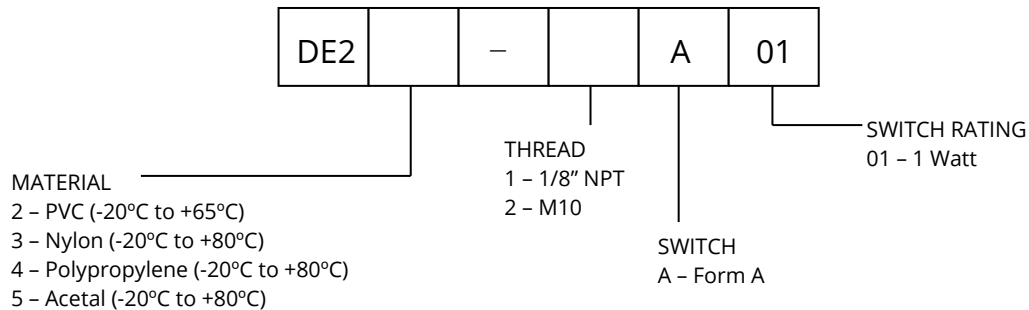

Example: DE22-2A01 = 20 Series, Material PVC, M10 mounting thread, Form A (SPST), 1 Watt float switch.
For longer cable lengths, contact the sales office.

Caution: NPT threads are specified in their reference size.
This size does not refer to the physical thread diameter.

All electrical equipment should be installed by a qualified/certified electrician.

The Deeter Group follows a policy of continual development of its products and reserves the right to change specifications and/or features without notice.

Deeter House
Valley Road
Hughenden Valley
Bucks HP14 4LW

Tel: +44 (0)1494 566 046
Fax: +44 (0)1494 563 961
Email: sales@deeter.co.uk



www.deeter.co.uk