

TC911A/TC911B

Monolithic Auto-Zeroed Operational Amplifiers

Features

- First Monolithic Chopper-Stabilized Amplifier with On-Chip Nulling Capacitors
- Low Offset Voltage: 5 μ V
- Low Offset Voltage Drift: 0.05 μ V/°C
- Low Supply Current: 350 μ A
- High Common-Mode Rejection: 116dB
- Single Supply Operation: 4.5V to 16V
- High Slew Rate: 2.5V/ μ sec
- Wide Bandwidth: 1.5MHz
- High Open-Loop Voltage Gain: 120dB
- Low Input Noise Voltage: 0.65 μ V_{p-p} (0.1Hz to 1Hz)
- Pin Compatible With ICL7650
- Lower System Parts Count

Applications

- Instrumentation
- Portable/Battery Powered
- Embedded Control
- Temperature Sensor Amplifier
- Strain Gage Amplifier

Package Type

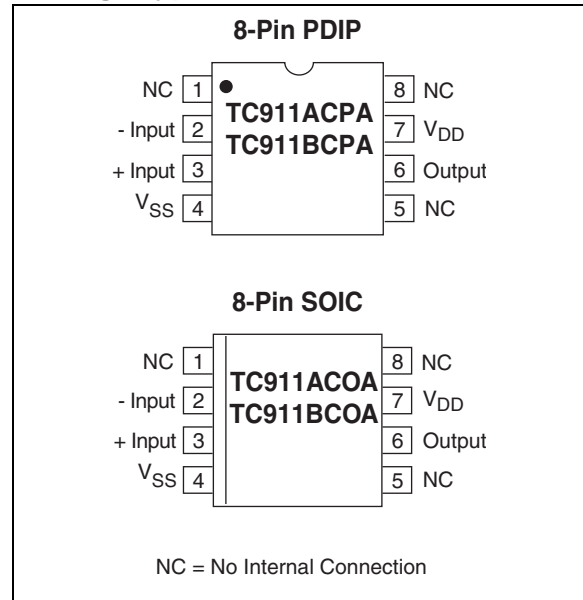

Device Selection Table

Part Number	Package	Temperature Range	Offset Voltage
TC911ACOA	8-Pin SOIC	0°C to +70°C	15 μ V
TC911ACPA	8-Pin PDIP	0°C to +70°C	15 μ V
TC911BCOA	8-Pin SOIC	0°C to +70°C	30 μ V
TC911BCPA	8-Pin PDIP	0°C to +70°C	30 μ V

TC911A/TC911B

General Description

The TC911 CMOS auto-zeroed operational amplifier is the first complete monolithic chopper stabilized amplifier. Chopper operational amplifiers like the ICL7650/7652 and LTC1052 require user supplied, external offset compensation storage capacitors. **External capacitors are not required with the TC911.** Just as easy to use as the conventional OP07 type amplifier, the TC911 significantly reduces offset voltage errors. Pinout matches the OP07/741/7650 8-pin mini-DIP configuration.

Several system benefits arise by eliminating the external chopper capacitors: lower system parts count, reduced assembly time and cost, greater system reli-

ability, reduced PC board layout effort and greater board area utilization. Space savings can be significant in multiple amplifier designs.

Electrical specifications include 15 μ V maximum offset voltage and 0.15 μ V/ $^{\circ}$ C maximum offset voltage temperature co-efficient. Offset voltage error is five times lower than the premium OP07E bipolar device. The TC911 improves offset drift performance by eight times.

The TC911 operates from dual or single power supplies. Supply current is typically 350 μ A. Single 4.5V to 16V supply operation is possible, making single 9V battery operation possible. The TC911 is available in 2 package types: 8-pin plastic DIP and SOIC.

Functional Block Diagram

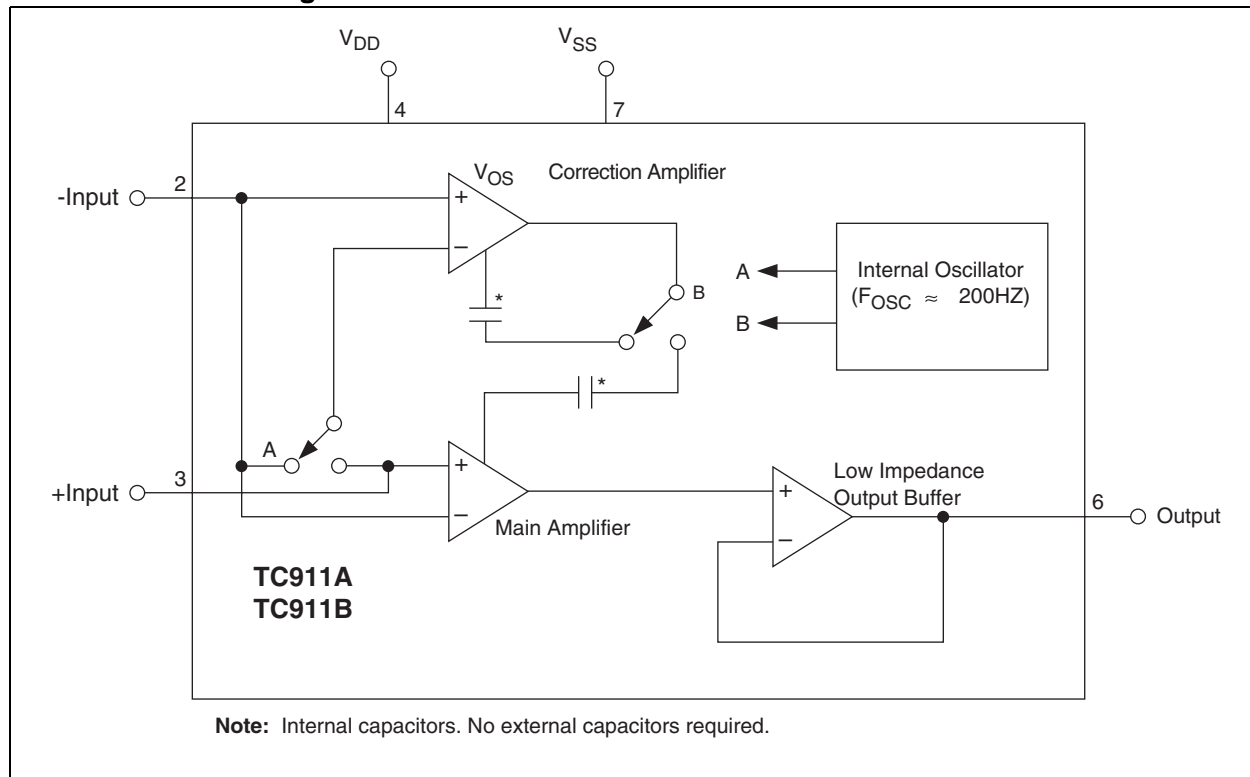

1.0 ELECTRICAL CHARACTERISTICS

Absolute Maximum Ratings*

Total Supply Voltage (V_{DD} to V_{SS})	-18V
Input Voltage	$V_{DD} + 0.3V$ to $(V_{SS} - 0.3V)$
Current Into Any Pin.....	10mA
While Operating	100 μ A
Package Power Dissipation ($T_A - 70^\circ\text{C}$)	
Plastic DIP.....	730mW
Plastic SOIC.....	470mW
Operating Temperature Range	
C Device.....	0 $^\circ\text{C}$ to +70 $^\circ\text{C}$
Storage Temperature Range.....	-65 $^\circ\text{C}$ to +150 $^\circ\text{C}$

*Stresses above those listed under "Absolute Maximum Ratings" may cause permanent damage to the device. These are stress ratings only and functional operation of the device at these or any other conditions above those indicated in the operation sections of the specifications is not implied. Exposure to Absolute Maximum Rating conditions for extended periods may affect device reliability.

TC911A AND TC911B ELECTRICAL SPECIFICATIONS

Electrical Characteristics: $V_S = \pm 5V$, $T_A = +25^\circ\text{C}$, unless otherwise indicated.										
Symbol	Parameter	Min	TC911A			TC911B			Unit	Test Conditions
			Typ	Max	Min	Typ	Max			
V_{OS}	Input Offset Voltage	—	5	15	—	15	30	μV	$T_A = +25^\circ\text{C}$	
TCV_{OS}	Average Temp. Coefficient of Input Offset Voltage	—	0.05	0.15	—	0.1	0.25	$\mu\text{V}/^\circ\text{C}$	$0^\circ\text{C} \leq T_A \leq +70^\circ\text{C}$ $-25^\circ\text{C} \leq T_A \leq +85^\circ\text{C}$ (Note 1)	
I_B	Average Input Bias Current	—	—	70	—	—	120	pA	$T_A = +25^\circ\text{C}$	
		—	—	3	—	—	4	nA	$0^\circ\text{C} \leq T_A \leq +70^\circ\text{C}$	
		—	—	4	—	—	6	nA	$-25^\circ\text{C} \leq T_A \leq +85^\circ\text{C}$	
I_{OS}	Average Input Offset Current	—	5	20	—	10	40	pA	$T_A = +25^\circ\text{C}$	
		—	—	1	—	—	1	nA	$T_A = +85^\circ\text{C}$	
e_N	Input Voltage Noise	—	0.65	—	—	0.65	—	μV_{P-P}	0.1 to 1Hz, $R_S \leq 100\Omega$	
		—	11	—	—	11	—	μV_{P-P}	0.1 to 10Hz, $R_S \leq 100\Omega$	
CMRR	Common Mode Rejection Ratio	110	116	—	105	110	—	dB	$V_{SS} \leq V_{CM} \leq V_{DD} - 2.2$	
CMVR	Common Mode Voltage Range	V_{SS}	—	$V_{DD} - 2$	V_{SS}	—	$V_{DD} - 2$	V		
A_{OL}	Open-Loop Voltage Gain	115	120	—	110	120	—	dB	$R_L = 10\text{k}\Omega$, $V_{OUT} = \pm 4V$	
V_{OUT}	Output Voltage Swing	$V_{SS} + 0.3$	—	$V_{DD} - 0.9$	$V_{SS} + 0.3$	—	$V_{DD} - 0.9$	V	$R_L = 10\text{k}\Omega$	
BW	Closed Loop Bandwidth	—	1.5	—	—	1.5	—	MHz	Closed Loop Gain = +1	
SR	Slew Rate	—	2.5	—	—	2.5	—	V/ μsec	$R_L = 10\text{k}\Omega$, $C_L = 50\text{pF}$	
PSRR	Power Supply Rejection Ratio	112	—	—	105	—	—	dB	$\pm 3.3V$ to $\pm 5.5V$	
V_S	Operating Supply Voltage Range	± 3.3	—	± 8	± 3.3	—	± 8	V	Split Supply	
		6.5	—	16	6.5	—	16	V	Single Supply	
I_S	Quiescent Supply Current	—	350	600	—	—	800	μA	$V_S = \pm 5V$	

Note 1: Characterized; not 100% tested.

TC911A/TC911B

2.0 PIN DESCRIPTIONS

The descriptions of the pins are listed in <Blue References>Table 2-1.

TABLE 2-1: PIN FUNCTION TABLE

Pin Number	Symbol	Description
1, 5, 8	NC	No Internal Connection.
2	-INPUT	Inverting Input
3	+INPUT	Non-inverting Input
4	V _{SS}	Negative Power Supply
6	OUTPUT	Output
7	V _{DD}	Positive Power Supply

3.0 DETAILED DESCRIPTION

3.1 Pin Compatibility

The CMOS TC911 is pin compatible with the industry standard ICL7650 chopper stabilized amplifier. The ICL7650 must use external 0.1μF capacitors connected at pins 1 and 8. **With the TC911, external offset voltage error canceling capacitors are not required.** On the TC911 pins 1, 8 and 5 are not connected internally. The ICL7650 uses pin 5 as an optional output clamp connection. External chopper capacitors and clamp connections are not necessary with the TC911. External circuits connected to pins 1, 8 and 5 will have no effect. The TC911 can be quickly evaluated in existing ICL7650 designs. Since external capacitors are not required, system part count, assembly time and total system cost are reduced. Reliability is increased and PC board layout eased by having the error storage capacitors integrated on the TC911 chip.

The TC911 pinout matches many existing op amps: 741, LM101, LM108, OP05–OP08, OP-20, OP-21, ICL7650 and ICL7652. In many applications operating from +5V supplies, the TC911 offers superior electrical

performance and can be a functional pin compatible replacement. Offset voltage correction potentiometers, compensation capacitors, and chopper stabilization capacitors can be removed when retro-fitting existing equipment designs.

3.2 Thermocouple Errors

Heating one joint of a loop made from two different metallic wires causes current flow. This is known as the Seebeck effect. By breaking the loop, an open circuit voltage (Seebeck voltage) can be measured. Junction temperature and metal type determine the magnitude. Typical values are 0.1μV/°C to 10μV/°C. Thermal induced voltages can be many times larger than the TC911 offset voltage drift. Unless unwanted thermocouple potentials can be controlled, system performance will be less than optimum.

Unwanted thermocouple junctions are created when leads are soldered or sockets/connectors are used. Low thermo-electric coefficient solder can reduce errors. A 60% Sn/36% Pb solder has 1/10 the thermal voltage of common 64% Sn/36% Pb solder at a copper junction.

The number and type of dissimilar metallic junctions in the input circuit loop should be balanced. If the junctions are kept at the same temperature, their summation will add to zero-canceling errors (Figure 3-1).

Shielding precision analog circuits from air currents - especially those caused by power dissipating components and fans - will minimize temperature gradients and thermocouple induced errors.

FIGURE 3-1: UNWANTED THERMOCOUPLE ERRORS ELIMINATED BY REDUCING THERMAL GRADIENTS AND BALANCING JUNCTIONS

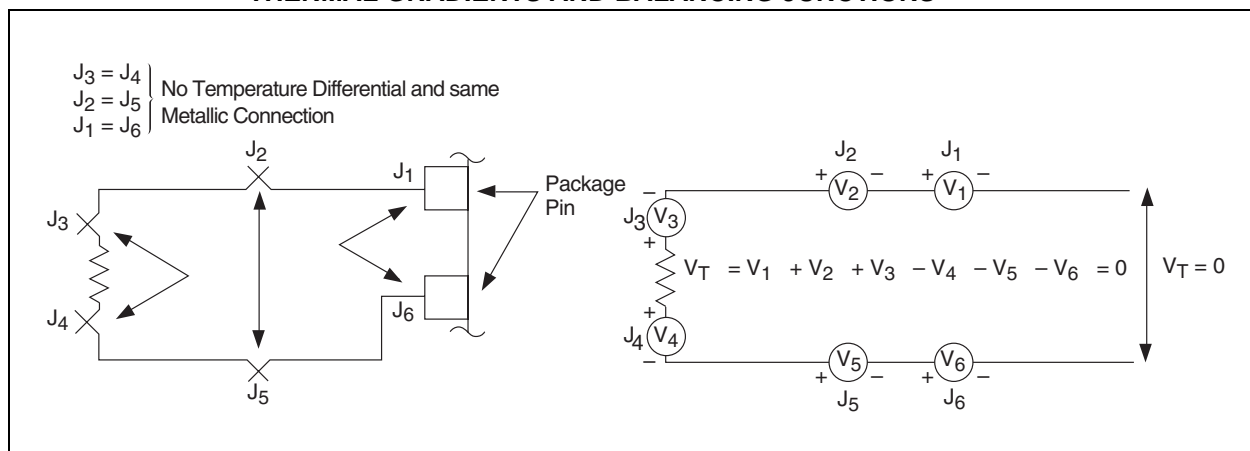

3.3 Avoiding Latchup

Junction isolated CMOS circuits inherently contain a parasitic p-n-p-n transistor circuit. Voltages exceeding the supplies by 0.3V should not be applied to the device pins. Larger voltages can turn the p-n-p-n device on, causing excessive device power supply current and excessive power dissipation. TC911 power supplies should be established at the same time or before input signals are applied. If this is not possible, input current should be limited to 0.1mA to avoid triggering the p-n-p-n structure.

3.4 Overload Recovery

The TC911 recovers quickly from the output saturation. Typical recovery time from positive output saturation is 20msec. Negative output saturation recovery time is typically 5msec.

TC911A/TC911B

4.0 TYPICAL APPLICATIONS

FIGURE 4-1: THERMOMETER CIRCUIT

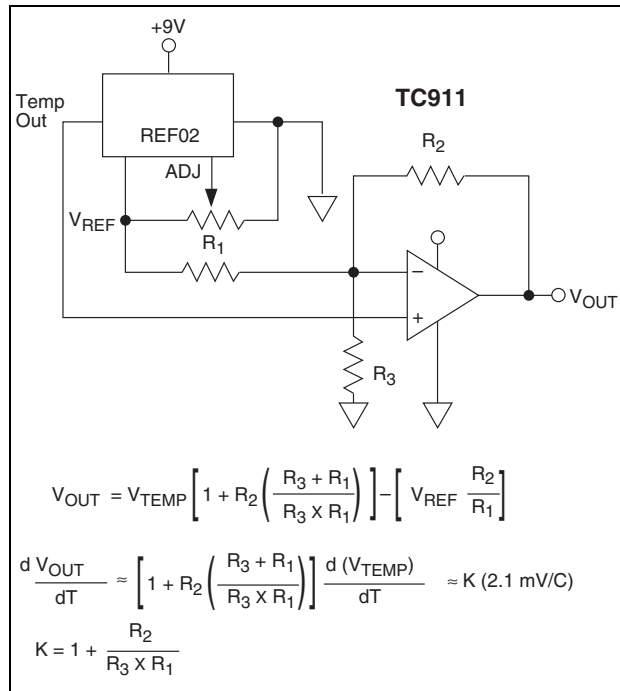

FIGURE 4-2: 10-VOLT PRECISION REFERENCE

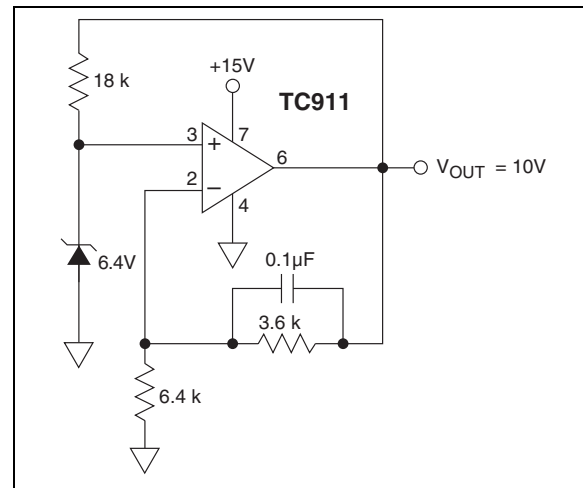
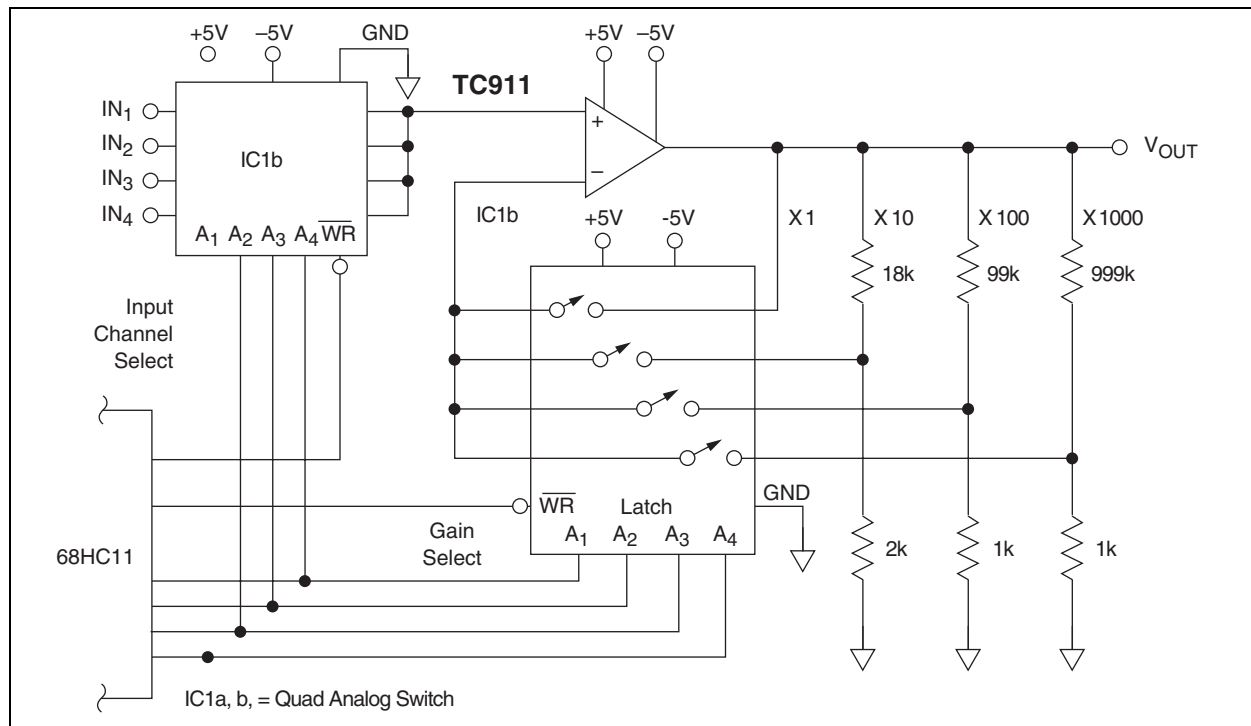
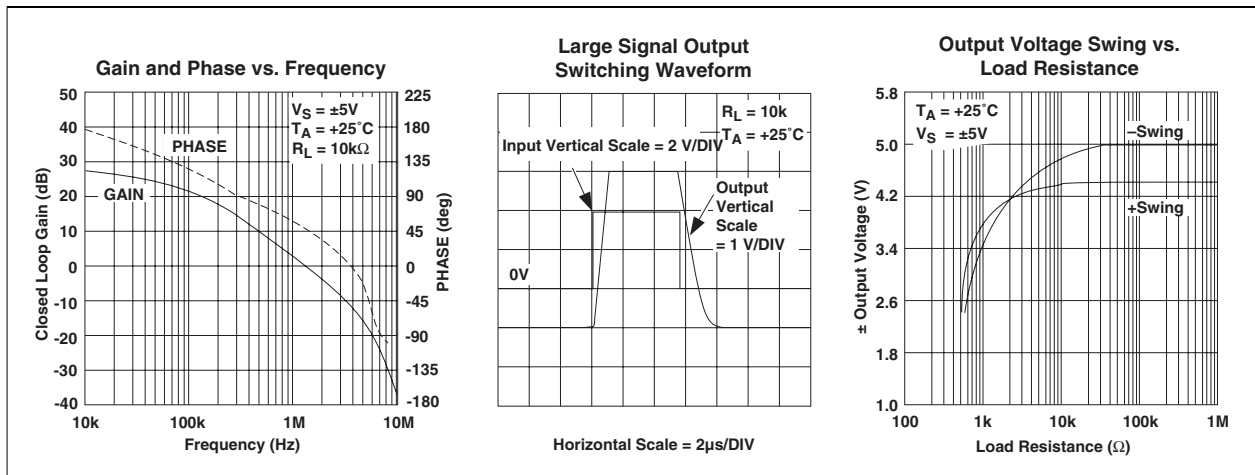
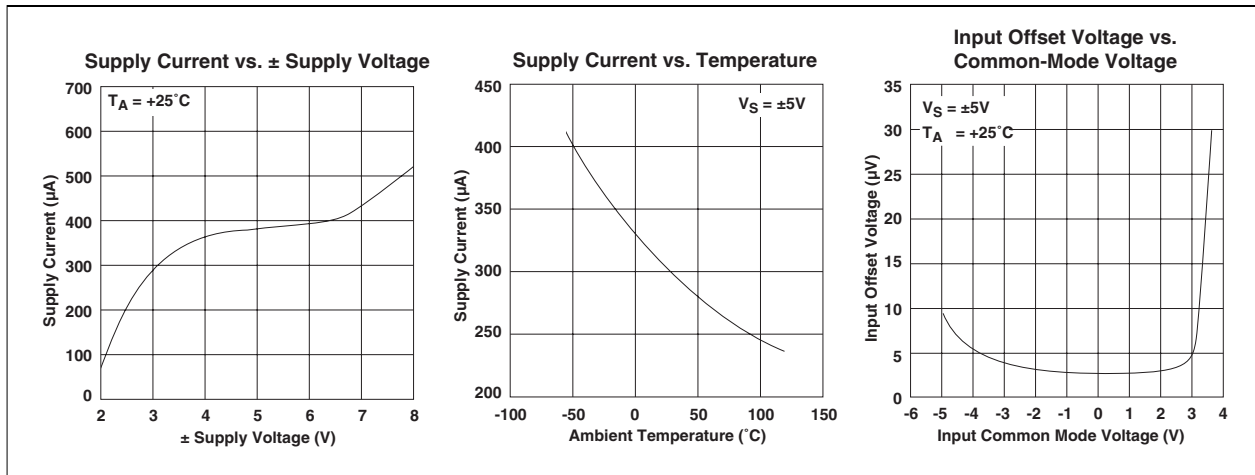

FIGURE 4-3: PROGRAMMABLE GAIN AMPLIFIER WITH INPUT MULTIPLEXER



5.0 TYPICAL CHARACTERISTICS

Note: The graphs and tables provided following this note are a statistical summary based on a limited number of samples and are provided for informational purposes only. The performance characteristics listed herein are not tested or guaranteed. In some graphs or tables, the data presented may be outside the specified operating range (e.g., outside specified power supply range) and therefore outside the warranted range.



TC911A/TC911B

6.0 PACKAGING INFORMATION

6.1 Package Marking Information

Package marking data not available at this time.

6.2 Taping Form

Component Taping Orientation for 8-Pin SOIC (Narrow) Devices

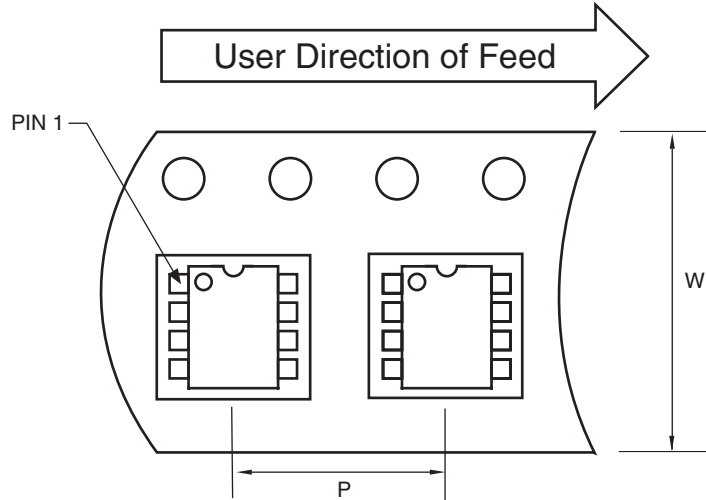

Standard Reel Component Orientation
for TR Suffix Device

Carrier Tape, Number of Components Per Reel and Reel Size

Package	Carrier Width (W)	Pitch (P)	Part Per Full Reel	Reel Size
8-Pin SOIC (N)	12 mm	8 mm	2500	13 in

6.3 Package Dimensions

8-Pin SOIC

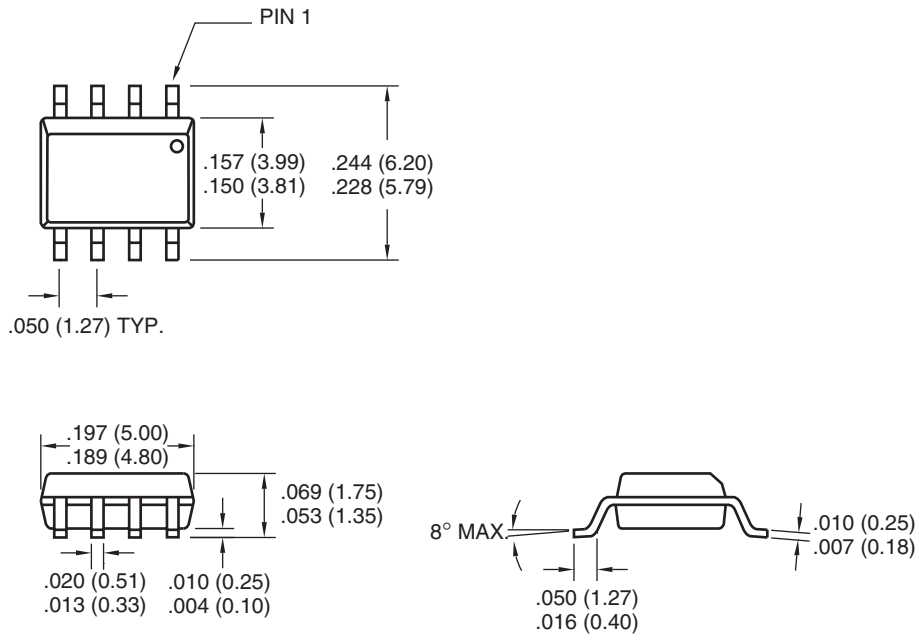

Dimensions: inches (mm)

8-Pin Plastic DIP

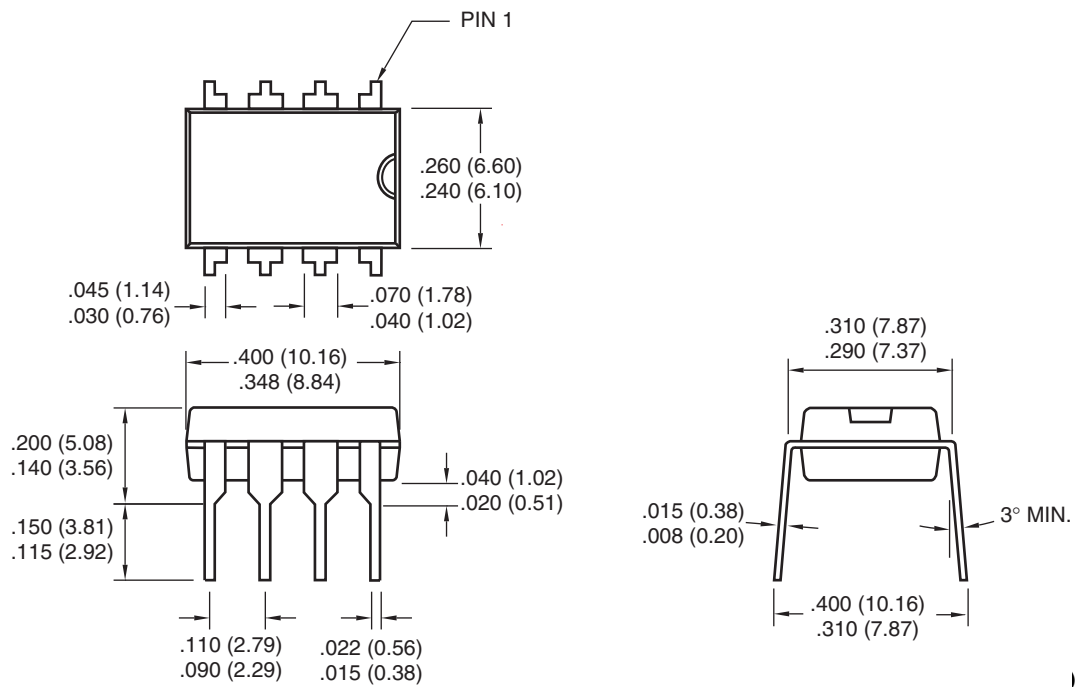

Dimensions: inches (mm)

TC911A/TC911B

NOTES:

SALES AND SUPPORT

Data Sheets

Products supported by a preliminary Data Sheet may have an errata sheet describing minor operational differences and recommended workarounds. To determine if an errata sheet exists for a particular device, please contact one of the following:

1. Your local Microchip sales office
2. The Microchip Corporate Literature Center U.S. FAX: (480) 792-7277
3. The Microchip Worldwide Site (www.microchip.com)

Please specify which device, revision of silicon and Data Sheet (include Literature #) you are using.

New Customer Notification System

Register on our web site (www.microchip.com/cn) to receive the most current information on our products.

TC911A/911B

NOTES:

Note the following details of the code protection feature on Microchip devices:

- Microchip products meet the specification contained in their particular Microchip Data Sheet.
- Microchip believes that its family of products is one of the most secure families of its kind on the market today, when used in the intended manner and under normal conditions.
- There are dishonest and possibly illegal methods used to breach the code protection feature. All of these methods, to our knowledge, require using the Microchip products in a manner outside the operating specifications contained in Microchip's Data Sheets. Most likely, the person doing so is engaged in theft of intellectual property.
- Microchip is willing to work with the customer who is concerned about the integrity of their code.
- Neither Microchip nor any other semiconductor manufacturer can guarantee the security of their code. Code protection does not mean that we are guaranteeing the product as "unbreakable."

Code protection is constantly evolving. We at Microchip are committed to continuously improving the code protection features of our products. Attempts to break Microchip's code protection feature may be a violation of the Digital Millennium Copyright Act. If such acts allow unauthorized access to your software or other copyrighted work, you may have a right to sue for relief under that Act.

Information contained in this publication regarding device applications and the like is provided only for your convenience and may be superseded by updates. It is your responsibility to ensure that your application meets with your specifications. MICROCHIP MAKES NO REPRESENTATIONS OR WARRANTIES OF ANY KIND WHETHER EXPRESS OR IMPLIED, WRITTEN OR ORAL, STATUTORY OR OTHERWISE, RELATED TO THE INFORMATION, INCLUDING BUT NOT LIMITED TO ITS CONDITION, QUALITY, PERFORMANCE, MERCHANTABILITY OR FITNESS FOR PURPOSE. Microchip disclaims all liability arising from this information and its use. Use of Microchip's products as critical components in life support systems is not authorized except with express written approval by Microchip. No licenses are conveyed, implicitly or otherwise, under any Microchip intellectual property rights.

Trademarks

The Microchip name and logo, the Microchip logo, Accuron, dsPIC, KEELOQ, microID, MPLAB, PIC, PICmicro, PICSTART, PRO MATE, PowerSmart, rPIC, and SmartShunt are registered trademarks of Microchip Technology Incorporated in the U.S.A. and other countries.

AmpLab, FilterLab, Migratable Memory, MXDEV, MXLAB, PICMASTER, SEEVAL, SmartSensor and The Embedded Control Solutions Company are registered trademarks of Microchip Technology Incorporated in the U.S.A.

Analog-for-the-Digital Age, Application Maestro, dsPICDEM, dsPICDEM.net, dsPICworks, ECAN, ECONOMONITOR, FanSense, FlexROM, fuzzyLAB, In-Circuit Serial Programming, ICSP, ICEPIC, Linear Active Thermistor, MPASM, MPLIB, MPLINK, MPSIM, PCKIT, PICDEM, PICDEM.net, PICLAB, PICtail, PowerCal, PowerInfo, PowerMate, PowerTool, rLAB, rPICDEM, Select Mode, Smart Serial, SmartTel, Total Endurance and WiperLock are trademarks of Microchip Technology Incorporated in the U.S.A. and other countries.

SQTP is a service mark of Microchip Technology Incorporated in the U.S.A.

All other trademarks mentioned herein are property of their respective companies.

© 2005, Microchip Technology Incorporated, Printed in the U.S.A., All Rights Reserved.

 Printed on recycled paper.

**QUALITY MANAGEMENT SYSTEM
CERTIFIED BY DNV
== ISO/TS 16949:2002 ==**

Microchip received ISO/TS-16949:2002 quality system certification for its worldwide headquarters, design and wafer fabrication facilities in Chandler and Tempe, Arizona and Mountain View, California in October 2003. The Company's quality system processes and procedures are for its PICmicro® 8-bit MCUs, KEELOQ® code hopping devices, Serial EEPROMs, microperipherals, nonvolatile memory and analog products. In addition, Microchip's quality system for the design and manufacture of development systems is ISO 9001:2000 certified.



WORLDWIDE SALES AND SERVICE

AMERICAS

Corporate Office
2355 West Chandler Blvd.
Chandler, AZ 85224-6199
Tel: 480-792-7200
Fax: 480-792-7277
Technical Support:
<http://support.microchip.com>
Web Address:
www.microchip.com

Atlanta
Alpharetta, GA
Tel: 770-640-0034
Fax: 770-640-0307

Boston
Westborough, MA
Tel: 774-760-0087
Fax: 774-760-0088

Chicago
Itasca, IL
Tel: 630-285-0071
Fax: 630-285-0075

Dallas
Addison, TX
Tel: 972-818-7423
Fax: 972-818-2924

Detroit
Farmington Hills, MI
Tel: 248-538-2250
Fax: 248-538-2260

Kokomo
Kokomo, IN
Tel: 765-864-8360
Fax: 765-864-8387

Los Angeles
Mission Viejo, CA
Tel: 949-462-9523
Fax: 949-462-9608

San Jose
Mountain View, CA
Tel: 650-215-1444
Fax: 650-961-0286

Toronto
Mississauga, Ontario,
Canada
Tel: 905-673-0699
Fax: 905-673-6509

ASIA/PACIFIC

Australia - Sydney
Tel: 61-2-9868-6733
Fax: 61-2-9868-6755

China - Beijing
Tel: 86-10-8528-2100
Fax: 86-10-8528-2104

China - Chengdu
Tel: 86-28-8676-6200
Fax: 86-28-8676-6599

China - Fuzhou
Tel: 86-591-8750-3506
Fax: 86-591-8750-3521

China - Hong Kong SAR
Tel: 852-2401-1200
Fax: 852-2401-3431

China - Qingdao
Tel: 86-532-8502-7355
Fax: 86-532-8502-7205

China - Shanghai
Tel: 86-21-5407-5533
Fax: 86-21-5407-5066

China - Shenyang
Tel: 86-24-2334-2829
Fax: 86-24-2334-2393

China - Shenzhen
Tel: 86-755-8203-2660
Fax: 86-755-8203-1760

China - Shunde
Tel: 86-757-2839-5507
Fax: 86-757-2839-5571

China - Wuhan
Tel: 86-27-5980-5300
Fax: 86-27-5980-5118

China - Xian
Tel: 86-29-8833-7250
Fax: 86-29-8833-7256

ASIA/PACIFIC

India - Bangalore
Tel: 91-80-2229-0061
Fax: 91-80-2229-0062

India - New Delhi
Tel: 91-11-5160-8631
Fax: 91-11-5160-8632

India - Pune
Tel: 91-20-2566-1512
Fax: 91-20-2566-1513

Japan - Yokohama
Tel: 81-45-471-6166
Fax: 81-45-471-6122

Korea - Gumi
Tel: 82-54-473-4301
Fax: 82-54-473-4302

Korea - Seoul
Tel: 82-2-554-7200
Fax: 82-2-558-5932 or
82-2-558-5934

Malaysia - Penang
Tel: 60-4-646-8870
Fax: 60-4-646-5086

Philippines - Manila
Tel: 63-2-634-9065
Fax: 63-2-634-9069

Singapore
Tel: 65-6334-8870
Fax: 65-6334-8850

Taiwan - Hsin Chu
Tel: 886-3-572-9526
Fax: 886-3-572-6459

Taiwan - Kaohsiung
Tel: 886-7-536-4818
Fax: 886-7-536-4803

Taiwan - Taipei
Tel: 886-2-2500-6610
Fax: 886-2-2508-0102

Thailand - Bangkok
Tel: 66-2-694-1351
Fax: 66-2-694-1350

EUROPE

Austria - Wels
Tel: 43-7242-2244-399
Fax: 43-7242-2244-393

Denmark - Copenhagen
Tel: 45-4450-2828
Fax: 45-4485-2829

France - Paris
Tel: 33-1-69-53-63-20
Fax: 33-1-69-30-90-79

Germany - Munich
Tel: 49-89-627-144-0
Fax: 49-89-627-144-44

Italy - Milan
Tel: 39-0331-742611
Fax: 39-0331-466781

Netherlands - Drunen
Tel: 31-416-690399
Fax: 31-416-690340

Spain - Madrid
Tel: 34-91-708-08-90
Fax: 34-91-708-08-91

UK - Wokingham
Tel: 44-118-921-5869
Fax: 44-118-921-5820