

Auto-Ranging Analog-to-Digital Converter with 3-1/2 Digit Display

Features

- Auto-Ranging Analog-to-Digital Converter with 3-1/2 Digit Display
- Annunciator Outputs Permit Customizing of LCD
- Auto-Range Operation for AC and DC Voltage and Resistance Measurements
- Two User Selected AC/DC
- Current Ranges: 20mA and 200mA
- 22 Operating Ranges: 9 DC/AC Voltage
- 4 AC/DC Current
- 9 Resistance and Low Power Ohms
- Display Hold Function
- 3-1/2 Digit Resolution in Auto-Range Mode: 1/2000
- Extended Resolution in Manual Range Mode: 1/3000
- Internal AC-to-DC Conversion Op Amp
- Triplex LCD Drive for Decimal Points, Digits, Bar Graphs, and Annunciators
- Continuity Detection and Piezoelectric Transducer Driver
- Low Drift Internal Reference: 75ppm/°C
- 9V Battery Operation: 10mW
- Low Battery Detection and LCD Annunciator

Device Selection Table

| Part Number | Package | Operating Temperature Range |
|-------------|-------------|-----------------------------|
| TC818ACBU | 64-Pin PQFP | 0°C to +70°C |

General Description

The TC818A is an integrating analog-to-digital converter (ADC) with a 3-1/2 digit numeric LCD driver, automatic ranging, and single 9V battery operation. The numeric display provides 0.05% resolution and a full set of annunciators that spell out the TC818A's many operating modes.

Automatic range selection is provided for both voltage (DC and AC) and ohms (high and low power) measurements. Expensive and bulky mechanical range switches are not required. Five full scale ranges are available, with automatic selection of external volt/ohm attenuators over a 1 to 10,000 range. Two current ranges, 20mA and 200mA, can be manually selected. The auto-range feature can be bypassed, allowing input attenuator selection through a single line input.

During Manual mode operation, resolution is extended to 3000 counts full scale. Extended resolution is also available during 2000kΩ and 2000V full scale auto-range operation. The extended range operation is indicated by a flashing 1 MSD and by the fully extended bar graph.

The TC818A includes an AC-to-DC converter for AC voltage and current measurements. Only external diodes/resistors/capacitors are required. Other features include a Memory mode, low battery detection, display HOLD input, and continuity buzzer driver.

The 3-1/2 digit numeric display includes a full set of annunciators. Decimal points are adjusted as automatic or manual range changes occur, and Voltage, Current, and Ohms Operating modes are displayed. Additional annunciators are activated for manual, auto, memory, HOLD, AC, low power ohms, and low battery conditions.

The TC818A is available in a surface mounted 64-pin flat package. Combining a numeric display driver, single 9V battery operation, internal range switching, and compact surface mounting, the TC818A is ideal for advanced portable instruments.

TC818A

Package Type

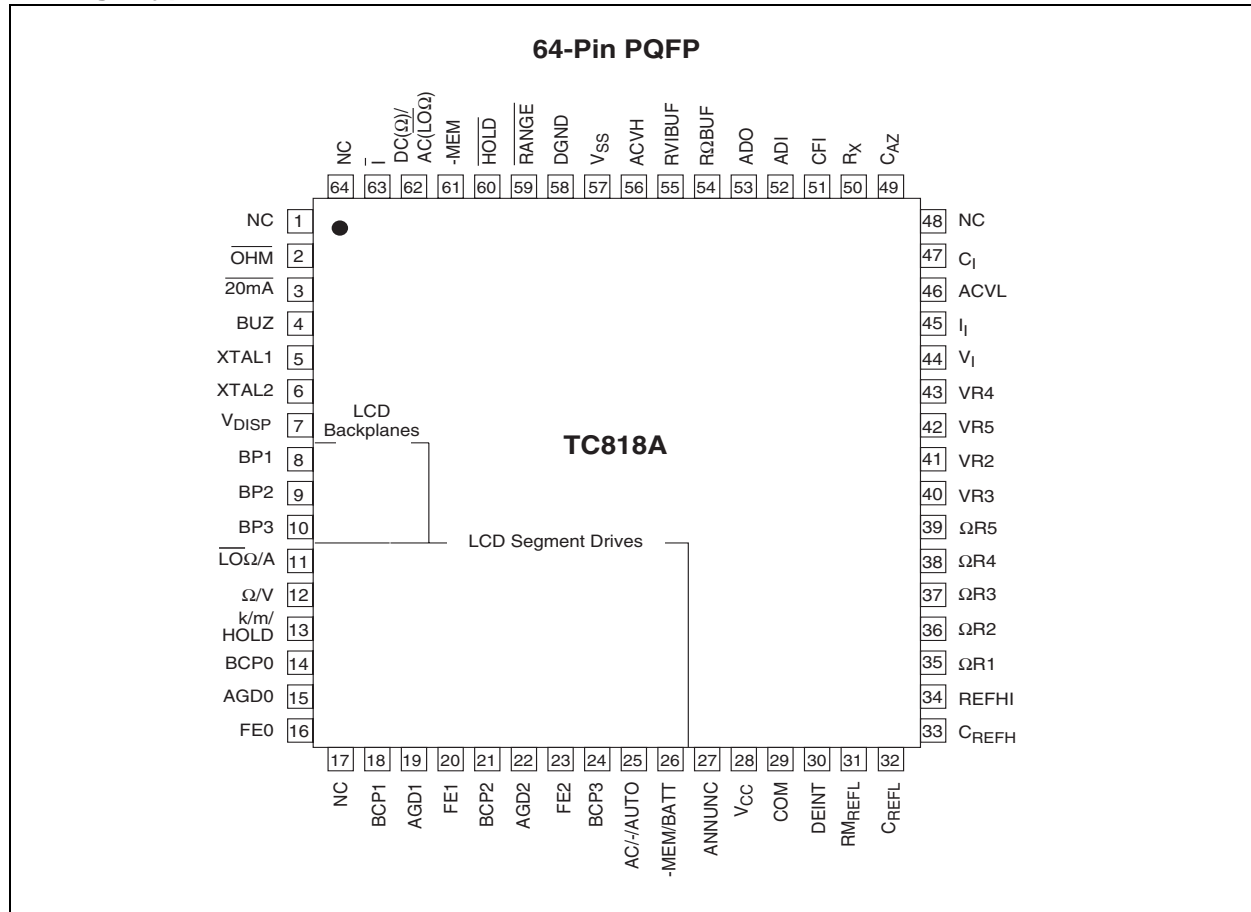

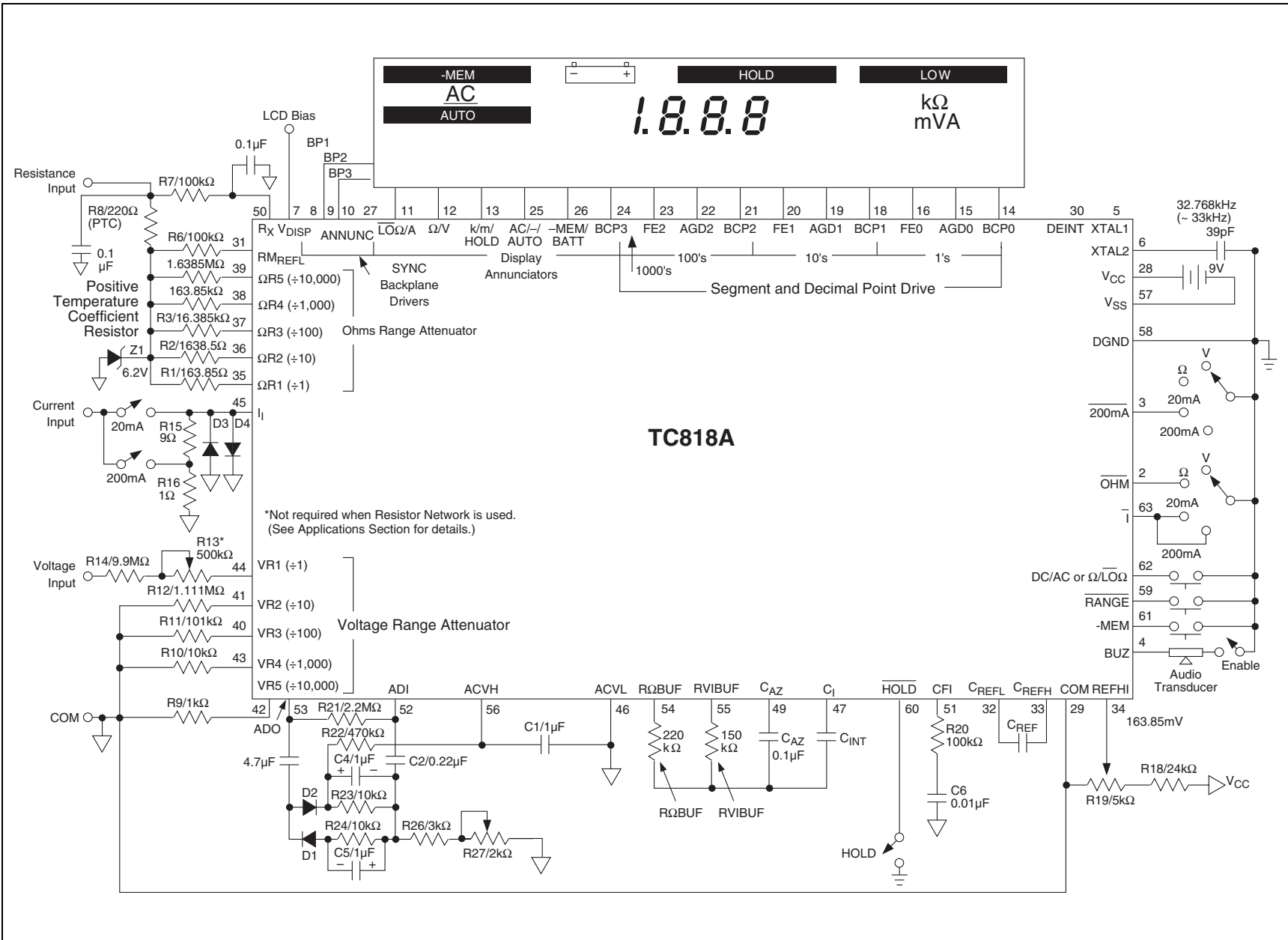

TC818A

1.0 ELECTRICAL CHARACTERISTICS

Absolute Maximum Ratings*

| | |
|----------------------------------|----------------------|
| Supply Voltage | 15V |
| Analog Input Voltage | V_{CC} to V_{SS} |
| Reference Input Voltage..... | V_{CC} to V_{SS} |
| Voltage at Pin 43 | Common $\pm 0.7V$ |
| Power Dissipation | 800mW |
| Operating Temperature Range..... | 0°C to +70°C |
| Storage Temperature Range | -65°C to +150°C |

*Stresses above those listed under "Absolute Maximum Ratings" may cause permanent damage to the device. These are stress ratings only and functional operation of the device at these or any other conditions above those indicated in the operation sections of the specifications is not implied. Exposure to Absolute Maximum Rating conditions for extended periods may affect device reliability.

TC818A ELECTRICAL SPECIFICATIONS

| Electrical Characteristics: $V_A = 9V$, $T_A = +25^\circ C$, unless otherwise specified. | | | | | | |
|--|---|-------|----------------|---------|-----------------|---|
| Symbol | Parameter | Min | Typ | Max | Unit | Test Conditions |
| | Zero Input Reading | -0000 | 0000 | +0000 | Digital Reading | 200mV Range without 10M Ω Resistor |
| | | -0001 | — | +0001 | Digital Reading | 200mV Range with 10M Ω Resistor |
| | | -0000 | 0000 | +0000 | Digital Reading | 20mA and 200mA Range |
| RE | Rollover Error | — | — | ± 1 | Counts | 200mV Range without 10M Ω Resistor |
| | | — | — | ± 3 | | 200mV Range with 10M Ω Resistor |
| | | — | — | ± 1 | | 20mA and 200mA Range |
| NL | Linearity Error | — | — | ± 1 | Count | Best Case Straight Line |
| I_{IN} | Input Leakage Current | — | — | 10 | pA | |
| E_N | Input Noise | — | 20 | — | μV_{P-P} | BW = 0.1 to 10Hz |
| | AC Frequency Error | — | ± 1 | — | % | 40 to 500Hz |
| | | — | ± 5 | — | % | Error 40 to 2000Hz |
| | Open Circuit Voltage for Ohm Measurements | — | 570 | 660 | mV | Excludes 200 Ω Range |
| | Open Circuit Voltage for \overline{LO} Ohm Measurements | — | 285 | 350 | mV | Excludes 200 Ω Range |
| V_{COM} | Analog Common Voltage | 2.8 | 3 | 3.3 | V | $(V_{CC} - V_{COM})$ |
| V_{CTC} | Common Voltage Temperature Coefficient | — | — | 50 | ppm/ $^\circ C$ | |
| | Display Multiplex Rate | — | 100 | — | Hz | |
| V_{IL} | Low Logic Input | — | — | 1 | μA | $\overline{20mA}, \overline{AC}, \overline{I}, \overline{LOW}, \overline{\Omega}, \overline{HOLD}$ Range, -MEM, OHMs (Relative to DGND, Pin 58) |
| | Logic 1 Pull-up Current | — | 25 | — | V | $\overline{20mA}, \overline{AC}, \overline{I}, \overline{LOW}, \overline{\Omega}, \overline{HOLD}$ Range, -MEM, OHMs (Relative to DGND, Pin 58) |
| V_{OL} | Low Logic Output | — | DGND +0.1 | — | V | ANNUNC, DEINT: $I_L = 100\mu A$ |
| V_{OH} | High Logic Output | — | $V_{CC} - 0.1$ | — | V | ANNUNC, DEINT: $I_L = 100\mu A$ |
| | Buzzer Drive Frequency | — | 4 | — | kHz | |
| | Low Battery Flag Voltage | 6.3 | 6.6 | 7 | V | V_{CC} to V_{SSA} |
| | Operating Supply Current | — | 0.8 | 1.5 | mA | |

2.0 PIN DESCRIPTIONS

The descriptions of the pins are listed in Table 2-1.

TABLE 2-1: PIN FUNCTION TABLE

| Pin Number (64-Pin PQFP) | Symbol | Description |
|-----------------------------|---------------------------------------|---|
| 1 | NC | No connection. |
| 2 | $\overline{\text{OHM}}$ | Logic Input. "0" (Digital Ground) for resistance measurement. |
| 3 | $\overline{20\text{mA}}$ | Logic Input. "0" (Digital Ground) for 20mA full scale current measurement. |
| 4 | BUZ | Buzzer. Audio frequency, 4kHz, output for continuity indication during resistance measurement. A noncontinuous 4kHz signal is output to indicate an input over range during voltage or current measurements. |
| 5 | XTAL1 | 32.768kHz Crystal Connection. |
| 6 | XTAL2 | 32.768kHz Crystal Connection. |
| 7 | V_{DISP} | Sets peak LCD drive signal: $V_P - V_{\text{DD}} - V_{\text{DISP}}$. V_{DISP} may also be used to compensate for temperature variation of LCD crystal threshold voltage. |
| 8 | BP1 | LCD Backplane #1. |
| 9 | BP2 | LCD Backplane #2. |
| 10 | BP3 | LCD Backplane #3. |
| 11 | $\overline{\text{LO}}\Omega/\text{A}$ | LCD Annunciator segment drive for low ohms resistance measurement and current measurement. |
| 12 | Ω/V | LCD Annunciator segment drive for resistance measurement and voltage measurement. |
| 13 | k/m/HOLD | LCD Annunciator segment drive for k ("kilo-Ohms"), m ("milliamps" and "millivolts") and HOLD mode. |
| 14 | BCP0 (One's digit) | LCD segment drive for "b," "c" segments and decimal point of least significant digit (LSD). |
| 15 | AGD0 | LCD segment drive for "a," "g," "d" segments of LSD. |
| 16 | FE0 | LCD segment drive for "f" and "e" segments of LSD. |
| 17 | NC | No connection. |
| 18 | BCP1 | LCD segment drive for "b," "c" segments and decimal point of 2nd LSD. |
| 19 | AGD1 | LCD segment drive for "a," "g," "d" segments of 2nd LSD. |
| 20 | FE1 | LCD segment drive for "f" and "e" segments of 2nd LSD. |
| 21 | BCP2 | LCD segment drive for "b," "c" segments and decimal point of 3rd LSD (hundred's digit). |
| 22 | AGD2 | LCD segment drive for "a," "g," "d" segments of 3rd LSD. |
| 23 | FE2 | LCD segment drive for "f," "e" segments of 3rd LSD. |
| 24 | BCP3 | LCD segment drive for "b," "c" segments and decimal point of MSD, (thousand's digit). |
| 25 | AC/-/AUTO | LCD annunciator segment drive for AC measurements, polarity, and auto-range operation. |
| 26 | -MEM/BATT | LCD annunciator segment drive for AC for low battery indication and memory (relative measurement). |
| 27 | ANNUNC | Square wave output at the backplane frequency, synchronized to BP1. ANNUNC can be used to control display annunciators. Connecting an LCD segment to ANNUNC turns it on; connecting it to its backplane turns it off. |
| 28 | V_{CC} | Positive battery supply connection. |
| 29 | COM | Analog circuit ground reference point. Nominally 3V below V_{CC} . |
| 30 | DEINT | De-integrate output. |
| 31 | RM_{REFL} | Ratiometric (resistance measurement) reference low voltage. |
| 32 | C_{REFL} | Reference capacitor negative terminal $\text{C}_{\text{REF}} = 0.1\mu\text{f}$. |
| 33 | C_{REFH} | Reference capacitor positive terminal $\text{C}_{\text{REF}} = 0.1\mu\text{f}$. |
| 34 | REFHI | Reference voltage for voltage and current measurement. Nominally 163.85mV. |
| 35 | ΩR1 | Standard resistor connection for 200 Ω full scale. |
| 36 | ΩR2 | Standard resistor connection for 2000 Ω full scale. |

TC818A

TABLE 2-1: PIN FUNCTION TABLE (CONTINUED)

| Pin Number (64-Pin PQFP) | Symbol | Description |
|-----------------------------|-------------------------------------|---|
| 37 | $\Omega R3$ | Standard resistor connection for 20k Ω full scale range. |
| 38 | $\Omega R4$ | Standard resistor connection for 200k Ω full scale range. |
| 39 | $\Omega R5$ | Standard resistor connection for 2000k Ω full scale. |
| 40 | VR3 | Voltage measurement \div 100 attenuator. |
| 41 | VR2 | Voltage measurement \div 10 attenuator. |
| 42 | VR5 | Voltage measurement \div 10,000 attenuator. |
| 43 | VR4 | Voltage measurement \div 1000 attenuator. |
| 44 | V_I | Unknown voltage input \div attenuator. |
| 45 | I_I | Unknown current input. |
| 46 | ACVL | Low output of AC-to-DC converter. |
| 47 | C_I | Integrator capacitor connection. Nominally 0.1 μ F. (Must have low dielectric absorption. Polypropylene dielectric suggested.) |
| 48 | NC | No connection. |
| 49 | C_{AZ} | Auto-zero capacitor connection. Nominally 0.1 μ F. |
| 50 | R_X | Unknown resistance input. |
| 51 | CFI | Input filter connection. |
| 52 | ADI | Negative input of internal AC-to-DC operational amplifier. |
| 53 | ADO | Output of internal AC-to-DC operational amplifier. |
| 54 | R Ω BUF | Active buffer output for resistance measurement. Integration resistor connection. Nominally 220k Ω . |
| 55 | RVIBUF | Active buffer output for voltage and current measurement. Integration resistor connection. Nominally 15k Ω . |
| 56 | ACVH | Positive output of AC-to-DC converter. |
| 57 | V_{SS} | Negative supply connection. Connect to negative terminal of 9V battery. |
| 58 | DGND | Internal logic digital ground. Ground connection for the logic "0" level. Nominally 4.7V below V_{CC} . |
| 59 | \overline{RANGE} | Input to set manual operation and change ranges. |
| 60 | \overline{HOLD} | Input to hold display. Connect to DGND to "FREEZE" display. |
| 61 | -MEM | Input to enter Memory Measurement mode for relative measurements. The two LSDs are stored and subtracted from future measurements. |
| 62 | DC(Ω)/ AC(LO Ω) | Input that selects AC or DC option during voltage/current measurements. For resistance measurements, the ohms or low power (voltage) ohms option can be selected. |
| 63 | \overline{I} | Input to select measurement. Connect to logic "0" (digital ground) for current measurement. |
| 64 | NC | No connection. |

3.0 DETAILED DESCRIPTION

3.1 Analog-to-Digital Converter (ADC)

The TC818A includes an integrating ADC with auto-ranging resolution of 2000 counts and manual range resolution of 3000 counts. Figure 3-1 shows a simplified schematic of the analog section. In Auto-Ranging mode, internal logic will adjust the input voltage or ohms attenuators so that measurements will always be made in the appropriate range.

Measurement ranges, logic control inputs, 3-1/2 digit LCD formatting, and other features are identical to the TC818A auto-ranging A/D converter. However, the TC818A is not pin compatible with, and is not a replacement for, the TC818A.

A display annunciator output (ANNUNC) can be used to customize the LCD. ANNUNC is a square wave at the backplane frequency. Connecting an annunciator segment to the ANNUNC driver turns the segment on; connecting the segment to its backplane turns it off.

FIGURE 3-1: TC818A ANALOG SECTION

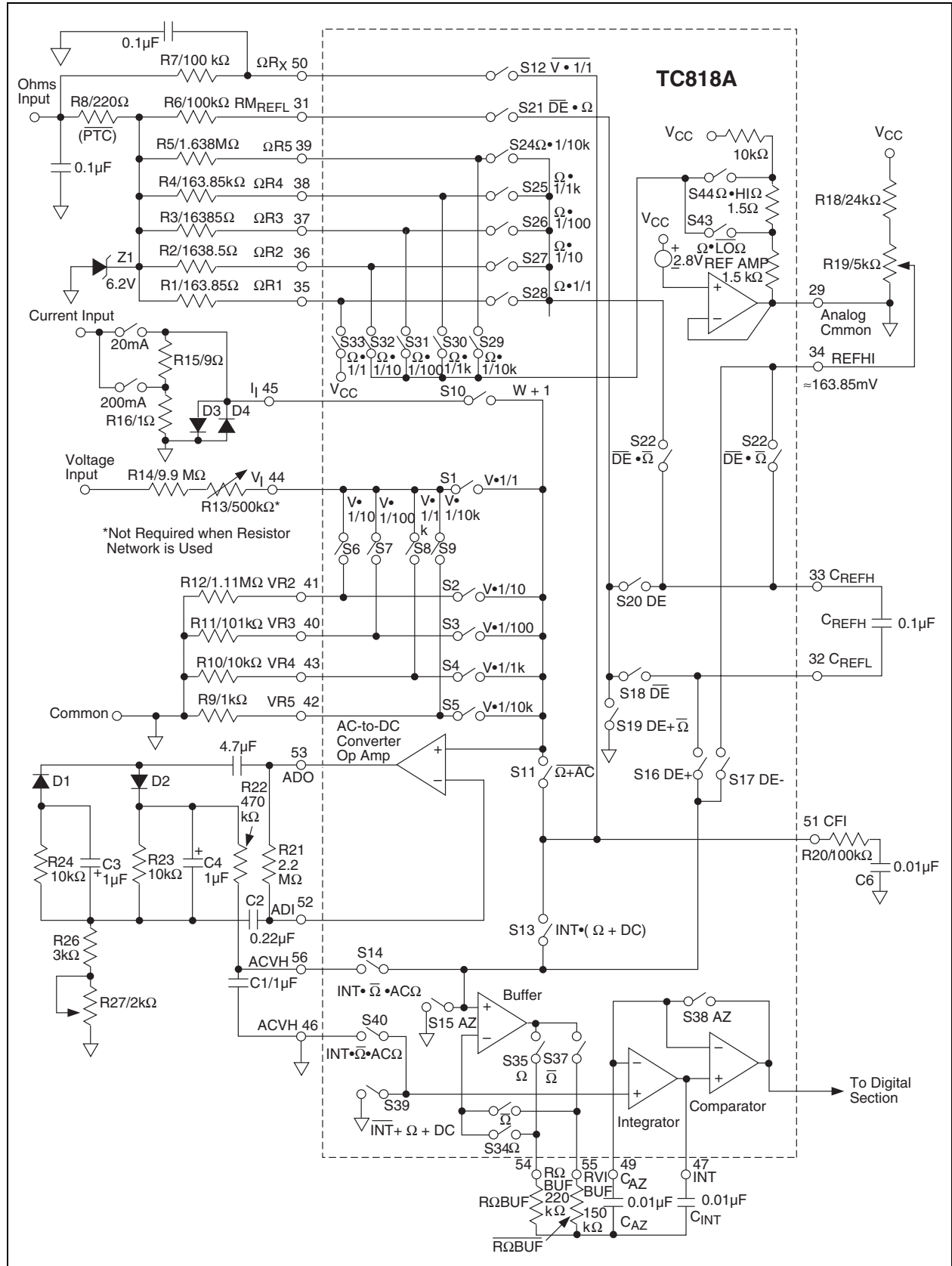

3.2 Resistance, Voltage, Current Measurement Selection

The TC818A is designed to measure voltage, current, and resistance. Auto-ranging is available for resistance and voltage measurements. The $\overline{\text{OHM}}$ (Pin 2) and $\overline{\text{I}}$ (Pin 63) input controls are normally pulled internally to V_{CC} .

By tying these pins to DGND (Pin 58), the TC818A is configured internally to measure resistance, voltage, or current. The required signal combinations are shown in Table 3-1.

TABLE 3-1: TC818A MEASUREMENT SELECTION LOGIC

| Function Select Pin 0 = Digital Ground 1 = Floating or Tied to V_{CC} | | Selected Measurement |
|---|--------------------------------|----------------------|
| $\overline{\text{OHM}}$ (Pin 2) | $\overline{\text{I}}$ (Pin 63) | |
| 0 | 0 | Voltage |
| 0 | 1 | Resistance |
| 1 | 0 | Current |
| 1 | 1 | Voltage |

Note 1: $\overline{\text{OHM}}$ and $\overline{\text{I}}$ are normally pulled internally high to V_{CC} (Pin 28). This is considered a logic "1".
2: Logic "0" is the potential at digital ground (Pin 58).

3.3 Resistance Measurements (Ohms and Low Power Ohms)

The TC818A can be configured to reliably measure in-circuit resistances shunted by semiconductor junctions. The TC818A Low Power Ohms Measurement mode limits the probe open circuit voltage. This prevents semiconductor junctions in the measured system from turning on.

In the Resistance Measurement mode, the $\Omega/\overline{\text{LO}}\Omega$ (Pin 62) input selects the Low Power Ohms Measurement mode. For low power ohms measurements, $\Omega/\overline{\text{LO}}\Omega$ (Pin 62) is momentarily brought LOW to digital ground potential. The TC818A sets up for a low power ohms measurement, with a maximum open circuit probe voltage of 0.35V above analog common. In the Low Power Ohms mode, an LCD display annunciator, $\overline{\text{LO}}\Omega$, will be activated. On power-up, the Low Power Ohms mode is not active.

If the Manual Operating mode has been selected, toggling $\Omega/\overline{\text{LO}}\Omega$ resets the TC818A back to the Auto-Range mode. In Manual mode, the decision to make a normal or low power ohms measurement should be made before selecting the desired range.

The low power ohms measurement is not available on the 200 Ω full scale range. Open circuit voltage on this range is below 2.8V. The standard resistance values are listed in Table 3-2.

R8, a positive temperature coefficient resistor, and the 6.2V zener, Z1, provide input voltage protection during ohms measurements.

TABLE 3-2: OHMS RANGE LADDER NETWORK

| Full-Scale Range | Standard Resistance | Low Power Ohms Mode |
|------------------|-------------------------|---------------------|
| 200 Ω | 163.85 Ω (R1) | NO |
| 2000 Ω | 1638.5k Ω (R2) | YES |
| 20k Ω | 16,385 Ω (R3) | YES |
| 200k Ω | 163,85 Ω (R4) | YES |
| 2,000k Ω | 1,638,500 Ω (R5) | YES |

3.4 Ratiometric Resistance Measurements

The TC818A measures resistance ratiometrically. Accuracy is set by the external standard resistors connected to Pin 35 through 39. A Low Power Ohms mode may be selected on all but the 200 Ω full scale range. The Low Power Ohms mode limits the voltage applied to the measured system. This allows accurate "in-circuit" measurements when a resistor is shunted by semiconductor junctions.

Full auto-ranging is provided. External precision standard resistors are automatically switched to provide the proper range.

Figure 3-2 shows a detailed block diagram of the TC818A, configured for ratiometric resistance measurements. During the signal integrate phase, the reference capacitor charges to a voltage inversely proportional to the measured resistance, R_X . Figure 3-3 shows that the conversion accuracy relies on the accuracy of the external standard resistors.

Normally, the required accuracy of the standard resistances will be dictated by the accuracy specifications of the users end product. Table 3-3 gives the equivalent ohms per count for various full scale ranges to allow users to judge the required resistor for accuracy.

TABLE 3-3: REFERENCE RESISTORS

| Full Scale Range | Reference Resistor | Ω/Count |
|------------------|--------------------|-----------------------|
| 200k | 163.85 | 0.1 |
| 2k | 1638.5 | 1 |
| 20k | 16385 | 10 |
| 200k | 163,850 | 100 |
| 2M | 1,638,500 | 1000 |

FIGURE 3-2: RATIOMETRIC RESISTANCE MEASUREMENT FUNCTIONAL DIAGRAM

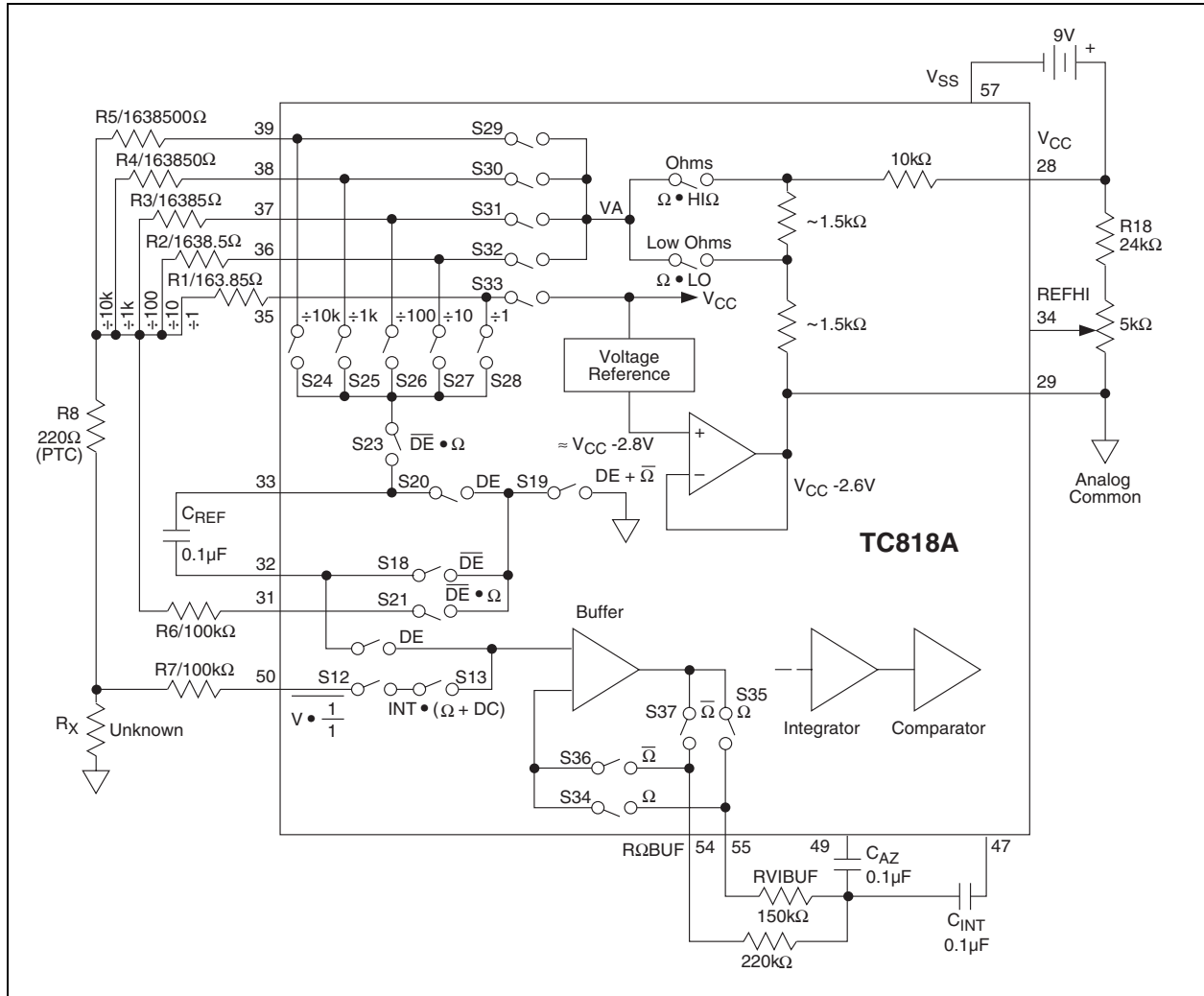
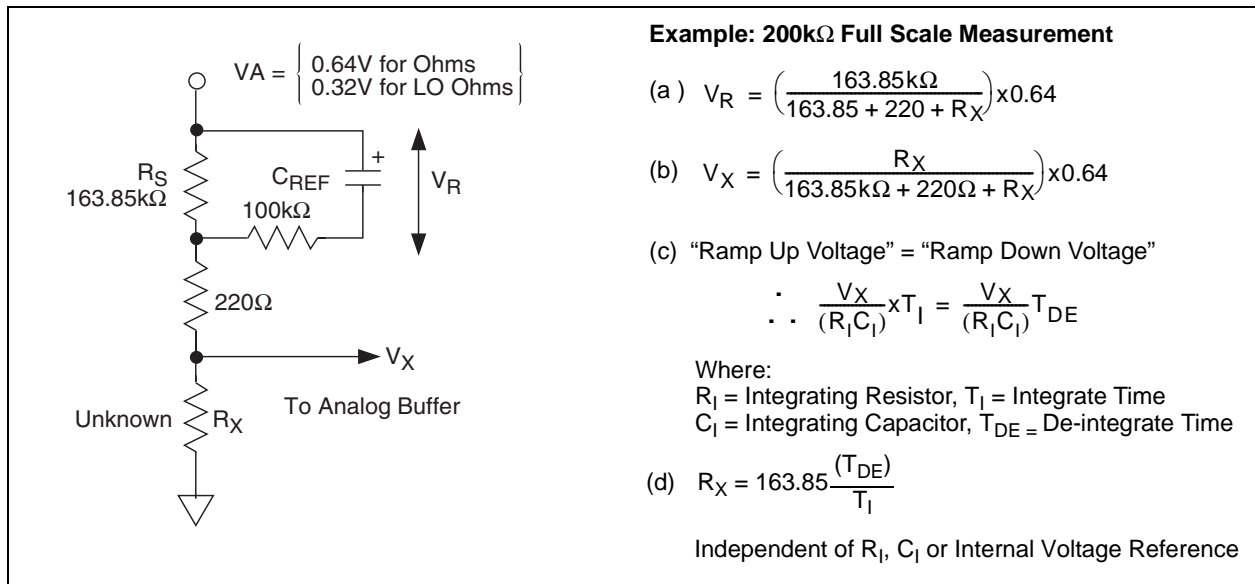

FIGURE 3-3: RESISTANCE MEASUREMENT ACCURACY SET BY EXTERNAL STANDARD RESISTOR



TC818A

3.5 Voltage Measurement

Resistive dividers are automatically changed to provide in range readings for 200mV to 2000V full scale readings (Figure 3-1). The input resistance is set by external resistors R14/R13. The divider leg resistors are R9-R12. The divider leg resistors give a 200mV signal V_I (Pin 44) for full scale voltages from 200mV to 2000V.

For applications which do not require a 10m Ω input impedance, the divider network impedances may be lowered. This will reduce voltage offset errors induced by switch leakage currents.

3.6 Current Measurement

The TC818A measures current only under manual range operation. The two user selectable, full scale ranges are: 20mA and 200mA. Select the current Measurement mode by holding the \bar{I} input (Pin 63) LOW at digital ground potential. The OHM input (Pin 2) is left floating or tied to the positive supply.

Two ranges are possible. The 20mA full scale range is selected by connecting the 20mA input (Pin 3) to digital ground. If left floating, the 200mA full scale range is selected.

External current-to-voltage conversion resistors are used at the current input (I_I input, Pin 45). For 20mA measurements, a 10 Ω resistor is used. The 200mA range requires a 1 Ω resistor; full scale is 200mV.

Printed circuit board trace resistance between analog common and R16 must be minimized. In the 200mA range, for example, a 0.05 trace resistance will cause a 5% current-to-voltage conversion error at I_I (Pin 45).

The extended resolution measurement option operates during current measurements.

To minimize rollover error, the potential difference between analog common (COM, Pin 29) and system common must be minimized.

3.7 AC-to-DC Measurements

In voltage and current measurements, the TC818A can be configured for AC measurements. An on-chip operational amplifier and external rectifier components perform the AC-to-DC conversion.

When power is first applied, the TC818A enters the DC Measurement mode. For AC measurements (current or voltage), AC/DC (Pin 62) is momentarily brought LOW to digital ground potential; the TC818A sets up for AC measurements, and the AC liquid crystal display annunciator activates. Toggling AC/DC LOW again returns the TC818A to DC operation.

If the Manual Operating mode has been selected, toggling AC/DC resets the TC818A back to the Auto-Range mode. In Manual mode operation, AC or DC should be selected first, then the desired range.

The minimum AC full scale voltage range is 2V. The DC full scale minimum voltage is 200mV.

AC current measurements are available on the 20mA and 200mA full scale current ranges.

3.8 Conversion Timing

The TC818A analog-to-digital converter uses the conventional dual slope integrating conversion technique, with an added phase that automatically eliminates zero offset errors. The TC818A gives a zero reading with a 0 volt input.

The TC818A is designed to operate with a low cost, readily available 32.768kHz crystal. It serves as a time-base oscillator crystal in many digital clocks. (See External Crystal Sources.)

The external clock is divided by two. The internal clock frequency is 16.348kHz, giving a clock period of 61.04 μ sec. The total conversion — auto-zero phase, signal integrate and reference de-integrate — requires 8000 clock periods or 488.3msec. There are approximately two complete conversions per second.

The integration time is fixed at 1638.5 clock periods or 100msec. This gives rejection of 50/60Hz AC line noise.

The maximum reference de-integrate time, representing a full scale analog input, is 3000 clock periods (183.1msec) during manual extended resolution operation. The 3000 counts are available in Manual mode, extended resolution operation only. In Auto-Ranging mode, the maximum de-integrate time is 2000 clock periods. The 1000 clock periods are added to the auto-zero phase. An auto-ranging or manual conversion takes 8000 clock periods. After a zero crossing is detected in the Reference De-integrate mode, the auto-zero phase is entered. Figure 3-4 shows the basic TC818A timing relationships.

FIGURE 3-4: BASIC TC818A CONVERSION TIMING

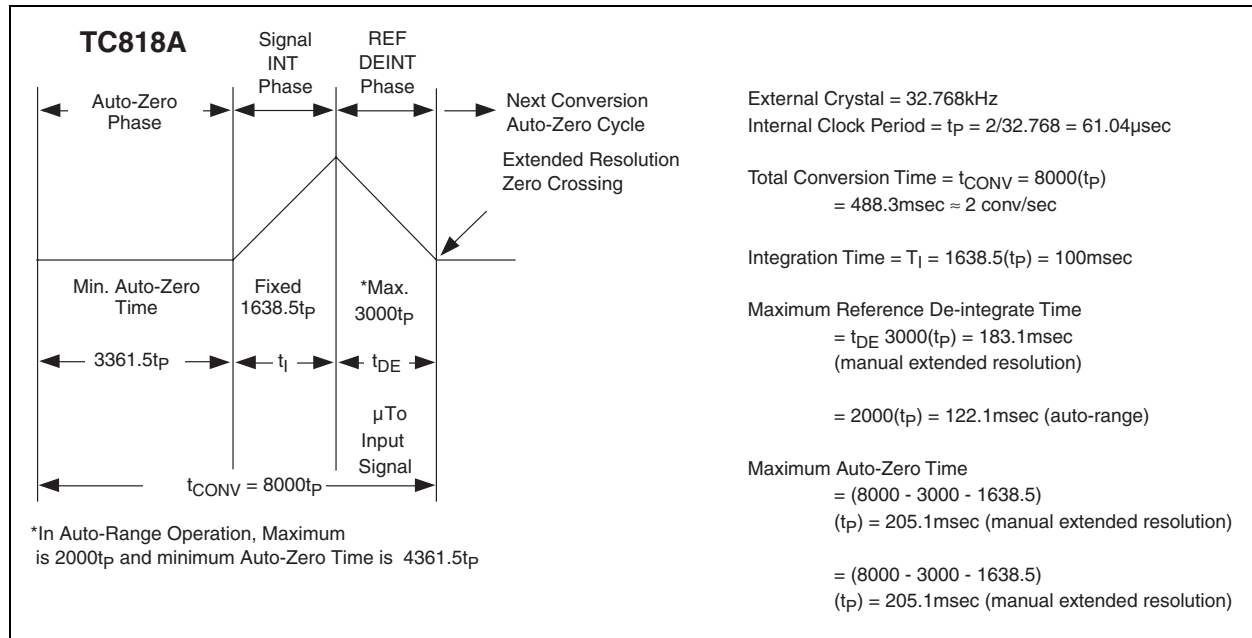

3.9 Manual Range Selection

The TC818A voltage and resistance auto-ranging feature can be disabled by momentarily bringing RANGE (Pin 59) to digital ground potential (Pin 58). When the change from auto-to-manual ranging occurs, the first manual range selected is the last range in the Auto-Ranging mode.

The TC818A power-up circuit initially selects auto-range operation. Once the manual range option is entered, range changes are made by momentarily grounding the RANGE control input. The TC818A remains in the Manual Range mode until the measurement function (voltage or resistance), or measurement option (AC/DC, Ω /LO Ω) changes. This causes the TC818A to return to auto-ranging operation.

The "Auto" LCD annunciator driver is active only in the Auto-Range mode.

Figure 3-5 shows typical operation where the manual range selection option is used. Also shown is the extended resolution display format. Also, see Figure 3-6 and Figure 3-7.

FIGURE 3-5: MANUAL RANGE SELECTION RESISTANCE MEASUREMENTS

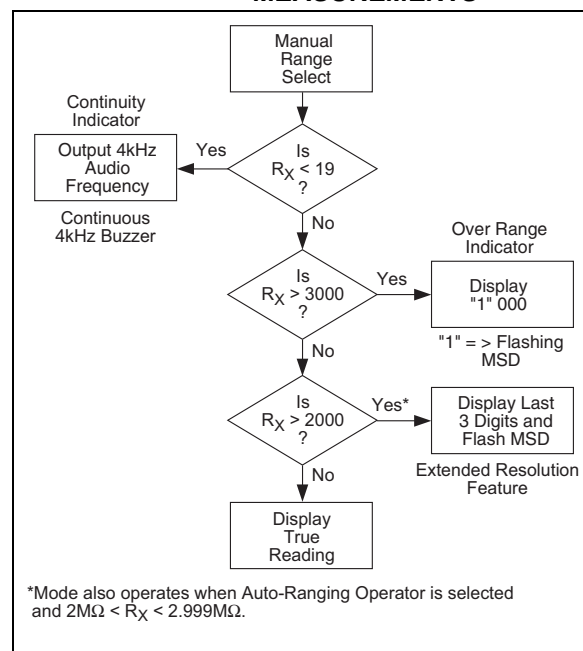

FIGURE 3-6: MANUAL RANGE SELECTION CURRENT MEASUREMENTS

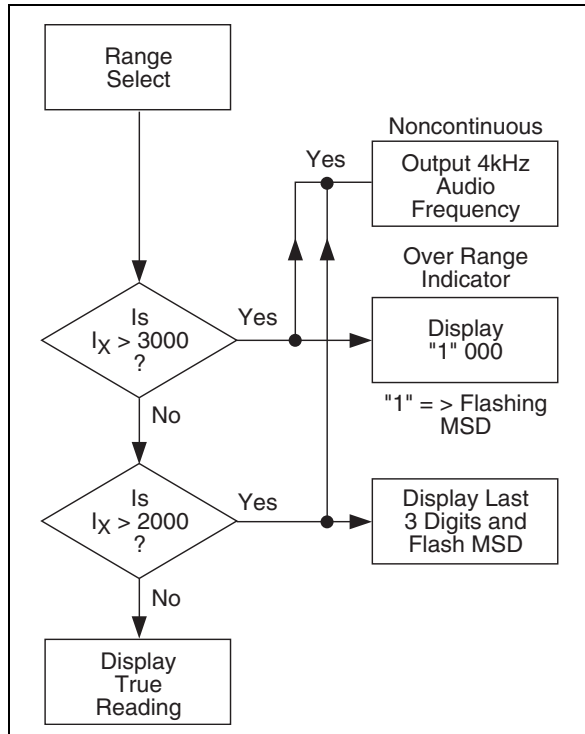
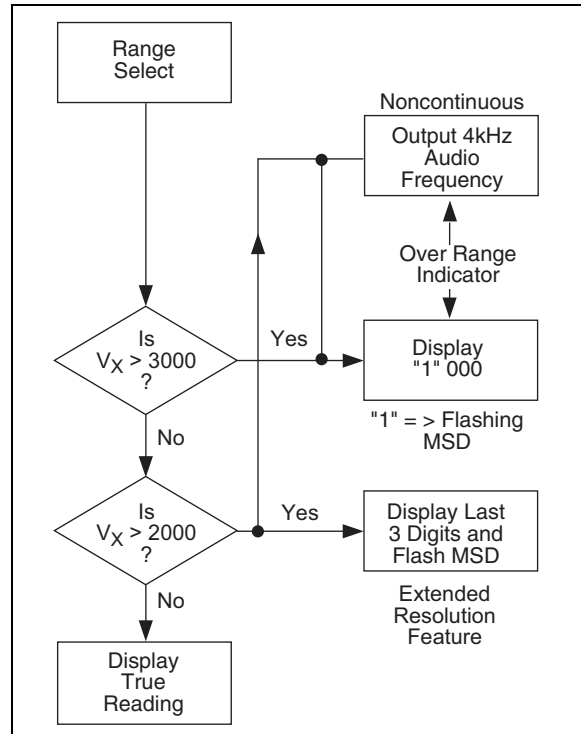

FIGURE 3-7: MANUAL RANGE SELECTION VOLTAGE MEASUREMENTS



3.10 Extended Resolution Manual Operation

When operated in the Manual Range mode, the TC818A extends resolution by 50% for current, voltage, and resistance measurements. Resolution increases to 3000 counts from 2000 counts. The extended resolution feature operates only in the 2000kΩ and 2000V ranges during auto-range operation.

In the Extended Resolution Operating mode, readings above 1999 are displayed with a blinking "1" most significant digit. The blinking "1" should be interpreted as the digit 2. The three least significant digits display data normally. The bar graph LCD will be fully extended.

An input over range condition causes the most significant digit (MSD) to blink and sets the three least significant digits (LSDs) to display "000." The buzzer output is enabled for input voltage and current signals with readings greater than 2000 counts in both manual and auto-range operations.

For resistance measurements, the buzzer signal does not indicate an over range condition. The buzzer is used to indicate continuity. Continuity is defined as a resistance reading less than 19 counts.

3.11 -MEM Operating Mode

Bringing -MEM (Pin 61) momentarily LOW configures the TC818A “-MEM” Operating mode. The -MEM LCD annunciator becomes active. In this Operating mode, subsequent measurements are made relative to the last two digits (≤ 99) displayed at the time MEM is LOW. This represents 5% of full scale. The last two significant digits are stored and subtracted from all the following input conversions.

The following examples clarify operation:

EXAMPLE 3-1: IN AUTO-RANGING

| | |
|------------|---|
| $R_I(N)$ | = 18.21k Ω (20k Ω Range) = \geq Display 18.21k Ω |
| MEM | = \geq Store 0.21k Ω |
| $R_I(N+1)$ | = 19.87k Ω (20k Ω Range) |
| | = \geq Display 19.87 - 0.21 = 19.66k Ω |
| $R_I(N+2)$ | = 22.65k Ω (200k Ω Range) |
| | = \geq Display 22.7k Ω and MEM disappears |

EXAMPLE 3-2: IN FIXED RANGE (200 FULL SCALE)

| | |
|------------|---|
| $R_I(N)$ | = 18.21k Ω = \geq Display 18.2k Ω |
| MEM | = \geq Store 8.2 Ω |
| $R_I(N+1)$ | = 36.7 Ω |
| | = \geq Display 36.7 - 8.2 = 28.5 Ω |
| $R_I(N+2)$ | = 5.8 Ω |
| | = \geq Display 5.8-8.2 = -2.4 Ω * |

*Will display minus resistance if following input is less than offset stored at fixed range.

EXAMPLE 3-3: IN FIXED RANGE 20V FULL SCALE

| | |
|------------|--|
| $V_I(N)$ | = 0.51V = \geq Display 0.51V |
| MEM | = \geq Store 0.51V |
| $V_I(N+1)$ | = 3.68V |
| | = \geq Display 3.68 - 0.51 = 3.17V |
| $V_I(N+2)$ | = 0.23V |
| | = \geq Display 0.23 - 0.51 = -0.28V |
| $V_I(N+3)$ | = -5.21V |
| | = \geq Display -5.21 - 0.51 = -5.72V |

On power-up, the “-MEM” mode is not active. Once the “-MEM” is entered, bringing MEM LOW again returns the TC818A to normal operation.

The “-MEM” mode is also cancelled whenever the measurement type (resistance, voltage, current $\overline{AC/DC}$, $\Omega/\overline{LO\Omega}$) or range is changed. The LCD -MEM annunciator will be off in normal operation.

In the auto-range operation, if the following input signal cannot be converted on the same range as the stored value, the “-MEM” mode is cancelled. The LCD annunciator is turned OFF.

The “-MEM” Operating mode can be very useful in resistance measurements when lead length resistance would cause measurement errors.

3.12 Automatic Range Selection Operation

When power is first applied, the TC818A enters the auto-range operating state. The Auto-Range mode may be entered from Manual mode by changing the measurement function (resistance or voltage), or by changing the measurement option ($\overline{AC/DC}$, $\Omega/\overline{LO\Omega}$).

The automatic voltage range selection begins on the most sensitive scale first: 200mV for DC or 2V for AC measurements. The voltage range selection flow chart is shown in Figure 3-8.

Internal input protection diodes to V_{CC} (Pin 28) and V_{SS} (Pin 57) clamp the input voltage. The external 10M Ω input resistance (see R14 and R13 of Functional diagram) limits current safely in an over range condition.

The voltage range selection is designed to maximize resolution. For input signals less than 9% of full scale (count reading <180), the next most sensitive range is selected.

An over range voltage input condition is flagged whenever the internal count exceeds 2000, by activating the buzzer output (Pin 4). This 4kHz signal can directly drive a piezo electric acoustic transducer. An out of range input signal causes the 4kHz signal to be on for 122msec, off for 122msec, on for 122msec and off for 610msec (see Figure 3-14).

During voltage auto-range operation, the extended resolution feature operates on the 2000V range only (see Extended Resolution Operating mode discussion).

The resistance automatic range selection procedure is shown in Figure 3-9. The 200 Ω range is the first range selected, unless the LOW ohms resistance measurement option is selected. In LOW ohms operation, the first full scale range tried is 2k Ω .

The resistance range selected maximizes sensitivity. If the conversion results in a reading less than 180, the next most sensitive full scale range is tried.

If the conversion is less than 19 in auto-range operation, a continuous 4kHz signal is output at BUZ (Pin 4). An over range input does not activate the buzzer.

Out-of-range input conditions are displayed by a blinking MSD with the three LSDs set to “000.”

The extended resolution feature operates only on the 2000k Ω and 2000V full scale range during auto-range operation. A blinking “1” most significant digit is interpreted as the digit 2. The three least significant digits display data normally.

TC818A

FIGURE 3-8: AUTO-RANGE OPERATION: VOLTAGE MEASUREMENT

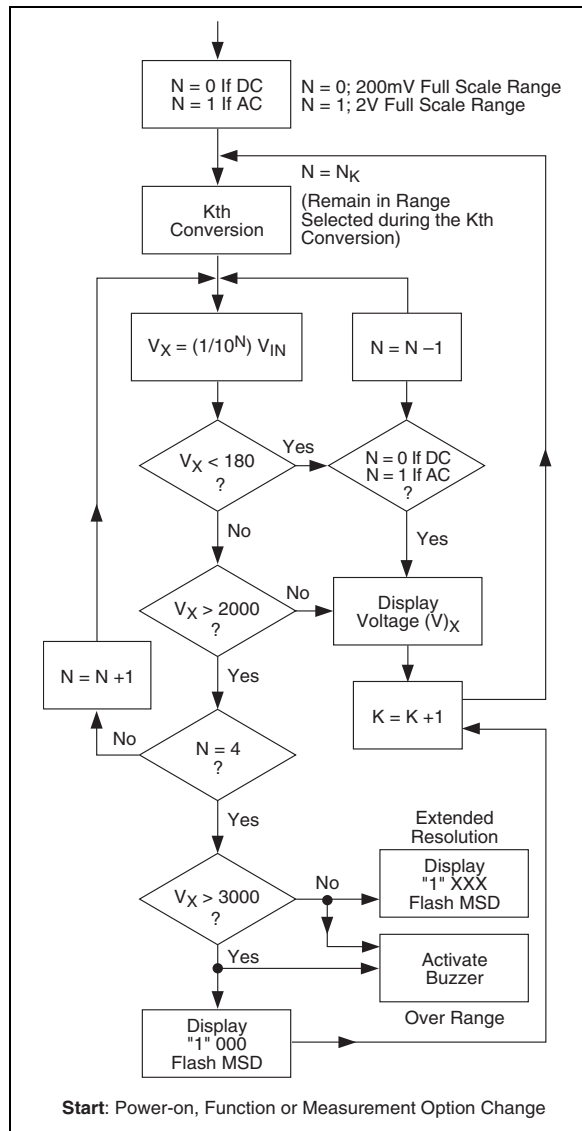
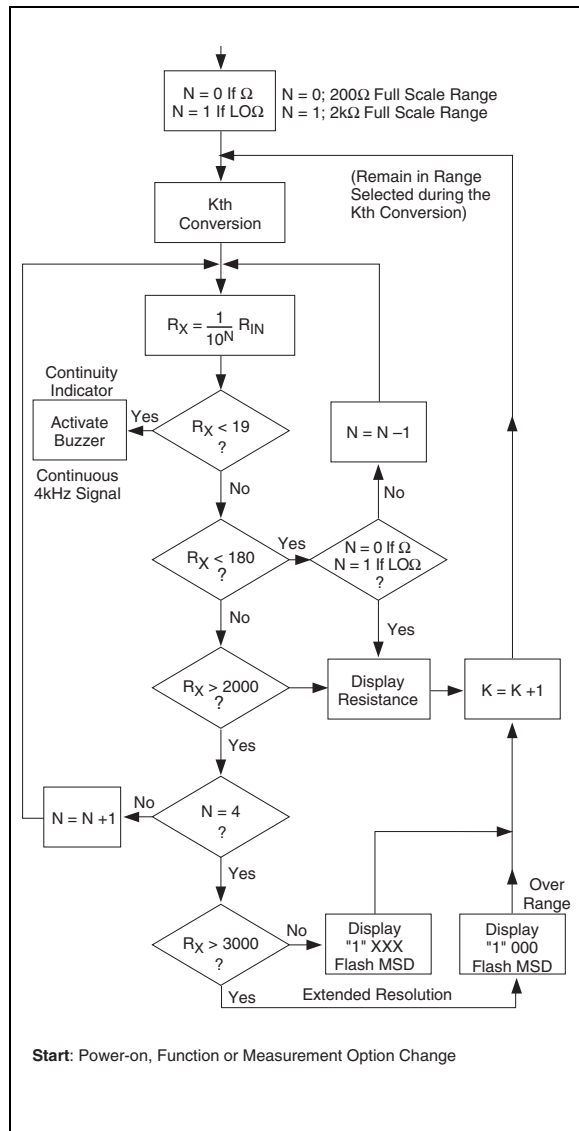

FIGURE 3-9: AUTO-RANGE OPERATION: RESISTANCE MEASUREMENT



3.13 Low Battery Detection Circuit

The TC818A contains a low battery detector. When the 9V battery supply has been depleted to a 7V nominal value, the LCD low battery annunciator is activated.

The low battery detector is shown in Figure 3-10. The low battery annunciator remains OFF with the battery supply greater than 0.7V. The annunciator is ON before the supply battery has reached 6.3V.

FIGURE 3-10: LOW BATTERY DETECTOR

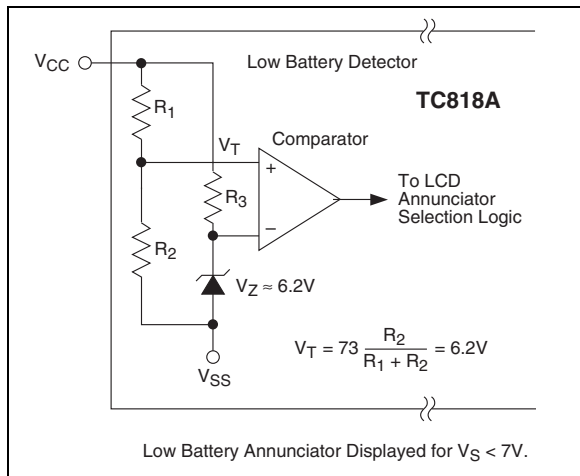

3.14 Triplex Liquid Crystal Display (LCD) Drive

The TC818A directly drives a triplexed liquid crystal display (LCD) using 1/3 bias drive. All numeric data, decimal point, polarity and function annunciator drive signals are developed by the TC818A.

The LCDs must be driven with an AC signal having zero DC component, for long display life. The liquid crystal polarization is a function of the RMS voltage appearing across the backplane and segment driver. The peak drive signal applied to the LCD is:

$$V_{CC} - V_{DISP}$$

For example, if V_{DISP} is set at a potential 3V below V_{CC} , the peak drive signal is:

$$V_P = V_{CC} - V_{DISP} = 3V$$

An "OFF" LCD segment has an RMS voltage of $V_P/3$ across it, or 1 volt. An "ON" segment has a $0.63V_P$ signal across it or 1.92V for $V_{CC} - V_{DISP} = 3V$.

Since the V_{DISP} pin is available, the user may adjust the "ON" and "OFF" LCD levels for various manufacturers' displays, by changing V_P signal across it, or 1.92V for $V_{DISP} = 3V$.

"OFF" segments may become visible at high LCD operating temperatures. A voltage with a -5 to -20mV/°C temperature coefficient can be applied to V_{DISP} to accommodate the liquid crystal temperature operating characteristics, if necessary.

The TC818A internally generates two intermediate LCD drive potentials (V_H and V_L) from a resistive divider (Figure 3-11) between V_{CC} and V_{DISP} . The latter impedance is approximately 150kΩ. This drive method is commonly known as 1/3 bias. With V_{DISP} connected to digital ground, $V_P \approx 5.0V$.

The intermediate levels are needed so that drive signals giving RMS "ON" and "OFF" levels can be generated. Figure 3-12 shows a typical drive signal and the resulting waveforms for "ON" and "OFF" RMS voltage levels across a selected LCD element.

FIGURE 3-11: 1/3 BIAS LCD DRIVE

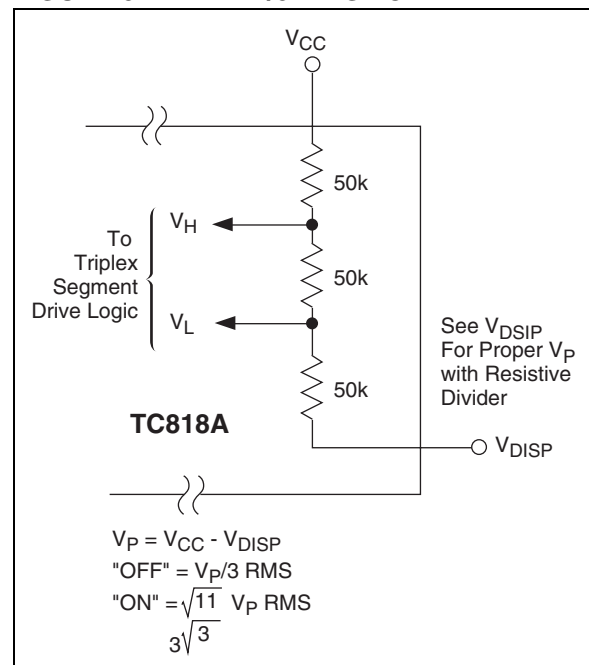

3.15 Liquid Crystal Displays (LCDs)

Most users will design their own custom LCD. However, for prototyping purposes, a standard display is available from Varitronix, Ltd. This prototype display configuration is shown in Figure 3-13 and Table 3-4.

Varitronix Ltd.
9/F Liven House, 61-63, King Yip Street
Kwun Tong, Hong Kong
Tel: (852)3-410286
Fax: (852)34-39555
Part No.: VIM-328-DP

USA Office:
VL Electronics, Inc.
3171 LOs Feliz Blvd, #303
Los Angeles, CA 90039
Tel: (213) 738-8700

TC818A

FIGURE 3-12: TRIPLEX LCD DRIVE WAVEFORMS

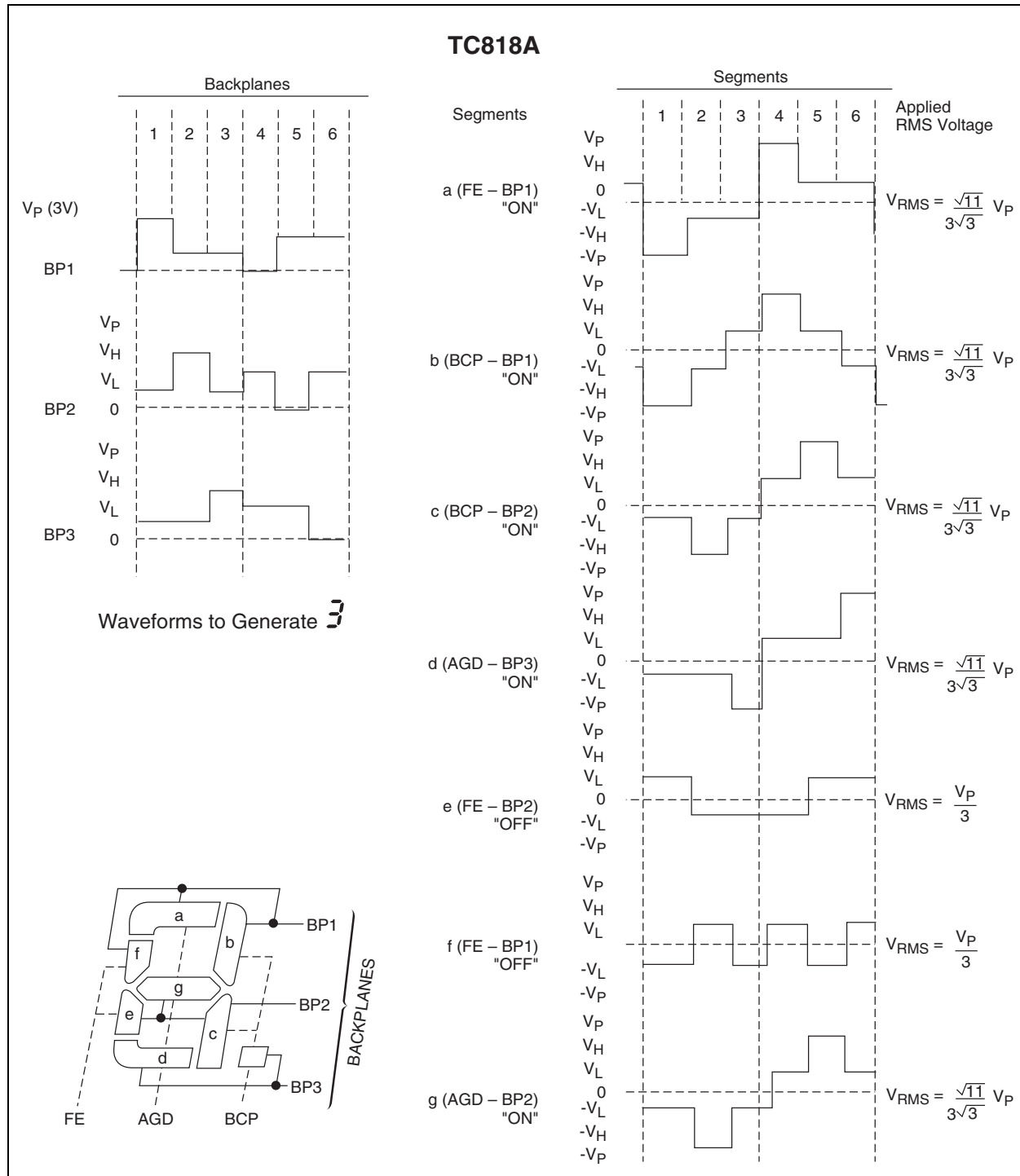

3.16 External Crystal

The TC818A is designed to operate with a 32,768Hz crystal. This frequency is internally divided by two to give a 61.04µsec clock period. One conversion takes 8000 clock periods or 488.3msec (≈ 2 conversions/second). Integration time is 1638.5 clock periods or 100msec.

The 32kHz quartz crystal is readily available and inexpensive. The 32kHz crystal is commonly used in digital clocks and counters.

Several crystal sources exist. A partial listing is:

- Statek Corporation
512 N. Main
Orange, CA 92668
(714) 639-7810
TWX: 910-593-1355
TELEX: 67-8394
- Fox Electronics
5570 Enterprise Parkway
Fort Myers, FL 33905
(941) 693-0099

Contact manufacturer for full specifications.

FIGURE 3-13: TYPICAL LCD CONFIGURATION, TC818A TRIPLEX

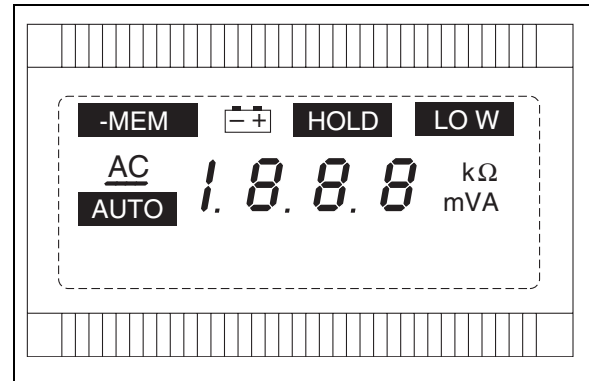

TABLE 3-4: TYPICAL LCD CONFIGURATION

| PAD | BP1 | BP2 | BP3 | PAD | BP1 | BP2 | BP3 |
|-----|-----|-----|-------|-----|------|------|------|
| 1 | — | — | SCALE | 19 | — | — | BP3 |
| 2 | X0 | X1 | X2 | 20 | — | BP2 | — |
| 3 | X5 | X4 | X3 | 21 | BP1 | — | — |
| 4 | X6 | X7 | X8 | 22 | — | LOW | A |
| 5 | X11 | X10 | X9 | 23 | — | W | V |
| 6 | X12 | X13 | X14 | 24 | HOLD | k | m |
| 7 | X17 | X16 | X15 | 25 | 4B | 4C | — |
| 8 | X18 | X19 | X20 | 26 | 4A | 4G | 4D |
| 9 | X23 | X22 | X21 | 27 | 4F | 4E | — |
| 10 | X24 | X25 | X26 | 28 | 3B | 3C | 3P |
| 11 | X29 | X28 | X27 | 29 | 3A | 3G | 3D |
| 12 | X30 | X31 | X32 | 30 | 3F | 3E | — |
| 13 | X35 | X34 | X33 | 31 | 2B | 2C | 2P |
| 14 | X36 | X37 | X38 | 32 | 2A | 2G | 2D |
| 15 | — | X40 | X39 | 33 | 2A | 2G | 2D |
| 16 | BPI | — | — | 34 | 1B | 1G | 1P |
| 17 | — | BP2 | — | 35 | Z | -MEM | — |
| 18 | — | — | BP3 | 36 | AC | y | AUTO |

TC818A

3.17 "Buzzer" Drive Signal

The BUZ output (Pin 4) will drive a piezo electric audio transducer. The signal is activated to indicate an input over range condition for current and voltage measurements, or continuity during resistance measurements.

During a resistance measurement, a reading less than 19 on any full scale range causes a continuous 4kHz signal to be output. This is used as a continuity indication.

A voltage or current input measurement over range is indicated by a noncontinuous 4kHz signal at the BUZ output. The LCD most significant digit also flashes and the three least significant digits are set to display zero. The buzzer drive signal for over range is shown in

Figure 3-14. The BUZ output is active for any reading over 2000 counts in both manual and auto-range operation. The buzzer is activated during an extended resolution measurement.

The BUZ signal swings from V_{CC} (Pin 28) to DGND (Pin 58). The signal is at V_{CC} when not active.

The BUZ output is also activated for 15ms whenever a range change is made in auto-range or manual operation. Changing the type of measurement (voltage, current, or resistance), or measurement option (AC/DC, Ω /LO Ω), also activates the buzzer output for 15msec. A range change during a current measurement will not activate the buzzer output.

FIGURE 3-14: TC818A TIMING WAVEFORM FOR BUZZER OUTPUT

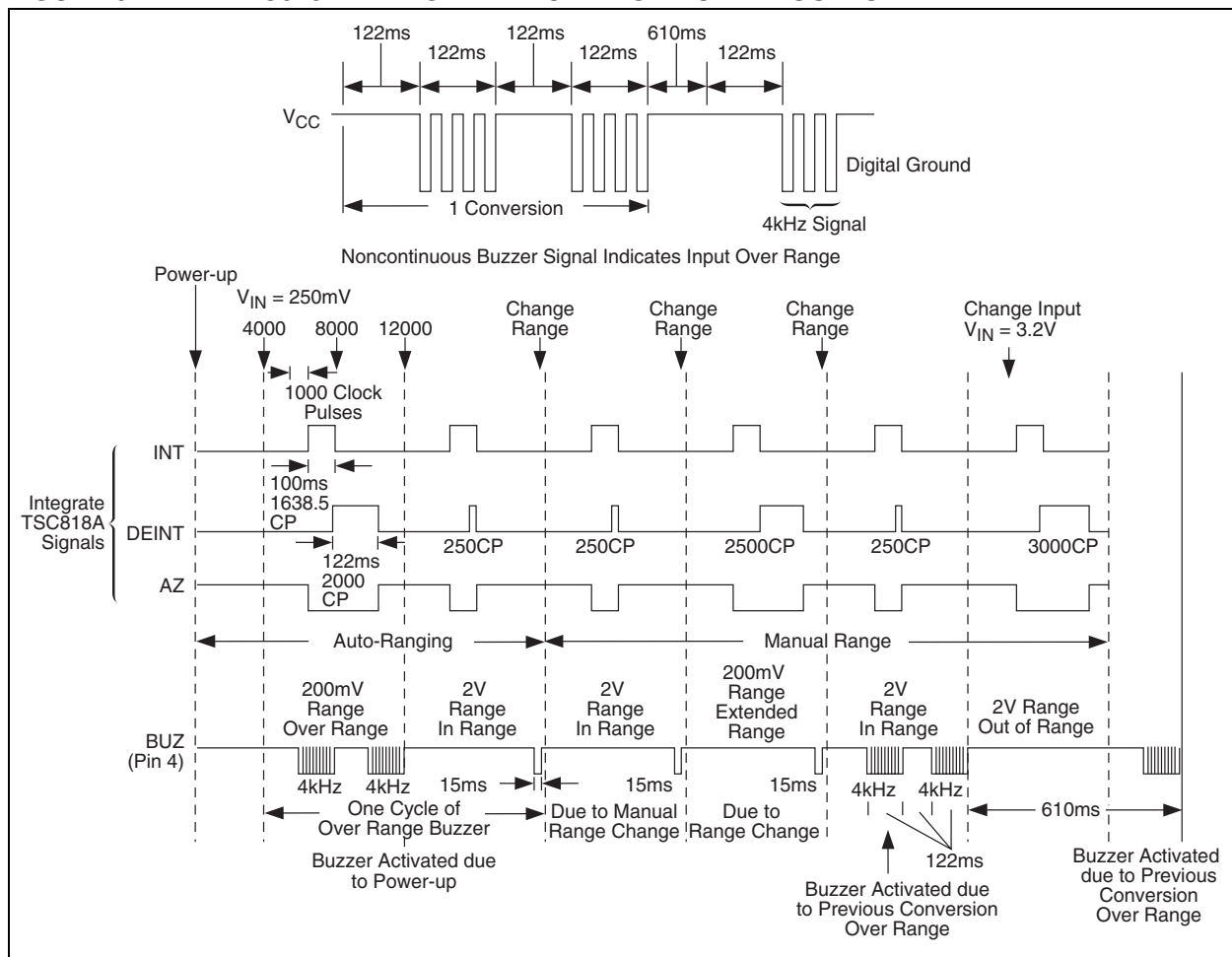

Vendors for piezo electric audio transducers are:

- Gulton Industries
Piezo Products Division
212 Durham Avenue
Metuchen, New Jersey 08840
(201) 548-2800
Typical P/Ns: 102-95NS, 101-FB-00
- Taiyo Yuden (USA) Inc.
Arlington Center
714 West Algonquin Road
Arlington Heights, Illinois 60005
Typical P/Ns: CB27BB, CB20BB, CB355BB

3.18 Display Decimal Point Selection

The TC818A provides a decimal point LCD drive signal. The decimal point position is a function of the selected full scale range, as shown in Table 3-5.

TABLE 3-5: DECIMAL POINT SELECTION

| Full Scale Range | 1 * 9 | * 9 | * 9 |
|-----------------------|-------|-----|-----|
| | DP3 | DP2 | DP1 |
| 2000V, 2000k Ω | OFF | OFF | OFF |
| 200V, 200k Ω | OFF | OFF | ON |
| 20V, 20k Ω | OFF | ON | OFF |
| 2V, 2k Ω | ON | OFF | OFF |
| 200V, 200 Ω | OFF | OFF | ON |
| 200mV, 200 Ω | OFF | OFF | ON |
| 20mA | OFF | ON | OFF |
| 200mA | OFF | OFF | ON |

3.19 AC-to-DC Converter Operational Amplifier

The TC818A contains an on-chip operational amplifier that may be connected as a rectifier for AC-to-DC voltage and current measurements. Typical operational amplifier characteristics are:

- Slew Rate: 1V/ μ sec
- Unity Gain Bandwidth: 0.4MHz
- Open Loop Gain: 44dB
- Output Voltage Swing (Load = 10k Ω) \pm 1.5V (Referenced to Analog Common)

When the AC measurement option is selected, the input buffer receives an input signal through switch S14, rather than switch S11 (see Figure 3-1). With external circuits, the AC Operating mode can be used to perform other types of functions within the constraints of the internal operational amplifier. External circuits that perform true RMS conversion, or a peak hold function, are typical examples.

3.20 Component Selection

3.20.1 INTEGRATION RESISTOR SELECTION

The TC818A automatically selects one of two external integration resistors. RVIBUF (Pin 55) is selected for voltage and current measurement. R Ω BUF (Pin 54) is selected for resistance measurements.

3.20.2 RVIBUF SELECTION (PIN 55)

In auto-range operation, the TC818A operates with a 200mV maximum full scale potential at V_I (Pin 44). Resistive dividers at VR2 (Pin 41), VR3 (Pin 40), VR4 (Pin 43), and VR5 (Pin 42) are automatically switched to maintain the 200V full scale potential.

In Manual mode, the Extended Operating mode is activated, giving a 300mV full scale potential at V_I (Pin 44).

The integrator output swing should be maximized, but saturations must be avoided. The integrator will swing within 0.45V of V_{CC} (Pin 28) and 0.5V of V_{SS} (Pin 57) without saturating. A \pm 2V swing is suggested. The value of RVIBUF is easily calculated, assuming a worst case extended resolution input signal:

Where:

$$\begin{aligned}
 V_{INT} &= \text{Integrator swing} = \pm 2V \\
 t_i &= \text{Integration time} = 100\text{msec} \\
 C_i &= \text{Integration capacitor} = 0.1\mu\text{F} \\
 V_{MAX} &= \text{Maximum input at } V_I = 300\text{mV}
 \end{aligned}$$

EQUATION 3-1:

$$RVIBUF = \frac{V_{MAX}(T_i)}{V_{INT}(C_i)} = 150k\Omega$$

3.20.3 R Ω BUF SELECTION (PIN 54)

In ratiometric resistance measurements, the signal at R_X (Pin 50) is always positive, with respect to analog common. The integrator swings negative.

The worst case integrator swing is for the 200 Ω range with the manual, extended resolution option.

The input voltage, V_X (Pin 50) is easily calculated (see Figure 3-15).

TC818A

FIGURE 3-15: R Ω CALCULATION (200 Ω MANUAL OPERATION)

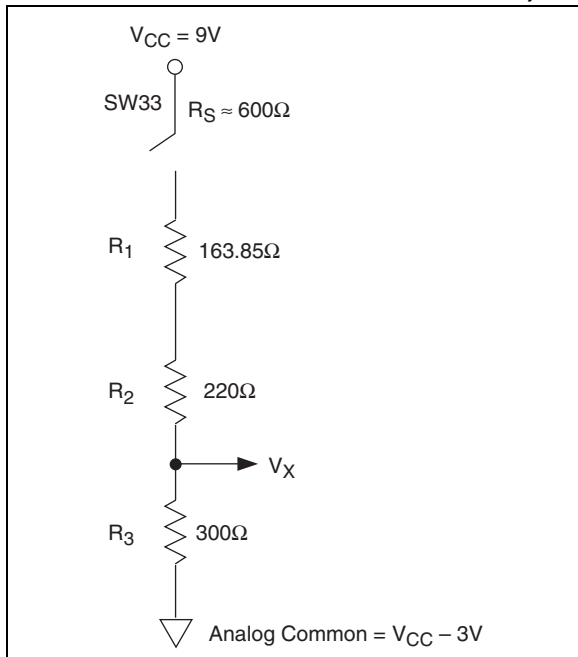

Where:

$$\begin{aligned} V_{ANCOM} &= \text{Potential at Analog Common} \approx 2.7V \\ R_S &= 220\Omega \\ R_1 &= 163.85\Omega \\ R_X &= 300\Omega \\ R_S &= \text{Internal switch 33 resistance} \approx 600\Omega \end{aligned}$$

EQUATION 3-2:

$$R_{\Omega}BUF = \frac{(V_{CC} - V_{ANCOM})R_X}{(R_X + R_S + R_1 + R_2)} = 0.63V$$

For a 3.1V integrator swing, the value of R Ω BUF is easily calculated:

Where:

$$\begin{aligned} V_{INT} &= \text{Integrator swing} = 3.1V \\ T_1 &= \text{Integration time} = 100\text{msec} \\ C_1 &= \text{Integration capacitor} = 0.1\mu F \\ R_{XMAX} &= 300\Omega \\ V_{XMAX} &= 700\text{mV} \end{aligned}$$

EQUATION 3-3:

$$R_{\Omega}BUF = \frac{V_{XMAX}(T_1)}{C_1(V_{INT})} = 200k\Omega$$

With a low battery voltage of 6.6V, analog common will be approximately 3.6V above the negative supply terminal. With the integrator swinging down from analog common toward the negative supply, a 3.1V swing will set the integrator output to 0.5V above the negative supply.

3.21 Capacitors - C_{INT}, C_{AZ} and C_{REF}

The integration capacitor, C_{INT}, must have low dielectric absorption. A 0.1 μ F polypropylene capacitor is suggested. The auto-zero capacitor, C_{AZ}, and reference capacitor, C_{REF}, should be selected for low leakage and dielectric absorption. Polystyrene capacitors are good choices.

3.22 Reference Voltage Adjustment

The TC818A contains a low temperature drift internal voltage reference. The analog common potential (Pin 29) is established by this reference. Maximum drift is a low 75ppm/ $^{\circ}$ C. Analog common is designed to be approximately 2.6V below V_{CC} (Pin 28). A resistive divider (R18/R19, Functional Diagram) sets the TC818A reference input voltage (REFHI, Pin 34) to approximately 163.85mV.

With an input voltage near full scale on the 200mV range, R19 is adjusted for the proper reading.

3.23 Display Hold Feature

The LCD will not be updated when \overline{HOLD} (Pin 60) is connected to GND (Pin 58). Conversions are made, but the display is not updated. A HOLD mode LCD annunciator is activated when HOLD is low.

The LCD \overline{HOLD} annunciator is activated through the triplex LCD driver signal at Pin 13.

3.24 Flat Package Socket

Sockets suitable for prototype work are available. A USA source is:

- Nepenthe Distribution
2471 East Bayshore, Suite 520
Palo Alto, CA 94303
(415) 856-9332
TWX: 910-373-2060
"CBQ" Socket, Part No. IC51-064-042

3.25 Resistive Ladder Networks

Resistor attenuator networks for voltage and resistance measurements are available from:

- Caddock Electronics
1717 Chicago Avenue
Riverside, CA 92507
Tel: (714) 788-1700
TWX: 910-332-6108

TABLE 3-6: RESISTIVE LADDER NETWORKS

| Attenuator Accuracy | Attenuator Type | Caddock Part Number |
|---------------------|-----------------|---------------------|
| 0.1% | Voltage | 1776-C441 |
| 0.25% | Voltage | 1776-C44 |
| 0.25% | Resistance | T1794-204-1 |

4.0 PACKAGING INFORMATION

4.1 Package Marking Information

Package marking data not available at this time.

4.2 Taping Form

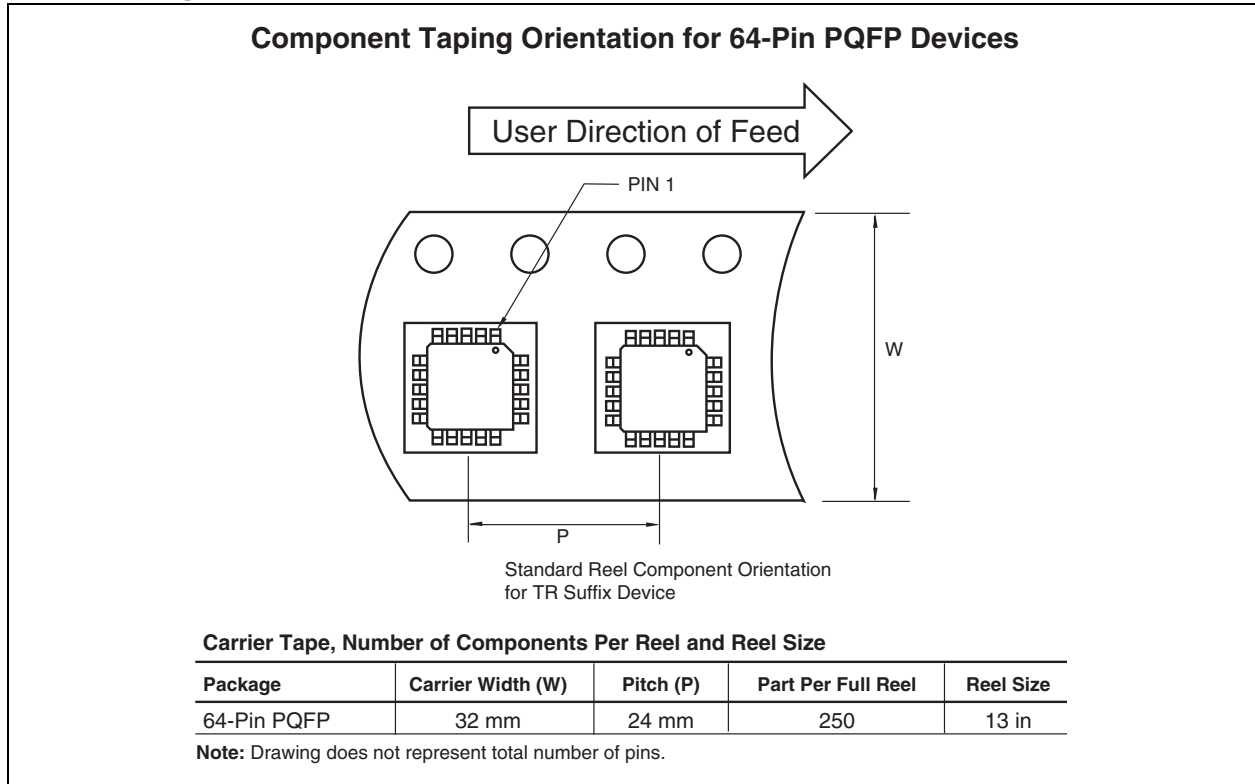

4.3 Package Dimensions

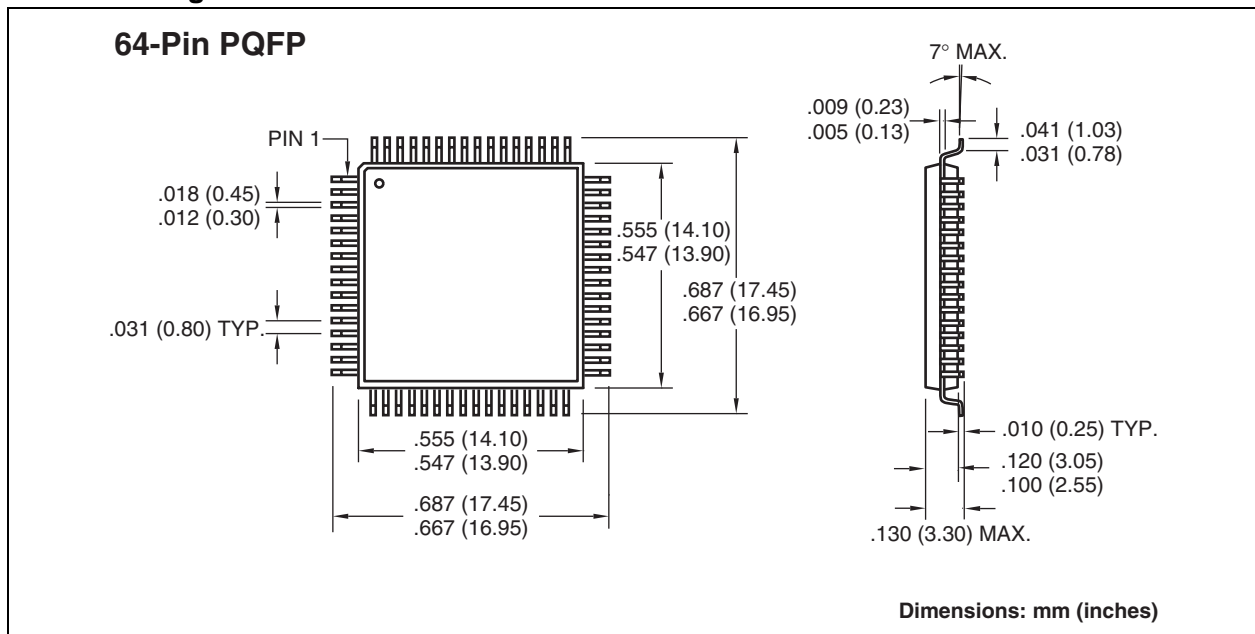

SALES AND SUPPORT

Data Sheets

Products supported by a preliminary Data Sheet may have an errata sheet describing minor operational differences and recommended workarounds. To determine if an errata sheet exists for a particular device, please contact one of the following:

1. Your local Microchip sales office
2. The Microchip Corporate Literature Center U.S. FAX: (480) 792-7277
3. The Microchip Worldwide Site (www.microchip.com)

Please specify which device, revision of silicon and Data Sheet (include Literature #) you are using.

New Customer Notification System

Register on our web site (www.microchip.com/cn) to receive the most current information on our products.

Note the following details of the code protection feature on Microchip devices:

- Microchip products meet the specification contained in their particular Microchip Data Sheet.
- Microchip believes that its family of products is one of the most secure families of its kind on the market today, when used in the intended manner and under normal conditions.
- There are dishonest and possibly illegal methods used to breach the code protection feature. All of these methods, to our knowledge, require using the Microchip products in a manner outside the operating specifications contained in Microchip's Data Sheets. Most likely, the person doing so is engaged in theft of intellectual property.
- Microchip is willing to work with the customer who is concerned about the integrity of their code.
- Neither Microchip nor any other semiconductor manufacturer can guarantee the security of their code. Code protection does not mean that we are guaranteeing the product as "unbreakable."

Code protection is constantly evolving. We at Microchip are committed to continuously improving the code protection features of our products. Attempts to break Microchip's code protection feature may be a violation of the Digital Millennium Copyright Act. If such acts allow unauthorized access to your software or other copyrighted work, you may have a right to sue for relief under that Act.

Information contained in this publication regarding device applications and the like is provided only for your convenience and may be superseded by updates. It is your responsibility to ensure that your application meets with your specifications. MICROCHIP MAKES NO REPRESENTATIONS OR WARRANTIES OF ANY KIND WHETHER EXPRESS OR IMPLIED, WRITTEN OR ORAL, STATUTORY OR OTHERWISE, RELATED TO THE INFORMATION, INCLUDING BUT NOT LIMITED TO ITS CONDITION, QUALITY, PERFORMANCE, MERCHANTABILITY OR FITNESS FOR PURPOSE. Microchip disclaims all liability arising from this information and its use. Use of Microchip's products as critical components in life support systems is not authorized except with express written approval by Microchip. No licenses are conveyed, implicitly or otherwise, under any Microchip intellectual property rights.

Trademarks

The Microchip name and logo, the Microchip logo, Accuron, dsPIC, KEELOQ, microID, MPLAB, PIC, PICmicro, PICSTART, PRO MATE, PowerSmart, rPIC, and SmartShunt are registered trademarks of Microchip Technology Incorporated in the U.S.A. and other countries.

AmpLab, FilterLab, Migratable Memory, MXDEV, MXLAB, PICMASTER, SEEVAL, SmartSensor and The Embedded Control Solutions Company are registered trademarks of Microchip Technology Incorporated in the U.S.A.

Analog-for-the-Digital Age, Application Maestro, dsPICDEM, dsPICDEM.net, dsPICworks, ECAN, ECONOMONITOR, FanSense, FlexROM, fuzzyLAB, In-Circuit Serial Programming, ICSP, ICEPIC, Linear Active Thermistor, MPASM, MPLIB, MPLINK, MPSIM, PCKIT, PICDEM, PICDEM.net, PICLAB, PICtail, PowerCal, PowerInfo, PowerMate, PowerTool, rLAB, rPICDEM, Select Mode, Smart Serial, SmartTel, Total Endurance and WiperLock are trademarks of Microchip Technology Incorporated in the U.S.A. and other countries.

SQTP is a service mark of Microchip Technology Incorporated in the U.S.A.

All other trademarks mentioned herein are property of their respective companies.

© 2005, Microchip Technology Incorporated, Printed in the U.S.A., All Rights Reserved.

 Printed on recycled paper.

**QUALITY MANAGEMENT SYSTEM
CERTIFIED BY DNV
== ISO/TS 16949:2002 ==**

Microchip received ISO/TS-16949:2002 quality system certification for its worldwide headquarters, design and wafer fabrication facilities in Chandler and Tempe, Arizona and Mountain View, California in October 2003. The Company's quality system processes and procedures are for its PICmicro® 8-bit MCUs, KEELOQ® code hopping devices, Serial EEPROMs, microperipherals, nonvolatile memory and analog products. In addition, Microchip's quality system for the design and manufacture of development systems is ISO 9001:2000 certified.



WORLDWIDE SALES AND SERVICE

AMERICAS

Corporate Office
2355 West Chandler Blvd.
Chandler, AZ 85224-6199
Tel: 480-792-7200
Fax: 480-792-7277
Technical Support:
<http://support.microchip.com>
Web Address:
www.microchip.com

Atlanta
Alpharetta, GA
Tel: 770-640-0034
Fax: 770-640-0307

Boston
Westborough, MA
Tel: 774-760-0087
Fax: 774-760-0088

Chicago
Itasca, IL
Tel: 630-285-0071
Fax: 630-285-0075

Dallas
Addison, TX
Tel: 972-818-7423
Fax: 972-818-2924

Detroit
Farmington Hills, MI
Tel: 248-538-2250
Fax: 248-538-2260

Kokomo
Kokomo, IN
Tel: 765-864-8360
Fax: 765-864-8387

Los Angeles
Mission Viejo, CA
Tel: 949-462-9523
Fax: 949-462-9608

San Jose
Mountain View, CA
Tel: 650-215-1444
Fax: 650-961-0286

Toronto
Mississauga, Ontario,
Canada
Tel: 905-673-0699
Fax: 905-673-6509

ASIA/PACIFIC

Australia - Sydney
Tel: 61-2-9868-6733
Fax: 61-2-9868-6755

China - Beijing
Tel: 86-10-8528-2100
Fax: 86-10-8528-2104

China - Chengdu
Tel: 86-28-8676-6200
Fax: 86-28-8676-6599

China - Fuzhou
Tel: 86-591-8750-3506
Fax: 86-591-8750-3521

China - Hong Kong SAR
Tel: 852-2401-1200
Fax: 852-2401-3431

China - Qingdao
Tel: 86-532-8502-7355
Fax: 86-532-8502-7205

China - Shanghai
Tel: 86-21-5407-5533
Fax: 86-21-5407-5066

China - Shenyang
Tel: 86-24-2334-2829
Fax: 86-24-2334-2393

China - Shenzhen
Tel: 86-755-8203-2660
Fax: 86-755-8203-1760

China - Shunde
Tel: 86-757-2839-5507
Fax: 86-757-2839-5571

China - Wuhan
Tel: 86-27-5980-5300
Fax: 86-27-5980-5118

China - Xian
Tel: 86-29-8833-7250
Fax: 86-29-8833-7256

ASIA/PACIFIC

India - Bangalore
Tel: 91-80-2229-0061
Fax: 91-80-2229-0062

India - New Delhi
Tel: 91-11-5160-8631
Fax: 91-11-5160-8632

India - Pune
Tel: 91-20-2566-1512
Fax: 91-20-2566-1513

Japan - Yokohama
Tel: 81-45-471-6166
Fax: 81-45-471-6122

Korea - Gumi
Tel: 82-54-473-4301
Fax: 82-54-473-4302

Korea - Seoul
Tel: 82-2-554-7200
Fax: 82-2-558-5932 or
82-2-558-5934

Malaysia - Penang
Tel: 60-4-646-8870
Fax: 60-4-646-5086

Philippines - Manila
Tel: 63-2-634-9065
Fax: 63-2-634-9069

Singapore
Tel: 65-6334-8870
Fax: 65-6334-8850

Taiwan - Hsin Chu
Tel: 886-3-572-9526
Fax: 886-3-572-6459

Taiwan - Kaohsiung
Tel: 886-7-536-4818
Fax: 886-7-536-4803

Taiwan - Taipei
Tel: 886-2-2500-6610
Fax: 886-2-2508-0102

Thailand - Bangkok
Tel: 66-2-694-1351
Fax: 66-2-694-1350

EUROPE

Austria - Wels
Tel: 43-7242-2244-399
Fax: 43-7242-2244-393

Denmark - Copenhagen
Tel: 45-4450-2828
Fax: 45-4485-2829

France - Paris
Tel: 33-1-69-53-63-20
Fax: 33-1-69-30-90-79

Germany - Munich
Tel: 49-89-627-144-0
Fax: 49-89-627-144-44

Italy - Milan
Tel: 39-0331-742611
Fax: 39-0331-466781

Netherlands - Drunen
Tel: 31-416-690399
Fax: 31-416-690340

Spain - Madrid
Tel: 34-91-708-08-90
Fax: 34-91-708-08-91

UK - Wokingham
Tel: 44-118-921-5869
Fax: 44-118-921-5820