

# TC3403

## +1.8V Low Power, Quad Input, 16-Bit Sigma-Delta A/D Converter with a Power Fault Monitor and Microprocessor Reset Circuit

### Features

- 16-bit Resolution at Eight Conversions Per Second, Adjustable Down to 10-bit Resolution at 512 Conversions Per Second
- 1.8V – 5.5V Operation, Low Power Operating 280 $\mu$ A; Sleep: 93 $\mu$ A
- Four Single-ended Inputs with Built-in Multiplexer
- microPort™ Serial Bus Requires only two Interface Lines
- Uses Internal or External Reference
- Automatically Enters Sleep Mode when not in use
- V<sub>DD</sub> Monitor and Reset Generator Operational in Shutdown Mode
- Early Warning Power Fail Detector, also suitable as Wake-Up Timer Operational in Shutdown Mode

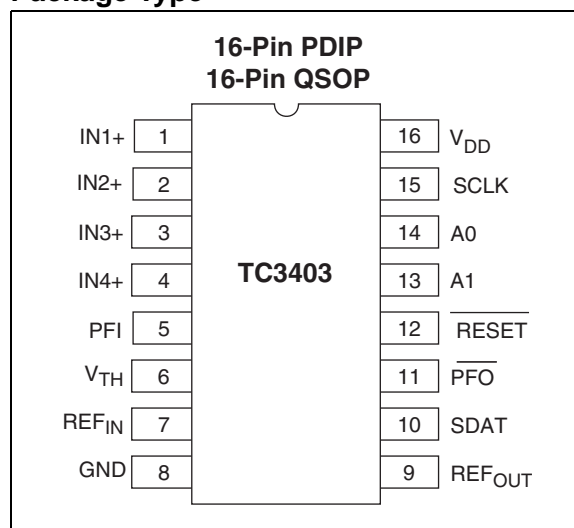
### Applications

- Consumer Electronics, Thermostats, CO Monitors, Humidity Meters, Security Sensors
- Embedded Systems, Data Loggers, Portable Equipment
- Medical Instruments

### Device Selection Table

Part Number	Package	Temperature Range
TC3403VPE	16-Pin PDIP (Narrow)	0°C to +85°C
TC3403VQR	16-Pin QSOP (Narrow)	0°C to +85°C

### Package Type



### General Description

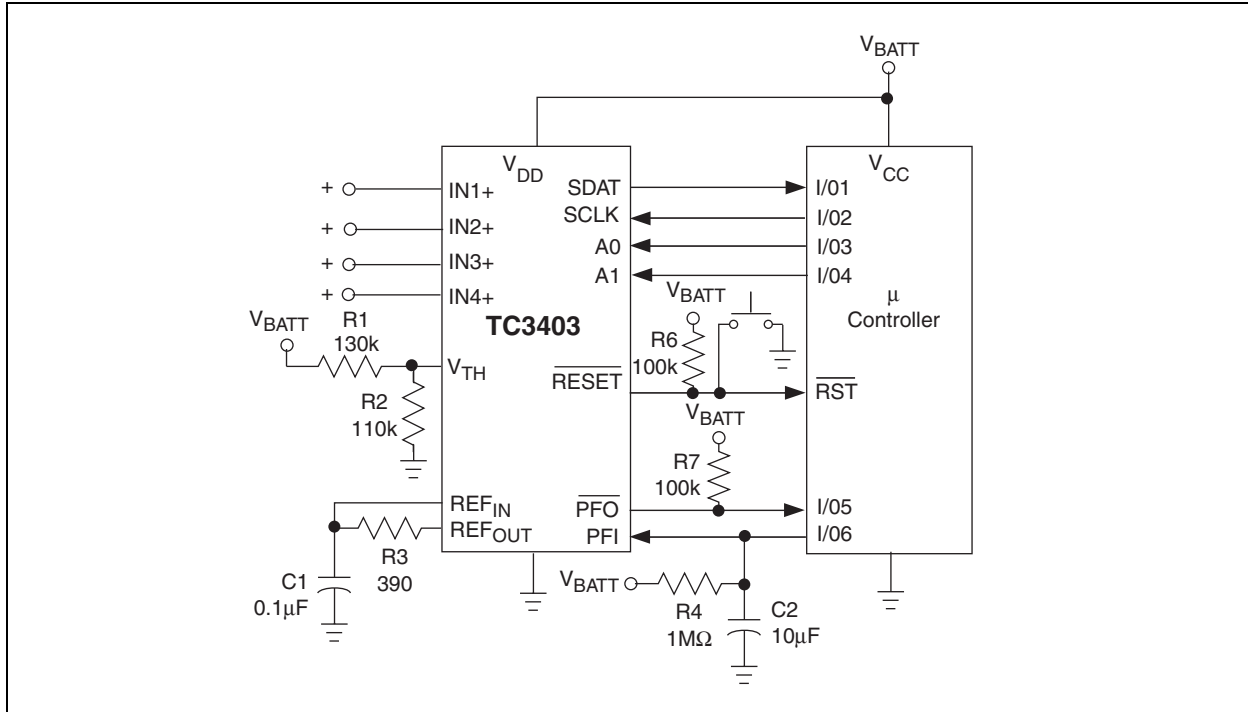
The TC3403 is a low cost, low power analog-to-digital converter based on Microchip's Sigma-Delta technology. It will perform 16-bit conversions (15-bit plus sign) at up to eight per second. The TC3403 is optimized for use as a microcontroller peripheral in low cost, battery operated systems. A voltage reference is included, or an external reference can be used. A V<sub>DD</sub> monitor with a reset generator provides Power-on Reset and Brown-out protection while an extra threshold detector is suitable for use as an early warning Power Fail detector, or as a Wake-up Timer.

The TC3403's 2-wire microPort™ digital interface is used for starting conversions and for reading out the data. Driving the SCLK line low starts a conversion. After the conversion starts, each additional falling edge (up to six) detected on SCLK for t<sub>4</sub> seconds reduces the A/D resolution by one bit and cuts conversion time in half. After a conversion is completed, clocking the SCLK line puts the MSB through LSB of the resulting data word onto the SDAT line, much like a shift register. The part automatically sleeps when not performing a data conversion.

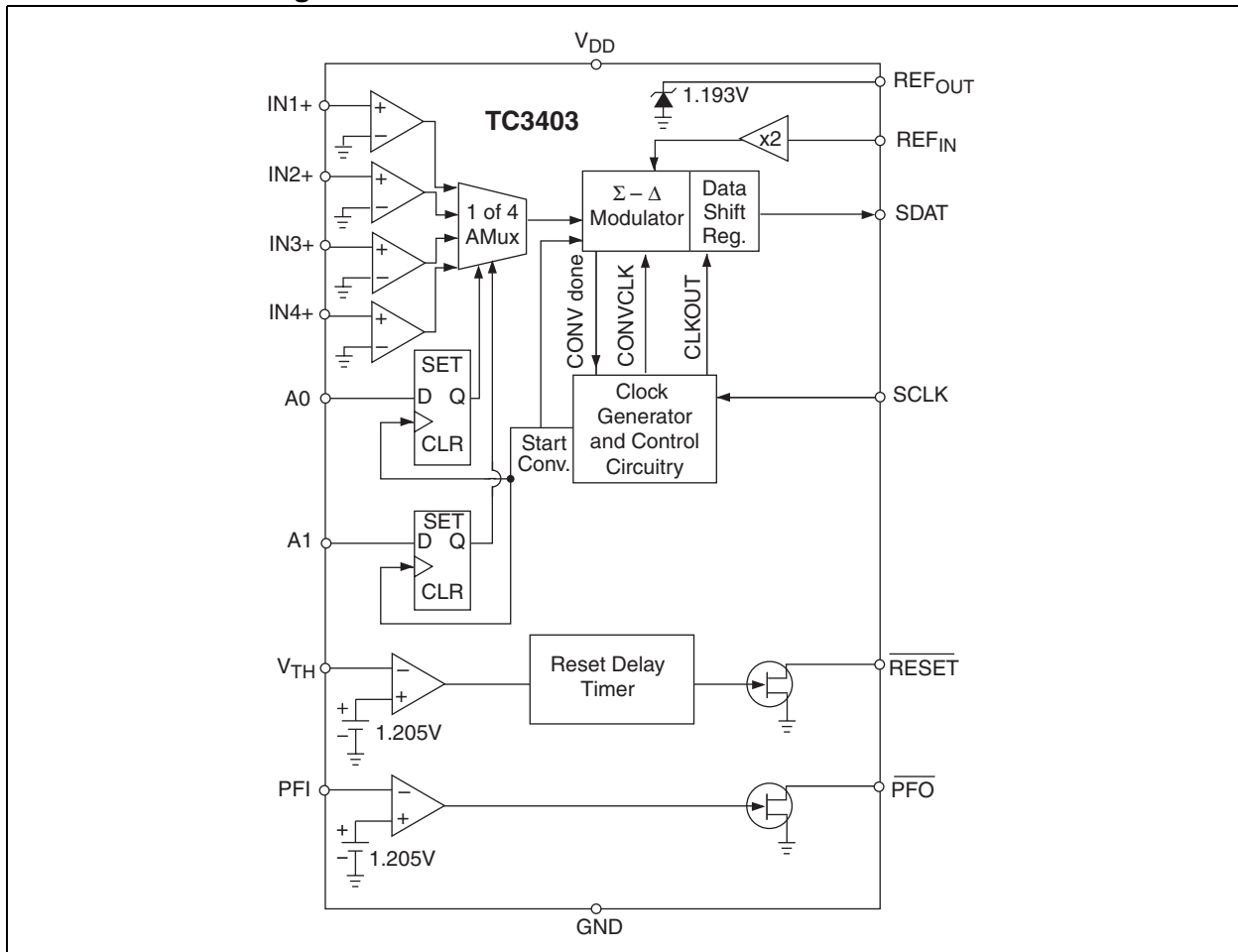
The TC3403 is available in a 16-Pin PDIP and a 16-Pin QSOP package.

# TC3403

## Typical Application



## Functional Block Diagram



## 1.0 ELECTRICAL CHARACTERISTICS

### Absolute Maximum Ratings\*

Supply Voltage .....	6.0V
Voltage on Pins:	
PFO, RESET .....	(GND – 0.3V) to 5.5V
Input Voltage (All Other Pins):	
.....	(GND – 0.3V) to (V <sub>DD</sub> + 0.3V)
Operating Temperature Range .....	0°C to 85°C
Storage Temperature .....	-65°C to +150°C

\*Stresses above those listed under "Absolute Maximum Ratings" may cause permanent damage to the device. These are stress ratings only and functional operation of the device at these or any other conditions above those indicated in the operation sections of the specifications is not implied. Exposure to Absolute Maximum Rating conditions for extended periods may affect device reliability.

### TC3403 DC ELECTRICAL SPECIFICATIONS

**Electrical Characteristics:** T<sub>A</sub> = 25°C and V<sub>DD</sub> = 2.7V, unless otherwise specified. **Boldface** type specifications apply for temperatures of 0°C to 85°C. V<sub>REF</sub> = 1.25V, Internal Clock Frequency = 520kHz.

Symbol	Parameter	Min	Typ	Max	Unit	Test Conditions
<b>Power Supply</b>						
V <sub>DD</sub>	Supply Voltage	1.8	—	5.5	V	
I <sub>DD</sub>	Supply Current, During Data Conversion	—	280	—	μA	
I <sub>DDSLLEEP</sub>	Supply Current, Sleep Mode	—	93	115	μA	T <sub>A</sub> = +25°C
		—	<b>106</b>	<b>120</b>	μA	
<b>Accuracy (Differential Inputs)</b>						
RES	Resolution	—	16	—	Bits	
INL	Integral Non-Linearity	—	.0038	—	%FSR	V <sub>DD</sub> = 2.7V
V <sub>OS</sub>	Offset Error	—	—	<b>±0.9</b>	%FSR	IN+, IN- = 0V
V <sub>NOISE</sub>	Referred to input	—	60	—	μVrms	
CMR	Common Mode Rejection	—	75	—	dB	At DC
FSE	Full Scale Error	—	0.4%	—	%FS	
PSRR	Power Supply Rejection Ratio	—	75	—	dB	V <sub>DD</sub> = 2.5V to 3.5V
<b>INn</b>						
V <sub>IN</sub>	Input Voltage	—	—	V <sub>DD</sub>	V	<b>Note 1</b>
	Absolute Voltage Range on INn	GND	—	V <sub>DD</sub>	V	
	Input Bias Current	—	1	100	nA	
C <sub>IN</sub>	Input Sampling Capacitance	—	2	—	pF	
R <sub>IN</sub>	Differential Input Resistance	—	2.0	—	MΩ	<b>Note 2</b>
<b>REF<sub>IN</sub>, REF<sub>OUT</sub></b>						
V <sub>REF</sub>	REF <sub>IN</sub> Voltage Range	0	—	1.25	V	
I <sub>REF</sub>	REF <sub>IN</sub> Input Current	—	1	—	μA	
V <sub>REFOUT</sub>	REF <sub>OUT</sub> Voltage	—	1.193	—	V	
REF <sub>SINK</sub>	REF <sub>OUT</sub> Current Sink Capability	—	10	—	μA	
REF <sub>SRC</sub>	REF <sub>OUT</sub> Current Source Capability	300	—	—	μA	

- Note** 1: Differential input voltage defined as (V<sub>IN+</sub> – V<sub>IN-</sub>).  
 2: Resistance from INn+ to INn- or INn to GND.  
 3: @ V<sub>DD</sub> = 1.8V, I<sub>SOURCE</sub> ≤ 200μA.

# TC3403

## TC3403 DC ELECTRICAL SPECIFICATIONS (CONTINUED)

**Electrical Characteristics:**  $T_A = 25^\circ\text{C}$  and  $V_{DD} = 2.7\text{V}$ , unless otherwise specified. **Boldface** type specifications apply for temperatures of  $0^\circ\text{C}$  to  $85^\circ\text{C}$ .  $V_{REF} = 1.25\text{V}$ , Internal Clock Frequency = 520kHz.

Symbol	Parameter	Min	Typ	Max	Unit	Test Conditions
<b>SCLK, A0, A1, ENABLE</b>						
$V_{IL}$	Input Low Voltage	—	—	<b><math>0.3 \times V_{DD}</math></b>	V	
$V_{IH}$	Input High Voltage	<b><math>0.7 \times V_{DD}</math></b>	—	—	V	
$I_{LEAK}$	Leakage Current	—	1	—	$\mu\text{A}$	
<b>SDAT, RESET, PFO</b>						
$V_{OL}$	Output Low Voltage	—	—	0.4	V	$I_{OL} = 1.5\text{mA}$
$V_{OH}$	Output High Voltage (SDAT)	$0.9 \times V_{DD}$	—	—	V	$I_{SOURCE} = 400\mu\text{A}$ ( <b>Note 3</b> )
$V_{DDMIN}$	Minimum $V_{DD}$ for PFO, RESET Valid	—	1.1	1.3	$\mu\text{A}$	
<b><math>V_{TH}</math>, PFI</b>						
$V_{CCPFI}$	PFI Input Voltage Range	0	—	$V_{DD}$	V	
	$V_{TH}$ , PFI Input Current	-0.1	.01	0.1	$\mu\text{A}$	
$V_{THR}$	Threshold ( $V_{TH}$ , PFI)	—	1.23	—	V	
	Threshold Hysteresis	—	30	—	mV	
	Threshold Tempco	—	30	—	ppm/ $^\circ\text{C}$	

- Note 1:** Differential input voltage defined as  $(V_{IN+} - V_{IN-})$ .  
**Note 2:** Resistance from  $INn+$  to  $INn-$  or  $INn$  to GND.  
**Note 3:** @  $V_{DD} = 1.8\text{V}$ ,  $I_{SOURCE} \leq 200\mu\text{A}$ .

## TC3403 AC ELECTRICAL SPECIFICATIONS

**Electrical Characteristics:**  $T_A = 25^\circ\text{C}$  and  $V_{DD} = 2.7\text{V}$ , unless otherwise specified. **Boldface** type specifications apply for temperatures of  $0^\circ\text{C}$  to  $85^\circ\text{C}$ .  $V_{REF} = 1.25\text{V}$ , Internal Clock Frequency = 520kHz.

Symbol	Parameter	Min	Typ	Max	Unit	Test Conditions
$t_1$	Resolution Reduction Clock Width	1	—	—	$\mu\text{sec}$	Width of SCLK (Negative)
$t_2$	Resolution Reduction Clock Width	1	—	—	$\mu\text{sec}$	Width of SCLK (Positive)
$t_3$	Conversion Time (15-bit Plus Sign)	—	125	—	msec	16-bit Conversion, $T_A = 25^\circ\text{C}$ ( <b>Note 1</b> )
	Conversion Time (14-bit Plus Sign)	—	$t_3/2.0$	—	msec	15-bit Conversion
	Conversion Time (13-bit Plus Sign)	—	$t_3/4.0$	—	msec	14-bit Conversion
	Conversion Time (12-bit Plus Sign)	—	$t_3/7.8$	—	msec	13-bit Conversion
	Conversion Time (11-bit Plus Sign)	—	$t_3/15.1$	—	msec	12-bit Conversion
	Conversion Time (10-bit Plus Sign)	—	$t_3/28.6$	—	msec	11-bit Conversion
	Conversion Time (9-bit Plus Sign)	—	$t_3/51.4$	—	msec	10-bit Conversion
$t_4$	Resolution Reduction Window	—	$t_3/85.7$	—	msec	Width of SCLK
$t_5$	SCLK to Data Valid	<b>1000</b>	—	—	nsec	SCLK Falling Edge to SDAT Valid
$t_6$	Address Setup	<b>0</b>	—	—	nsec	Address Valid to SCLK
$t_7$	Address Hold	<b>1000</b>	—	—	nsec	SCLK to Address Valid Hold
$t_8$	Acknowledge Delay	—	—	<b>1000</b>	nsec	SCLK to SDAT Delay
$t_9$	RESET Active Timeout Period	—	$t_3 \times 2$	—	msec	Delay from POR or Brown-out Recovery to RESET = $V_{OH}$
$t_{10}$	PFO Delay	—	25	—	$\mu\text{sec}$	PFI to PFO Delay
$t_{11}$	RESET Delay	5	—	<b>64</b>	$\mu\text{sec}$	Delay $V_{TH}$ Falling at 10V/msec to RESET Low

- Note 1:** Nominal temperature drift is -2830ppm/ $^\circ\text{C}$  for temperature less than  $25^\circ\text{C}$  and -1340ppm/ $^\circ\text{C}$  for temperatures greater than  $25^\circ\text{C}$ .

## 2.0 PIN DESCRIPTIONS

The descriptions of the pins are listed in Table 2-1.

**TABLE 2-1: PIN FUNCTION TABLE**

Pin No. (16-Pin PDIP) (16-Pin QSOP)	Symbol	Description
1	IN1+	Analog Input. This is the positive terminal of a true differential input with the negative input tied internally to GND. See Section 1.0, Electrical Characteristics.
2	IN2+	Analog Input. This is the positive terminal of a true differential input with the negative input tied internally to GND. See Section 1.0, Electrical Characteristics.
3	IN3+	Analog Input. This is the positive terminal of a true differential input with the negative input tied internally to GND. See Section 1.0, Electrical Characteristics.
4	IN4+	Analog Input. This is the positive terminal of a true differential input with the negative input tied internally to GND. See Section 1.0, Electrical Characteristics.
5	PFI	Analog Input. This is the positive input to an internal comparator used as a threshold detector. The negative input is tied to an internal reference.
6	V <sub>TH</sub>	Analog Input. This is the positive input to the internal comparator used to monitor the voltage supply. The negative input is tied to an internal reference. When V <sub>TH</sub> falls below the internal reference, the reset generator drives RESET low. See Section 1.0, Electrical Characteristics.
7	REF <sub>IN</sub>	Analog Input. The converter's reference voltage is the differential between this pin and ground times two. It may be tied directly to REF <sub>OUT</sub> or scaled using a resistor divider. Any user supplied reference voltage less than 1.25 may be used in place of REF <sub>OUT</sub> .
8	GND	Ground Terminal.
9	REF <sub>OUT</sub>	Analog Output. The internal reference connects to this pin. It may be scaled externally and tied to the REF <sub>IN</sub> input to provide the converter's reference voltage. Care must be taken in connecting external circuitry to this pin. This pin is in a high impedance state during Sleep mode.
10	SDAT	Digital Output (push-pull). This is the microPort™ serial data output. SDAT is driven low while the TC3403 is converting data, effectively providing a "busy" signal. After the conversion is complete, every high to low transition on the SCLK pin puts a bit from the resulting data word on the SDAT pin (from MSB to LSB).
11	PFO	Digital Output (open drain). This is the output of the internal threshold detector. When PFI is less than the internal reference, PFO is driven low.
12	RESET	Digital Output (open drain). This is the output of the V <sub>DD</sub> monitor reset generator. RESET is driven low when a Power-on Reset or Brown-out condition is detected. See Section 1.0, AC Electrical Characteristics.
13	A1	Digital Input. Controls analog multiplexer in conjunction with A0 to select one of the four Input channels. This address is latched at the falling edge of the SCLK, which starts an A/D conversion. A1, A0 = 00 = Input 1; 01 = Input 2; 10 = Input 3; 11 = Input 4.
14	A0	Digital Input. Controls analog multiplexer in conjunction with A1 to select one of four Input channels. This address is latched at the falling edge of the SCLK, which starts an A/D conversion. A1, A0 = 00 = Input 1; 01 = Input 2; 10 = Input 3; 11 = Input 4.
15	SCLK	Digital Input. This is the microPort™ serial clock input. The TC3403 comes out of Sleep mode and a conversion cycle begins when this pin is driven low. After the conversion starts, each additional falling edge (up to six) detected on SCLK for t <sub>4</sub> seconds reduces the A/D resolution by one bit. When the conversion is complete, the data word can be shifted out on the SDAT pin by clocking the SCLK pin.
16	V <sub>DD</sub>	Power Supply Input.

## 3.0 DETAILED DESCRIPTION

The TC3403 has a 16-bit sigma-delta A/D converter. It has two differential inputs, an analog multiplexer, a  $V_{DD}$  monitor with reset generator and an early warning Power Fail detector. See the Typical Application circuit and the Functional Block diagram. The key components of the TC3403 are described below.

Also refer to Figure 3-5, A/D Operational Flowchart and the Timing Diagrams, Figure 3-1, Figure 3-2 and Figure 3-3.

### 3.1 A/D Converter Operation

When the TC3403 is not converting, it is in Sleep mode with both the SCLK and SDAT lines high. An A/D conversion is initiated by a high to low transition on the SCLK line at which time the internal clock of the TC3403 is started and the address value (A0 and A1) is internally latched. The address value steers the analog multiplexer to select the input channel to be converted. Each additional high to low transition of SCLK (following the initial SCLK falling edge) during the time interval  $t_4$ , will decrement the conversion resolution by one bit and reduce the conversion time by one half. The time interval  $t_4$  is referred to as the resolution reduction window. The minimum conversion resolution is 10-bits so any more than 6 SCLK transitions during  $t_4$  will be ignored.

After each high to low transition of SCLK, in the  $t_4$  interval, the SDAT output is driven high by the TC3403 to acknowledge that the resolution has been decremented. When the SCLK returns high or the  $t_4$  interval ends, the SDAT line returns low (see Figure 3-2). When the conversion is complete SDAT is driven high. The TC3403 now enters Sleep mode and the conversion value can be read as a serial data word on the SDAT line.

### 3.2 Reading the Data Word

After the conversion is complete and SDAT goes high, the conversion value can be clocked serially onto the SDAT line by high to low transitions of the SCLK. The data word is in two's complement format with the sign bit clocked onto the SDAT line, first followed by the MSB and ending in the LSB. For a 16-bit conversion the data word would consist of a sign bit followed by 15 magnitude bits, Table 3-1 shows the data word versus input voltage for a 16-bit conversion. Note that the full scale input voltage range is  $\pm(2 \text{ REF}_{IN} - 1\text{LSB})$ . When  $\text{REF}_{OUT}$  is fed back directly to  $\text{REF}_{IN}$ , an LSB is  $73\mu\text{V}$  for a 16-bit conversion, as  $\text{REF}_{OUT}$  is typically 1.193V.

Figure 3-4 shows typical SCLK and SDAT waveforms for 16, 12 and 10-bit conversions. Note that any complete convert and read cycle requires 17 negative edge clock pulses. The first is the convert command. Then, up to six of these can occur in the resolution reduction window,  $t_4$ , to decrement resolution. The remaining pulses clock out the conversion data word.

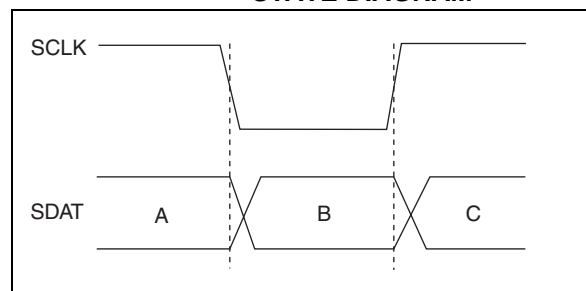
**TABLE 3-1: DATA CONVERSION WORD VS. VOLTAGE INPUT ( $\text{REF}_{IN} = 1.193\text{V}$ )**

Data Word	INn+ – INn- (Volts)
0111 1111 1111 1111	2.38596 (Positive Full Scale)
0000 0000 0000 0001	72.8 E -6
0000 0000 0000 0000	0
1111 1111 1111 1111	-72.8 E -6
1000 0000 0000 0001	-2.38596 (Negative Full Scale)
1000 0000 0000 0000	Reserved Code

The SCLK input has a filter which rejects any positive or negative pulse of width less than 50nsec to reduce noise. The rejection width of this pulse can vary between 50nsec and 750nsec depending on processing parameters and supply voltage.

Figure 3-1 and Table 3-2 show information for determining the mode of operation for the TC3403 by recording the value of SDAT for SCLK in a high, then low, then high state. For example, if SCLK goes through a 1-0-1 transition and the corresponding values of SDAT are 1-1-0, then the SCLK falling edge started a new data conversion. A 0-1-0 for SDAT would have indicated a resolution reduction had occurred. This is useful if the microcontroller has a Watchdog Reset or otherwise loses track of where the TC3403 is in the conversion and data readout sequence. The microcontroller can simply transition SCLK until it "finds" a Start Conversion condition.

**FIGURE 3-1: SCLK, SDAT LOGIC STATE DIAGRAM**

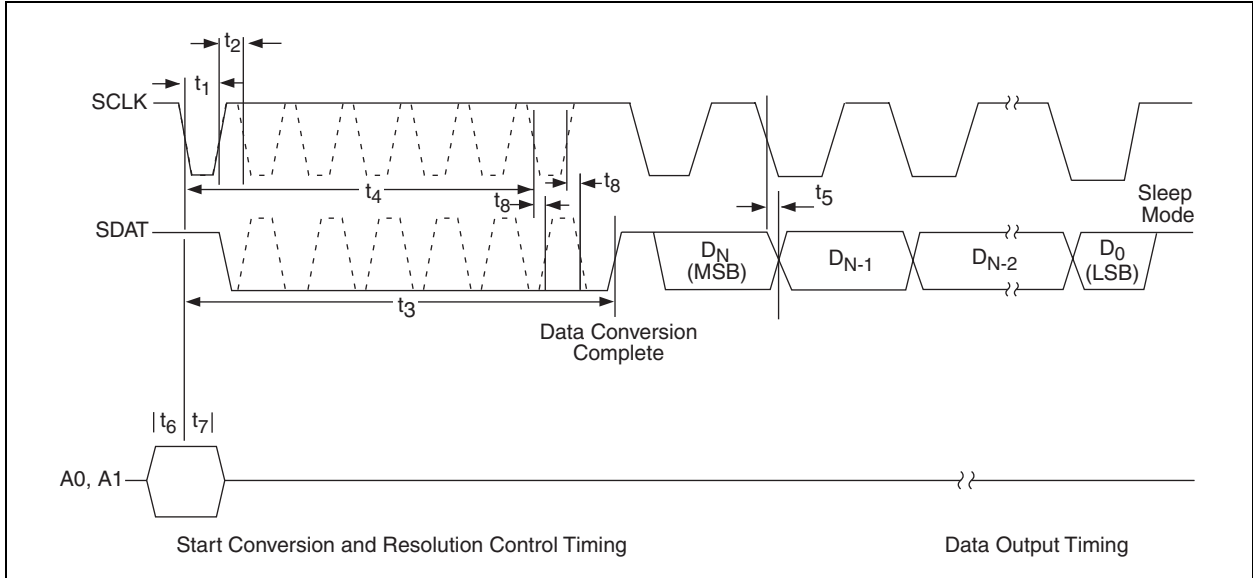


**TABLE 3-2: SCLK, SDAT LOGIC STATE**

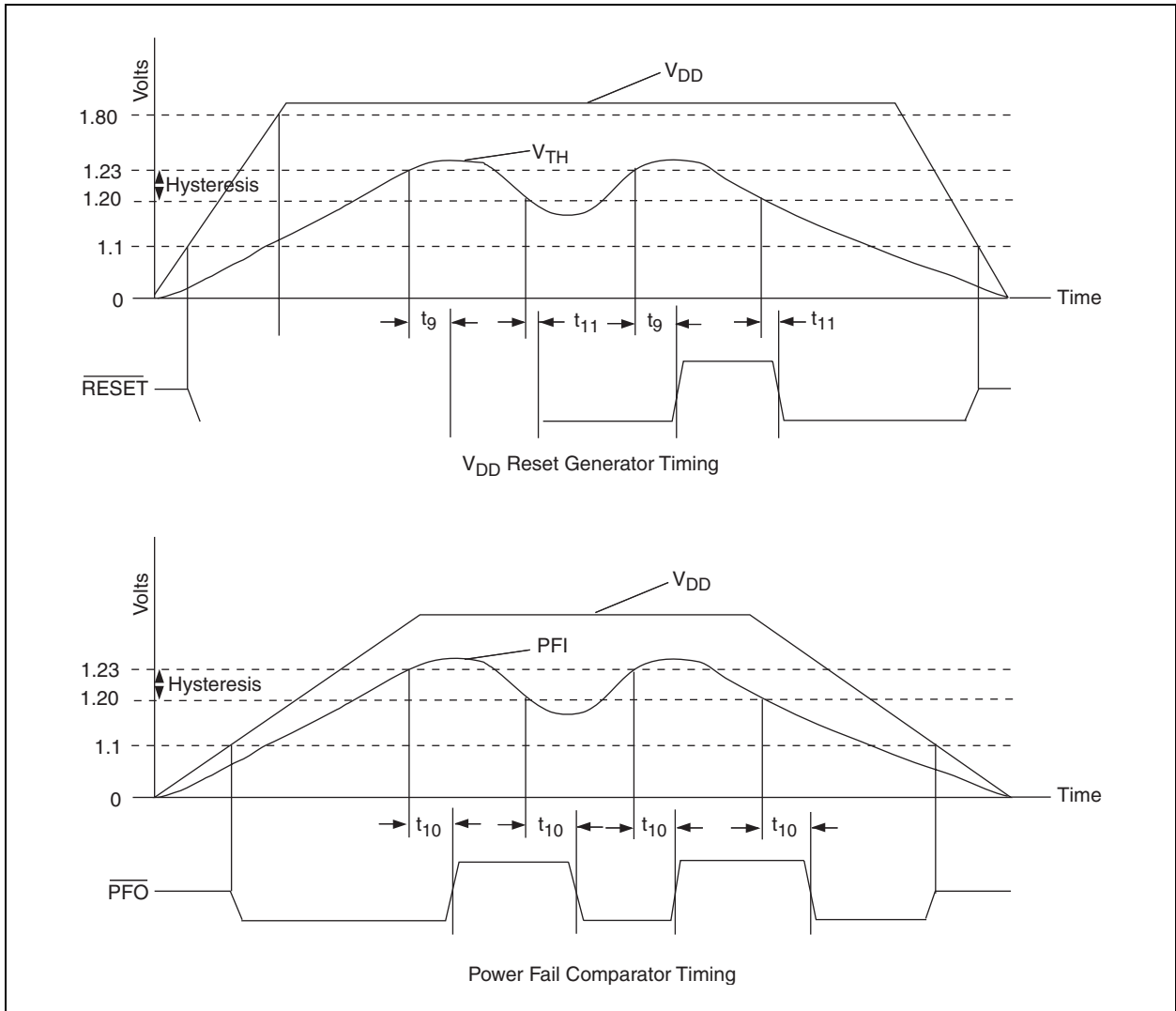
A	B	C	Status
1	1	0	Start Conversion
0	1	0	Resolution Reduction
x	1	1	Data Transfer
x	0	0	Data Transfer or Busy*

**\*Note:** The code X00 has a dual meaning: Data Transfer or Busy converting. To avoid confusion, the user should send only the required number of pulses for the desired resolution, then wait for SDAT to rise to 1, indicating conversion is complete before clocking SCLK again to read out data bits.

**FIGURE 3-2: CONVERSION AND DATA OUTPUT TIMING**

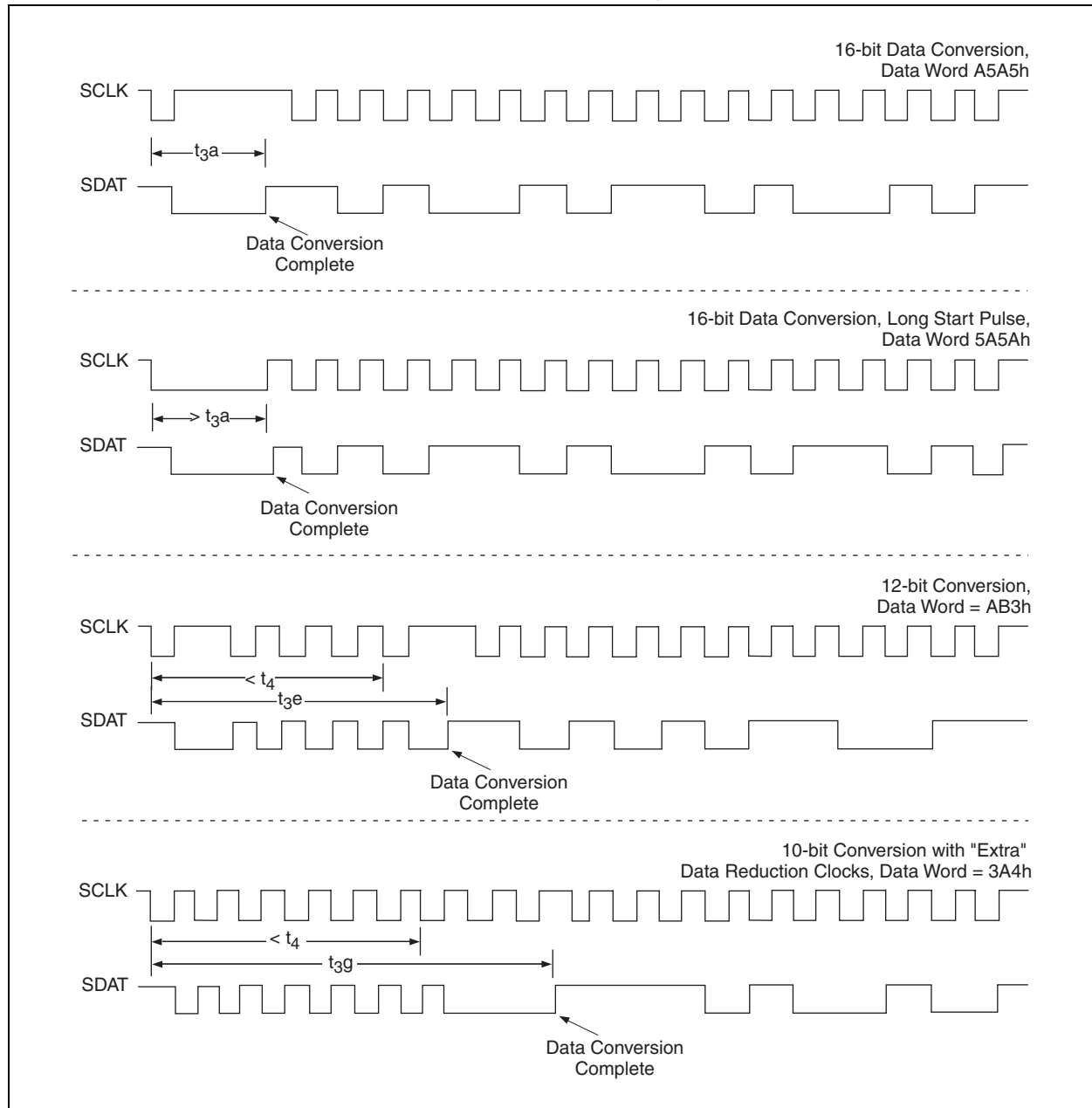


**FIGURE 3-3: RESET AND POWER FAIL TIMING**

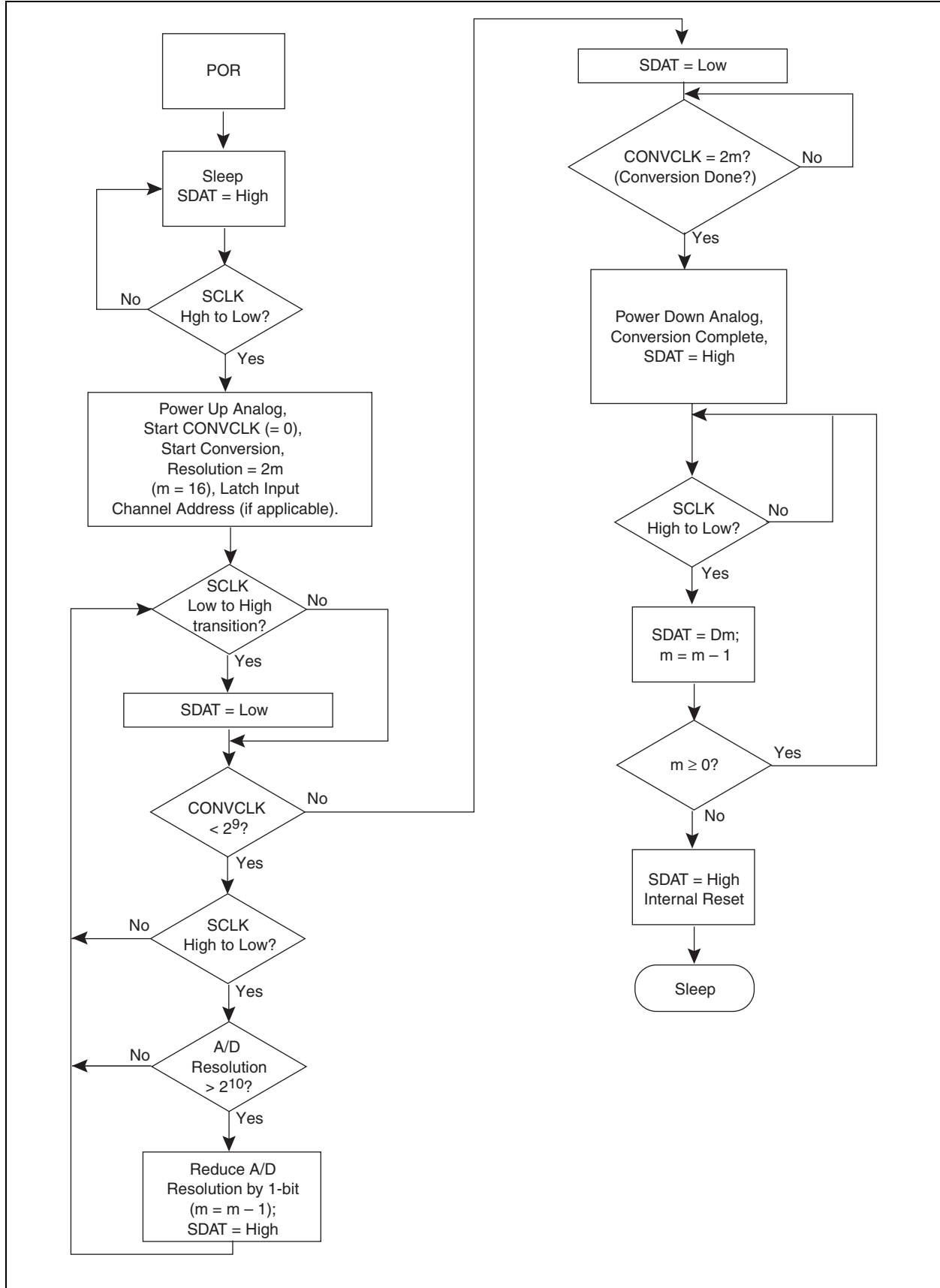


# TC3403

**FIGURE 3-4: SCLK AND SDAT WAVEFORMS FOR 16, 12 AND 10-BIT CONVERSIONS**



**FIGURE 3-5: A/D OPERATIONAL FLOWCHART**



## 3.3 $V_{DD}$ Monitor

The TC3403  $\overline{\text{RESET}}$  output is high impedance provided the voltage at  $V_{TH}$  is greater than the internal voltage reference. This reference is approximately the same value as the voltage appearing at  $\text{REF}_{OUT}$ . When  $V_{TH}$  is less than the internal reference,  $\overline{\text{RESET}}$  is pulled low. When  $V_{TH}$  rises above the internal reference voltage again,  $\overline{\text{RESET}}$  is held low for the reset active timeout period,  $t_9$ , before being released. The  $\overline{\text{RESET}}$  output is ensured to be valid for  $V_{DD} = 1.3\text{V}$  to  $5.5\text{V}$ .

When used to generate a Power-on or Brown-out Reset, an external resistor network is required to divide the appropriate  $V_{DD}$  threshold down to  $1.23\text{V}$  at the  $V_{TH}$  input, (See the Typical Application circuit). For example, to generate a POR for a  $V_{DD}$  at  $3\text{V} - 10\%$ , then the values of  $R1$  and  $R2$  should be  $137\text{k}\Omega$  and  $115\text{k}\Omega$  respectively.

Since  $\overline{\text{RESET}}$  is an open drain, it can be wired-OR'ed with another open drain or external switch if desired.

## 3.4 Power Fail Detector

The Power Fail detector is a comparator in which the inverting input is connected to the internal voltage reference. The non-inverting input is the PFI pin of the TC3403 and the  $\overline{\text{PFO}}$  pin is the active low, open drain output. This comparator is suitable as an early warning fail or low battery indicator. In a typical application, where a voltage regulator is being used to supply power to a system, the Power Fail comparator would monitor the input voltage to the regulator while the  $V_{DD}$  monitor would measure the output voltage of the regulator. Both  $\overline{\text{PFO}}$  and  $\overline{\text{RESET}}$  would drive interrupt pins of a microcontroller.

The Power Fail detector may be used as a Wake-up or Watchdog Timer. The Typical Application circuit shows an RC network on PFI with the capacitor tied to a tristated  $\mu\text{C}$  I/O pin. If  $R4$  is  $1\text{M}\Omega$  and  $C2$  is  $10\mu\text{F}$ , the time constant is roughly ten seconds. The  $\mu\text{C}$  resets the RC network by driving the I/O tied to PFI low and then tristating it. The RC network will ramp to  $1.23\text{V}$  in roughly 9 seconds, assuming a  $V_{BATT}$  of  $3.0\text{V}$ . With  $\overline{\text{PFO}}$  tied to a  $\mu\text{C}$  input or interrupt, the  $\mu\text{C}$  will see a low to high transition on  $\overline{\text{PFO}}$  when the voltage on PFI exceeds  $1.23\text{V}$ . The  $\overline{\text{PFO}}$  output is specified to be valid for  $V_{DD} = 1.3$  to  $5.5\text{V}$ .

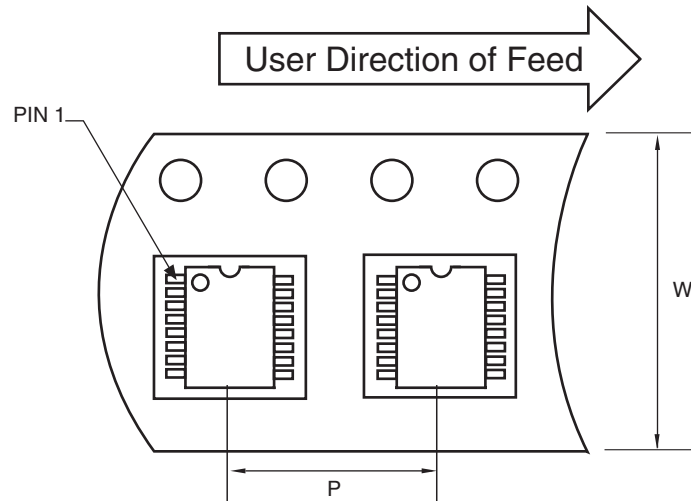
## 4.0 PACKAGING INFORMATION

### 4.1 Package Marking Information

Package marking data not available at this time.

### 4.2 Taping Forms

#### Component Taping Orientation for 16-Pin QSOP (Narrow) Devices



Standard Reel Component Orientation  
for TR Suffix Device

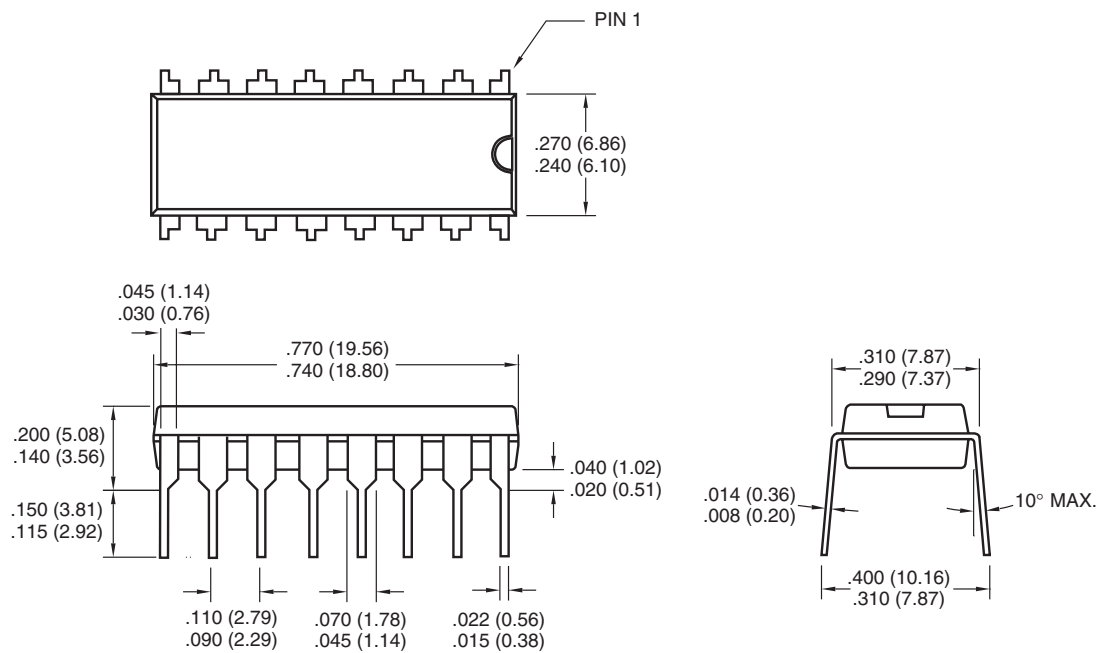
#### Carrier Tape, Reel Size, Number of Components Per Reel and Reel Size

Package	Carrier Width (W)	Pitch (P)	Part Per Full Reel	Reel Size
16-Pin QSOP (N)	12 mm	8 mm	2500	13 in

# TC3403

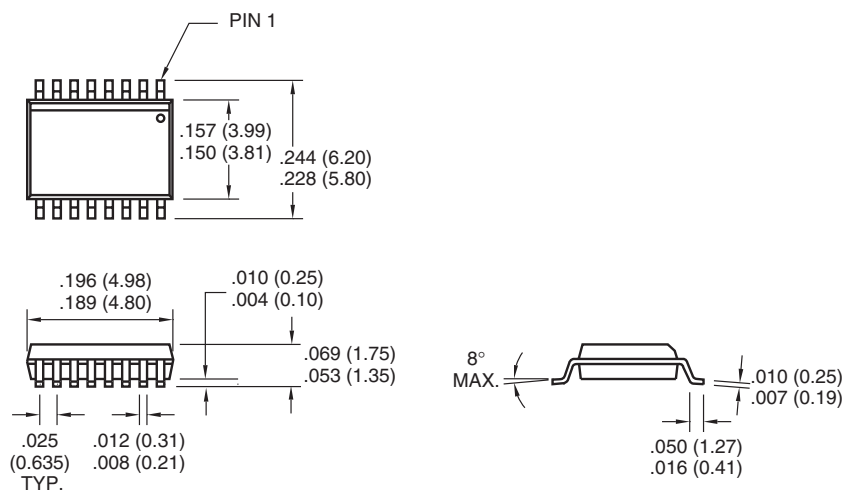
## 4.3 Package Dimensions

### 16-Pin PDIP (Narrow)



Dimensions: inches (mm)

### 16-Pin QSOP (Narrow)



Dimensions: inches (mm)

## SALES AND SUPPORT

### **Data Sheets**

Products supported by a preliminary Data Sheet may have an errata sheet describing minor operational differences and recommended workarounds. To determine if an errata sheet exists for a particular device, please contact one of the following:

1. Your local Microchip sales office
2. The Microchip Corporate Literature Center U.S. FAX: (480) 792-7277
3. The Microchip Worldwide Site ([www.microchip.com](http://www.microchip.com))

Please specify which device, revision of silicon and Data Sheet (include Literature #) you are using.

### **New Customer Notification System**

Register on our web site ([www.microchip.com/cn](http://www.microchip.com/cn)) to receive the most current information on our products.

# TC3403

---

NOTES:

---

---

**Note the following details of the code protection feature on Microchip devices:**

- Microchip products meet the specification contained in their particular Microchip Data Sheet.
- Microchip believes that its family of products is one of the most secure families of its kind on the market today, when used in the intended manner and under normal conditions.
- There are dishonest and possibly illegal methods used to breach the code protection feature. All of these methods, to our knowledge, require using the Microchip products in a manner outside the operating specifications contained in Microchip's Data Sheets. Most likely, the person doing so is engaged in theft of intellectual property.
- Microchip is willing to work with the customer who is concerned about the integrity of their code.
- Neither Microchip nor any other semiconductor manufacturer can guarantee the security of their code. Code protection does not mean that we are guaranteeing the product as "unbreakable."

Code protection is constantly evolving. We at Microchip are committed to continuously improving the code protection features of our products. Attempts to break Microchip's code protection feature may be a violation of the Digital Millennium Copyright Act. If such acts allow unauthorized access to your software or other copyrighted work, you may have a right to sue for relief under that Act.

---

Information contained in this publication regarding device applications and the like is provided only for your convenience and may be superseded by updates. It is your responsibility to ensure that your application meets with your specifications. MICROCHIP MAKES NO REPRESENTATIONS OR WARRANTIES OF ANY KIND WHETHER EXPRESS OR IMPLIED, WRITTEN OR ORAL, STATUTORY OR OTHERWISE, RELATED TO THE INFORMATION, INCLUDING BUT NOT LIMITED TO ITS CONDITION, QUALITY, PERFORMANCE, MERCHANTABILITY OR FITNESS FOR PURPOSE. Microchip disclaims all liability arising from this information and its use. Use of Microchip's products as critical components in life support systems is not authorized except with express written approval by Microchip. No licenses are conveyed, implicitly or otherwise, under any Microchip intellectual property rights.

**Trademarks**

The Microchip name and logo, the Microchip logo, Accuron, dsPIC, KEELoQ, microID, MPLAB, PIC, PICmicro, PICSTART, PRO MATE, PowerSmart, rPIC, and SmartShunt are registered trademarks of Microchip Technology Incorporated in the U.S.A. and other countries.


AmpLab, FilterLab, Migratable Memory, MXDEV, MXLAB, PICMASTER, SEEVAL, SmartSensor and The Embedded Control Solutions Company are registered trademarks of Microchip Technology Incorporated in the U.S.A.

Analog-for-the-Digital Age, Application Maestro, dsPICDEM, dsPICDEM.net, dsPICworks, ECAN, ECONOMONITOR, FanSense, FlexROM, fuzzyLAB, In-Circuit Serial Programming, ICSP, ICEPIC, Linear Active Thermistor, MPASM, MPLIB, MPLINK, MPSIM, PCKIT, PICDEM, PICDEM.net, PICLAB, PICtail, PowerCal, PowerInfo, PowerMate, PowerTool, rLAB, rPICDEM, Select Mode, Smart Serial, SmartTel, Total Endurance and WiperLock are trademarks of Microchip Technology Incorporated in the U.S.A. and other countries.

SQTP is a service mark of Microchip Technology Incorporated in the U.S.A.

All other trademarks mentioned herein are property of their respective companies.

© 2005, Microchip Technology Incorporated, Printed in the U.S.A., All Rights Reserved.

 Printed on recycled paper.

**QUALITY MANAGEMENT SYSTEM  
CERTIFIED BY DNV  
== ISO/TS 16949:2002 ==**

*Microchip received ISO/TS-16949:2002 quality system certification for its worldwide headquarters, design and wafer fabrication facilities in Chandler and Tempe, Arizona and Mountain View, California in October 2003. The Company's quality system processes and procedures are for its PICmicro® 8-bit MCUs, KEELoQ® code hopping devices, Serial EEPROMs, microperipherals, nonvolatile memory and analog products. In addition, Microchip's quality system for the design and manufacture of development systems is ISO 9001:2000 certified.*



---

---

## WORLDWIDE SALES AND SERVICE

---

---

### AMERICAS

**Corporate Office**  
2355 West Chandler Blvd.  
Chandler, AZ 85224-6199  
Tel: 480-792-7200  
Fax: 480-792-7277  
Technical Support:  
<http://support.microchip.com>  
Web Address:  
[www.microchip.com](http://www.microchip.com)

**Atlanta**  
Alpharetta, GA  
Tel: 770-640-0034  
Fax: 770-640-0307

**Boston**  
Westborough, MA  
Tel: 774-760-0087  
Fax: 774-760-0088

**Chicago**  
Itasca, IL  
Tel: 630-285-0071  
Fax: 630-285-0075

**Dallas**  
Addison, TX  
Tel: 972-818-7423  
Fax: 972-818-2924

**Detroit**  
Farmington Hills, MI  
Tel: 248-538-2250  
Fax: 248-538-2260

**Kokomo**  
Kokomo, IN  
Tel: 765-864-8360  
Fax: 765-864-8387

**Los Angeles**  
Mission Viejo, CA  
Tel: 949-462-9523  
Fax: 949-462-9608

**San Jose**  
Mountain View, CA  
Tel: 650-215-1444  
Fax: 650-961-0286

**Toronto**  
Mississauga, Ontario,  
Canada  
Tel: 905-673-0699  
Fax: 905-673-6509

### ASIA/PACIFIC

**Australia - Sydney**  
Tel: 61-2-9868-6733  
Fax: 61-2-9868-6755

**China - Beijing**  
Tel: 86-10-8528-2100  
Fax: 86-10-8528-2104

**China - Chengdu**  
Tel: 86-28-8676-6200  
Fax: 86-28-8676-6599

**China - Fuzhou**  
Tel: 86-591-8750-3506  
Fax: 86-591-8750-3521

**China - Hong Kong SAR**  
Tel: 852-2401-1200  
Fax: 852-2401-3431

**China - Qingdao**  
Tel: 86-532-8502-7355  
Fax: 86-532-8502-7205

**China - Shanghai**  
Tel: 86-21-5407-5533  
Fax: 86-21-5407-5066

**China - Shenyang**  
Tel: 86-24-2334-2829  
Fax: 86-24-2334-2393

**China - Shenzhen**  
Tel: 86-755-8203-2660  
Fax: 86-755-8203-1760

**China - Shunde**  
Tel: 86-757-2839-5507  
Fax: 86-757-2839-5571

**China - Wuhan**  
Tel: 86-27-5980-5300  
Fax: 86-27-5980-5118

**China - Xian**  
Tel: 86-29-8833-7250  
Fax: 86-29-8833-7256

### ASIA/PACIFIC

**India - Bangalore**  
Tel: 91-80-2229-0061  
Fax: 91-80-2229-0062

**India - New Delhi**  
Tel: 91-11-5160-8631  
Fax: 91-11-5160-8632

**India - Pune**  
Tel: 91-20-2566-1512  
Fax: 91-20-2566-1513

**Japan - Yokohama**  
Tel: 81-45-471-6166  
Fax: 81-45-471-6122

**Korea - Gumi**  
Tel: 82-54-473-4301  
Fax: 82-54-473-4302

**Korea - Seoul**  
Tel: 82-2-554-7200  
Fax: 82-2-558-5932 or  
82-2-558-5934

**Malaysia - Penang**  
Tel: 60-4-646-8870  
Fax: 60-4-646-5086

**Philippines - Manila**  
Tel: 63-2-634-9065  
Fax: 63-2-634-9069

**Singapore**  
Tel: 65-6334-8870  
Fax: 65-6334-8850

**Taiwan - Hsin Chu**  
Tel: 886-3-572-9526  
Fax: 886-3-572-6459

**Taiwan - Kaohsiung**  
Tel: 886-7-536-4818  
Fax: 886-7-536-4803

**Taiwan - Taipei**  
Tel: 886-2-2500-6610  
Fax: 886-2-2508-0102

**Thailand - Bangkok**  
Tel: 66-2-694-1351  
Fax: 66-2-694-1350

### EUROPE

**Austria - Wels**  
Tel: 43-7242-2244-399  
Fax: 43-7242-2244-393

**Denmark - Copenhagen**  
Tel: 45-4450-2828  
Fax: 45-4485-2829

**France - Paris**  
Tel: 33-1-69-53-63-20  
Fax: 33-1-69-30-90-79

**Germany - Munich**  
Tel: 49-89-627-144-0  
Fax: 49-89-627-144-44

**Italy - Milan**  
Tel: 39-0331-742611  
Fax: 39-0331-466781

**Netherlands - Drunen**  
Tel: 31-416-690399  
Fax: 31-416-690340

**Spain - Madrid**  
Tel: 34-91-708-08-90  
Fax: 34-91-708-08-91

**UK - Wokingham**  
Tel: 44-118-921-5869  
Fax: 44-118-921-5820