

TC1682/TC1683/TC1684

Inverting Charge Pump Voltage Doublers with Active High Shutdown

Features

- Small 8-Pin MSOP Package
- Operates from 1.8V to 5.5V
- 120 Ohms (typ) Output Resistance
- 99% Voltage Conversion Efficiency
- Only 3 External Capacitors Required
- Power-Saving Shutdown Mode
- Low Active Supply Current
 - 95µA (typ) for TC1682
 - 225µA (typ) for TC1683
 - 700µA (typ) for TC1684
- Fully Compatible with 1.8V Logic Systems

Applications

- LCD Panel Bias
- Cellular Phones PA Bias
- Pagers
- PDAs, Portable Data Loggers
- Battery-Powered Devices

Device Selection Table

Part Number	Package	Osc. Freq. (kHz)	Operating Temp. Range
TC1682EUA	8-Pin MSOP	12	-40°C to +85°C
TC1683EUA	8-Pin MSOP	35	-40°C to +85°C
TC1684EUA	8-Pin MSOP	125	-40°C to +85°C

Package Type

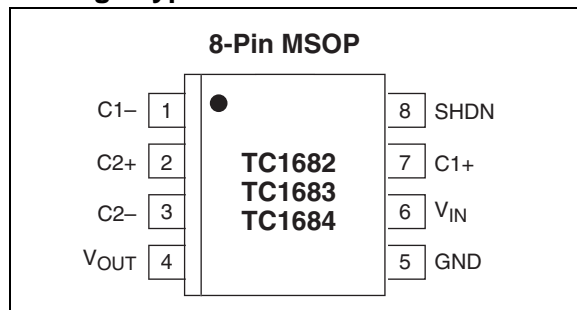

General Description

The TC1682/TC1683/TC1684 are CMOS charge pump converters that provide an inverted doubled output from a single positive supply. An on-board oscillator provides the clock and only three external capacitors are required for full circuit implementation. Switching frequencies are 12kHz for the TC1682, 35kHz for the TC1683, and 125kHz for the TC1684. When the SHDN pin is held at a logic high, the device goes into a very low power mode of operation consuming less than 1µA (typ) of supply current.

Low output source impedance (typically 120Ω), provides output current up to 10mA. The TC1682/TC1683/TC1684 feature a 1.8V to 5.5V operating voltage range and high efficiency, which make them an ideal choice for a wide variety of applications requiring a negative doubled voltage derived from a single positive supply (for example: generation of -7.2V from a +3.6V lithium cell or -10V generated from a +5V logic supply).

The minimum external part count, small physical size and shutdown mode feature make this family of products useful for a wide variety of negative bias power supply applications.

Functional Block Diagram

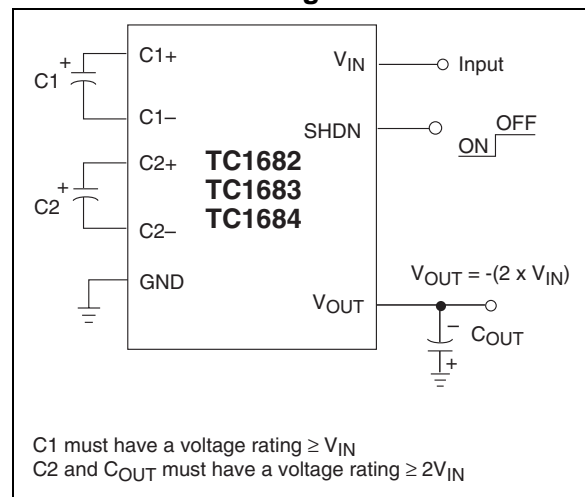

TC1682/TC1683/TC1684

1.0 ELECTRICAL CHARACTERISTICS

Absolute Maximum Ratings*

Input Voltage (V_{IN} to GND)..... +6.0V, -0.3V
 Output Voltage (V_{OUT} to GND)..... -12.0V, +0.3V
 Current at V_{OUT} Pin.....20mA
 Short-Circuit Duration V_{OUT} to GNDIndefinite
 Power Dissipation ($T_A \leq 70^\circ\text{C}$)
 8-Pin MSOP320mW
 Operating Temperature Range..... -40°C to +85°C
 Storage Temperature (Unbiased) -65°C to +150°C

*Stresses above those listed under "Absolute Maximum Ratings" may cause permanent damage to the device. These are stress ratings only and functional operation of the device at these or any other conditions above those indicated in the operation sections of the specifications is not implied. Exposure to Absolute Maximum Rating conditions for extended periods may affect device reliability.

TC1682/TC1683/TC1684 ELECTRICAL SPECIFICATIONS

Electrical Characteristics: $T_A = -40^\circ\text{C}$ to $+85^\circ\text{C}$, $V_{IN} = +5\text{V}$, $C1 = C2 = 3.3\mu\text{F}$ (TC1682), $C1 = C2 = 1\mu\text{F}$ (TC1683), $C1 = C2 = 0.33\mu\text{F}$ (TC1684), SHDN = GND, Typical values are at $T_A = +25^\circ\text{C}$							
Symbol	Parameter	Min	Typ	Max	Units	Device	Test Conditions
I_{DD}	Supply Current	—	95	160	μA	TC1682	
		—	225	480			
		—	700	1500			
I_{SHDN}	Shutdown Supply Current	—	0.5	2	μA	All	SHDN = $V_{IN} = +5\text{V}$
V_{MIN}	Minimum Supply Voltage	1.8	—	—	V	All	$R_{LOAD} = 1\text{k}\Omega$
V_{MAX}	Maximum Supply Voltage	—	—	5.5	V	All	$R_{LOAD} = 1\text{k}\Omega$
F_{OSC}	Oscillator Frequency	8.4	12	15.6	kHz	TC1682	
		24.5	35	45.5			
		65	125	170			
V_{IH}	SHDN Input Logic High	1.4	—	—	V	All	$V_{IN} = V_{MIN}$ to V_{MAX}
V_{IL}	SHDN Input Logic Low	—	—	0.4	V	All	$V_{IN} = V_{MIN}$ to V_{MAX}
V_{EFF}	Voltage Conversion Efficiency	95	99	—	%	All	$R_{LOAD} = \infty$
R_{OUT}	Output Resistance	—	120	170	Ω	All	$I_{LOAD} = 0.5\text{mA}$ to 10mA (Note 1)
T_{WK}	Wake-up Time From Shutdown Mode	—	1800	—	μsec	TC1682	$R_{LOAD} = 2\text{k}\Omega$
		—	600	—			
		—	200	—			

Note 1: Capacitor contribution is approximately 20% of the output impedance ($ESR = 1/\text{pump frequency} \times \text{capacitance}$).

2.0 PIN DESCRIPTIONS

The descriptions of the pins are listed in Table 2-1.

TABLE 2-1: PIN FUNCTION TABLE

Pin No. (8-Pin MSOP)	Symbol	Description
1	C1-	C1 commutation capacitor negative terminal.
2	C2+	C2 commutation capacitor positive terminal.
3	C2-	C2 commutation capacitor negative terminal.
4	V _{OUT}	Doubling inverting charge pump output ($-2 \times V_{IN}$).
5	GND	Ground.
6	V _{IN}	Positive power supply input.
7	C1+	C1 commutation capacitor positive terminal.
8	SHDN	Shutdown input (active high).

TC1682/TC1683/TC1684

3.0 DETAILED DESCRIPTION

The TC1682/TC1683/TC1684 inverting charge pump converters perform a $-2\times$ multiplication of the voltage applied to the V_{IN} pin. Conversion is performed using two *synchronous* switching matrices and three external capacitors. When the shutdown input is held at a logic high, the device goes into a very low power mode of operation consuming less than $1\mu\text{A}$ of supply current.

Figure 3-1 is a block diagram representation of the TC1682/TC1683/TC1684 architecture. The first switching stage inverts the voltage present at V_{IN} and the second stage uses the ' $-V_{IN}$ ' output generated from the first stage to produce the ' $-2\times$ ' output function from the second stage switching matrix.

Each device contains an on-board oscillator that synchronously controls the operation of the charge pump switching matrices. The TC1682 synchronously switches at 12kHz, the TC1683 synchronously switches at 35kHz, and the TC1684 synchronously switches at 125kHz. The different oscillator frequencies for this device family allow the user to trade-off capacitor size versus supply current. Faster oscillators can use smaller external capacitors, but will consume more supply current (see Section 1.0 Electrical Characteristics).

When the shutdown input is in a high state, the oscillator and both switch matrices are powered off placing the TC1682/TC1683/TC1684 in the shutdown mode. When the V_{IN} supply input is powered from an external battery, the shutdown mode minimizes power consumption, which in turn will extend the life of the battery.

FIGURE 3-1: TC1682/TC1683/TC1684 ARCHITECTURE

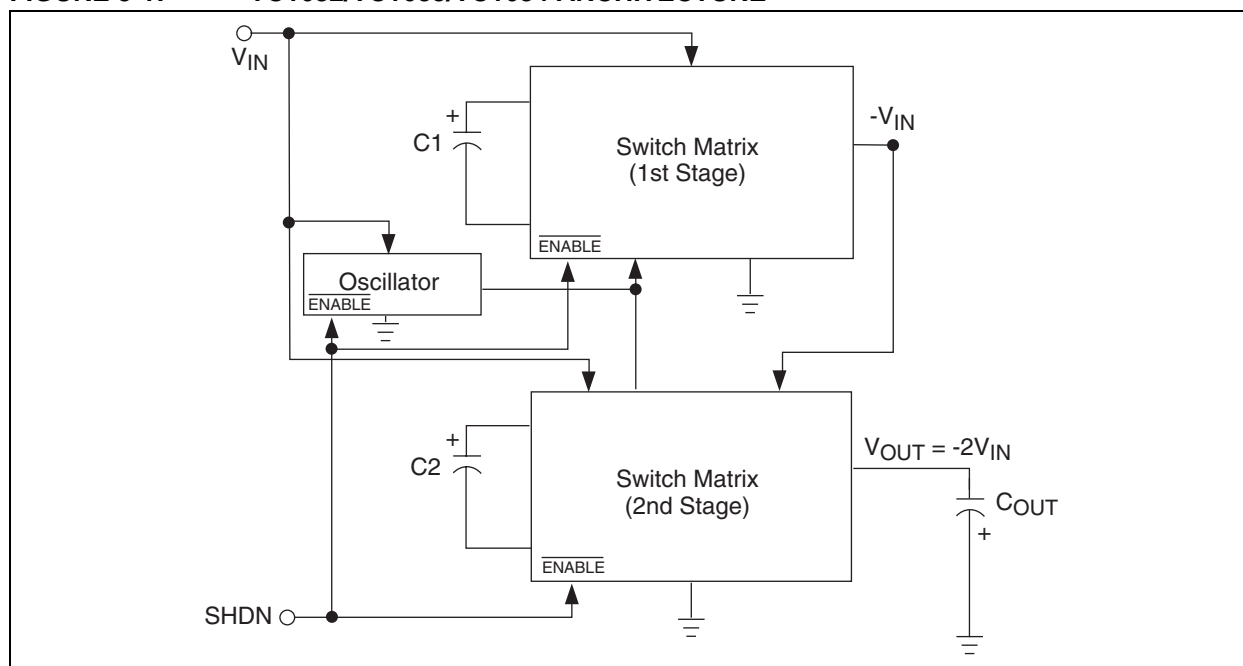

4.0 APPLICATIONS INFORMATION

4.1 Output Voltage Considerations

The TC1682/TC1683/TC1684 perform inverting voltage conversions but do not provide any type of regulation. The output voltage will droop in a linear manner with respect to the output load current. The value of the equivalent output resistance is approximately 120Ω nominal at +25°C and $V_{IN} = +5V$. In this particular case, the output is approximately -10V at very light loads and will droop according to the equation below:

$$V_{DROOP} = I_{OUT} \times R_{OUT}$$

4.2 Capacitor Selection

In order to maintain the lowest output resistance and output ripple voltage, it is recommended that low ESR capacitors be used. Additionally, larger values of C1 and C2 will lower the output resistance and larger values of C_{OUT} will reduce output ripple.

Note: For proper charge pump operation, C1 must have a voltage rating greater than or equal to V_{IN} , while C2 and C_{OUT} must have a voltage rating greater than or equal to $2V_{IN}$.

Table 4-1 shows various values of C1/C2 and the corresponding output resistance values for $V_{IN} = 5V$ @ +25°C.

Table 4-2 shows the output voltage ripple for various values of C_{OUT} (again assuming $V_{IN} = 5V$ @ +25°C). The V_{RIPPLE} values assume a 1mA output load current and a 0.1Ω $ESR_{C_{OUT}}$.

TABLE 4-1: OUTPUT RESISTANCE VS. C1/C2 (ESR = 0.1Ω)

C1, C2 (μF)	TC1682 $R_{OUT}(\Omega)$	TC1683 $R_{OUT}(\Omega)$	TC1684 $R_{OUT}(\Omega)$
0.33	633	184	120
1	262	120	102
3.3	120	95	84

TABLE 4-2: OUTPUT VOLTAGE RIPPLE VS. C_{OUT2} (ESR = 0.1Ω) $I_{OUT} = 1mA$

C_{OUT} (μF)	TC1682 V_{RIPPLE} (mV)	TC1683 V_{RIPPLE} (mV)	TC1684 V_{RIPPLE} (mV)
0.33	192	60	27
1	63	21	16
3.3	17	8	7

4.3 Input Supply Bypassing

The V_{IN} input should be capacitively bypassed to reduce AC impedance and minimize noise effects due to the switching internal to the device. It is recommended that a large value capacitor (at least equal to C1) be connected from V_{IN} to GND for optimal circuit performance.

4.4 Shutdown Input

The TC1682/TC1683/TC1684 is enabled when SHDN is low, and disabled when SHDN is high. This input cannot be allowed to float. (If SHDN is not required, see the TC2682/TC2683/TC2684 data sheet.) The SHDN input should be limited to 0.3V above V_{IN} .

4.5 Inverting Voltage Doubler

The most common application for the TC1682/TC1683/TC1684 devices is the inverting voltage doubler (Figure 4-1). This application uses three external capacitors: C1, C2 and C_{OUT} .

Note: A power supply bypass capacitor is recommended.

The output is equal to $-2V_{IN}$ plus any voltage drops due to loading. Refer to Table 4-1 and Table 4-2 for capacitor selection guidelines.

FIGURE 4-1: INVERTING VOLTAGE DOUBLER TEST CIRCUIT

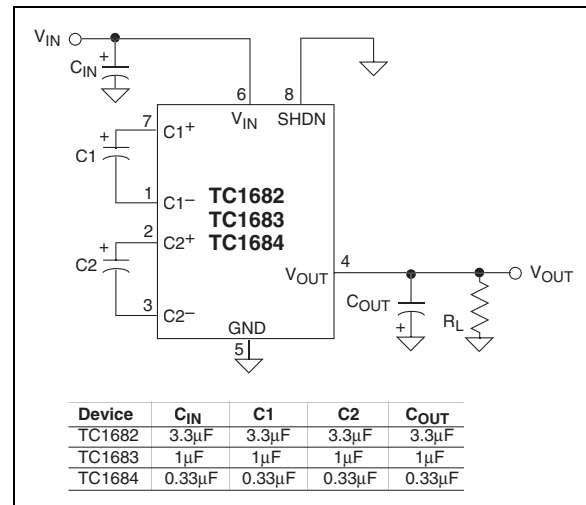

4.6 Layout Considerations

As with any switching power supply circuit, good layout practice is recommended. Mount components as close together as possible to minimize stray inductance and capacitance. Also use a large ground plane to minimize noise leakage into other circuitry.

TC1682/TC1683/TC1684

5.0 PACKAGING INFORMATION

5.1 Package Marking Information

Package marking data not available at this time.

5.2 Taping Form

Component Taping Orientation for 8-Pin MSOP Devices

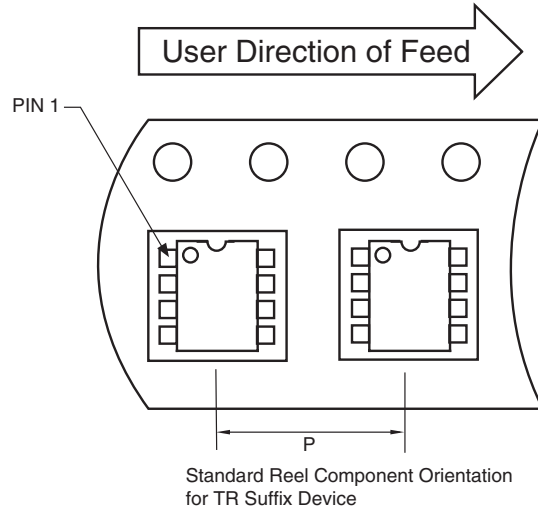

Carrier Tape, Number of Components Per Reel and Reel Size

Package	Carrier Width (W)	Pitch (P)	Part Per Full Reel	Reel Size
8-Pin MSOP	12 mm	8 mm	2500	13 in

5.3 Package Dimensions

8-Pin MSOP

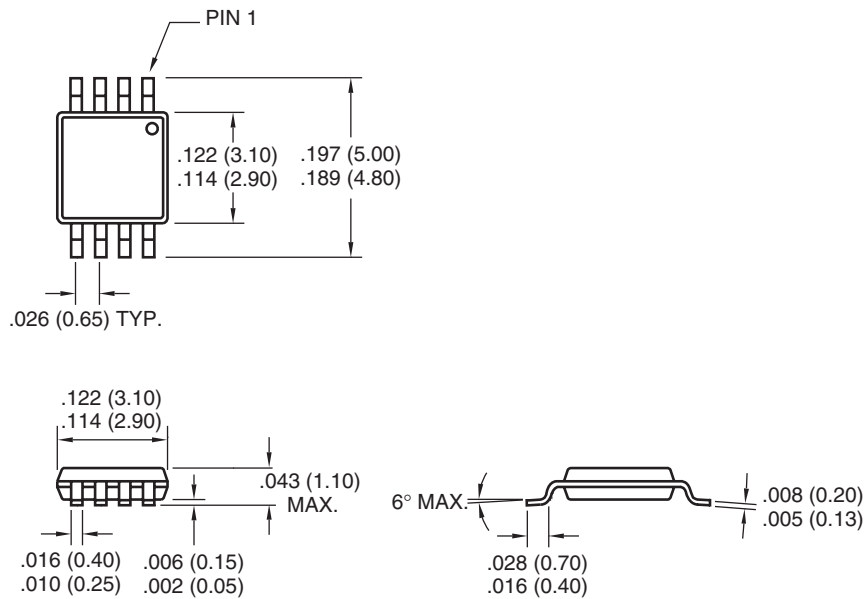

Dimensions: inches (mm)

Sales and Support

Data Sheets

Products supported by a preliminary Data Sheet may have an errata sheet describing minor operational differences and recommended workarounds. To determine if an errata sheet exists for a particular device, please contact one of the following:

1. Your local Microchip sales office
2. The Microchip Corporate Literature Center U.S. FAX: (480) 792-7277
3. The Microchip Worldwide Site (www.microchip.com)

Please specify which device, revision of silicon and Data Sheet (include Literature #) you are using.

New Customer Notification System

Register on our web site (www.microchip.com/cn) to receive the most current information on our products.

TC1682/TC1683/TC1684

NOTES:

Note the following details of the code protection feature on Microchip devices:

- Microchip products meet the specification contained in their particular Microchip Data Sheet.
- Microchip believes that its family of products is one of the most secure families of its kind on the market today, when used in the intended manner and under normal conditions.
- There are dishonest and possibly illegal methods used to breach the code protection feature. All of these methods, to our knowledge, require using the Microchip products in a manner outside the operating specifications contained in Microchip's Data Sheets. Most likely, the person doing so is engaged in theft of intellectual property.
- Microchip is willing to work with the customer who is concerned about the integrity of their code.
- Neither Microchip nor any other semiconductor manufacturer can guarantee the security of their code. Code protection does not mean that we are guaranteeing the product as "unbreakable."

Code protection is constantly evolving. We at Microchip are committed to continuously improving the code protection features of our products. Attempts to break Microchip's code protection feature may be a violation of the Digital Millennium Copyright Act. If such acts allow unauthorized access to your software or other copyrighted work, you may have a right to sue for relief under that Act.

Information contained in this publication regarding device applications and the like is provided only for your convenience and may be superseded by updates. It is your responsibility to ensure that your application meets with your specifications. MICROCHIP MAKES NO REPRESENTATIONS OR WARRANTIES OF ANY KIND WHETHER EXPRESS OR IMPLIED, WRITTEN OR ORAL, STATUTORY OR OTHERWISE, RELATED TO THE INFORMATION, INCLUDING BUT NOT LIMITED TO ITS CONDITION, QUALITY, PERFORMANCE, MERCHANTABILITY OR FITNESS FOR PURPOSE. Microchip disclaims all liability arising from this information and its use. Use of Microchip's products as critical components in life support systems is not authorized except with express written approval by Microchip. No licenses are conveyed, implicitly or otherwise, under any Microchip intellectual property rights.

Trademarks

The Microchip name and logo, the Microchip logo, Accuron, dsPIC, KEELOQ, microID, MPLAB, PIC, PICmicro, PICSTART, PRO MATE, PowerSmart, rPIC, and SmartShunt are registered trademarks of Microchip Technology Incorporated in the U.S.A. and other countries.

AmpLab, FilterLab, Migratable Memory, MXDEV, MXLAB, PICMASTER, SEEVAL, SmartSensor and The Embedded Control Solutions Company are registered trademarks of Microchip Technology Incorporated in the U.S.A.

Analog-for-the-Digital Age, Application Maestro, dsPICDEM, dsPICDEM.net, dsPICworks, ECAN, ECONOMONITOR, FanSense, FlexROM, fuzzyLAB, In-Circuit Serial Programming, ICSP, ICEPIC, Linear Active Thermistor, MPASM, MPLIB, MPLINK, MPSIM, PCKIT, PICDEM, PICDEM.net, PICLAB, PICtail, PowerCal, PowerInfo, PowerMate, PowerTool, rLAB, rPICDEM, Select Mode, Smart Serial, SmartTel, Total Endurance and WiperLock are trademarks of Microchip Technology Incorporated in the U.S.A. and other countries.

SQTP is a service mark of Microchip Technology Incorporated in the U.S.A.

All other trademarks mentioned herein are property of their respective companies.

© 2005, Microchip Technology Incorporated, Printed in the U.S.A., All Rights Reserved.

 Printed on recycled paper.

**QUALITY MANAGEMENT SYSTEM
CERTIFIED BY DNV
== ISO/TS 16949:2002 ==**

Microchip received ISO/TS-16949:2002 quality system certification for its worldwide headquarters, design and wafer fabrication facilities in Chandler and Tempe, Arizona and Mountain View, California in October 2003. The Company's quality system processes and procedures are for its PICmicro® 8-bit MCUs, KEELOQ® code hopping devices, Serial EEPROMs, microperipherals, nonvolatile memory and analog products. In addition, Microchip's quality system for the design and manufacture of development systems is ISO 9001:2000 certified.



WORLDWIDE SALES AND SERVICE

AMERICAS

Corporate Office

2355 West Chandler Blvd.
Chandler, AZ 85224-6199
Tel: 480-792-7200
Fax: 480-792-7277
Technical Support:
<http://support.microchip.com>
Web Address:
www.microchip.com

Atlanta

Alpharetta, GA
Tel: 770-640-0034
Fax: 770-640-0307

Boston

Westborough, MA
Tel: 774-760-0087
Fax: 774-760-0088

Chicago

Itasca, IL
Tel: 630-285-0071
Fax: 630-285-0075

Dallas

Addison, TX
Tel: 972-818-7423
Fax: 972-818-2924

Detroit

Farmington Hills, MI
Tel: 248-538-2250
Fax: 248-538-2260

Kokomo

Kokomo, IN
Tel: 765-864-8360
Fax: 765-864-8387

Los Angeles

Mission Viejo, CA
Tel: 949-462-9523
Fax: 949-462-9608

San Jose

Mountain View, CA
Tel: 650-215-1444
Fax: 650-961-0286

Toronto

Mississauga, Ontario,
Canada
Tel: 905-673-0699
Fax: 905-673-6509

ASIA/PACIFIC

Australia - Sydney

Tel: 61-2-9868-6733
Fax: 61-2-9868-6755

China - Beijing

Tel: 86-10-8528-2100
Fax: 86-10-8528-2104

China - Chengdu

Tel: 86-28-8676-6200
Fax: 86-28-8676-6599

China - Fuzhou

Tel: 86-591-8750-3506
Fax: 86-591-8750-3521

China - Hong Kong SAR

Tel: 852-2401-1200
Fax: 852-2401-3431

China - Qingdao

Tel: 86-532-8502-7355
Fax: 86-532-8502-7205

China - Shanghai

Tel: 86-21-5407-5533
Fax: 86-21-5407-5066

China - Shenyang

Tel: 86-24-2334-2829
Fax: 86-24-2334-2393

China - Shenzhen

Tel: 86-755-8203-2660
Fax: 86-755-8203-1760

China - Shunde

Tel: 86-757-2839-5507
Fax: 86-757-2839-5571

China - Wuhan

Tel: 86-27-5980-5300
Fax: 86-27-5980-5118

China - Xian

Tel: 86-29-8833-7250
Fax: 86-29-8833-7256

ASIA/PACIFIC

India - Bangalore

Tel: 91-80-2229-0061
Fax: 91-80-2229-0062

India - New Delhi

Tel: 91-11-5160-8631
Fax: 91-11-5160-8632

India - Pune

Tel: 91-20-2566-1512
Fax: 91-20-2566-1513

Japan - Yokohama

Tel: 81-45-471-6166
Fax: 81-45-471-6122

Korea - Gumi

Tel: 82-54-473-4301
Fax: 82-54-473-4302

Korea - Seoul

Tel: 82-2-554-7200
Fax: 82-2-558-5932 or
82-2-558-5934

Malaysia - Penang

Tel: 60-4-646-8870
Fax: 60-4-646-5086

Philippines - Manila

Tel: 63-2-634-9065
Fax: 63-2-634-9069

Singapore

Tel: 65-6334-8870
Fax: 65-6334-8850

Taiwan - Hsin Chu

Tel: 886-3-572-9526
Fax: 886-3-572-6459

Taiwan - Kaohsiung

Tel: 886-7-536-4818
Fax: 886-7-536-4803

Taiwan - Taipei

Tel: 886-2-2500-6610
Fax: 886-2-2508-0102

Thailand - Bangkok

Tel: 66-2-694-1351
Fax: 66-2-694-1350

EUROPE

Austria - Wels

Tel: 43-7242-2244-399
Fax: 43-7242-2244-393

Denmark - Copenhagen

Tel: 45-4450-2828
Fax: 45-4485-2829

France - Paris

Tel: 33-1-69-53-63-20
Fax: 33-1-69-30-90-79

Germany - Munich

Tel: 49-89-627-144-0
Fax: 49-89-627-144-44

Italy - Milan

Tel: 39-0331-742611
Fax: 39-0331-466781

Netherlands - Drunen

Tel: 31-416-690399
Fax: 31-416-690340

Spain - Madrid

Tel: 34-91-708-08-90
Fax: 34-91-708-08-91

UK - Wokingham

Tel: 44-118-921-5869
Fax: 44-118-921-5820