



BCF080T

HIGH EFFICIENCY HETEROJUNCTION POWER FET CHIP (.3 μm x 800 μm)

The BeRex BCF080T is a GaAs Power MESFET whose nominal 0.3 micron gate length and 800 micron gate width make the product ideally suited to applications requiring high OIP3 linearity and low phase noise while providing high-gain and medium power from DC to 26.5 GHz. This product is well suited for either wideband or narrow-band applications. The BCF080T is produced using state of the art metallization and devices from each wafer are screened to insure reliability. These chips utilize Si_3N_4 passivation for increased reliability.

Product Features

- 26.0 dBm Typical Output Power
- 11.0 dB Typical Power Gain @ 12 GHz
- Low Phase Noise
- 0.3 X 800 Micron Recessed Gate

Applications

- Commercial
- Military / Hi-Rel
- Test & Measurement

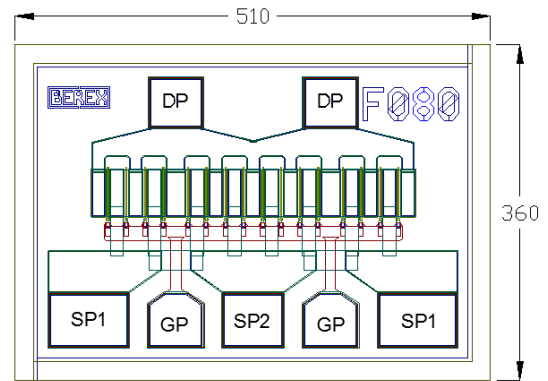

Chip dimensions : 510 X 360 microns
 Gate pad(GP) : 60 X 55 microns
 Drain pad(DP) : 60 X 50 microns
 Source pad1(SP1) : 90 X 65 microns
 Source pad2(SP2) : 70 X 65 microns
 Chip thickness : 100 microns

DC CHARACTERISTIC ($T_a = 25^\circ\text{C}$)

PARAMETER/TEST CONDITIONS		MINIMUM	TYPICAL	MAXIMUM	UNIT
I_{dss}	Saturated Drain Current ($V_{gs} = 0V, V_{ds} = 2V$)	160	240	320	mA
Gm	Transconductance ($V_{ds} = 3V, V_{gs} = 50\% I_{dss}$)	100	130		mS
Vp	Pinch-off Voltage ($I_{ds} = 800 \mu\text{A}, V_{ds} = 3V$)	-3.5	-2.0		V
BV_{gd}	Drain Breakdown Voltage ($I_g = 0.8 \text{ mA}, \text{source open}$)		-15	-11	V
BV_{gs}	Source Breakdown Voltage ($I_g = 0.8 \text{ mA}, \text{drain open}$)		-10	-7	V
R_{th}	Thermal Resistance (Au-Sn Eutectic Attach)		61		$^\circ\text{C/W}$

ELECTRICAL CHARACTERISTIC ($V_{ds} = 8V$, $T_a = 25^\circ C$)

PARAMETER/TEST CONDITIONS		TEST FREQUENCY	MINIMUM	TYPICAL	MAXIMUM	UNIT
P _{1dB}	Output Power @ P _{1dB} ($V_{ds} = 8V$, $I_{ds} = 50\% I_{dss}$)	12 GHZ	24.0	26.0		dBm
		18 GHZ	23.8	25.8		
G _{1dB}	Gain @ P _{1dB} ($V_{ds} = 8V$, $I_{ds} = 50\% I_{dss}$)	12 GHZ	9.2	11.2		dB
		18 GHZ	7.7	9.7		
PAE	PAE @ P _{1dB} ($V_{ds} = 8V$, $I_{ds} = 50\% I_{dss}$)	12 GHZ		27		%
		18 GHZ		30		

ELECTRICAL CHARACTERISTIC ($V_{ds} = 6V$, $T_a = 25^\circ C$)

PARAMETER/TEST CONDITIONS		TEST FREQUENCY	MINIMUM	TYPICAL	MAXIMUM	UNIT
P _{1dB}	Output Power @ P _{1dB} ($V_{ds} = 6V$, $I_{ds} = 50\% I_{dss}$)	12 GHZ	23.5	25.5		dBm
		18 GHZ	23.7	25.7		
G _{1dB}	Gain @ P _{1dB} ($V_{ds} = 6V$, $I_{ds} = 50\% I_{dss}$)	12 GHZ	9.0	11.0		dB
		18 GHZ	7.3	9.3		
PAE	PAE @ P _{1dB} ($V_{ds} = 6V$, $I_{ds} = 50\% I_{dss}$)	12 GHZ		33		%
		18 GHZ		40		

MAXIMUM RATINGS ($T_a = 25^\circ C$)

PARAMETERS		ABSOLUTE	CONTINUOUS
V _{ds}	Drain-Source Voltage	12 V	8 V
V _{gs}	Gate-Source Voltage	-8 V	-4V
I _{ds}	Drain Current	I _{dss}	I _{dss}
I _{gsf}	Forward Gate Current	20 mA	3.2 mA
P _{in}	Input Power	23 dBm	@ 3dB compression
T _{ch}	Channel Temperature	175° C	150° C
T _{stg}	Storage Temperature	-60° C - 150° C	-60° C - 150° C
P _t	Total Power Dissipation	2.3 W	1.9 W

Exceeding any of the above Maximum Ratings will result in reduced MTTF and may cause permanent damage to the device

P_{in}_P_{out}/Gain, PAE (12 GHz)

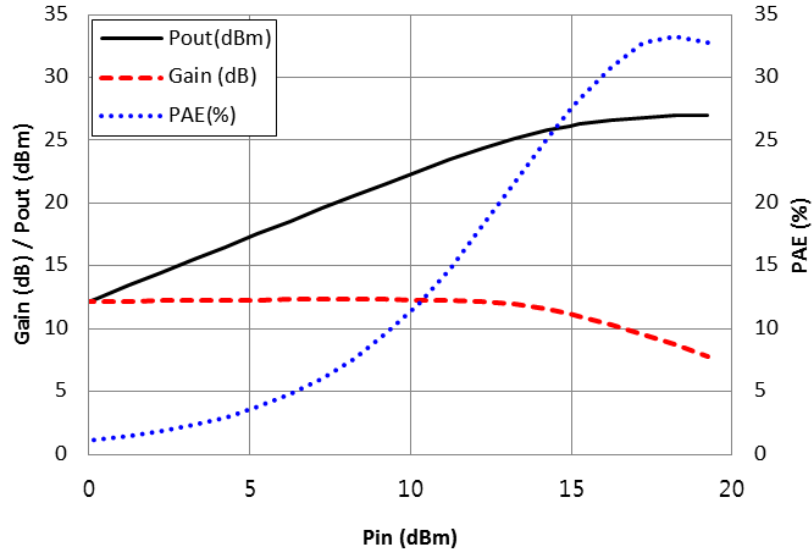

Freq. = 12 GHz, V_{ds} = 8 V, I_{ds} = 50% I_{dss}

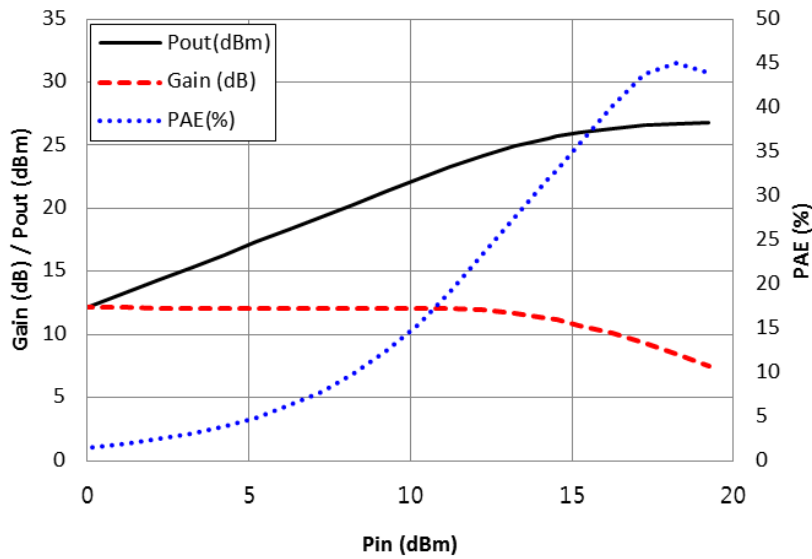

Freq. = 12 GHz, V_{ds} = 6 V, I_{ds} = 50% I_{dss}

P_{in}_P_{out}/Gain, PAE (18GHz)

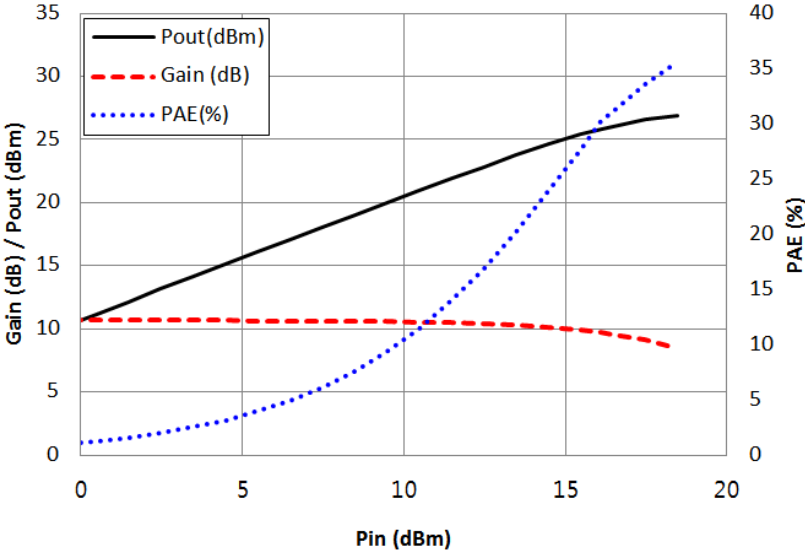

Freq. = 18 GHz, V_{ds} = 8 V, I_{ds} = 50% I_{dss}

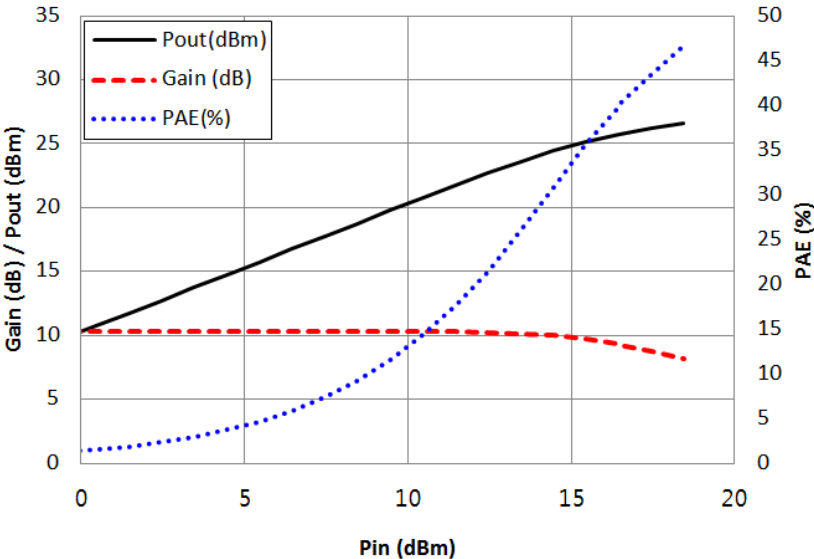

Freq. = 18 GHz, V_{ds} = 6 V, I_{ds} = 50% I_{dss}

Wire Bonding Options

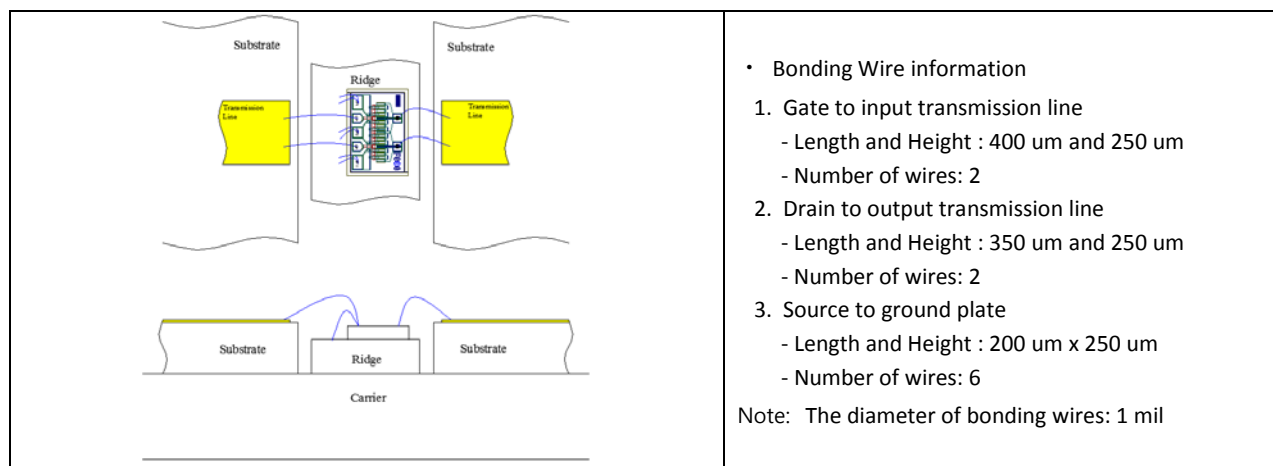

Proper ESD procedures should be followed when handling this device.

DIE ATTACH RECOMMENDATIONS:

BeRex recommends the “Eutectic” die attach using Au-Sn (80%-20%) pre-forms. The die attach station must have accurate temperature control, and the operation should be performed with parts no hotter than 300°C for less than 10 seconds. An inert forming gas (90% N₂-10% H₂) or clean, dry N₂ should be used.

HANDLING PRECAUTIONS:

GaAs FETs are very sensitive to and may be damaged by Electrostatic Discharge (ESD). Therefore, proper ESD precautions must be taken whenever you are handling these devices. It is critically important that all work surfaces, and assembly equipment, as well as the operator be properly grounded when handling these devices to prevent ESD damage.

STORAGE & SHIPPING:

BeRex’s standard chip device shipping package consists of an antistatic “Gel-Pak”, holding the chips, placed inside a sealed antistatic and moisture barrier bag. This packaging is designed to provide a reasonable measure of protection from both mechanical and ESD damage.

Chip devices should be stored in a clean, dry Nitrogen gas environment at room temperature until they are required for assembly. Only open the shipping package or perform die assembly in a work area with a class 10,000 or better clean room environment to prevent contamination of the exposed devices.

CAUTION:

THIS PRODUCT CONTAINS GALLIUM ARSENIDE (GaAs) WHICH CAN BE HAZARDOUS TO THE HUMAN BODY AND THE ENVIRONMENT. THEREFORE, IT MUST BE HANDLED WITH CARE AND IN ACCORDANCE WITH ALL GOVERNMENTAL AND COMPANY REGULATIONS FOR THE SAFE HANDLING AND DISPOSAL OF HAZARDOUS WASTE. DO NOT BURN, DESTROY, CUT, CRUSH OR CHEMICALLY DISSOLVE THE PRODUCT. DO NOT LICK THE PRODUCT OR IN ANY WAY ALLOW IT TO ENTER THE MOUTH. EXCLUDE THE PRODUCT FROM GENERAL INDUSTRIAL WASTE OR GARBAGE AND DISPOSE OF ONLY IN ACCORDANCE TO APPLICABLE LAWS AND/OR ORDINANCES.

DISCLAIMER

BEREX RESERVES THE RIGHT TO MAKE CHANGES WITHOUT FURTHER NOTICE TO ANY PRODUCTS HEREIN TO IMPROVE RELIABILITY, FUNCTION OR DESIGN. BEREX DOES NOT ASSUME ANY LIABILITY ARISING OUT OF THE APPLICATION OR USE OF ANY PRODUCT OR CIRCUIT DESCRIBED HEREIN.

LIFE SUPPORT POLICY

BEREX PRODUCTS ARE NOT AUTHORIZED FOR USE AS CRITICAL COMPONENTS IN LIFE SUPPORT DEVICES WITHOUT THE EXPRESS WRITTEN APPROVAL OF BEREX.

1. Life support devices or systems are devices or systems which (a) are intended for surgical implant into the body, or (b) support or sustain life, or (c) whose failure to perform when properly used in accordance with instructions for use provided in labeling, can be reasonably expected to result in significant injury to the user.
2. A critical component is any component of a life support device or system whose failure to perform can be reasonably expected to cause the failure of the life support device or system, or to affect its safety or effectiveness.