

# BIG8

## 50-600 MHz Internally Matched IF Amplifier



### Device Features

- OIP3 = 41.5 dBm @ 500 MHz
- Gain = 27 dB @ 140 MHz
- Output P1 dB = 21 dBm @ 140 MHz
- NF = 2.7 @ 70MHz at Demo Board



### Product Description

BeRex's BIG8 is a high performance InGaP/ GaAs HBT MMIC amplifier, internally matched to 50 Ohms. The BIG8 is designed for high linearity IF amplifier that require excellent gain ,high OIP3 and flatness. It is packaged in a RoHS-compliant with SOT-89 surface mount package.

### Applications

- Base station Infrastructure/RFID

### Applications Circuit

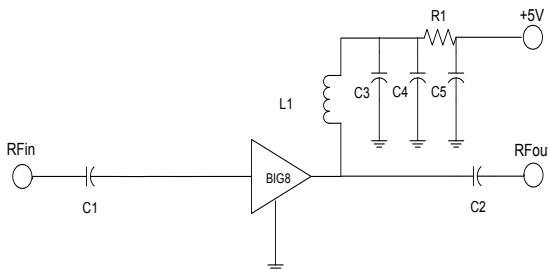

BOM	50~100MHz	100~300MHz	300~600MHz
C1	1000pF	1000pF	100pF
C2	1000pF	1000pF	100pF
C3	100pF	100pF	100pF
C4	1000pF	1000pF	1000pF
C5	10uF	10uF	10uF
L1	1uH	560nH	100nH
R1	1.6ohm	1.6ohm	1.6ohm

### Typical Performance<sup>1</sup>

Parameter	Frequency				Unit
	70	140	200	500	
Gain	27.0	27.0	27.0	26.0	dB
S11	-21.0	-20.0	-20.5	-18.5	dB
S22	-17.5	-18.0	-18.0	-17.5	dB
OIP3 <sup>2</sup>	40.5	40.0	39.0	41.5	dBm
P1dB	20.5	21.0	21.0	20.5	dBm
Noise Figure	2.7	2.9	3.0	3.1	dB

<sup>1</sup> Device performance \_ measured on a BeRex evaluation board at 25°C, 50 Ω system.

<sup>2</sup> OIP3 \_ measured on two tones with a output power 8 dBm/ tone , F2—F1 = 1 MHz.

	Min.	Typical	Max.	Unit
Bandwidth	50		600	MHz
I <sub>c</sub> @ (V <sub>c</sub> = 5V)	83	94	105	mA
V <sub>c</sub>		5		V
dG/dT		-0.004		dB/°C
R <sub>TH</sub>		66.6		°C/W

### Absolute Maximum Ratings

Parameter	Rating	Unit
Operating Case Temperature	-40 to +85	°C
Storage Temperature	-55 to +155	°C
Junction Temperature	+220	°C
Operating Voltage	+7	V
Supply Current	250	mA
Input RF Power	24	dBm

Operation of this device above any of these parameters may result in permanent damage.

# BIG8

## 50-600 MHz Internally Matched IF Amplifier



V-I Characteristics

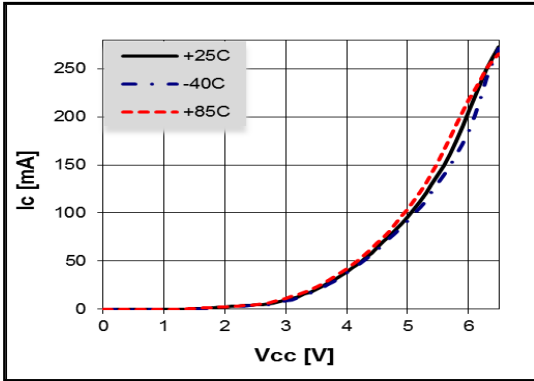

BeRex SOT89 Evaluation Board

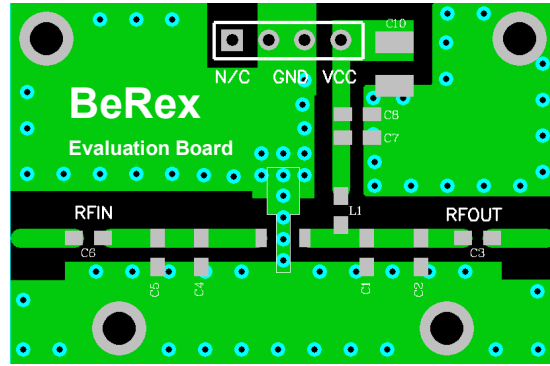

\*Dielectric constant \_ 4.2 \*RF pattern width 52mil \*31mil thick FR4 PCB

Preliminary Datasheet

### Typical Device Data

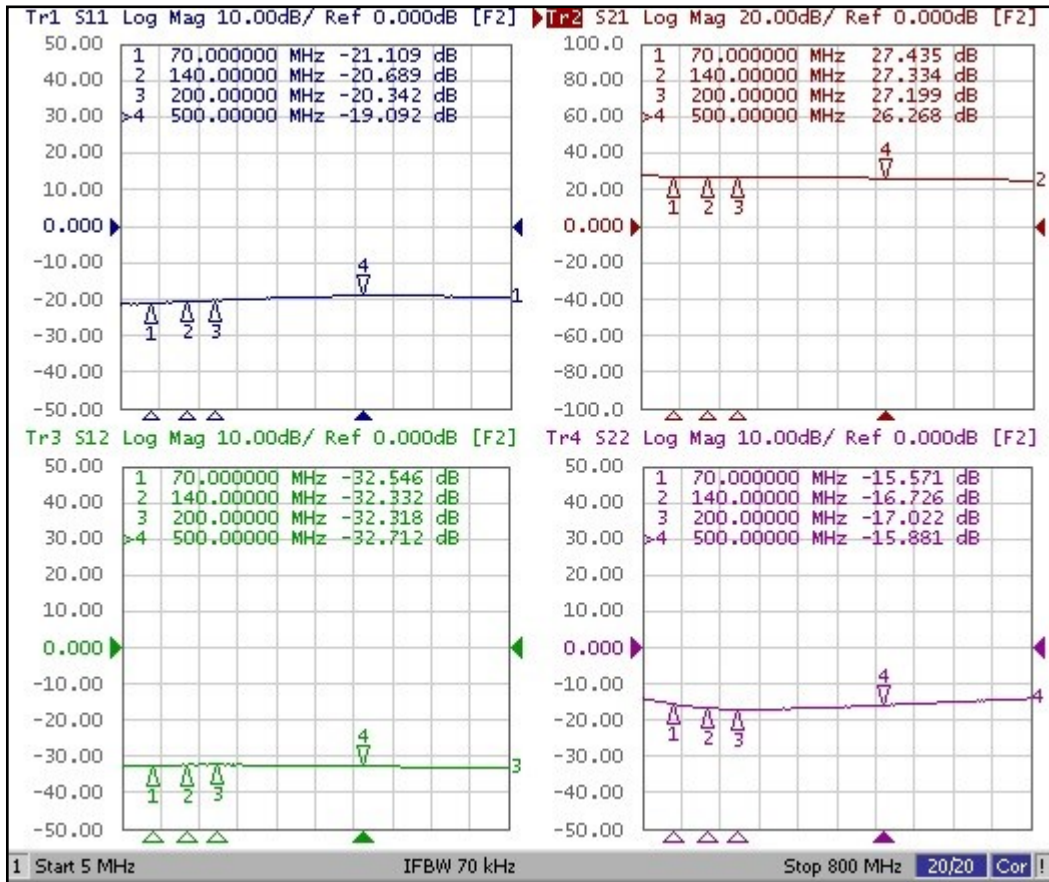

# BIG8



## 50-600 MHz Internally Matched IF Amplifier

### S-Parameter

(V<sub>device</sub> = 5.0V, I<sub>cc</sub> = 94mA, T = 25 °C, calibrated to device leads)

Freq	S11 [Mag]	S11 [Ang]	S21 [Mag]	S21 [Ang]	S12 [Mag]	S12 [Ang]	S22 [Mag]	S22 [Ang]
10	0.09	-162.49	23.38	-179.10	0.023	2.97	0.19	4.87
50	0.09	-173.26	23.23	176.20	0.024	2.42	0.17	-14.29
100	0.09	-173.63	23.07	171.97	0.024	2.27	0.15	-22.65
150	0.09	-173.14	22.84	167.99	0.025	1.63	0.14	-26.46
200	0.10	-173.82	22.54	164.17	0.025	1.14	0.14	-29.49
250	0.10	-173.69	22.22	160.50	0.025	0.99	0.14	-32.38
300	0.10	-172.72	21.80	156.86	0.025	0.76	0.14	-36.27
350	0.10	-174.64	21.47	153.48	0.024	0.66	0.14	-38.76
400	0.11	-176.60	21.09	150.24	0.024	0.93	0.15	-41.05
450	0.11	-177.87	20.65	146.99	0.024	0.92	0.15	-44.18
500	0.11	179.34	20.27	144.05	0.024	1.25	0.15	-46.40
550	0.11	175.61	19.86	140.85	0.023	1.48	0.16	-48.84
600	0.11	172.99	19.39	137.92	0.023	1.79	0.17	-51.58

Preliminary Datasheet

# BIG8



## 50-600 MHz Internally Matched IF Amplifier

### Application Circuit: 70-500 MHz

Typical Performance (Vd = 5V, Ic = 94mA, T = 25°C)

Freq	MHz	70	140	200	500
S21	dB	27.0	27.1	26.9	26.0
S11	dB	-21.0	-20.1	-20.4	-18.6
S22	dB	-17.5	-17.8	-18.6	-17.7
P1	dBm	20.7	21	21	20.2
OIP3	dBm	40.5	40.2	39	41.6
NF	dB	2.7	2.9	3.0	3.2

Typical Performance (Vd = 4.7V, Ic = 78mA, T = 25°C)

Freq	MHz	70	140	200	500
S21	dB	26.9	26.9	26.7	25.8
S11	dB	-21.8	-21.6	-21.8	-20.0
S22	dB	-16.7	-16.9	-17.2	-16.5
P1	dBm	20.0	20.1	20.1	19.4
OIP3	dBm	37.5	37.6	36.1	37.5
NF	dB	2.8	2.8	2.8	3.0

Typical Performance (Vd = 4.5V, Ic = 66mA, T = 25°C)

Freq	MHz	70	140	250	500
S21	dB	26.7	26.7	26.5	25.7
S11	dB	-23.3	-23.3	-23.7	-21.1
S22	dB	-15.8	-15.9	-16.2	-15.6
P1	dBm	19.1	19.2	19.1	18.4
OIP3	dBm	34.8	34.9	33.7	34.5
NF	dB	2.8	2.8	2.8	2.9

Typical Performance (Vd = 4V, Ic = 40mA, T = 25°C)

Freq	MHz	70	140	250	500
S21	dB	25.8	25.9	25.7	25.0
S11	dB	-26.8	-29.8	-33.7	-26.9
S22	dB	-12.9	-12.8	-13.0	-12.7
P1	dBm	16.2	16.2	15.5	14.5
OIP3	dBm	28.2	28.3	27.3	25.8
NF	dB	2.7	2.7	2.6	2.7

# BIG8



## 50-600 MHz Internally Matched IF Amplifier

### Device Performance

#### Pin-Pout-Gain

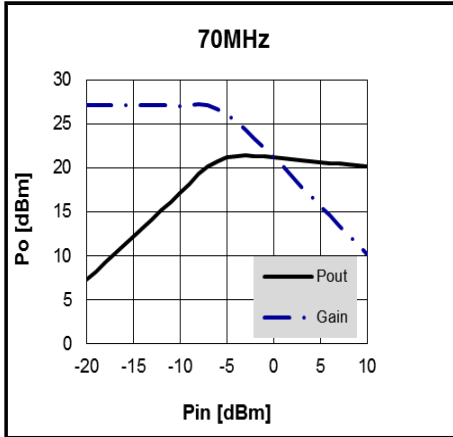

70MHz, 5V/94mA

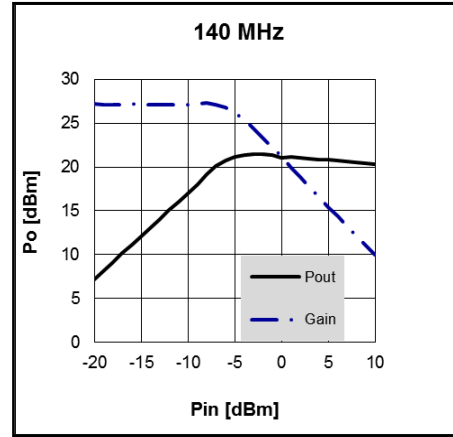

140MHz, 5V/94mA

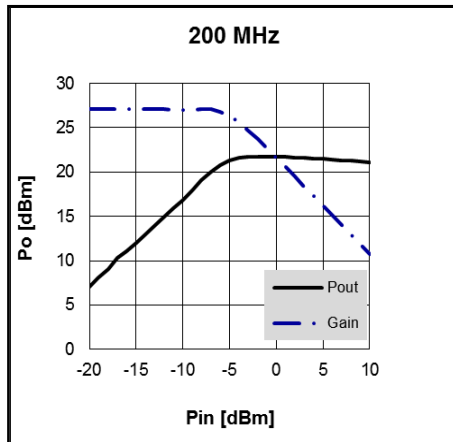

200MHz, 5V/94mA

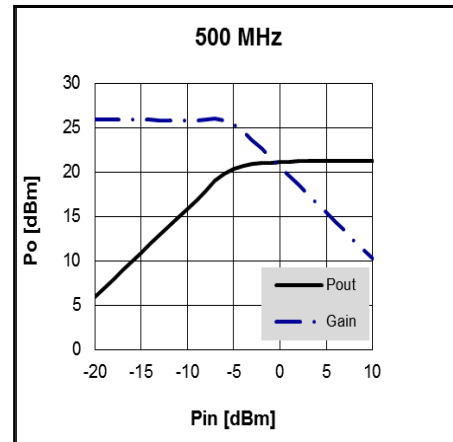

500MHz, 5V/94mA

Preliminary Datasheet

# BIG8

## 50-600 MHz Internally Matched IF Amplifier



Preliminary Datasheet

### OIP3

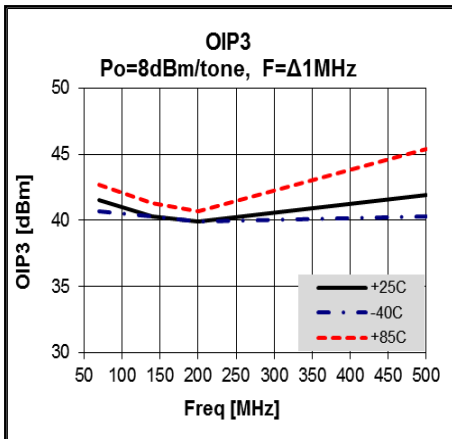
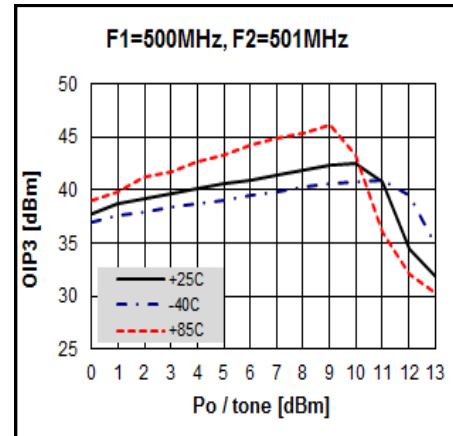
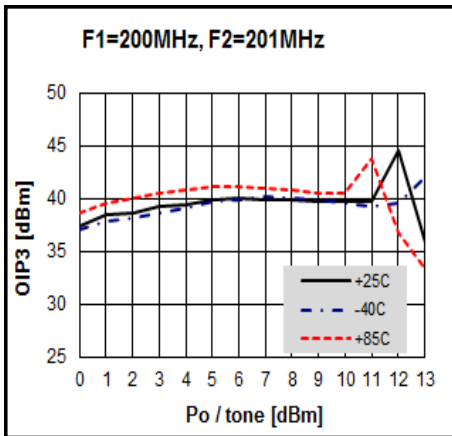
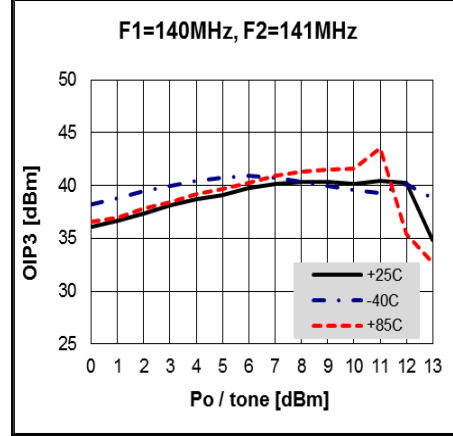
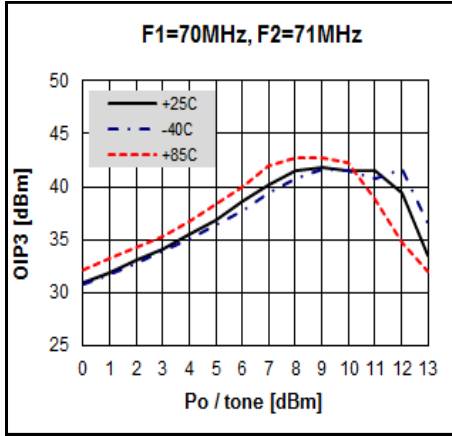

# BIG8

## 50-600 MHz Internally Matched IF Amplifier



Preliminary Datasheet

### ACLR / LTE

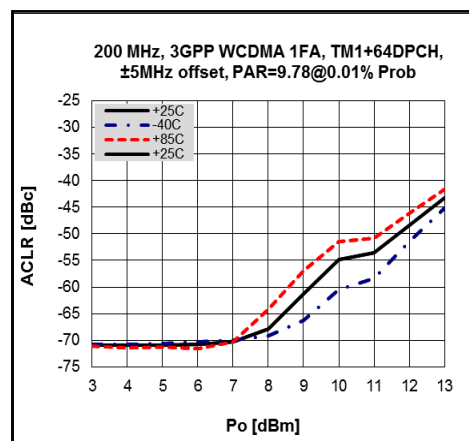
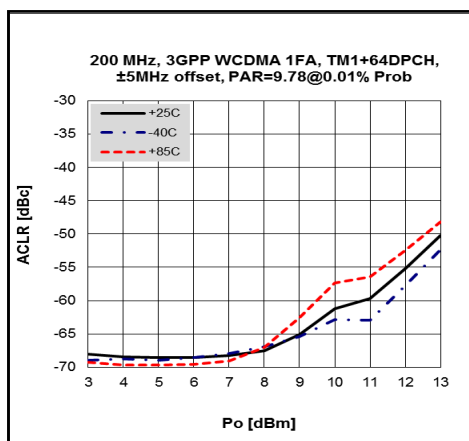
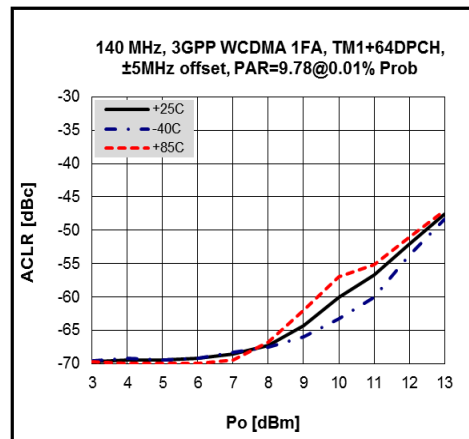
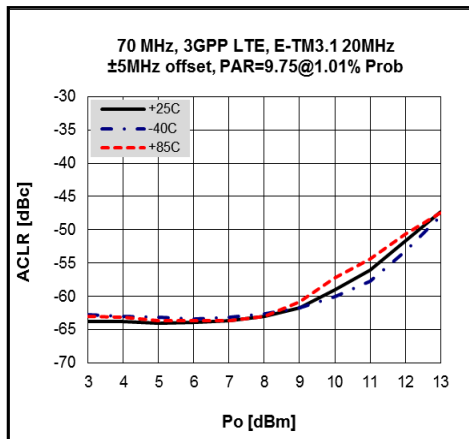
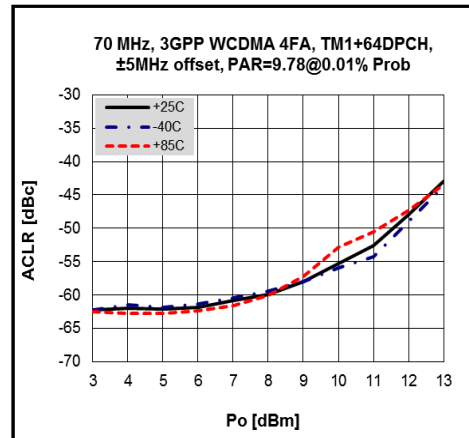
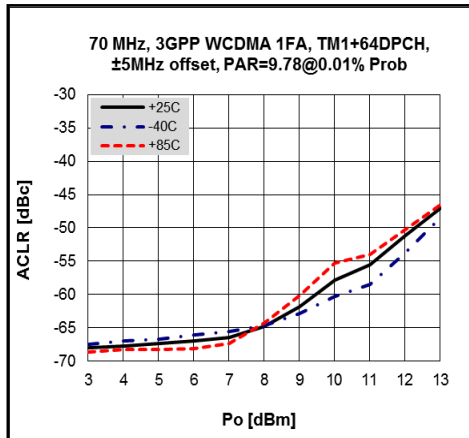

# BIG8



## 50-600 MHz Internally Matched IF Amplifier

Preliminary Datasheet

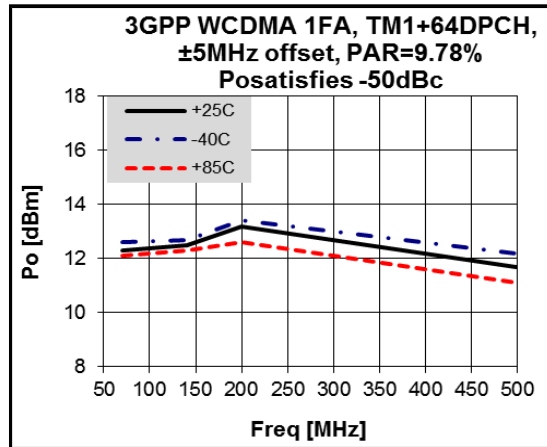

### S-Parameters over Temperature (70MHz)

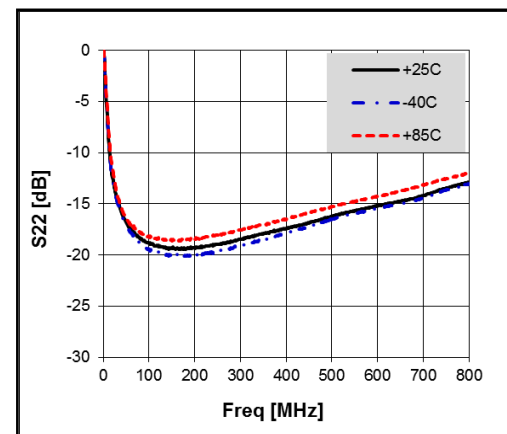
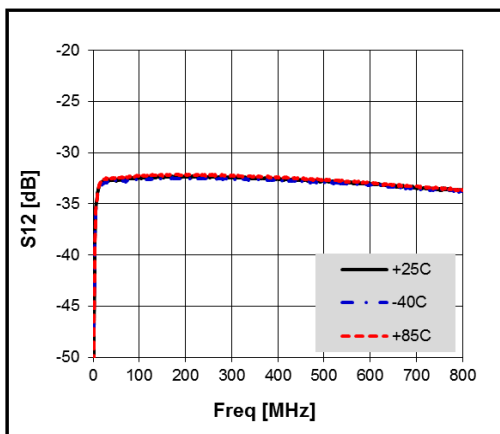
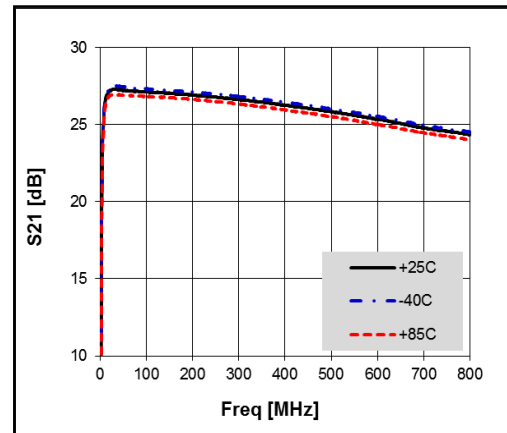
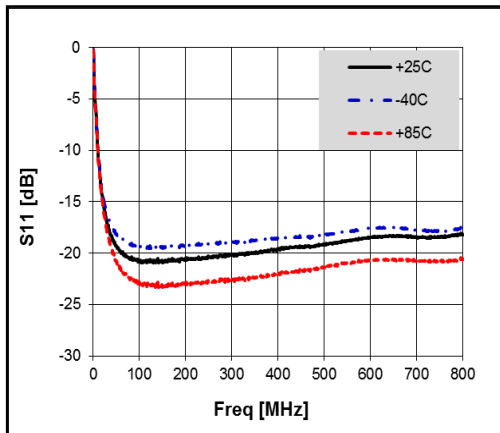

# BIG8



## 50-600 MHz Internally Matched IF Amplifier

### S-Parameters over Temperature (140MHz,200MHz)

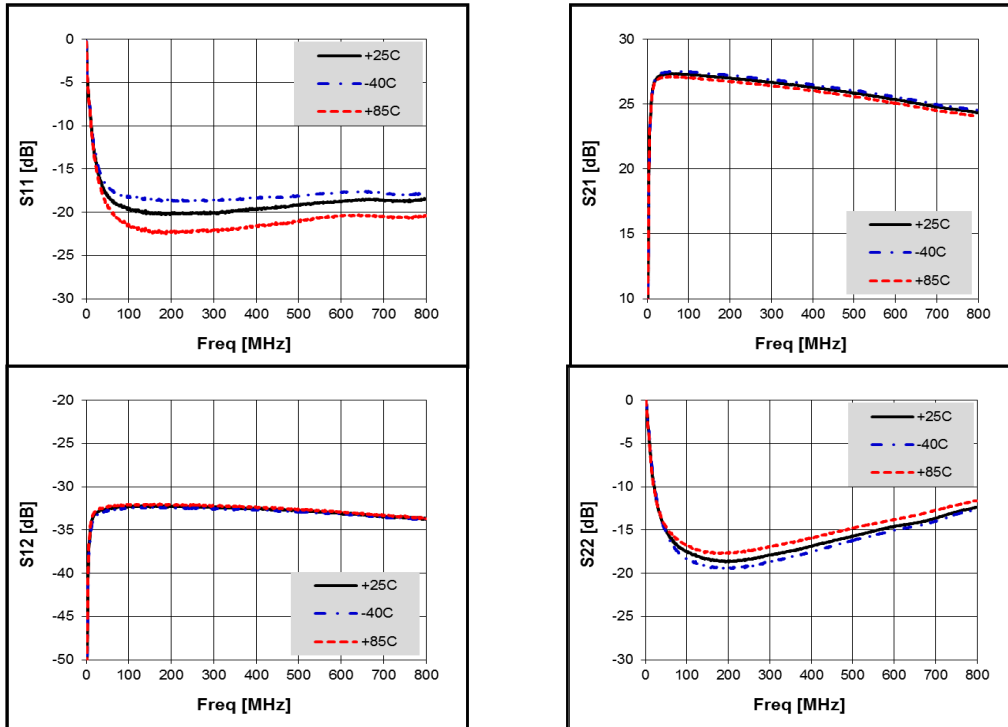

### S-Parameters over Temperature (500MHz)

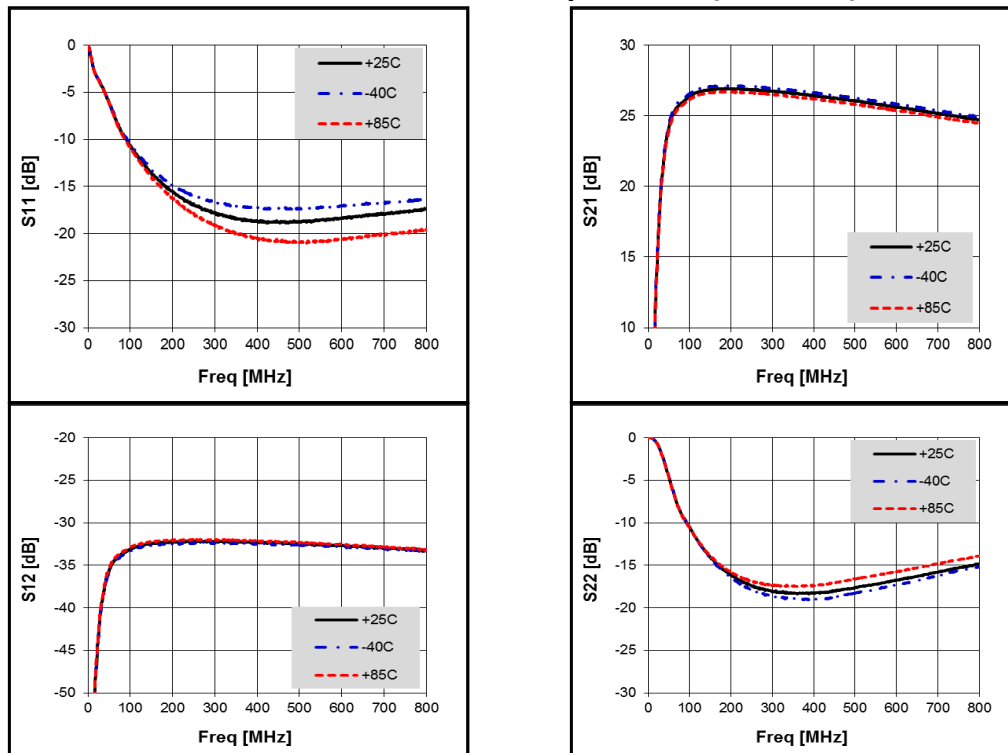

Preliminary Datasheet

# BIG8

## 50-600 MHz Internally Matched IF Amplifier



Preliminary Datasheet

### Package Outline Dimension

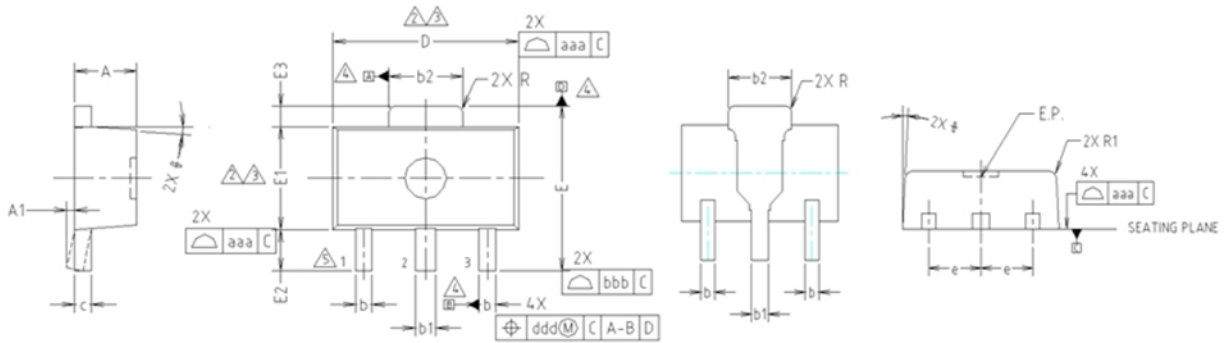

- NOTE:**  
1. DIMENSIONS IN MILLIMETERS.
- ⚠ DIMENSION D DOES NOT INCLUDE MOLD FLASH, PROTRUSIONS OR GATE BURRS. MOLD FLASH, PROTRUSIONS OR GATE BURRS SHALL NOT EXCEED 0.5mm PER END. DIMENSION E1 DOES NOT INCLUDE INTERLEAD FLASH OR PROTRUSION. INTERLEAD FLASH OR PROTRUSION SHALL NOT EXCEED 0.5mm PER SIDE.
  - ⚠ DIMENSIONS D AND E1 ARE DETERMINED AT THE OUTMOST EXTREMES OF THE PLASTIC BODY EXCLUSIVE OF MOLD FLASH, TIE BAR BURRS, GATE BURRS AND INTERLEAD FLASH, BUT INCLUDING ANY MISMATCH BETWEEN THE TOP AND BOTTOM OF THE PLASTIC BODY.
  - ⚠ DATUMS A, B AND D TO BE DETERMINED 0.18mm FROM THE LEAD TIP.
  - ⚠ TERMINAL NUMBERS ARE SHOWN FOR REFERENCE ONLY.

SYMBOL	MILLIMETERS			NOTE
	MINIMUM	NOMINAL	MAXIMUM	
A	1.40	1.50	1.60	
A1	0.00	—	0.10	
b	0.38	0.42	0.48	
b1	0.48	0.52	0.58	
b2	1.79	1.82	1.87	
c	0.40	0.42	0.46	
D	4.40	4.50	4.70	2,3
E	3.70	4.00	4.30	2,3
E1	2.40	2.50	2.70	2,3
E2	0.80	1.00	1.20	
E3	0.40	0.50	0.60	
e	1.50 TYP.			
φ	4° TYP.			
R	0.15 TYP.			
R1	—	—	0.20	
SYMBOL	TOLERANCES OF FORM AND POSITION		NOTE	
aaa	0.15			
bbb	0.20			
ccc	0.10			
ddd	0.10			

### Suggested PCB Land Pattern and PAD Layout

PCB Land Pattern

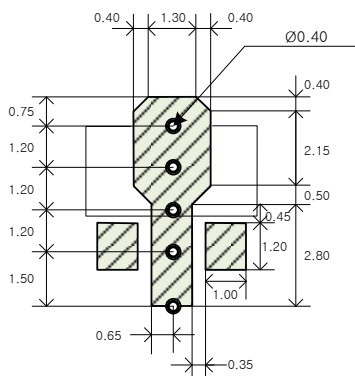

Note : All dimension \_ millimeters

PCB lay out \_ on BeRex website

PCB Mounting

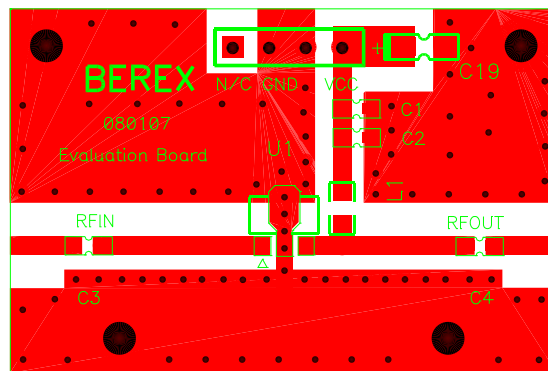

# BIG8

50-600 MHz Internally Matched IF Amplifier



## Package Marking

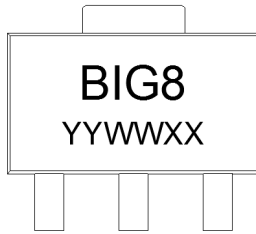

YY = Year, WW = Working Week,  
XX = Wafer No.

## Tape & Reel

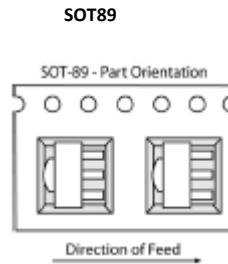

Packaging information:

Tape Width (mm): 12  
Reel Size (inches): 7  
Device Cavity Pitch (mm): 8  
Devices Per Reel: 1000

## Lead plating finish

100% Tin Matte finish

(All BeRex products undergoes a 1 hour, 150 degree C, Anneal bake to eliminate thin whisker growth concerns.)

## MSL / ESD Rating

<b>ESD Rating:</b>	Class 2
<b>Value:</b>	Passes <4000V
<b>Test:</b>	Human Body Model (HBM)
<b>Standard:</b>	JEDEC Standard JESD22-A114
<b>MSL Rating:</b>	Level 1 at +265°C convection reflow
<b>Standard:</b>	JEDEC Standard J-STD-020

## NATO CAGE code:

2	N	9	6	F
---	---	---	---	---