

## Outdoor Thermoelectric Cooler Assemblies



\* Patent Pending

### THERMOELECTRIC COOLING UNITS FOR OUTDOOR ENCLOSURES AND KIOSKS

The Outdoor Cooler Series is an Air-to-Air thermoelectric assembly (TEA) that uses impingement flow to transfer heat. It offers dependable, compact performance by cooling objects via convection. The AA-250 has 26% higher cooling capacity and a 21% boost in efficiency over standard models with same geometric configurations. Heat is absorbed and dissipated thru custom designed heat exchangers with high aspect ratio, air ducted shrouds and high performance fans. The heat pumping action occurs from custom designed thermoelectric modules that achieve a high coefficient of performance (COP) to minimize power consumption.

This product series has been designed to pass rigorous Telcordia test requirements conducted by our customers, such as earthquake resistance, salt fog, wind-driven rain, high temperature exposure and dust contaminants. This is due to the selection of world class components such as brand fans with the highest degree of environmental protection and lifetime guaranteed waterproof connectors, heavy duty anodization on the high-density heat sinks, overheat protection, and double environmental seals for the thermoelectric modules.

### FEATURES AND BENEFITS

- 244W capacity rated at  $\Delta T = 0^{\circ}\text{C}$ ,  $T_{\text{ambient}} = 35^{\circ}\text{C}$
- Wide operating temperature range of  $-40^{\circ}\text{C}$  to  $+55^{\circ}\text{C}$
- Telcordia GR-487-CORE tested and verified by customers when integrated in telecom outdoor enclosures
- Gaskets, connectors, and fans provide a NEMA 4 seal for the enclosure
- UL60950 and UL50 approval obtained by customers when integrated in telecom outdoor enclosures
- Environmentally friendly solid state operation – no compressor or CFC refrigerants
- Cooling and heating in the same unit; optional temperature controller reverses the polarity of current to generate heating

### APPLICATIONS

- Outdoor telecom enclosures
- Outdoor kiosks and displays
- Harsh condition electronic cabinets
- Battery cabinets

**global solutions: local support™**

Americas: +1.888.246.9050

Europe: +46.31.420.530

Asia: +86.755.2714.1166

# AA-250-24-44-00-XX Outdoor Thermoelectric Cooler Assemblies

**PERFORMANCE  $Q_c$  VS  $\Delta T$**

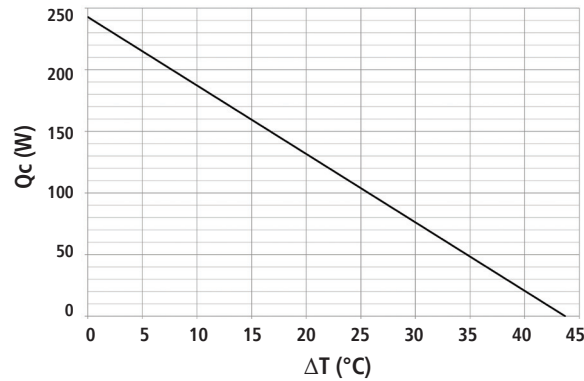

| SPECIFICATIONS  | AA-250-24-44-00-XX   |
|---|--|
| <b>Technical</b>  |  |
| Technology  | Thermoelectric (TE) modules, forced air, closed loop (non-mixing), filter-less, non-refrigerant    |
| Cooling at $dT = 0^{\circ}\text{C}$ , and nominal / float voltage. <sup>1</sup> | 244/262 W (832/894 BTU/hr)   |
| Heating <sup>2</sup>  | 250W (853 BTU/hr)  |
| Voltage (nominal / maximum) <sup>6</sup>  | 24/28 VDC  |
| COP (Coefficient of Performance)  | 85%  |
| Grounding (all voltages)  | Positive or negative   |
| Current draw, $\pm 10\%$ (nominal / startup)                                    | 12.1/15.1 A  |
| Weight  | 6.3 kg (16.9 lbs)  |
| Panel mounting  | Through (from external side)   |
| Fan life ( $L_{10}$ at $+40^{\circ}\text{C}$ )                                  | $\geq 70,000$ hours  |
| Connector type (on unit / mating side)  | Terminal block with cage clamps (AWG 28-12)  |
| Hi-pot testing  | 707 VDC  |
| <b>Environmental</b>  |  |
| Temperature range <sup>3</sup> (external ambient)                               | $-40^{\circ}\text{C}$ to $+55^{\circ}\text{C}$ ( $-40^{\circ}\text{F}$ to $+131^{\circ}\text{F}$ ) |
| Temperature range (internal enclosure)  | $-20^{\circ}\text{C}$ to $+55^{\circ}\text{C}$ ( $-4^{\circ}\text{F}$ to $+131^{\circ}\text{F}$ )  |
| Degree of protection, enclosure <sup>4</sup>                                    | NEMA 4 (IP55)  |
| Degree of protection, unit internal side <sup>5</sup>                           | IP54   |
| Degree of protection, unit external side <sup>5</sup>                           | IP54   |
| Sound level (1m distance)   | 63 dB(A)   |
| Over-Temp Thermostat (internal and external side heat sink)                     | $75^{\circ}\text{C} \pm 6^{\circ}\text{C}$ (accessory)   |

<sup>1</sup> Cooling capacities at nominal / float voltage are rated at external temperatures of  $+35^{\circ}\text{C}$  and  $+50^{\circ}\text{C}$  respectively. Float voltage is defined at 27 VDC

<sup>2</sup> Calculated heating capacity is rated at external temperature of  $-40^{\circ}\text{C}$ , nominal voltage, and  $\Delta T = -45^{\circ}\text{C}$ .

<sup>3</sup> Controller function shall not operate the external fan during heating mode.

<sup>4</sup> The highest environmental protection level requires an external shroud and is defined as the protection level for the enclosure.

<sup>5</sup> Rating for unit without protective shroud.

<sup>6</sup> Max ripple 5%.

Note: The specified performance of any Laird Technologies cooling unit is dependent on how it is handled and incorporated into the final product. This includes elements such as the system design, insulation design, and assembly method. While Laird Technologies is able to provide general guidelines based upon our experience, it is ultimately the responsibility of the device manufacturer to validate each product and its performance for its intended use.

# AA-250-24-44-00-XX Outdoor Thermoelectric Cooler Assemblies

## ISOMETRIC DRAWINGS

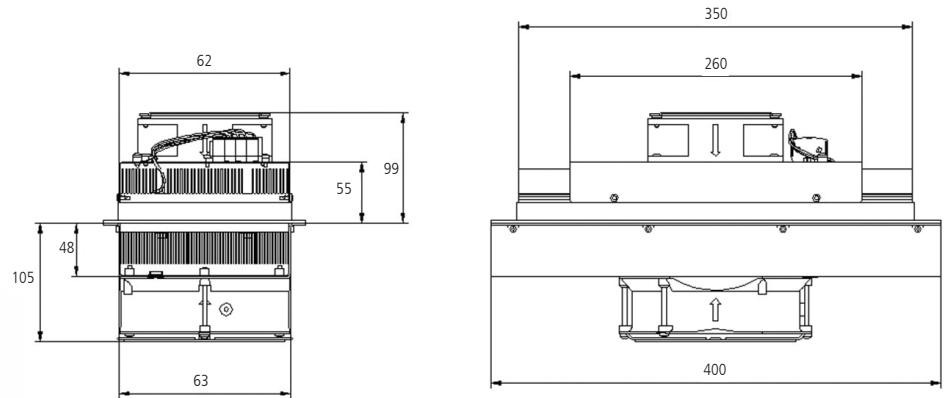

## MOUNTING HOLE LOCATION & HARDWARE

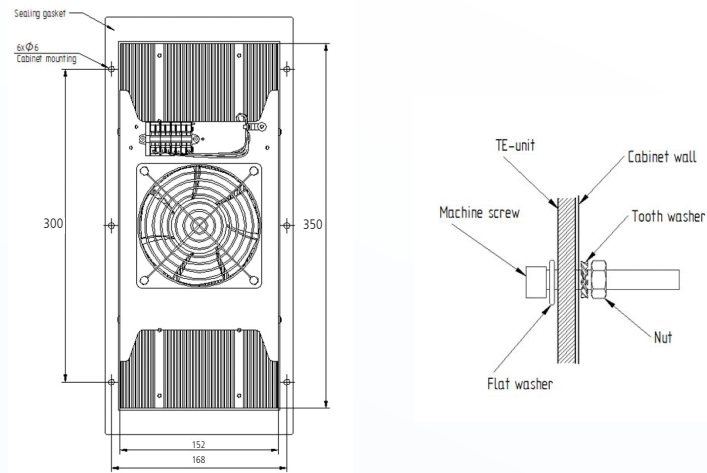

## ELECTRICAL CONNECTION 24VDC (CAGE CLAMP)

