

TC125/TC126

PFM Step-Up DC/DC Regulators

Features:

- Assured Start-up at 0.9V
- PFM (100 kHz Max. Operating Frequency)
- 40 μ A Maximum Supply Current ($V_{OUT} = 3V @ 30 mA$)
- 0.5 μ A Shutdown Mode (TC125)
- Voltage Sense Input (TC126)
- Requires Only Three External Components
- 80 mA Maximum Output Current
- Small Package: 5-Pin SOT-23

Applications:

- Palmtops/PDAs
- Battery-Operated Systems
- Cameras
- Portable Communicators

Device Selection Table

Part Number	Output Voltage (V)*	Package	Operating Temp. Range
TC125501ECT	5.0	5-Pin SOT-23	-40°C to +85°C
TC125331ECT	3.3	5-Pin SOT-23	-40°C to +85°C
TC125301ECT	3.0	5-Pin SOT-23	-40°C to +85°C
TC126501ECT	5.0	5-Pin SOT-23	-40°C to +85°C
TC126331ECT	3.3	5-Pin SOT-23	-40°C to +85°C
TC126301ECT	3.0	5-Pin SOT-23	-40°C to +85°C

*Other output voltages are available. Please contact Microchip Technology Inc. for details.

Package Type

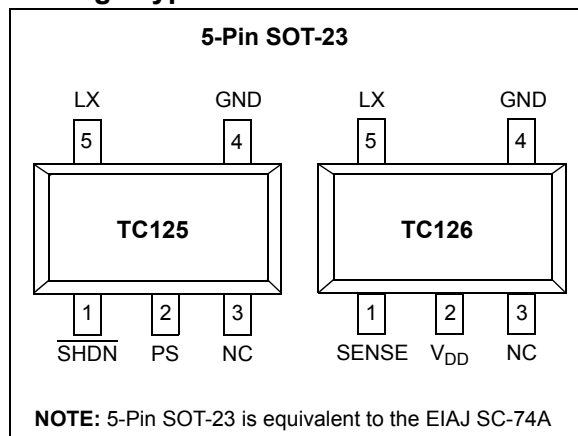

General Description:

The TC125/126 step-up (Boost) switching regulators furnish output currents to a maximum of 80 mA ($V_{IN} = 2V$, $V_{OUT} = 3V$) with typical efficiencies above 80%. These devices employ pulse frequency modulation (PFM) for minimum supply current at low loads. They are ideal for battery-operated applications powered from one or more cells. Maximum supply current is less than 70 μ A at full output load, and less than 5 μ A in standby ($V_{OUT} = 3V$). Both devices require only an external inductor, diode, and capacitor to implement a complete DC/DC regulator.

The TC126 has separate output voltage sensing and chip power inputs for greater application flexibility. The TC125 combines the output voltage sensing and chip power inputs onto a single package pin, but adds a power-saving Shutdown mode that suspends regulator operation and reduces supply current to less than 0.5 μ A when the shutdown control input (SHDN) is low.

The TC125/TC126 are available in a small 5-Pin SOT-23 package, occupy minimum board space and use small external components. The TC125 accepts input voltages from 2V to 10V. The TC126 accepts input voltages from 2.2V to 10V. Both the TC125 and TC126 have a start-up voltage of 0.9V at light load.

Typical Application

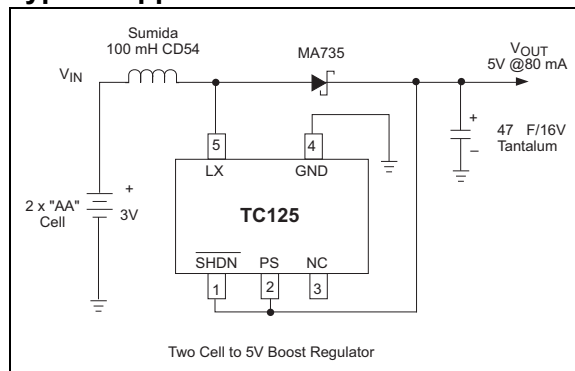

TC125/TC126

1.0 ELECTRICAL CHARACTERISTICS

Absolute Maximum Ratings*

Voltage on V _{DD} , SENSE/V _{DD} , LX, $\overline{\text{SHDN}}$ Pins	-0.3V to +12V
LX Sink Current	400 mA pk
Power Dissipation	150 mW
Operating Temperature Range	-40°C to +85°C
Storage Temperature Range	-40°C to +125°C

*Stresses above those listed under "Absolute Maximum Ratings" may cause permanent damage to the device. These are stress ratings only and functional operation of the device at these or any other conditions above those indicated in the operation sections of the specifications is not implied. Exposure to Absolute Maximum Rating conditions for extended periods may affect device reliability.

TC125/TC126 ELECTRICAL SPECIFICATIONS

Electrical Characteristics: V _{IN} = V _{OUT} × 0.6, T _A = 25°C, $\overline{\text{SHDN}}$ = V _{OUT} (TC125), unless otherwise noted.						
Symbol	Parameter	Min	Typ	Max	Units	Test Conditions
V _{OUT}	Output Voltage	V _R - 2.5%	V _R ± 0.5%	V _R + 2.5%	V	
V _{DD}	Operating Supply Voltage	0.70	—	10.0	V	Note 4
V _{START}	Start-Up Supply Voltage	—	0.80	0.90	V	I _{OUT} = 1mA
I _{DD}	Operating Supply Current				μA	(Note 2) V _{OUT} = 2V, I _{OUT} = 10 mA V _{OUT} = 3V, I _{OUT} = 30 mA V _{OUT} = 5V, I _{OUT} = 50 mA
I _{NL}	No Load Supply Current	—	5	9	μA	I _{OUT} = 0, V _{OUT} = 2V V _{OUT} = 3V V _{OUT} = 5V
		—	5	10		
		—	6	11		
I _{STBY}	Standby Supply Current	—	2	4	μA	V _{IN} = V _{OUT} + 0.5V, V _{IN} = 2V V _{IN} = 3V V _{IN} = 5V
		—	3	5		
		—	3	5		
I _{shdn}	Shutdown Supply Current	—	—	0.5	μA	$\overline{\text{SHDN}}$ = V _{IL} , (Note 2)
R _{LX(ON)}	LX Pin ON Resistance	—	10	14	W	V _{LX} = 0.4V, V _{OUT} = 2V V _{OUT} = 3V V _{OUT} = 5V (Note 2), (Note 3)
		—	6	8		
		—	3	5		
I _{LX}	LX Pin Leakage Current	—	—	1	μA	No external components, V _{OUT} = V _{LX} = 10V
D _{CYCLE}	Duty Cycle	70	75	80	%	Measured at LX pin (Note 2)
f _{MAX}	Maximum Oscillator Frequency	85	100	115	kHz	Note 2
V _{LX_LIM}	LX Pin Limit Voltage	0.7	—	1.1	V	Note 2
h	Efficiency	—	70	—	%	V _{OUT} = 2V V _{OUT} = 3V V _{OUT} = 5V
		—	80	—		
		—	85	—		
V _{IH}	$\overline{\text{SHDN}}$ Input Logic High	0.75	—	—	V	
V _{IL}	$\overline{\text{SHDN}}$ Input Logic Low	—	—	0.20	V	
I _{INh}	$\overline{\text{SHDN}}$ Input Current (High)	—	—	0.25	μA	
I _{INl}	$\overline{\text{SHDN}}$ Pin Input Current (Low)	-0.25	—	—	μA	

Note 1: V_R is the factory output voltage setting.

2: V_{IN} = V_{OUT} × 0.95.

3: V_{DD} input tied to SENSE input for TC126, as shown in Figure 3-2.

4: The V_{PS} input of the TC125 must be operated between 2.0V and 10.0V for spec compliance.
The V_{DD} input of the TC126 must be operated between 2.2V and 10.0V for spec compliance.

2.0 PIN DESCRIPTIONS

The descriptions of the pins are listed in Table 2-1.

TABLE 2-1: PIN FUNCTION TABLE

TC125 Pin No. (5-Pin SOT-23)	TC126 Pin No. (5-Pin SOT-23)	Symbol	Description
1	—	SHDN	Shutdown input. A logic low on this input suspends device operation and supply current is reduced to less than 0.5 μ A. The device resumes normal operation when SHDN is again brought high.
—	1	SENSE	Voltage sense input. This input provides feedback voltage sensing to the internal error amplifier. It must be connected to the output voltage node, preferably the single point in the system where tight voltage regulation is most beneficial.
2	—	PS	Power and voltage sense input. This dual function input provides both feedback voltage sensing and internal chip power. It should be connected to the regulator output. (See Figure 3-1).
—	2	V _{DD}	Power supply voltage input.
3	3	NC	Not connected.
4	4	GND	Ground terminal.
5	5	LX	Inductor switch output. LX is the drain of an internal N-channel switching transistor. This terminal drives the external inductor, which ultimately provides current to the load.

TC125/TC126

3.0 DETAILED DESCRIPTION

The TC125/126 are PFM step-up DC/DC regulators for use in systems operating from two or more cells or in low voltage, line powered applications. Because Pulse Frequency Modulation (PFM) is used, the TC125/126 switching frequency (and therefore supply current) is minimized at low output loads. This is especially important in battery operated applications (such as pagers) that operate in Standby mode most of the time. For example, a TC125/126 with a 3V output and no load will consume a maximum supply current of only 10 μ A versus a supply current of 40 μ A maximum when $I_{OUT} = 30$ mA. Both devices require only an external inductor, diode and capacitor to implement a complete DC/DC converter.

The TC125 is recommended for applications requiring Shutdown mode as a means of reducing system supply current. The TC125 is powered from the PS input, which must be connected to the regulated output as shown in Figure 3-1. PS also senses output voltage for closed-loop regulation. Start-up current is furnished through the inductor when input voltage is initially applied. This action starts the oscillator, causing the voltage at the PS input to rise, bootstrapping the regulator into full operation.

The TC126 (Figure 3-2) is recommended for all applications not requiring Shutdown mode. It has separate V_{DD} and SENSE inputs, allowing it to be powered from any source of 2.2V to 10V in the system. The V_{DD} input of the TC126 may be connected to the V_{IN} , V_{OUT} , or an external DC voltage. Lower values of V_{DD} result in lower supply current, but lower efficiency due to higher switch ON resistance. Higher V_{DD} values increase supply current, but drive the internal switching transistor harder (lowering $R_{DS(ON)}$), thereby increasing efficiency.

3.1 Low-Power Shutdown Mode

The TC125 enters a low-power Shutdown mode when \overline{SHDN} is brought low. While in shutdown, the oscillator is disabled and the internal switch is shut off. Normal regulator operation resumes when \overline{SHDN} is brought high. Because the TC125 uses an external diode, a leakage path between the input voltage and the output node (through the inductor and diode) exists while the regulator is in shutdown. Care must be taken in system design to assure the input supply is isolated from the load during shutdown.

3.2 Behavior When V_{IN} is Greater Than the Factory-Programmed OUT Setting

The TC125 and TC126 are designed to operate as step-up regulators only. As such, V_{IN} is assumed to always be less than the factory-programmed output voltage setting (V_R). Operating the TC125/126 with $V_{IN} > V_R$ causes regulating action to be suspended (and corresponding supply current reduction) until V_{IN} is again less than V_R . While regulating action is suspended, V_{IN} is connected to the output voltage node through the series combination of the inductor and Schottky diode. Again, care must be taken to add the appropriate isolation (MOSFET series switch or post LDO with shutdown) during system design if this V_{IN}/V_{OUT} leakage path is problematic.

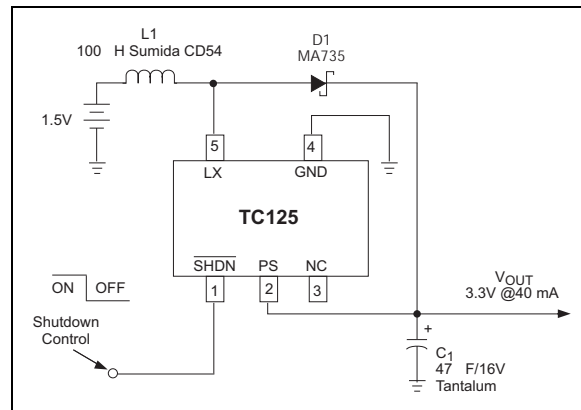

FIGURE 3-1: Typical TC125 Circuit

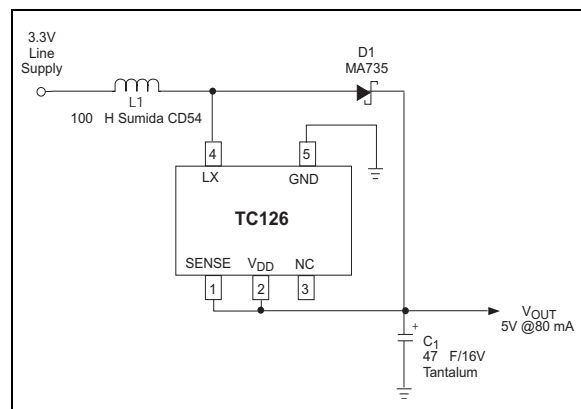

FIGURE 3-2: Typical TC126 Circuit

4.0 APPLICATIONS

4.1 Input Bypass Capacitors

Adding an input bypass capacitor reduces peak current transients drawn from the input supply and reduces the switching noise generated by the regulator. The source impedance of the input supply determines the size of the capacitor that should be used.

4.2 Inductor Selection

Selecting the proper inductor value is a trade-off between physical size and power conversion requirements. Lower value inductors cost less, but result in higher ripple current and core losses. They are also more prone to saturate since the coil current ramps to a higher value. Larger inductor values reduce both ripple current and core losses, but are larger in physical size and tend to increase the start-up time slightly. The recommended inductor value for use with the TC125/126 is 100 μ H. Inductors with a ferrite core (or equivalent) are recommended. For highest efficiency, use an inductor with a series resistance less than 20 $m\Omega$.

4.3 Internal Transistor Switch Current Limiting

The peak switch current is equal to the input voltage divided by the $R_{DS(ON)}$ of the internal switch. The internal transistor has absolute maximum current rating of 400 mA with a design limit of 350 mA. A built-in oscillator frequency doubling circuit guards against high switching currents. Should the voltage on the LX pin rise above 1.1V, max while the internal N-channel switch is ON, the oscillator frequency automatically doubles to minimize ON time. Although reduced, switch current still flows because the regulator remains in operation. Therefore, the LX input is not internally current limited and care must be taken never to exceed the 350 mA maximum limit. Failure to observe this will result in damage to the regulator.

4.4 Output Diode

For best results, use a Schottky diode such as the MA735, 1N5817, MBR0520L or equivalent. Connect the diode between the PS and LX pins (TC125) or SENSE and LX pins (TC126) as close to the IC as possible. (Do not use ordinary rectifier diodes since the higher threshold voltages reduce efficiency.)

4.5 Output Capacitor

The effective series resistance of the output capacitor directly affects the amplitude of the output voltage ripple. (The product of the peak inductor current and the ESR determines output ripple amplitude.) Therefore, a capacitor with the lowest possible ESR should be selected. Smaller capacitors are acceptable for light loads or in applications where ripple is not a concern. The Sprague 595D series of tantalum capacitors are among the smallest of all low ESR surface mount capacitors available. Table 4-1 lists suggested components and suppliers.

4.6 Board Layout Guidelines

As with all inductive switching regulators, the TC125/126 generate fast switching waveforms that radiate noise. Interconnecting lead lengths should be minimized to keep stray capacitance, trace resistance, and radiated noise as low as possible. In addition, the GND pin, input bypass capacitor, and output filter capacitor ground leads should be connected to a single point. The input capacitor should be placed as close to power and ground pins of the TC125/126 as possible.

TABLE 4-1: SUGGESTED COMPONENTS AND SUPPLIERS

Type	Inductors	Capacitors	Diodes
Surface Mount	Sumida CD54 Series CDR125 Series Coiltronics CTX Series Murata LQN6C Series	Matsuo 267 Series Murata GRM200 Series Sprague 595D Series Nichicon F93 Series	Nihon EC10 Series Matsushita MA735 Series
Through-Hole	Sumida RCH855 Series RCH110 Series Renco RL1284-12	Sanyo OS-CON Series Nichicon PL Series	ON Semiconductor 1N5817-1N5822

TC125/TC126

5.0 TYPICAL CHARACTERISTICS

(Unless Otherwise Specified, All Parts Are Measured At Temperature = 25°C)

Note: The graphs and tables provided following this note are a statistical summary based on a limited number of samples and are provided for informational purposes only. The performance characteristics listed herein are not tested or guaranteed. In some graphs or tables, the data presented may be outside the specified operating range (e.g., outside specified power supply range) and therefore outside the warranted range.

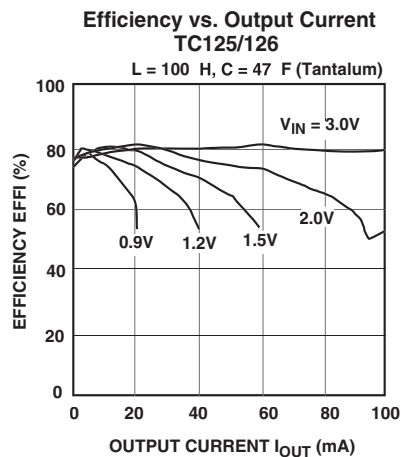
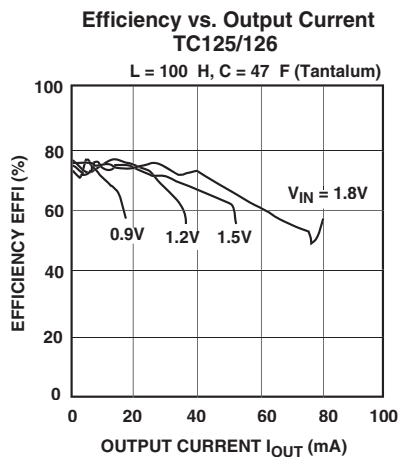
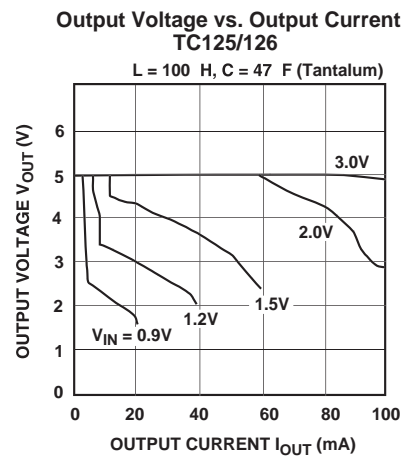
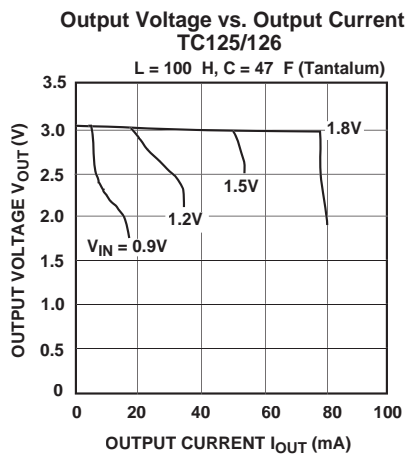

6.0 PACKAGING INFORMATION

6.1 Package Marking Information

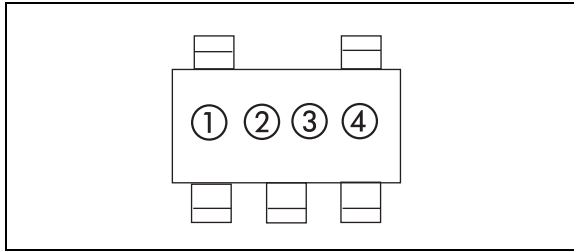

① represents product classification; TC125 = \bar{L}
TC126 = \bar{N}

② represents first integer of voltage

Symbol (100 kHz)	Voltage
1	1
2	2
3	3
4	4
5	5
6	6
7	7

③ represents first decimal of voltage

Symbol (100 kHz)	Voltage
0	.0
1	.1
2	.2
3	.3
4	.4
5	.5
6	.6
7	.7
8	.8
9	.9

④ represents production lot ID code

6.2 Taping Form

Component Taping Orientation for 5-Pin SOT-23 (EIAJ SC-74A) Devices

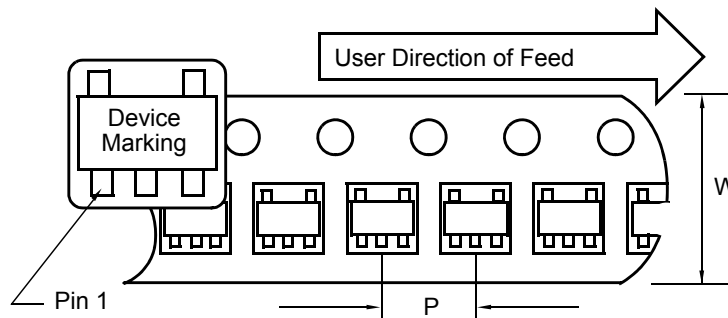

Standard Reel Component Orientation
TR Suffix Device
(Mark Right Side Up)

Carrier Tape, Number of Components Per Reel and Reel Size

Package	Carrier Width (W)	Pitch (P)	Part Per Full Reel	Reel Size
5-Pin SOT-23	8 mm	4 mm	3000	7 in

TC125/TC126

5-Lead Plastic Small Outline Transistor (OT or CT) [SOT-23]

Note: For the most current package drawings, please see the Microchip Packaging Specification located at <http://www.microchip.com/packaging>

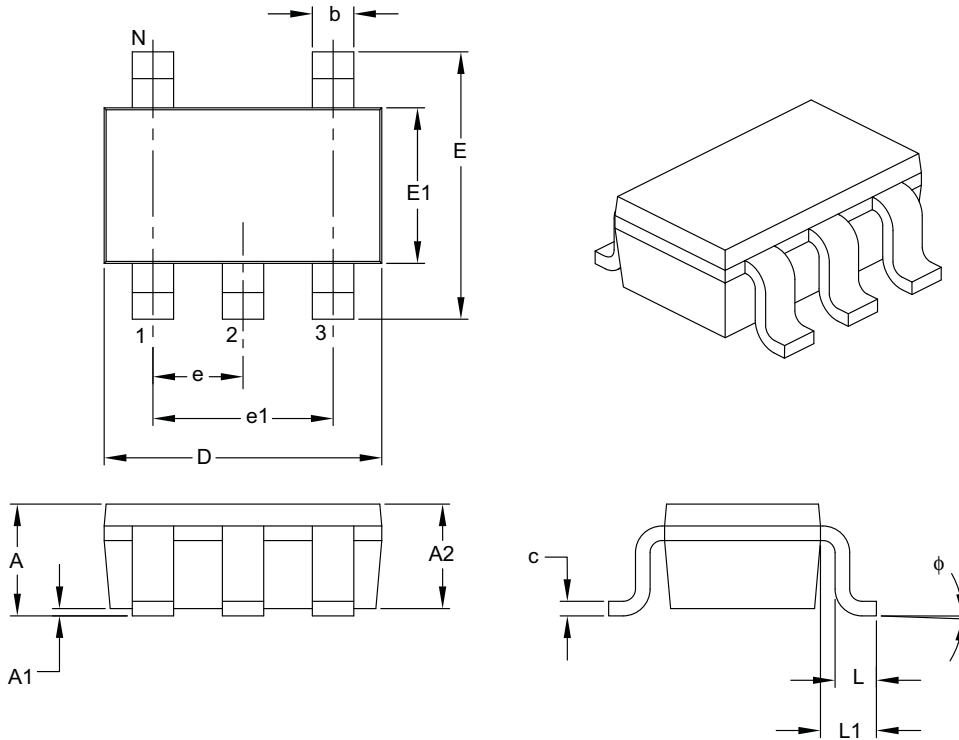

Dimension Limits	Units	MILLIMETERS		
		MIN	NOM	MAX
Number of Pins	N	5		
Lead Pitch	e	0.95 BSC		
Outside Lead Pitch	e1	1.90 BSC		
Overall Height	A	0.90	–	1.45
Molded Package Thickness	A2	0.89	–	1.30
Standoff	A1	0.00	–	0.15
Overall Width	E	2.20	–	3.20
Molded Package Width	E1	1.30	–	1.80
Overall Length	D	2.70	–	3.10
Foot Length	L	0.10	–	0.60
Footprint	L1	0.35	–	0.80
Foot Angle	ϕ	0°	–	30°
Lead Thickness	c	0.08	–	0.26
Lead Width	b	0.20	–	0.51

Notes:

- Dimensions D and E1 do not include mold flash or protrusions. Mold flash or protrusions shall not exceed 0.127 mm per side.
- Dimensioning and tolerancing per ASME Y14.5M.
BSC: Basic Dimension. Theoretically exact value shown without tolerances.

Microchip Technology Drawing C04-091B

Sales and Support

Data Sheets

Products supported by a preliminary Data Sheet may have an errata sheet describing minor operational differences and recommended workarounds. To determine if an errata sheet exists for a particular device, please contact one of the following:

1. Your local Microchip sales office
2. The Microchip Corporate Literature Center U.S. FAX: (480) 792-7277
3. The Microchip Worldwide Site (www.microchip.com)

Please specify which device, revision of silicon and Data Sheet (include Literature #) you are using.

New Customer Notification System

Register on our web site (www.microchip.com/cn) to receive the most current information on our products.

TC125/TC126

NOTES:

Note the following details of the code protection feature on Microchip devices:

- Microchip products meet the specification contained in their particular Microchip Data Sheet.
- Microchip believes that its family of products is one of the most secure families of its kind on the market today, when used in the intended manner and under normal conditions.
- There are dishonest and possibly illegal methods used to breach the code protection feature. All of these methods, to our knowledge, require using the Microchip products in a manner outside the operating specifications contained in Microchip's Data Sheets. Most likely, the person doing so is engaged in theft of intellectual property.
- Microchip is willing to work with the customer who is concerned about the integrity of their code.
- Neither Microchip nor any other semiconductor manufacturer can guarantee the security of their code. Code protection does not mean that we are guaranteeing the product as “unbreakable.”

Code protection is constantly evolving. We at Microchip are committed to continuously improving the code protection features of our products. Attempts to break Microchip's code protection feature may be a violation of the Digital Millennium Copyright Act. If such acts allow unauthorized access to your software or other copyrighted work, you may have a right to sue for relief under that Act.

Information contained in this publication regarding device applications and the like is provided only for your convenience and may be superseded by updates. It is your responsibility to ensure that your application meets with your specifications. MICROCHIP MAKES NO REPRESENTATIONS OR WARRANTIES OF ANY KIND WHETHER EXPRESS OR IMPLIED, WRITTEN OR ORAL, STATUTORY OR OTHERWISE, RELATED TO THE INFORMATION, INCLUDING BUT NOT LIMITED TO ITS CONDITION, QUALITY, PERFORMANCE, MERCHANTABILITY OR FITNESS FOR PURPOSE. Microchip disclaims all liability arising from this information and its use. Use of Microchip devices in life support and/or safety applications is entirely at the buyer's risk, and the buyer agrees to defend, indemnify and hold harmless Microchip from any and all damages, claims, suits, or expenses resulting from such use. No licenses are conveyed, implicitly or otherwise, under any Microchip intellectual property rights.

Trademarks

The Microchip name and logo, the Microchip logo, Accuron, dsPIC, KEELOQ, KEELOQ logo, microID, MPLAB, PIC, PICmicro, PICSTART, PRO MATE, PowerSmart, rPIC, and SmartShunt are registered trademarks of Microchip Technology Incorporated in the U.S.A. and other countries.

AmpLab, FilterLab, Linear Active Thermistor, Migratable Memory, MXDEV, MXLAB, PS logo, SEEVAL, SmartSensor and The Embedded Control Solutions Company are registered trademarks of Microchip Technology Incorporated in the U.S.A.

Analog-for-the-Digital Age, Application Maestro, CodeGuard, dsPICDEM, dsPICDEM.net, dsPICworks, ECAN, ECONOMONITOR, FanSense, FlexROM, fuzzyLAB, In-Circuit Serial Programming, ICSP, ICEPIC, Mindi, MiWi, MPASM, MPLAB Certified logo, MPLIB, MPLINK, PICkit, PICDEM, PICDEM.net, PICLAB, PICtail, PowerCal, PowerInfo, PowerMate, PowerTool, REAL ICE, rLAB, rfPICDEM, Select Mode, Smart Serial, SmartTel, Total Endurance, UNI/O, WiperLock and ZENA are trademarks of Microchip Technology Incorporated in the U.S.A. and other countries.

SQTP is a service mark of Microchip Technology Incorporated in the U.S.A.

All other trademarks mentioned herein are property of their respective companies.

© 2007, Microchip Technology Incorporated, Printed in the U.S.A., All Rights Reserved.

 Printed on recycled paper.

Microchip received ISO/TS-16949:2002 certification for its worldwide headquarters, design and wafer fabrication facilities in Chandler and Tempe, Arizona, Gresham, Oregon and Mountain View, California. The Company's quality system processes and procedures are for its PIC® MCUs and dsPIC® DSCs, KEELOQ® code hopping devices, Serial EEPROMs, microperipherals, nonvolatile memory and analog products. In addition, Microchip's quality system for the design and manufacture of development systems is ISO 9001:2000 certified.

QUALITY MANAGEMENT SYSTEM
CERTIFIED BY DNV
== ISO/TS 16949:2002 ==



WORLDWIDE SALES AND SERVICE

AMERICAS

Corporate Office

2355 West Chandler Blvd.
Chandler, AZ 85224-6199
Tel: 480-792-7200
Fax: 480-792-7277
Technical Support:
<http://support.microchip.com>
Web Address:
www.microchip.com

Atlanta

Duluth, GA
Tel: 678-957-9614
Fax: 678-957-1455

Boston

Westborough, MA
Tel: 774-760-0087
Fax: 774-760-0088

Chicago

Itasca, IL
Tel: 630-285-0071
Fax: 630-285-0075

Dallas

Addison, TX
Tel: 972-818-7423
Fax: 972-818-2924

Detroit

Farmington Hills, MI
Tel: 248-538-2250
Fax: 248-538-2260

Kokomo

Kokomo, IN
Tel: 765-864-8360
Fax: 765-864-8387

Los Angeles

Mission Viejo, CA
Tel: 949-462-9523
Fax: 949-462-9608

Santa Clara

Santa Clara, CA
Tel: 408-961-6444
Fax: 408-961-6445

Toronto

Mississauga, Ontario,
Canada
Tel: 905-673-0699
Fax: 905-673-6509

ASIA/PACIFIC

Asia Pacific Office

Suites 3707-14, 37th Floor
Tower 6, The Gateway
Harbour City, Kowloon
Hong Kong
Tel: 852-2401-1200
Fax: 852-2401-3431

Australia - Sydney

Tel: 61-2-9868-6733
Fax: 61-2-9868-6755

China - Beijing

Tel: 86-10-8528-2100
Fax: 86-10-8528-2104

China - Chengdu

Tel: 86-28-8665-5511
Fax: 86-28-8665-7889

China - Fuzhou

Tel: 86-591-8750-3506
Fax: 86-591-8750-3521

China - Hong Kong SAR

Tel: 852-2401-1200
Fax: 852-2401-3431

China - Qingdao

Tel: 86-532-8502-7355
Fax: 86-532-8502-7205

China - Shanghai

Tel: 86-21-5407-5533
Fax: 86-21-5407-5066

China - Shenyang

Tel: 86-24-2334-2829
Fax: 86-24-2334-2393

China - Shenzhen

Tel: 86-755-8203-2660
Fax: 86-755-8203-1760

China - Shunde

Tel: 86-757-2839-5507
Fax: 86-757-2839-5571

China - Wuhan

Tel: 86-27-5980-5300
Fax: 86-27-5980-5118

China - Xian

Tel: 86-29-8833-7250
Fax: 86-29-8833-7256

ASIA/PACIFIC

India - Bangalore

Tel: 91-80-4182-8400
Fax: 91-80-4182-8422

India - New Delhi

Tel: 91-11-4160-8631
Fax: 91-11-4160-8632

India - Pune

Tel: 91-20-2566-1512
Fax: 91-20-2566-1513

Japan - Yokohama

Tel: 81-45-471-6166
Fax: 81-45-471-6122

Korea - Gumi

Tel: 82-54-473-4301
Fax: 82-54-473-4302

Korea - Seoul

Tel: 82-2-554-7200
Fax: 82-2-558-5932 or
82-2-558-5934

Malaysia - Penang

Tel: 60-4-646-8870
Fax: 60-4-646-5086

Philippines - Manila

Tel: 63-2-634-9065
Fax: 63-2-634-9069

Singapore

Tel: 65-6334-8870
Fax: 65-6334-8850

Taiwan - Hsin Chu

Tel: 886-3-572-9526
Fax: 886-3-572-6459

Taiwan - Kaohsiung

Tel: 886-7-536-4818
Fax: 886-7-536-4803

Taiwan - Taipei

Tel: 886-2-2500-6610
Fax: 886-2-2508-0102

Thailand - Bangkok

Tel: 66-2-694-1351
Fax: 66-2-694-1350

EUROPE

Austria - Wels

Tel: 43-7242-2244-39
Fax: 43-7242-2244-393

Denmark - Copenhagen

Tel: 45-4450-2828
Fax: 45-4485-2829

France - Paris

Tel: 33-1-69-53-63-20
Fax: 33-1-69-30-90-79

Germany - Munich

Tel: 49-89-627-144-0
Fax: 49-89-627-144-44

Italy - Milan

Tel: 39-0331-742611
Fax: 39-0331-466781

Netherlands - Drunen

Tel: 31-416-690399
Fax: 31-416-690340

Spain - Madrid

Tel: 34-91-708-08-90
Fax: 34-91-708-08-91

UK - Wokingham

Tel: 44-118-921-5869
Fax: 44-118-921-5820