

PFM/PWM Step-Down DC/DC Controller

Features

- 57 μ A (Typ) Supply Current
- 1A Output Current
- 0.5 μ A Shutdown Mode
- 300kHz Switching Frequency for Small Inductor Size
- Programmable Soft-Start
- 92% Typical Efficiency
- Small Package: 5-Pin SOT-23A

Applications

- Palmtops
- Battery-Operated Systems
- Portable Instruments
- Positive LCD Bias Generators
- Portable Communicators
- Hand-Held Scanners
- 5V to 3V Down Converters

Device Selection Table

Part Number	Output Voltage (V)*	Package	Osc. Freq. (kHz)	Operating Temp. Range
TC105503ECT	5.0	5-Pin SOT-23A	300	-40°C to +85°C
TC105333ECT	3.3	5-Pin SOT-23A	300	-40°C to +85°C
TC105303ECT	3.0	5-Pin SOT-23A	300	-40°C to +85°C

*Other output voltages are available. Please contact Microchip Technology Inc. for details.

Functional Block Diagram

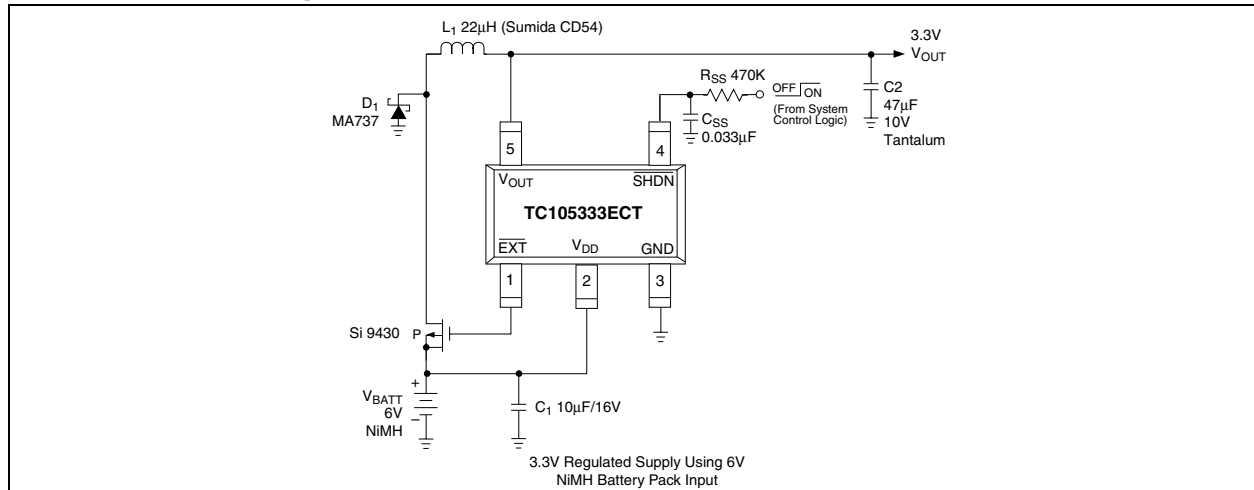

Package Type

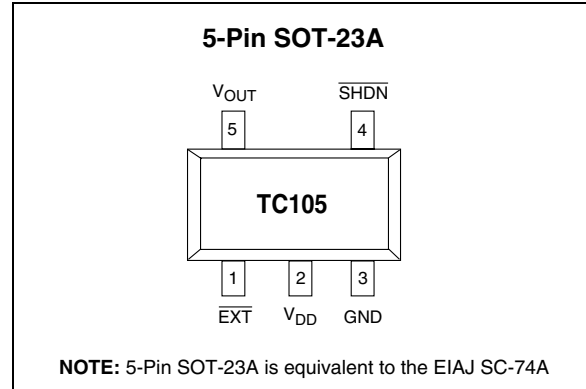

General Description

The TC105 is a step-down (Buck) switching controller that furnishes output currents of up to 1A (max) while delivering a typical efficiency of 92%. The TC105 normally operates in pulse width modulation mode (PWM), but automatically switches to pulse frequency modulation (PFM) at low output loads for greater efficiency. Oscillator frequency is 300kHz, allowing use of small (22 μ H) inductors. Supply current draw is only 102 μ A (max), and is reduced to less than 0.5 μ A when the SHDN input is brought low. Regulator operation is suspended during shutdown. The TC105 accepts a maximum input voltage of 10V.

The TC105 is available in a small 5-Pin SOT-23A package, occupies minimum board space and is ideal for a wide range of applications.

TC105

1.0 ELECTRICAL CHARACTERISTICS

Absolute Maximum Ratings*

Voltage on V_{DD}-0.3V to +12V
 \overline{EXT} Output Current ± 100 mA
 Voltage on V_{OUT} , \overline{EXT} ,
 \overline{SHDN} Pins-0.3V to $V_{DD} + 0.3$ V
 Power Dissipation..... 150mW
 Operating Temperature Range..... -40°C to +85°C
 Storage Temperature Range -40°C to +125°C

*Stresses above those listed under "Absolute Maximum Ratings" may cause permanent damage to the device. These are stress ratings only and functional operation of the device at these or any other conditions above those indicated in the operation sections of the specifications is not implied. Exposure to Absolute Maximum Rating conditions for extended periods may affect device reliability.

TC105 ELECTRICAL SPECIFICATIONS

Electrical Characteristics: Note 1, $f_{OSC} = 300$ kHz; $T_A = 25^\circ\text{C}$, unless otherwise noted.						
Symbol	Parameter	Min	Typ	Max	Units	Test Conditions
V_{DD}	Operating Supply Voltage	2.2	—	10.0	V	
V_{DDMIN}	Minimum Input Voltage	0.9	—	2.2	V	$\overline{EXT} = \text{High}$; No external components; $V_{OUT} = 0\text{V}$, $\overline{SHDN} = V_{IN}$
I_{DD}	Operating Supply Current	—	57 67	102 122	μA	No external components; $V_R = 3.0\text{V}$, 3.3V $V_{OUT} = 0\text{V}$, $\overline{SHDN} = V_{IN}$ $V_R = 5.0\text{V}$
I_{STBY}	Standby Supply Current	—	15 16	27 29	μA	No external components; $V_R = 3.0\text{V}$, 3.3V $V_{OUT} = \overline{SHDN} = V_{IN}$ $V_R = 5.0\text{V}$
I_{SHDN}	Shutdown Supply Current	—	—	0.5	μA	$\overline{SHDN} = \text{GND}$
f_{OSC}	Oscillator Frequency	255	300	345	kHz	$V_{IN} = V_{OUT} + 0.3\text{V}$
V_{OUT}	Output Voltage	$V_R \times 0.975$	V_R	$V_R \times 1.025$		Note 2
DTYMAX	Maximum Duty Cycle (PWM Mode)	100	—	—	%	
DTYPFM	Duty Cycle (PFM Mode)	15	25	35	%	$I_{OUT} = 0\text{mA}$
V_{IH}	\overline{SHDN} Input Logic High	0.65	—	—	V	$V_{OUT} = 0\text{V}$, No external components
V_{IL}	\overline{SHDN} Input Logic Low	—	—	0.20	V	$V_{OUT} = 0\text{V}$, No external components
REXTH	\overline{EXT} ON Resistance to V_{DD}	—	17 16 12	24 22 17	Ω	No external components; $V_R = 3.0\text{V}$ $V_R = 3.3\text{V}$ $V_R = 5.0\text{V}$ $V_{OUT} = \overline{SHDN} = V_{IN}$, $V_{EXT} = (V_{IN} - 0.4\text{V})$
REXTL	\overline{EXT} ON Resistance to GND	—	15 14 10	20 19 14	Ω	No external components; $V_R = 3.0\text{V}$ $V_R = 3.3\text{V}$ $V_R = 5.0\text{V}$ $V_{OUT} = 0\text{V}$, $\overline{SHDN} = V_{IN}$, $V_{EXT} = 0.4\text{V}$
η	Efficiency	—	92	—	%	

Note 1: $V_R = 3.0\text{V}$, $V_{IN} = 4.5\text{V}$, $I_{OUT} = 200\text{mA}$
 $V_R = 3.3\text{V}$, $V_{IN} = 5.0\text{V}$, $I_{OUT} = 220\text{mA}$
 $V_R = 5.0\text{V}$, $V_{IN} = 7.5\text{V}$, $I_{OUT} = 320\text{mA}$
2: V_R is the factory output voltage setting.

2.0 PIN DESCRIPTIONS

The descriptions of the pins are listed in Table 2-1.

TABLE 2-1: PIN FUNCTION TABLE

Pin No. (5-Pin SOT-23A)	Symbol	Description
1	$\overline{\text{EXT}}$	Switch transistor control output. This terminal connects to the gate of an external P-channel MOSFET (or to the base of an external PNP transistor through a current limiting resistor).
2	V_{DD}	Power supply voltage input.
3	GND	Ground terminal.
4	$\overline{\text{SHDN}}$	Shutdown input (active low). The device enters a low power shutdown state when this input is brought low. During shutdown, regulator action is suspended, and supply current is reduced to less than 0.5 μA . The device resumes normal operation when $\overline{\text{SHDN}}$ is again brought high.
5	V_{OUT}	Voltage sense input. This input senses output voltage for regulation and must be connected to the output voltage node as shown in the application schematic in this data sheet.

3.0 DETAILED DESCRIPTION

The TC105 is a PFM/PWM step-down DC/DC controller for use in systems operating from two or more cells, or in line-powered applications. It uses PWM as the primary modulation scheme, but automatically converts to PFM at output duty cycles less than approximately 10%. The conversion to PFM provides reduced supply current, and therefore higher operating efficiency at low loads. The TC105 uses an external switching transistor, allowing construction of switching regulators with output currents of up to 1A.

The TC105 consumes only 102 μ A, max, of supply current when $V_{IN} = 5V$ and $V_{OUT} = 3.3V$, and can be placed in a 0.5 μ A shutdown mode by bringing the shutdown input (\overline{SHDN}) low. The regulator remains disabled while in shutdown mode, and output voltage discharges to zero through the load. Normal operation resumes when \overline{SHDN} is brought high. Other features include a built-in undervoltage lockout (UVLO) and externally programmable soft start time.

3.1 Low Power Shutdown Mode

The TC105 enters a low power shutdown mode when \overline{SHDN} is brought low. While in shutdown, the oscillator is disabled and the output switch is shut off. Normal regulator operation resumes when \overline{SHDN} is again brought high. \overline{SHDN} may be tied to the input supply if not used.

3.2 Soft Start

Soft start allows the output voltage to gradually ramp from 0 to rated output value during start-up. This action minimizes (or eliminates) overshoot, and in general, reduces stress on circuit components. Figure 4-1 shows the circuit required to implement soft start (values of 470K and 0.033 μ F for R_{SS} and C_{SS} respectively, are adequate for most applications).

3.3 Undervoltage Lockout (UVLO)

The TC105 is disabled when V_{IN} is below the undervoltage lockout threshold. This threshold is equal to the guaranteed minimum operating voltage for the TC105 (i.e., 2.2V). When UVLO is active, the TC105 is completely disabled.

3.4 Input Bypass Capacitors

Using an input bypass capacitor reduces peak current transients drawn from the input supply and reduces the switching noise generated by the regulator. The source impedance of the input supply determines the size of the capacitor that should be used.

3.5 Output Capacitor

The effective series resistance of the output capacitor directly affects the amplitude of the output voltage ripple. (The product of the peak inductor current and the ESR determines output ripple amplitude.) Therefore, a capacitor with the lowest possible ESR should be selected. Smaller capacitors are acceptable for light loads or in applications where ripple is not a concern. The Sprague 595D series of tantalum capacitors are among the smallest of all low ESR surface mount capacitors available. Table 4-1 lists suggested components and suppliers.

3.6 Inductor Selection

Selecting the proper inductor value is a trade-off between physical size and power conversion requirements. Lower value inductors cost less, but result in higher ripple current and core losses. They are also more prone to saturate since the coil current ramps faster and could overshoot the desired peak value. This not only reduces efficiency, but could also cause the current rating of the external components to be exceeded. Larger inductor values reduce both ripple current and core losses, but are larger in physical size and tend to increase the start-up time slightly.

A 22 μ H inductor is recommended as the best overall compromise. For highest efficiency, use inductors with a low DC resistance (less than 20 m Ω). To minimize radiated noise, consider using a toroid, pot core or shielded-bobbin inductor.

3.7 Output Diode

The high operating frequency of the TC105 requires a high-speed diode. Schottky diodes such as the MA737 or 1N5817 through 1N5823 (and the equivalent surface mount versions) are recommended. Select a diode whose average current rating is greater than the peak inductor current and whose voltage rating is higher than V_{DDMAX} .

3.8 External Switching Transistor Selection

$\overline{\text{EXT}}$ is a complementary output with a maximum ON resistance of 22Ω to V_{DD} when high and 19Ω to ground when low. It is designed to directly drive a P-channel MOSFET or a PNP bipolar transistor through a base current limiting resistor (Figure 4-2). A PNP transistor is recommended in applications where V_{IN} is less than 2.5V. Otherwise, a P-channel MOSFET is preferred as it affords the highest efficiency because it does not draw any gate drive current. However, P-channel MOSFETs are typically more expensive than bipolar transistors.

P-channel MOSFET selection is determined mainly by the on-resistance, gate-source threshold, and gate charge requirements. Also, the drain-to-source and gate-to-source breakdown voltage ratings must be greater than V_{DDMAX} . The total gate charge specification should be less than 100nC for best efficiency. The MOSFET must be capable of handling the required peak inductor current, and should have a very low on-resistance at that current. For example, an Si9430 MOSFET has a drain-to-source rating of -20V, and a typical on-resistance $r_{\text{DS(on)}}$ of 0.07Ω at 2A, with $V_{\text{GS}} = -4.5\text{V}$. Table 4-1 lists suppliers of external components recommended for use with the TC105.

3.8.1 BOARD LAYOUT GUIDELINES

As with all inductive switching regulators, the TC105 generates fast switching waveforms, which radiate noise. Interconnecting lead lengths should be minimized to keep stray capacitance, trace resistance and radiated noise as low as possible. In addition, the GND pin, input bypass capacitor and output filter capacitor ground leads should be connected to a single point. The input capacitor should be placed as close to power and ground pins of the TC105 as possible. The length of the $\overline{\text{EXT}}$ trace must also be kept as short as possible.

TC105

4.0 APPLICATIONS

4.1 Circuit Examples

Figure 4-3 shows a TC105 using a PNP switching transistor (Zetex FZT749) that has an h_{FE} of 180 and V_{CESAT} of 100 mV at $I_C = 1A$. Other high beta transistors can be used, but the values of R_B and C_B may need adjustment if h_{FE} is significantly different from that of the FZT749.

The circuit of Figure 4-4 utilizes a P-channel MOSFET switching transistor (Silconix Si9430). This transistor is a member of the Littlefoot™ family of small outline MOSFETs.

FIGURE 4-1: SOFT START CIRCUIT

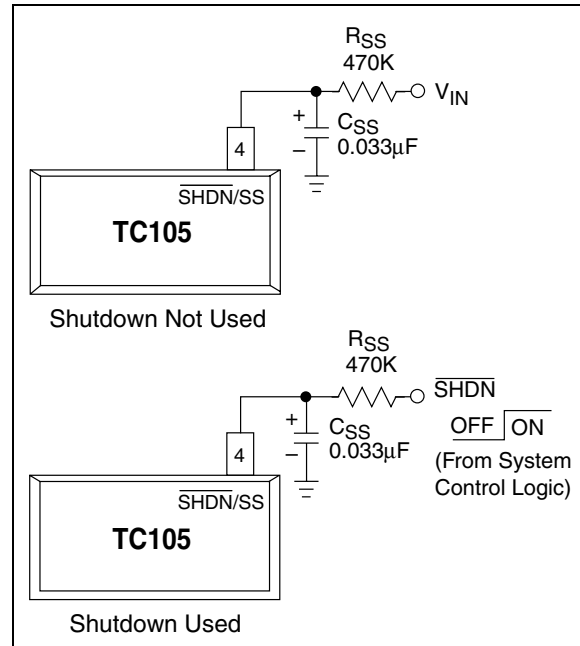

FIGURE 4-2: EXTERNAL TRANSISTOR CONNECTION

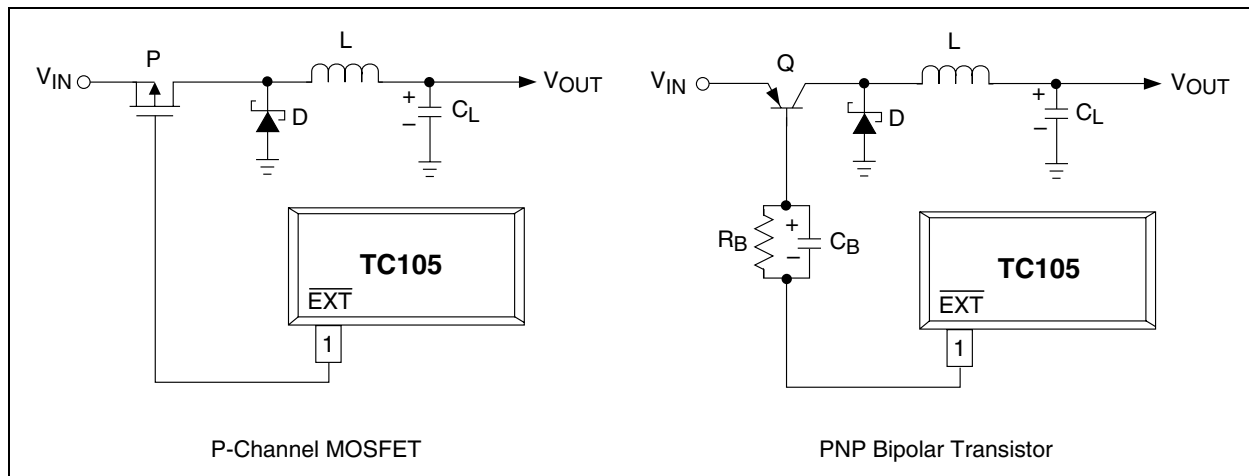

FIGURE 4-3: REGULATOR USING PNP TRANSISTOR

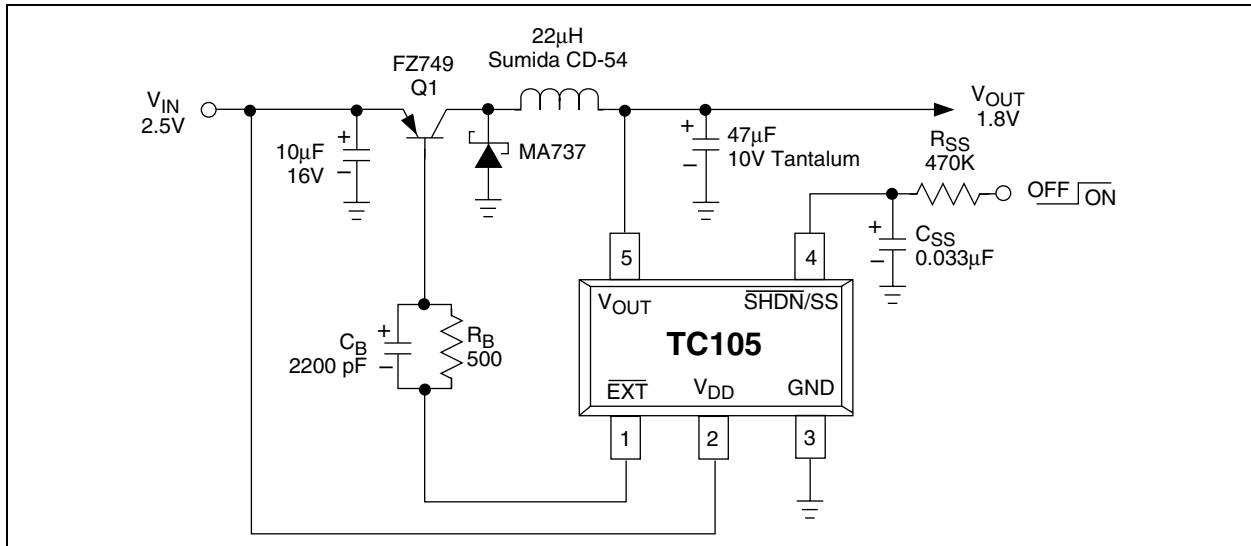

FIGURE 4-4: REGULATOR USING P-CHANNEL MOSFET

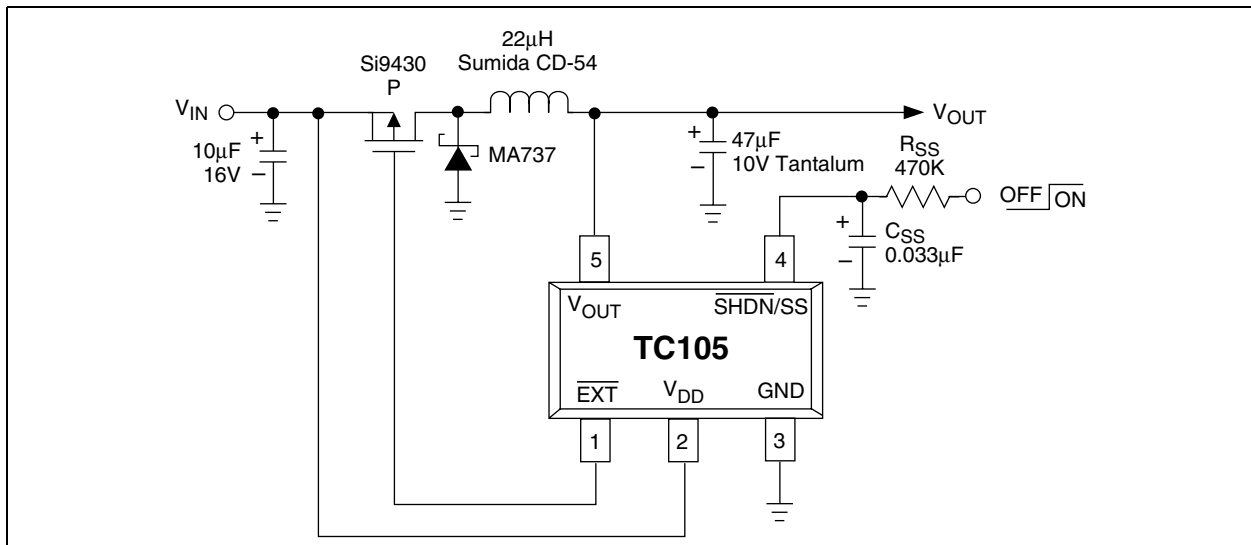

TABLE 4-1: SUGGESTED COMPONENTS AND SUPPLIERS

Type	Inductors	Capacitors	Diodes	Transistors
Surface Mount	Sumida CD54 Series CDRH Series Coilcraft DO Series	AVX TPS Series Sprague 595D Series	ON Semiconductor MBRS340T3 Nihon NSQ Series Matsushita MA737	Silconix Little Foot MOSFET Series Zetex FZT749 PNP Bipolar Transistor Toshiba 2SA1213 PNP Transistor
Miniature Through-Hole	Sumida RCH Series	Sanyo OS-CON Series	IRC OAR Series	
Standard Through-Hole	Coilcraft PCH Series Coiltronics CTX Series	Nichicon PL Series United Chemi-Con LXF Series		ON Semiconductor TMOS Power MOSFETs (i.e., MTP30P06V)

TC105

5.0 PACKAGING INFORMATION

5.1 Package Marking Information

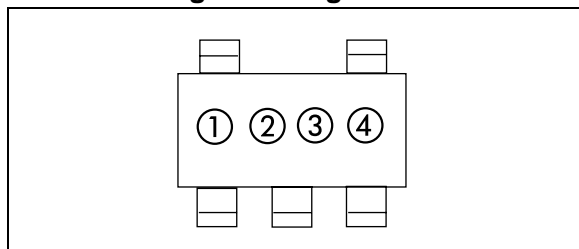

① represents product classification; TC105 = M

② represents first integer of voltage

Symbol (300kHz)	Voltage
<u>1</u>	1.
<u>2</u>	2.
<u>3</u>	3.
<u>4</u>	4.
<u>5</u>	5.
<u>6</u>	6.

③ represents first decimal of voltage

Symbol (300kHz)	Voltage
A	.0
B	.1
C	.2
D	.3
E	.4
F	.5
H	.6
K	.7
L	.8
M	.9

④ represents production lot ID code

5.2 Taping Form

Component Taping Orientation for 5-Pin SOT-23A (EIAJ SC-74A) Devices

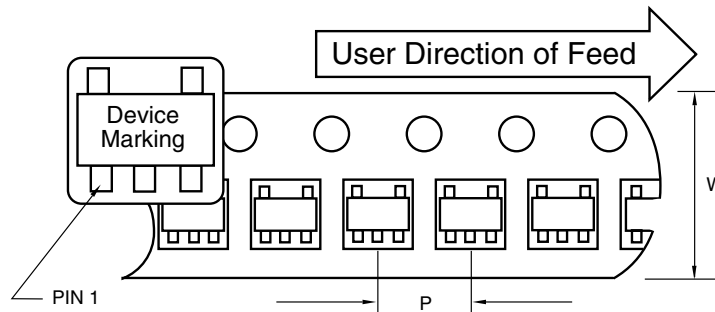

Standard Reel Component Orientation
 TR Suffix Device
 (Mark Right Side Up)

Carrier Tape, Number of Components Per Reel and Reel Size

Package	Carrier Width (W)	Pitch (P)	Part Per Full Reel	Reel Size
5-Pin SOT-23A	8 mm	4 mm	3000	7 in

5.3 Package Dimensions

SOT-23A-5

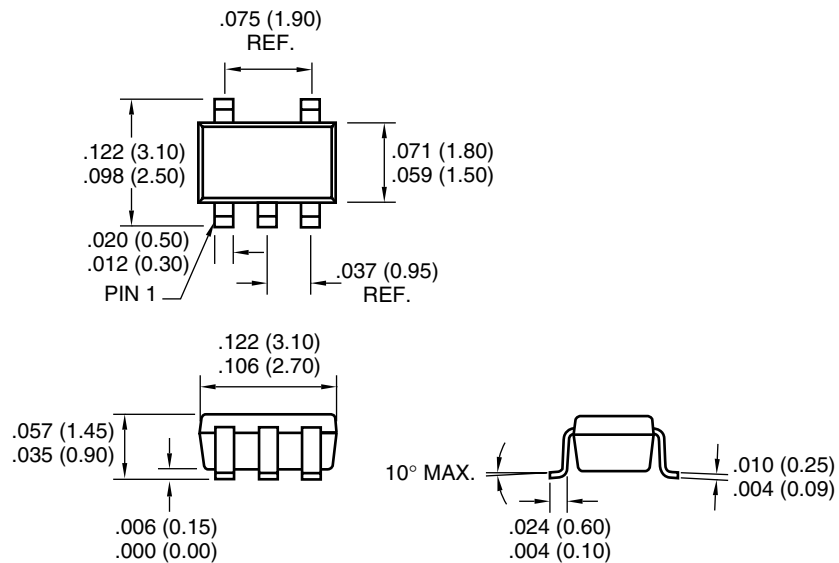

Dimensions: inches (mm)

TC105

NOTES:

Sales and Support

Data Sheets

Products supported by a preliminary Data Sheet may have an errata sheet describing minor operational differences and recommended workarounds. To determine if an errata sheet exists for a particular device, please contact one of the following:

1. Your local Microchip sales office
2. The Microchip Corporate Literature Center U.S. FAX: (480) 792-7277
3. The Microchip Worldwide Site (www.microchip.com)

Please specify which device, revision of silicon and Data Sheet (include Literature #) you are using.

New Customer Notification System

Register on our web site (www.microchip.com/cn) to receive the most current information on our products.

TC105

NOTES:

Information contained in this publication regarding device applications and the like is intended through suggestion only and may be superseded by updates. It is your responsibility to ensure that your application meets with your specifications. No representation or warranty is given and no liability is assumed by Microchip Technology Incorporated with respect to the accuracy or use of such information, or infringement of patents or other intellectual property rights arising from such use or otherwise. Use of Microchip's products as critical components in life support systems is not authorized except with express written approval by Microchip. No licenses are conveyed, implicitly or otherwise, under any intellectual property rights.

Trademarks

The Microchip name and logo, the Microchip logo, FilterLab, KEELOQ, microID, MPLAB, PIC, PICmicro, PICMASTER, PICSTART, PRO MATE, SEEVAL and The Embedded Control Solutions Company are registered trademarks of Microchip Technology Incorporated in the U.S.A. and other countries.

dsPIC, ECONOMONITOR, FanSense, FlexROM, fuzzyLAB, In-Circuit Serial Programming, ICSP, ICEPIC, microPort, Migratable Memory, MPASM, MPLIB, MPLINK, MPSIM, MXDEV, MXLAB, PICC, PICDEM, PICDEM.net, rPIC, Select Mode and Total Endurance are trademarks of Microchip Technology Incorporated in the U.S.A.

Serialized Quick Turn Programming (SQTP) is a service mark of Microchip Technology Incorporated in the U.S.A.

All other trademarks mentioned herein are property of their respective companies.

© 2002, Microchip Technology Incorporated, Printed in the U.S.A., All Rights Reserved.

 Printed on recycled paper.

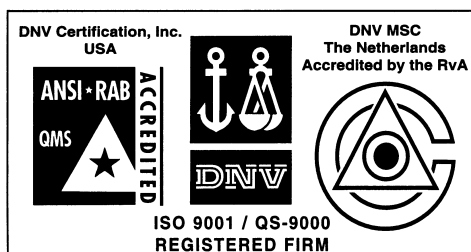

Microchip received QS-9000 quality system certification for its worldwide headquarters, design and wafer fabrication facilities in Chandler and Tempe, Arizona in July 1999 and Mountain View, California in March 2002. The Company's quality system processes and procedures are QS-9000 compliant for its PICmicro® 8-bit MCUs, KEELOQ® code hopping devices, Serial EEPROMs, microperipherals, non-volatile memory and analog products. In addition, Microchip's quality system for the design and manufacture of development systems is ISO 9001 certified.



MICROCHIP

WORLDWIDE SALES AND SERVICE

AMERICAS

Corporate Office

2355 West Chandler Blvd.
Chandler, AZ 85224-6199
Tel: 480-792-7200 Fax: 480-792-7277
Technical Support: 480-792-7627
Web Address: <http://www.microchip.com>

Rocky Mountain

2355 West Chandler Blvd.
Chandler, AZ 85224-6199
Tel: 480-792-7966 Fax: 480-792-7456

Atlanta

500 Sugar Mill Road, Suite 200B
Atlanta, GA 30350
Tel: 770-640-0034 Fax: 770-640-0307

Boston

2 Lan Drive, Suite 120
Westford, MA 01886
Tel: 978-692-3848 Fax: 978-692-3821

Chicago

333 Pierce Road, Suite 180
Itasca, IL 60143
Tel: 630-285-0071 Fax: 630-285-0075

Dallas

4570 Westgrove Drive, Suite 160
Addison, TX 75001
Tel: 972-818-7423 Fax: 972-818-2924

Detroit

Tri-Atria Office Building
32255 Northwestern Highway, Suite 190
Farmington Hills, MI 48334
Tel: 248-538-2250 Fax: 248-538-2260

Kokomo

2767 S. Albright Road
Kokomo, Indiana 46902
Tel: 765-864-8360 Fax: 765-864-8387

Los Angeles

18201 Von Karman, Suite 1090
Irvine, CA 92612
Tel: 949-263-1888 Fax: 949-263-1338

New York

150 Motor Parkway, Suite 202
Hauppauge, NY 11788
Tel: 631-273-5305 Fax: 631-273-5335

San Jose

Microchip Technology Inc.
2107 North First Street, Suite 590
San Jose, CA 95131
Tel: 408-436-7950 Fax: 408-436-7955

Toronto

6285 Northam Drive, Suite 108
Mississauga, Ontario L4V 1X5, Canada
Tel: 905-673-0699 Fax: 905-673-6509

ASIA/PACIFIC

Australia

Microchip Technology Australia Pty Ltd
Suite 22, 41 Rawson Street
Epping 2121, NSW
Australia
Tel: 61-2-9868-6733 Fax: 61-2-9868-6755

China - Beijing

Microchip Technology Consulting (Shanghai)
Co., Ltd., Beijing Liaison Office
Unit 915
Bei Hai Wan Tai Bldg.
No. 6 Chaoyangmen Beidajie
Beijing, 100027, No. China
Tel: 86-10-85282100 Fax: 86-10-85282104

China - Chengdu

Microchip Technology Consulting (Shanghai)
Co., Ltd., Chengdu Liaison Office
Rm. 2401, 24th Floor,
Ming Xing Financial Tower
No. 88 TIDU Street
Chengdu 610016, China
Tel: 86-28-86766200 Fax: 86-28-86766599

China - Fuzhou

Microchip Technology Consulting (Shanghai)
Co., Ltd., Fuzhou Liaison Office
Unit 28F, World Trade Plaza
No. 71 Wusi Road
Fuzhou 350001, China
Tel: 86-591-7503506 Fax: 86-591-7503521

China - Shanghai

Microchip Technology Consulting (Shanghai)
Co., Ltd.
Room 701, Bldg. B
Far East International Plaza
No. 317 Xian Xia Road
Shanghai, 200051
Tel: 86-21-6275-5700 Fax: 86-21-6275-5060

China - Shenzhen

Microchip Technology Consulting (Shanghai)
Co., Ltd., Shenzhen Liaison Office
Rm. 1315, 13/F, Shenzhen Kerry Centre,
Renminnan Lu
Shenzhen 518001, China
Tel: 86-755-2350361 Fax: 86-755-2366086

China - Hong Kong SAR

Microchip Technology Hongkong Ltd.
Unit 901-6, Tower 2, Metroplaza
223 Hing Fong Road
Kwai Fong, N.T., Hong Kong
Tel: 852-2401-1200 Fax: 852-2401-3431

India

Microchip Technology Inc.
India Liaison Office
Divyasree Chambers
1 Floor, Wing A (A3/A4)
No. 11, O'Shaugnessey Road
Bangalore, 560 025, India
Tel: 91-80-2290061 Fax: 91-80-2290062

Japan

Microchip Technology Japan K.K.
Benex S-1 6F
3-18-20, Shinyokohama
Kohoku-Ku, Yokohama-shi
Kanagawa, 222-0033, Japan
Tel: 81-45-471-6166 Fax: 81-45-471-6122

Korea

Microchip Technology Korea
168-1, Youngbo Bldg. 3 Floor
Samsung-Dong, Kangnam-Ku
Seoul, Korea 135-882
Tel: 82-2-554-7200 Fax: 82-2-558-5934

Singapore

Microchip Technology Singapore Pte Ltd.
200 Middle Road
#07-02 Prime Centre
Singapore, 188980
Tel: 65-6334-8870 Fax: 65-6334-8850

Taiwan

Microchip Technology Taiwan
11F-3, No. 207
Tung Hua North Road
Taipei, 105, Taiwan
Tel: 886-2-2717-7175 Fax: 886-2-2545-0139

EUROPE

Denmark

Microchip Technology Nordic ApS
Regus Business Centre
Lautrup høj 1-3
Ballerup DK-2750 Denmark
Tel: 45 4420 9895 Fax: 45 4420 9910

France

Microchip Technology SARL
Parc d'Activite du Moulin de Massy
43 Rue du Saule Trapu
Batiment A - 1er Etage
91300 Massy, France
Tel: 33-1-69-53-63-20 Fax: 33-1-69-30-90-79

Germany

Microchip Technology GmbH
Gustav-Heinemann Ring 125
D-81739 Munich, Germany
Tel: 49-89-627-144 0 Fax: 49-89-627-144-44

Italy

Microchip Technology SRL
Centro Direzionale Colleoni
Palazzo Taurus 1 V. Le Colleoni 1
20041 Agrate Brianza
Milan, Italy
Tel: 39-039-65791-1 Fax: 39-039-6899883

United Kingdom

Microchip Ltd.
505 Eskdale Road
Winnersh Triangle
Wokingham
Berkshire, England RG41 5TU
Tel: 44 118 921 5869 Fax: 44-118 921-5820

05/01/02