

Linear Building Block – Single Operational Amplifiers in SOT Packages

Features

- Tiny SOT-23A Package
- Optimized for Single Supply Operation
- Ultra Low Input Bias Current: Less than 100pA
- Low Quiescent Current: 6 μ A (Typ.)
Shutdown Mode: 0.05 μ A (Typ.) (TC1035)
- Shutdown Mode (TC1035)
- Rail-to-Rail Inputs and Outputs

Applications

- Power Management Circuits
- Battery Operated Equipment
- Consumer Products

Device Selection Table

Part Number	Package	Temperature Range
TC1034ECT	5-Pin SOT-23A	-40°C to +85°C
TC1035ECH	6-Pin SOT-23A	-40°C to +85°C

Package Types

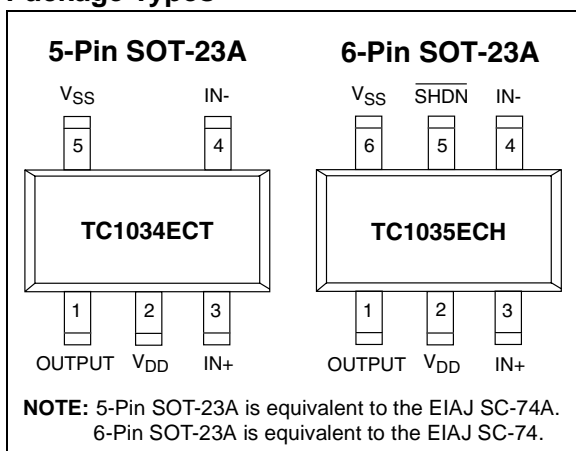

General Description

The TC1034/TC1035 are single CMOS operational amplifiers for low power applications.

They have a typical operating supply current of 6 μ A, which is constant over the supply voltage range of 1.8V to 5.5V. The Op Amp has a rail-to-rail input and output which allows operation at low supply voltages with large input and output signal swings.

An active low shutdown input, $\overline{\text{SHDN}}$, is available on the TC1035 and disables the op amp, placing its output in a high-impedance state. The TC1035 draws less than 0.1 μ A when the shutdown mode is active.

Packaged in a 5-Pin SOT-23A (TC1034) or 6-Pin SOT-23A (TC1035), these single operational amplifiers are ideal for applications requiring high integration, small size and low power.

Functional Block Diagram

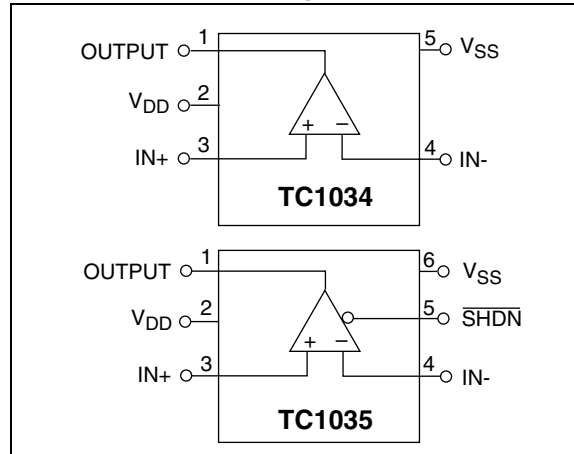

TC1034/TC1035

1.0 ELECTRICAL CHARACTERISTICS

ABSOLUTE MAXIMUM RATINGS*

Supply Voltage	6.0V
Voltage on Any Pin	($V_{SS} - 0.3V$) to ($V_{DD} + 0.3V$)
Junction Temperature.....	+150°C
Operating Temperature Range.....	-40°C to +85°C
Storage Temperature Range	-55°C to +150°C

*Stresses above those listed under "Absolute Maximum Ratings" may cause permanent damage to the device. These are stress ratings only and functional operation of the device at these or any other conditions above those indicated in the operation sections of the specifications is not implied. Exposure to Absolute Maximum Rating conditions for extended periods may affect device reliability.

TC1034/TC1035 ELECTRICAL SPECIFICATIONS

Electrical Characteristics: $T_A = -40^\circ\text{C}$ to $+85^\circ\text{C}$ and $V_{DD} = 1.8V$ to $5.5V$, unless otherwise specified. Typical values apply at 25°C . Minimum and maximum values apply for $V_{DD} = 3.0V$.

Symbol	Parameter	Min	Typ	Max	Units	Test Conditions
V_{DD}	Supply Voltage	1.8	—	5.5	V	
Shutdown Input (TC1035 Only)						
V_{IH}	Input High Threshold	80% V_{DD}	—	—	V	
V_{IL}	Input Low Threshold	—	—	20% V_{DD}	V	
I_{SI}	Shutdown Input Current (Note 1)	—	—	± 100	nA	
Op Amp						
I_Q	Supply Current, Operating (Note 1)	—	6	10	μA	Output Open, $\overline{\text{SHDN}} = V_{DD}$
I_{SHDN}	Supply Current, Shutdown Mode (Note 1)	—	0.05	0.1	μA	$\overline{\text{SHDN}} = V_{SS}$
$R_{OUT(SD)}$	Output Resistance in Shutdown (Note 1)	20	—	—	$\text{M}\Omega$	$\overline{\text{SHDN}} = V_{SS}$
$C_{OUT(SD)}$	Output Capacitance in Shutdown (Note 1)	—	—	5	pF	$\overline{\text{SHDN}} = V_{SS}$
T_{SEL}	Select Time (V_{OUT} from $\overline{\text{SHDN}} = V_{IH}$) (Note 1)	—	15	—	μsec	$R_L = 10\text{k}\Omega$ to V_{SS}
T_{DESEL}	Deselect Time (V_{OUT} from $\overline{\text{SHDN}} = V_{IL}$) (Note 1)	—	20	—	nsec	$R_L = 10\text{k}\Omega$ to V_{SS}
A_{VOL}	Large Signal Voltage Gain	—	100	—	V/mV	$R_O = 10\text{k}\Omega$, $V_{DD} = 5V$
V_{ICMR}	Common Mode Input Voltage Range	$V_{SS} - 0.2$	—	$V_{DD} + 0.2$	V	
V_{OS}	Input Offset Voltage (Note 1)		± 100 ± 0.3	± 500 ± 1.5	μV mV	$V_{DD} = 3V$, $V_{CM} = 1.5V$, $T_A = 25^\circ\text{C}$ $T_A = -40^\circ\text{C}$ to 85°C
I_B	Input Bias Current	-100	50	100	pA	$T_A = 25^\circ\text{C}$; $V_{CM} = V_{DD}$ to V_{SS}
$V_{OS(DRIFT)}$	Input Offset Voltage Drift	—	± 4	—	$\mu\text{V}/^\circ\text{C}$	$V_{DD} = 3V$; $V_{CM} = 1.5V$
GBWP	Gain Bandwidth Product	—	90	—	kHz	$V_{DD} = 1.8V$ to $5.5V$; $V_O = V_{DD}$ to V_{SS}
SR	Slew Rate	—	35	—	mV/ μsec	$C_L = 100\text{pF}$, $R_L = 1\text{M}\Omega$ to GND, Gain = 1, $V_{IN} = V_{SS}$ to V_{DD}
V_{OUT}	Output Signal Swing	$V_{SS} + 0.05$	—	$V_{DD} - 0.05$	V	$R_L = 10\text{k}\Omega$
CMRR	Common Mode Rejection Ratio	70	—	—	dB	$T_A = 25^\circ\text{C}$; $V_{DD} = 5V$ $V_{CM} = V_{DD}$ to V_{SS}
PSRR	Power Supply Rejection Ratio	80	—	—	dB	$T_A = 25^\circ\text{C}$, $V_{CM} = V_{SS}$ $V_{DD} = 1.8V$ to $5V$

Note 1: TC1035 only.

TC1034/TC1035 ELECTRICAL SPECIFICATIONS (CONTINUED)

Electrical Characteristics: $T_A = -40^\circ\text{ to }+85^\circ\text{C}$ and $V_{DD} = 1.8\text{V to }5.5\text{V}$, unless otherwise specified. Typical values apply at 25°C . Minimum and maximum values apply for $V_{DD} = 3.0\text{V}$.

Symbol	Parameter	Min	Typ	Max	Units	Test Conditions
I_{SRC}	Output Source Current	3	—	—	mA	$V_{IN+} = V_{DD}$, $V_{IN-} = V_{SS}$ Output Shorted to V_{SS} $V_{DD} = 1.8\text{V}$, Gain = 1
I_{SINK}	Output Sink Current	4	—	—	mA	$V_{IN+} = V_{SS}$, $V_{IN-} = V_{DD}$, Output Shorted to V_{DD} $V_{DD} = 1.8\text{V}$, Gain = 1
E_n	Input Noise Voltage	—	10	—	μV_{PP}	0.1Hz to 10Hz
e_n	Input Noise Voltage Density	—	125	—	$\text{nV}/\sqrt{\text{Hz}}$	1kHz

Note 1: TC1035 only.

TC1034/TC1035

2.0 PIN DESCRIPTIONS

The description of the pins are listed in Table 2-1.

TABLE 2-1: PIN FUNCTION TABLE

Pin No. TC1034 (5-Pin SOT-23A)	Symbol	Description
1	OUT	Operational amplifier output.
2	V_{DD}	Positive power supply.
3	IN+	Operational amplifier non-inverting input.
4	IN-	Operational amplifier inverting input.
5	V_{SS}	Negative power supply.

Pin No. TC1035 (6-Pin SOT-23A)	Symbol	Description
1	OUT	Operational amplifier output.
2	V_{DD}	Positive power supply.
3	IN+	Operational amplifier non-inverting input.
4	IN-	Operational amplifier inverting input.
5	$\overline{\text{SHDN}}$	Active Low Shutdown Input (TC1035 only). A low input on this pin disables the operational amplifier and places the output terminal in a high-impedance state.
6	V_{SS}	Negative power supply.

3.0 DETAILED DESCRIPTION

The TC1034/TC1035 is one of a series of very low power, linear building block products targeted at low voltage, single supply applications. The TC1034/TC1035 minimum operating voltage is 1.8V and maximum supply current is only 8 μ A. The TC1034 is a single op amp in a 5-Pin SOT-23A package, and the TC1035 is a single op amp with shutdown input in a 6-Pin SOT-23A package.

Microchip's op amps are internally compensated to be unity gain stable and have a typical gain bandwidth product of 90kHz with typical slew rates of 35V/msec.

The amplifier's input range extends beyond both supplies by 200mV and the outputs will swing to within several millivolts of the supplies depending on the load current being driven.

Input offset voltage is 500 μ V max at 25 $^{\circ}$ C with an input bias current of less than 100pA. This makes these devices extremely suitable for precision, low power applications.

4.0 TYPICAL APPLICATIONS

The TC1034/TC1035 lends itself to a wide variety of applications, particularly in battery powered systems. It typically finds applications in power management, processor supervisory and interface circuitry.

4.1 Voice Band Receive Filter

The majority of spectral energy for human voices is found to be in a 2.7kHz frequency band from 300Hz to 3kHz. To properly recover a voice signal in applications such as radios, cellular phones and voice pagers, a low power bandpass filter that is matched to the human voice spectrum can be implemented using Microchip's CMOS op amps. Figure 4-1 shows a unity gain multi-pole Butterworth filter with ripple less than 0.15dB in the human voice band. The lower 3dB cut-off frequency is 70Hz (single order response), while the upper cut-off frequency is 3.5kHz (fourth order response).

4.2 Supervisory Audio Tone (SAT) Filter for Cellular

Supervisory Audio Tones (SAT) provide a reliable transmission path between cellular subscriber units and base stations. The SAT tone functions much like the current/voltage used in land line telephone systems to indicate that a phone is off the hook. The SAT tone may be one of three frequencies: 5970, 6000 or 6030Hz. A loss of SAT implies that channel conditions are impaired and if SAT is interrupted for more than 5 seconds a cellular call is terminated.

Figure 4-2 shows a high Q (30) second order SAT detection bandpass filter using Microchip's CMOS op amp architecture. This circuit nulls all frequencies except the three SAT tones of interest.

TC1034/TC1035

FIGURE 4-1: MULTI-POLE BUTTERWORTH VOICE BAND RECEIVE FILTER

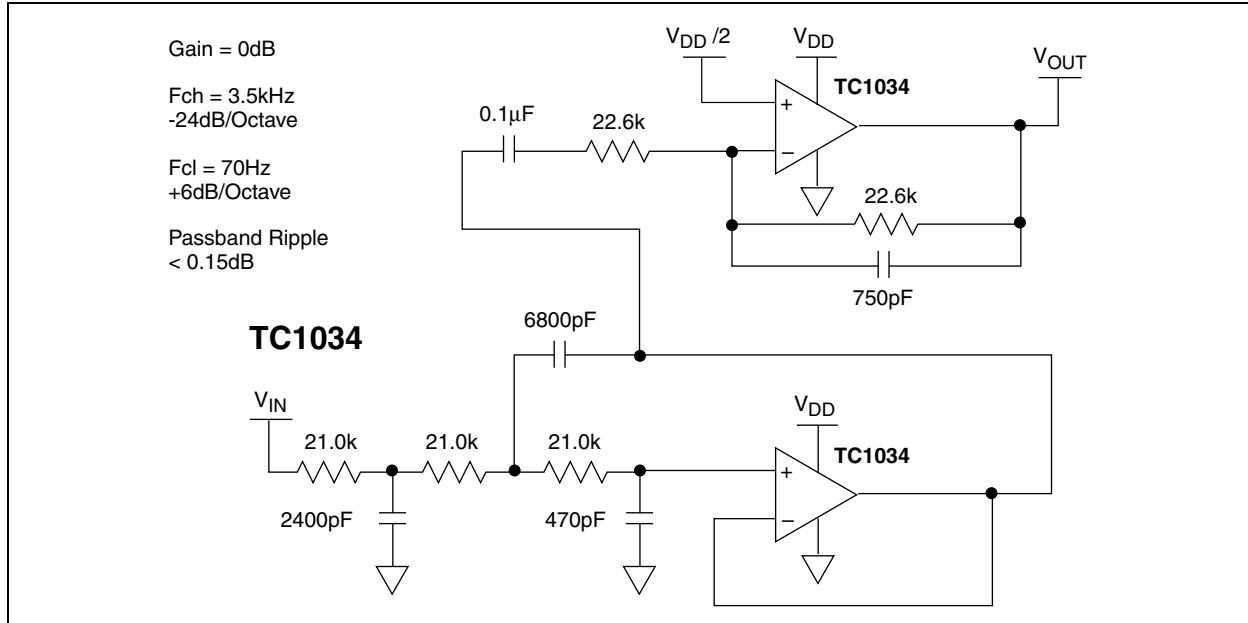
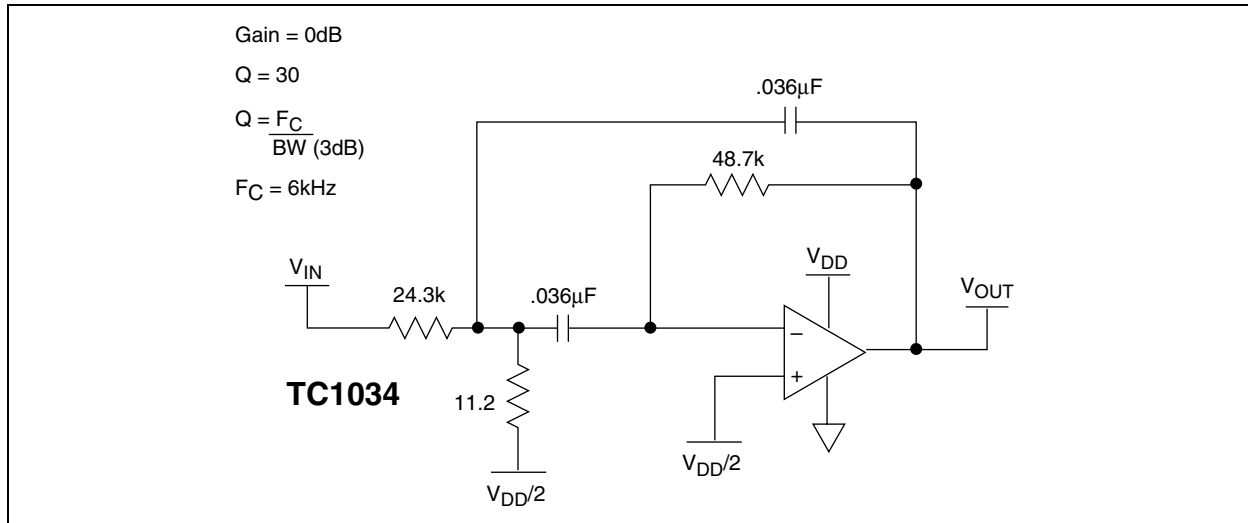
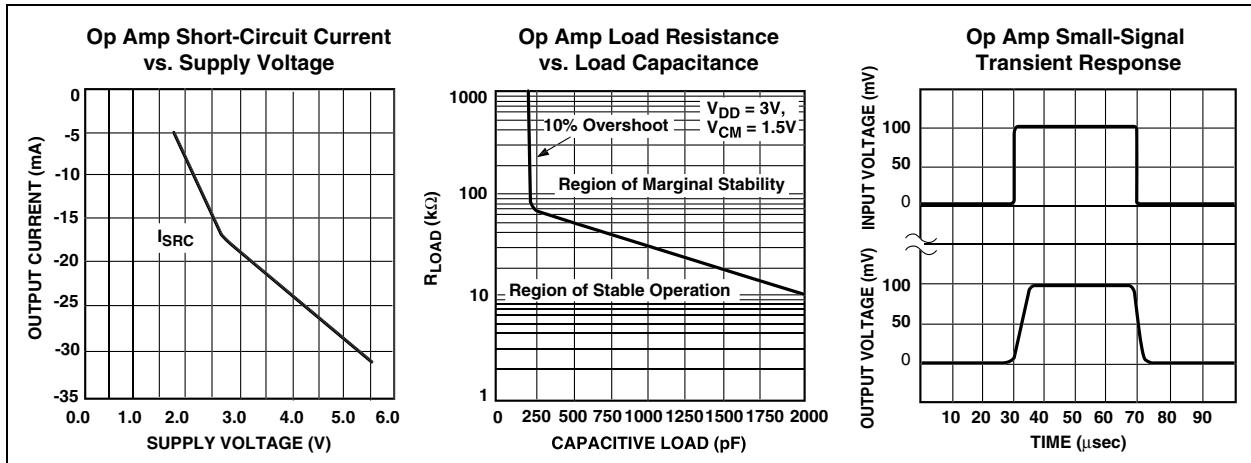
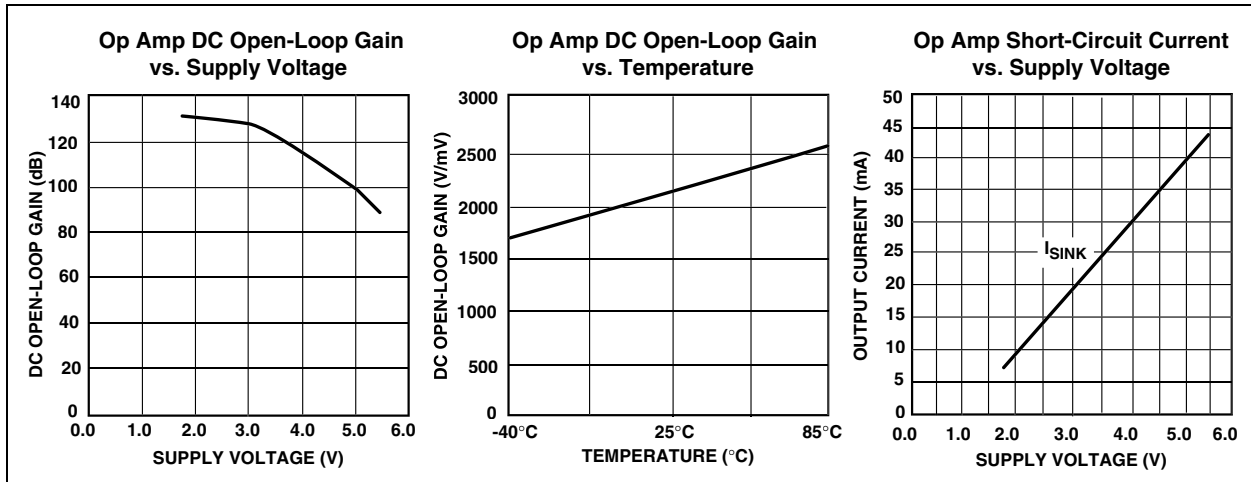
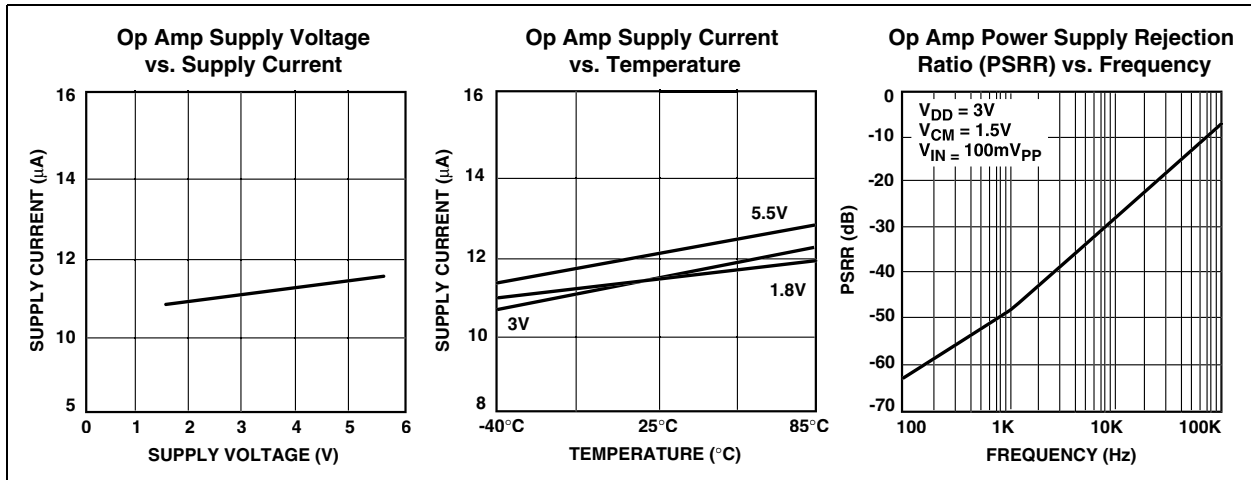

FIGURE 4-2: SECOND ORDER SAT BANDPASS FILTER



5.0 TYPICAL CHARACTERISTICS

Note: The graphs and tables provided following this note are a statistical summary based on a limited number of samples and are provided for informational purposes only. The performance characteristics listed herein are not tested or guaranteed. In some graphs or tables, the data presented may be outside the specified operating range (e.g., outside specified power supply range) and therefore outside the warranted range.



TC1034/TC1035

5.0 TYPICAL CHARACTERISTICS (CONTINUED)

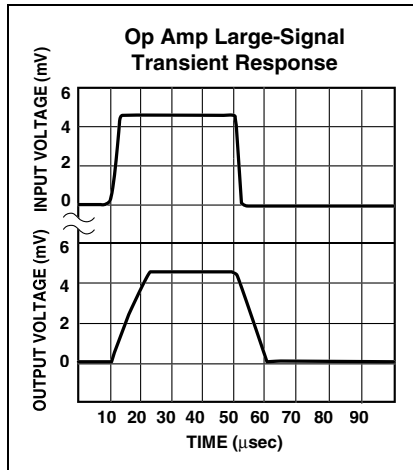

6.0 PACKAGING INFORMATION

6.1 Package Marking Information

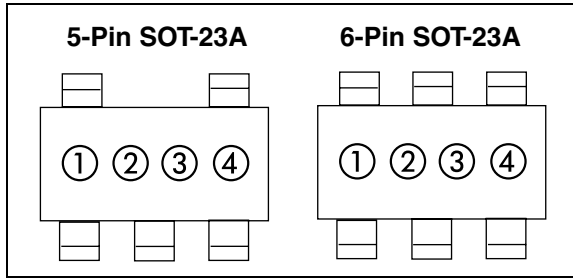

1 and 2 = part number code + temperature range and voltage

TC1034/TC1035 (V)	Code
TC1034ECT	AE
TC1035ECH	AF

3 = year and quarter code

4 = lot ID number

6.2 Taping Form

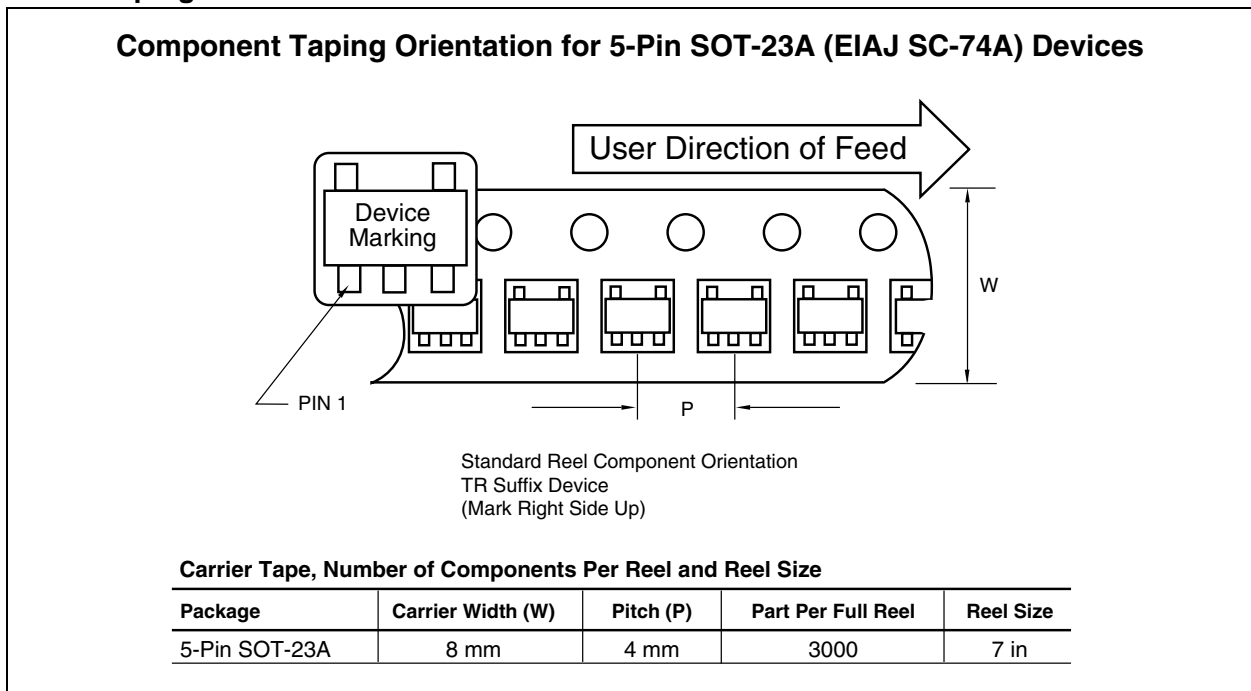

TC1034/TC1035

6.2 Taping Form (Continued)

Component Taping Orientation for 6-Pin SOT-23A (EIAJ SC-74) Devices

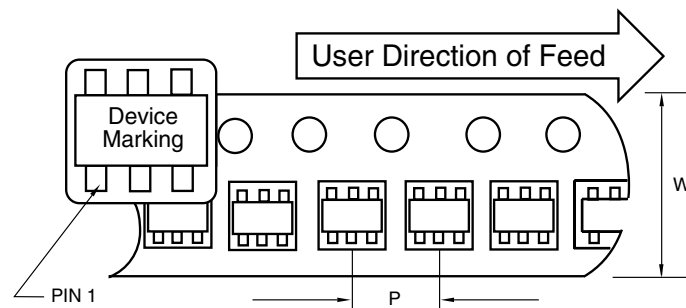

Standard Reel Component Orientation
For TR Suffix Device
(Mark Right Side Up)

Carrier Tape, Number of Components Per Reel and Reel Size

Package	Carrier Width (W)	Pitch (P)	Part Per Full Reel	Reel Size
6-Pin SOT-23A	8 mm	4 mm	3000	7 in

6.3 Package Dimensions

SOT-23A-5

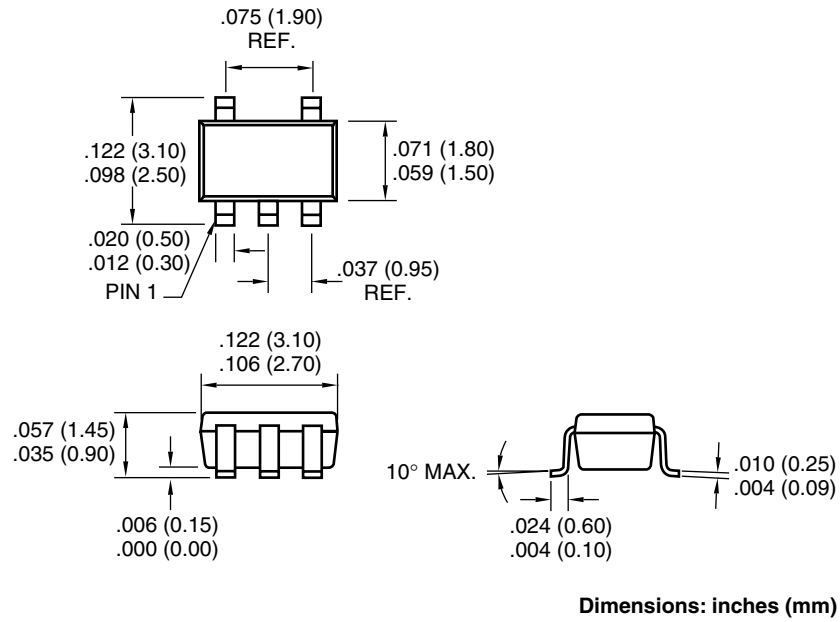

SOT-23A-6

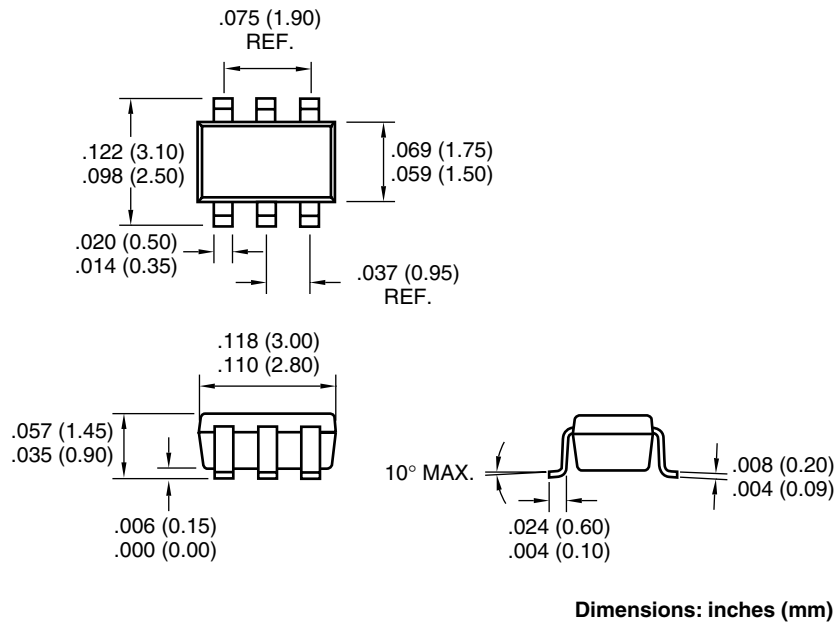

TC1034/TC1035

NOTES:

Sales and Support

Data Sheets

Products supported by a preliminary Data Sheet may have an errata sheet describing minor operational differences and recommended workarounds. To determine if an errata sheet exists for a particular device, please contact one of the following:

1. Your local Microchip sales office
2. The Microchip Corporate Literature Center U.S. FAX: (480) 792-7277
3. The Microchip Worldwide Site (www.microchip.com)

Please specify which device, revision of silicon and Data Sheet (include Literature #) you are using.

New Customer Notification System

Register on our web site (www.microchip.com/cn) to receive the most current information on our products.

TC1034/TC1035

NOTES:

Information contained in this publication regarding device applications and the like is intended through suggestion only and may be superseded by updates. It is your responsibility to ensure that your application meets with your specifications. No representation or warranty is given and no liability is assumed by Microchip Technology Incorporated with respect to the accuracy or use of such information, or infringement of patents or other intellectual property rights arising from such use or otherwise. Use of Microchip's products as critical components in life support systems is not authorized except with express written approval by Microchip. No licenses are conveyed, implicitly or otherwise, under any intellectual property rights.

Trademarks

The Microchip name and logo, the Microchip logo, FilterLab, KEELOQ, microID, MPLAB, PIC, PICmicro, PICMASTER, PICSTART, PRO MATE, SEEVAL and The Embedded Control Solutions Company are registered trademarks of Microchip Technology Incorporated in the U.S.A. and other countries.

dsPIC, ECONOMONITOR, FanSense, FlexROM, fuzzyLAB, In-Circuit Serial Programming, ICSP, ICEPIC, microPort, Migratable Memory, MPASM, MPLIB, MPLINK, MPSIM, MXDEV, PICC, PICDEM, PICDEM.net, rfPIC, Select Mode and Total Endurance are trademarks of Microchip Technology Incorporated in the U.S.A.

Serialized Quick Turn Programming (SQTP) is a service mark of Microchip Technology Incorporated in the U.S.A.

All other trademarks mentioned herein are property of their respective companies.

© 2002, Microchip Technology Incorporated, Printed in the U.S.A., All Rights Reserved.

 Printed on recycled paper.

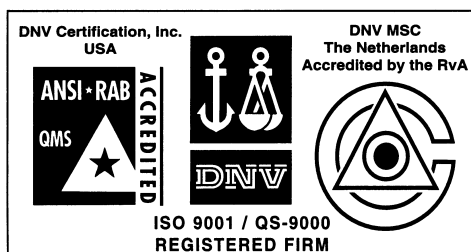

Microchip received QS-9000 quality system certification for its worldwide headquarters, design and wafer fabrication facilities in Chandler and Tempe, Arizona in July 1999 and Mountain View, California in March 2002. The Company's quality system processes and procedures are QS-9000 compliant for its PICmicro® 8-bit MCUs, KEELOQ® code hopping devices, Serial EEPROMs, microperipherals, non-volatile memory and analog products. In addition, Microchip's quality system for the design and manufacture of development systems is ISO 9001 certified.



MICROCHIP

WORLDWIDE SALES AND SERVICE

AMERICAS

Corporate Office

2355 West Chandler Blvd.
Chandler, AZ 85224-6199
Tel: 480-792-7200 Fax: 480-792-7277
Technical Support: 480-792-7627
Web Address: <http://www.microchip.com>

Rocky Mountain

2355 West Chandler Blvd.
Chandler, AZ 85224-6199
Tel: 480-792-7966 Fax: 480-792-7456

Atlanta

500 Sugar Mill Road, Suite 200B
Atlanta, GA 30350
Tel: 770-640-0034 Fax: 770-640-0307

Boston

2 Lan Drive, Suite 120
Westford, MA 01886
Tel: 978-692-3848 Fax: 978-692-3821

Chicago

333 Pierce Road, Suite 180
Itasca, IL 60143
Tel: 630-285-0071 Fax: 630-285-0075

Dallas

4570 Westgrove Drive, Suite 160
Addison, TX 75001
Tel: 972-818-7423 Fax: 972-818-2924

Detroit

Tri-Atria Office Building
32255 Northwestern Highway, Suite 190
Farmington Hills, MI 48334
Tel: 248-538-2250 Fax: 248-538-2260

Kokomo

2767 S. Albright Road
Kokomo, Indiana 46902
Tel: 765-864-8360 Fax: 765-864-8387

Los Angeles

18201 Von Karman, Suite 1090
Irvine, CA 92612
Tel: 949-263-1888 Fax: 949-263-1338

New York

150 Motor Parkway, Suite 202
Hauppauge, NY 11788
Tel: 631-273-5305 Fax: 631-273-5335

San Jose

Microchip Technology Inc.
2107 North First Street, Suite 590
San Jose, CA 95131
Tel: 408-436-7950 Fax: 408-436-7955

Toronto

6285 Northam Drive, Suite 108
Mississauga, Ontario L4V 1X5, Canada
Tel: 905-673-0699 Fax: 905-673-6509

ASIA/PACIFIC

Australia

Microchip Technology Australia Pty Ltd
Suite 22, 41 Rawson Street
Epping 2121, NSW
Australia
Tel: 61-2-9868-6733 Fax: 61-2-9868-6755

China - Beijing

Microchip Technology Consulting (Shanghai)
Co., Ltd., Beijing Liaison Office
Unit 915
Bei Hai Wan Tai Bldg.
No. 6 Chaoyangmen Beidajie
Beijing, 100027, No. China
Tel: 86-10-85282100 Fax: 86-10-85282104

China - Chengdu

Microchip Technology Consulting (Shanghai)
Co., Ltd., Chengdu Liaison Office
Rm. 2401, 24th Floor,
Ming Xing Financial Tower
No. 88 TIDU Street
Chengdu 610016, China
Tel: 86-28-6766200 Fax: 86-28-6766599

China - Fuzhou

Microchip Technology Consulting (Shanghai)
Co., Ltd., Fuzhou Liaison Office
Unit 28F, World Trade Plaza
No. 71 Wusi Road
Fuzhou 350001, China
Tel: 86-591-7503506 Fax: 86-591-7503521

China - Shanghai

Microchip Technology Consulting (Shanghai)
Co., Ltd.
Room 701, Bldg. B
Far East International Plaza
No. 317 Xian Xia Road
Shanghai, 200051
Tel: 86-21-6275-5700 Fax: 86-21-6275-5060

China - Shenzhen

Microchip Technology Consulting (Shanghai)
Co., Ltd., Shenzhen Liaison Office
Rm. 1315, 13/F, Shenzhen Kerry Centre,
Renminnan Lu
Shenzhen 518001, China
Tel: 86-755-2350361 Fax: 86-755-2366086

Hong Kong

Microchip Technology Hongkong Ltd.
Unit 901-6, Tower 2, Metroplaza
223 Hing Fong Road
Kwai Fong, N.T., Hong Kong
Tel: 852-2401-1200 Fax: 852-2401-3431

India

Microchip Technology Inc.
India Liaison Office
Divyasree Chambers
1 Floor, Wing A (A3/A4)
No. 11, O'Shaugnessey Road
Bangalore, 560 025, India
Tel: 91-80-2290061 Fax: 91-80-2290062

Japan

Microchip Technology Japan K.K.
Benex S-1 6F
3-18-20, Shinyokohama
Kohoku-Ku, Yokohama-shi
Kanagawa, 222-0033, Japan
Tel: 81-45-471-6166 Fax: 81-45-471-6122

Korea

Microchip Technology Korea
168-1, Youngbo Bldg. 3 Floor
Samsung-Dong, Kangnam-Ku
Seoul, Korea 135-882
Tel: 82-2-554-7200 Fax: 82-2-558-5934

Singapore

Microchip Technology Singapore Pte Ltd.
200 Middle Road
#07-02 Prime Centre
Singapore, 188980
Tel: 65-6334-8870 Fax: 65-6334-8850

Taiwan

Microchip Technology Taiwan
11F-3, No. 207
Tung Hua North Road
Taipei, 105, Taiwan
Tel: 886-2-2717-7175 Fax: 886-2-2545-0139

EUROPE

Denmark

Microchip Technology Nordic ApS
Regus Business Centre
Lautrup høj 1-3
Ballerup DK-2750 Denmark
Tel: 45 4420 9895 Fax: 45 4420 9910

France

Microchip Technology SARL
Parc d'Activite du Moulin de Massy
43 Rue du Saule Trapu
Batiment A - 1er Etage
91300 Massy, France
Tel: 33-1-69-53-63-20 Fax: 33-1-69-30-90-79

Germany

Microchip Technology GmbH
Gustav-Heinemann Ring 125
D-81739 Munich, Germany
Tel: 49-89-627-144 0 Fax: 49-89-627-144-44

Italy

Microchip Technology SRL
Centro Direzionale Colleoni
Palazzo Taurus 1 V. Le Colleoni 1
20041 Agrate Brianza
Milan, Italy
Tel: 39-039-65791-1 Fax: 39-039-6899883

United Kingdom

Arizona Microchip Technology Ltd.
505 Eskdale Road
Winnersh Triangle
Wokingham
Berkshire, England RG41 5TU
Tel: 44 118 921 5869 Fax: 44-118 921-5820

03/01/02

