

## Linear Building Block – Low Power Comparator with Op Amp and Voltage Reference

### Features

- Combines Low-Power Op Amp, Comparator and Voltage Reference in a Single Package
- Optimized for Single Supply Operation
- Small Packages: 8-Pin MSOP, 8-Pin SOIC, 8-Pin PDIP
- Ultra Low Input Bias Current: Less than 100pA
- Low Quiescent Current: 12 $\mu$ A (Typ.)
- Rail-to-Rail Inputs and Outputs
- Operates Down to  $V_{DD} = 1.8V$ , Min

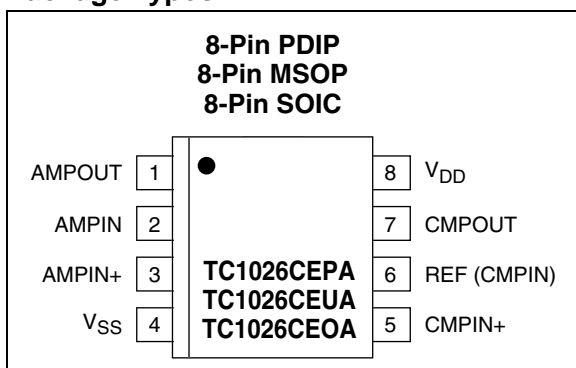
### Applications

- Power Management Circuits
- Battery Operated Equipment
- Consumer Products

### Device Selection Table

Part Number	Package	Temperature Range
TC1026CEPA	8-Pin PDIP	-40°C to +85°C
TC1026CEUA	8-Pin MSOP	-40°C to +85°C
TC1026CEOA	8-Pin SOIC	-40°C to +85°C

### Package Types



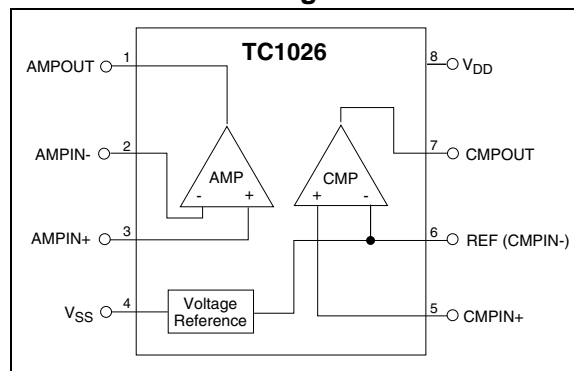
### General Description

The TC1026 is a mixed-function device combining a general-purpose op amp, comparator and voltage reference in a single 8-pin package. This increased integration allows the user to replace two or three packages, which saves space, lowers supply current and increases system performance.

Both the op amp and comparator have rail-to-rail inputs and outputs which allows operation from low supply voltages with large input and output swings. The TC1026 is optimized for low voltage ( $V_{DD} = 1.8V$ ), low supply current (12 $\mu$ A typ) operation.

Packaged in a space-saving 8-Pin MSOP, the TC1026 consumes half the board area of an 8-Pin SOIC and is ideal for applications requiring high integration, small size and low power. It is also available in 8-Pin SOIC and 8-Pin PDIP packages.

### Functional Block Diagram



# TC1026

## 1.0 ELECTRICAL CHARACTERISTICS

### ABSOLUTE MAXIMUM RATINGS\*

Supply Voltage .....	6.0V
Package Power Dissipation:	
8-Pin PDIP .....	730 mW
8-Pin SOIC .....	470 mW
8-Pin MSOP .....	320 mW
Voltage on Any Pin .....	( $V_{SS} - 0.3V$ ) to ( $V_{DD} + 0.3V$ )
Junction Temperature .....	+150°C
Operating Temperature Range .....	-40°C to +85°C
Storage Temperature Range .....	-55°C to +150°C

\*Stresses above those listed under "Absolute Maximum Ratings" may cause permanent damage to the device. These are stress ratings only and functional operation of the device at these or any other conditions above those indicated in the operation sections of the specifications is not implied. Exposure to Absolute Maximum Rating conditions for extended periods may affect device reliability.

### TC1026 ELECTRICAL SPECIFICATIONS

Electrical Characteristics: Typical values apply at 25°C and $V_{DD} = 3.0V$ ; $T_A = -40^\circ$ to $+85^\circ C$ , and $V_{DD} = 1.8V$ to $5.5V$ , unless otherwise specified.						
Symbol	Parameter	Min	Typ	Max	Units	Test Conditions
$V_{DD}$	Supply Voltage	1.8	—	5.5	V	
$I_Q$	Supply Current	—	12	18	$\mu A$	All outputs unloaded
<b>Op Amp</b>						
$A_{VOL}$	Large Signal Voltage Gain	—	100	—	V/mV	$R_L = 10k\Omega$ , $V_{DD} = 5V$
$V_{ICMR}$	Common Mode Input Range	$V_{SS} - 0.2$	—	$V_{DD} + 0.2$	V	
$V_{OS}$	Input Offset Voltage		$\pm 100$ $\pm 0.3$	$\pm 500$ $\pm 1.5$	$\mu V$ mV	$V_{DD} = 3V$ , $V_{CM} = 1.5V$ , $T_A = 25^\circ C$ $T_A = -40^\circ C$ to $85^\circ C$
$I_B$	Input Bias Current	-100	50	100	pA	$T_A = 25^\circ C$ , $V_{CM} = V_{DD}$ to $V_{SS}$
$V_{OS (DRIFT)}$	Input Offset Voltage Drift	—	$\pm 4$	—	$\mu V/^\circ C$	$V_{DD} = 3V$ , $V_{CM} = 1.5V$
GBWP	Gain-Bandwidth Product	—	90	—	kHz	$V_{DD} = 1.8V$ to $5.5V$ ; $V_O = V_{DD}$ to $V_{SS}$
SR	Slew Rate	—	35	—	mV/ $\mu sec$	$C_L = 100pF$ $R_L = 1M\Omega$ to GND Gain = 1 $V_{IN} = V_{SS}$ to $V_{DD}$
$V_{OUT}$	Output Signal Swing	$V_{SS} + 0.05$	—	$V_{DD} - 0.05$	V	$R_L = 10k\Omega$
CMRR	Common Mode Rejection Ratio	66	—	—	dB	$T_A = 25^\circ C$ , $V_{DD} = 5V$ $V_{CM} = V_{DD}$ to $V_{SS}$
PSRR	Power Supply Rejection Ratio	80	—	—	dB	$T_A = 25^\circ C$ , $V_{CM} = V_{SS}$ $V_{DD} = 1.8V$ to $5V$
$I_{SRC}$	Output Source Current	3	—	—	mA	$V_{IN+} = V_{DD}$ , $V_{IN-} = V_{SS}$ Output Shorted to $V_{SS}$ $V_{DD} = 1.8V$ , Gain = 1
$I_{SINK}$	Output Slnk Current	—	125	—	nV/Hz	$IN+ = V_{SS}$ , $IN- = V_{DD}$ Output Shorted to $V_{DD}$ $V_{DD} = 1.8V$ , Gain = 1
$E_n$	Input Noise Voltage	—	10	—	$\mu V_{pp}$	0.1Hz to 10Hz
$e_n$	Input Noise Voltage Density	—	125	—	nV/ $\sqrt{Hz}$	1kHz
<b>Comparator</b>						
$V_{IR}$	Input Voltage Range	$V_{SS} - 0.2$	—	$V_{DD} + 0.2$	V	
$V_{OS}$	Input Offset Voltage	-5 -5	—	+5 +5	mV	$V_{DD} = 3V$ , $T_A = 25^\circ C$ $T_A = -40^\circ C$ to $85^\circ C$
$I_B$	Input Bias Current	—	—	$\pm 100$	pA	$T_A = 25^\circ C$ , $IN+ = V_{DD}$ to $V_{SS}$
$V_{OH}$	Output High Voltage	$V_{DD} - 0.3$	—	—	V	$R_L = 10k\Omega$ to $V_{SS}$
$V_{OL}$	Output Low Voltage	—	—	0.3	V	$R_L = 10k\Omega$ to $V_{DD}$

## TC1026 ELECTRICAL SPECIFICATIONS (CONTINUED)

<b>Electrical Characteristics:</b> Typical values apply at 25°C and $V_{DD} = 3.0V$ ; $T_A = -40^\circ$ to $+85^\circ C$ , and $V_{DD} = 1.8V$ to $5.5V$ , unless otherwise specified.						
Symbol	Parameter	Min	Typ	Max	Units	Test Conditions
PSRR	Power Supply Rejection Ratio	60	—	—	dB	$T_A = 25^\circ C$ $V_{DD} = 1.8V$ to $5V$
$I_{SRC}$	Output Source Current	1	—	—	mA	$IN+ = V_{DD}$ Output Shorted to $V_{SS}$ $V_{DD} = 1.8V$
$I_{SINK}$	Output Sink Current	2	—	—	mA	$IN+ = V_{SS}$ Output Shorted to $V_{DD}$ $V_{DD} = 1.8V$
$t_{PD1}$	Response Time	—	4	—	$\mu sec$	100mV Overdrive, $C_L = 100pF$
$t_{PD2}$	Response Time	—	6	—	$\mu sec$	10mV Overdrive, $C_L = 100pF$
<b>Voltage Reference</b>						
$V_{REF}$	Reference Voltage	1.176	1.200	1.221	V	
$I_{REF(SOURCE)}$	Source Current	50	—	—	$\mu A$	
$I_{REF(SINK)}$	Sink Current	50	—	—	$\mu A$	
$C_{L(REF)}$	Load Capacitance	—	—	100	pF	

# TC1026

---

---

## 2.0 PIN DESCRIPTION

The description of the pins are listed in Table 2-1.

**TABLE 2-1: PIN FUNCTION TABLE**

Pin No. (8-Pin PDIP) (8-Pin MSOP) (8-Pin SOIC)	Symbol	Description
1	AMPOUT	Op amp output.
2	AMPIN-	Inverting op amp input.
3	AMPIN+	Non-inverting op amp input.
4	V <sub>SS</sub>	Negative power supply.
5	CMPIN+	Non-inverting comparator input.
6	REF(CMPIN)	Inverting comparator input and voltage reference output voltage.
7	CMPOUT	Comparator output.
8	V <sub>DD</sub>	Positive power supply.

## 3.0 DETAILED DESCRIPTION

The TC1026 is one of a series of very low power, linear building block products targeted at low voltage, single supply applications. The TC1026 minimum operating voltage is 1.8V, and typical supply current is only 12μA. It combines a comparator, an op amp and a voltage reference in a single package.

### 3.1 Comparator

The TC1026 contains one comparator. The comparator's input range extends beyond both supply voltages by 200mV and the outputs will swing to within several millivolts of the supplies depending on the load current being driven. The inverting input is internally connected to the output of the reference.

The comparator exhibits propagation delay and supply current which are largely independent of supply voltage. The low input bias current and offset voltage make it suitable for high impedance precision applications.

### 3.2 Operational Amplifier

The TC1026 contains one rail-to-rail op amp. The amplifier's input range extends beyond both supplies by 200mV and the outputs will swing to within several millivolts of the supplies depending on the load current being driven.

The amplifier design is such that large signal gain, slew rate and bandwidth are largely independent of supply voltage. The low input bias current and offset voltage of the TC1026 make it suitable for precision applications.

### 3.3 Voltage Reference

A 2.0% tolerance, internally biased, 1.20V bandgap voltage reference is included in the TC1026. It has a push-pull output capable of sourcing and sinking at least 50μA.

## 4.0 TYPICAL APPLICATIONS

The TC1026 lends itself to a wide variety of applications, particularly in battery powered systems. It typically finds application in power management, processor supervisory and interface circuitry.

### 4.1 External Hysteresis (Comparator)

Hysteresis can be set externally with three resistors using positive feedback techniques (see Figure 4-1). The design procedure for setting external comparator hysteresis is as follows:

1. Choose the feedback resistor  $R_C$ . Since the input bias current of the comparator is at most 100pA, the current through  $R_C$  can be set to 100nA (i.e., 1000 times the input bias current) and retain excellent accuracy. The current through  $R_C$  at the comparator's trip point is  $V_R / R_C$  where  $V_R$  is a stable reference voltage.
2. Determine the hysteresis voltage ( $V_{HY}$ ) between the upper and lower thresholds.
3. Calculate  $R_A$  as follows:

#### EQUATION 4-1:

$$R_A = R_C \left( \frac{V_{HY}}{V_{DD}} \right)$$

4. Choose the rising threshold voltage for  $V_{SRC}$  ( $V_{THR}$ ).
5. Calculate  $R_B$  as follows:

#### EQUATION 4-2:

$$R_B = \frac{1}{\left[ \left( \frac{V_{THR}}{V_R \times R_A} \right) - \frac{1}{R_A} - \frac{1}{R_C} \right]}$$

6. Verify the threshold voltages with these formulas:

$V_{SRC}$  rising:

#### EQUATION 4-3:

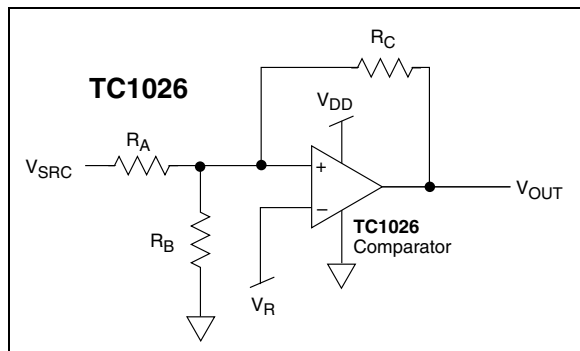
$$V_{THR} = (V_R)(R_A) \left[ \left( \frac{1}{R_A} \right) + \left( \frac{1}{R_B} \right) + \left( \frac{1}{R_C} \right) \right]$$

$V_{SRC}$  falling:

#### EQUATION 4-4:

$$V_{THF} = V_{THR} - \left[ \left( \frac{R_A \times V_{DD}}{R_C} \right) \right]$$

**FIGURE 4-1: COMPARATOR EXTERNAL HYSTERESIS CONFIGURATION**



## 4.2 Precision Battery Monitor

Figure 4-2 is a precision battery low/battery dead monitoring circuit. Typically, the battery low output warns the user that a battery dead condition is imminent. Battery dead typically initiates a forced shutdown to prevent operation at low internal supply voltages (which can cause unstable system operation).

The circuit of Figure 4-2 uses two TC1026 devices and only six external resistors. AMP 1 is a simple buffer while CMPTR1 and CMPTR2 provide precision voltage detection using  $V_R$  as a reference. Resistors R2 and R4 set the detection threshold for BATT LOW while resistors R1 and R3 set the detection threshold for BATT FAIL. The component values shown assert BATT LOW at 2.2V (typical) and BATT FAIL at 2.0V (typical). Total current consumed by this circuit is typically 28 $\mu$ A at 3V. Resistors R5 and R6 provide hysteresis for comparators CMPTR1 and CMPTR2, respectively.

## 4.3 Voice Band Receive Filter

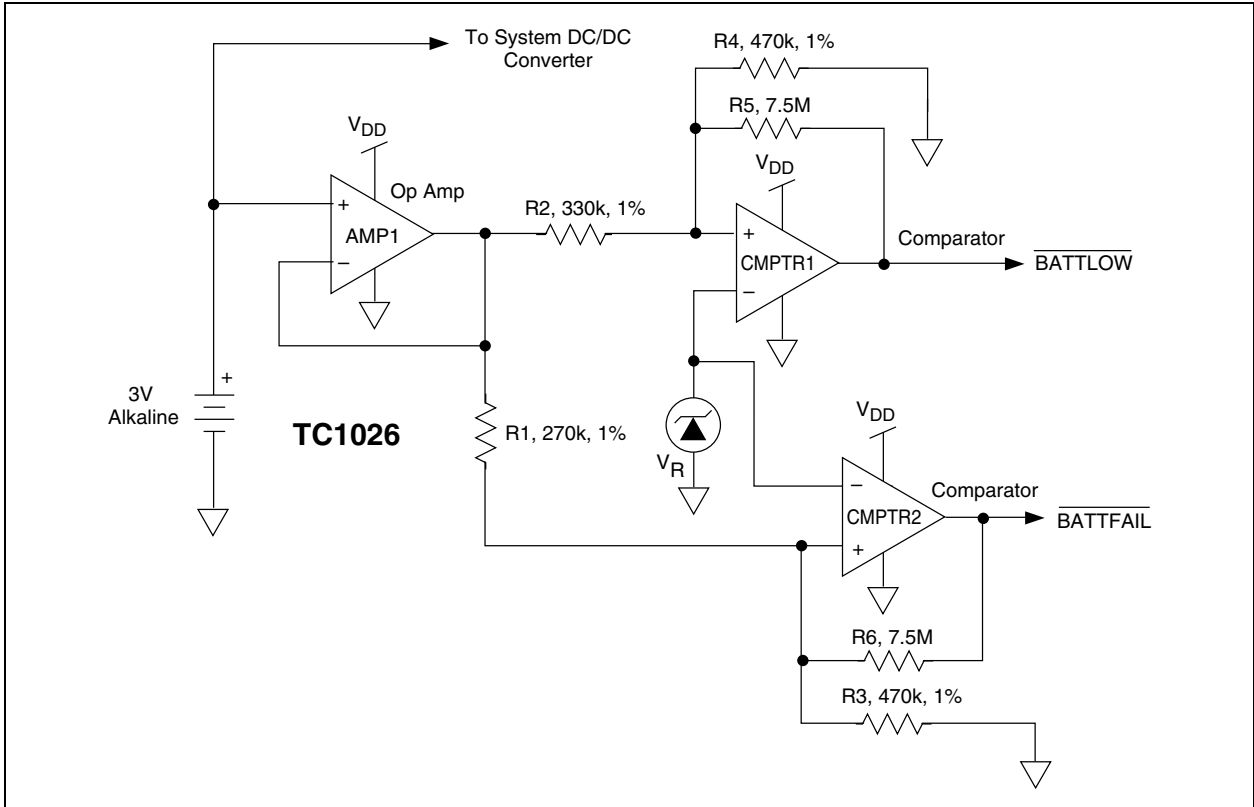
The majority of spectral energy for human voices is in a 2.7kHz frequency band from 300Hz to 3kHz. To properly recover a voice signal in applications such as radios, cellular phones and voice pagers, a low-power bandpass filter that is matched to the human voice spectrum can be implemented using Microchip's CMOS op amps. Figure 4-3 shows a unity-gain multipole Butterworth filter with ripple less than 0.15dB in the human voice band. The lower 3dB cut-off frequency is 70Hz (single-order response), while the upper cut-off frequency is 3.5kHz (fourth-order response).

## 4.4 Supervisory Audio Tone (SAT) Filter for Cellular

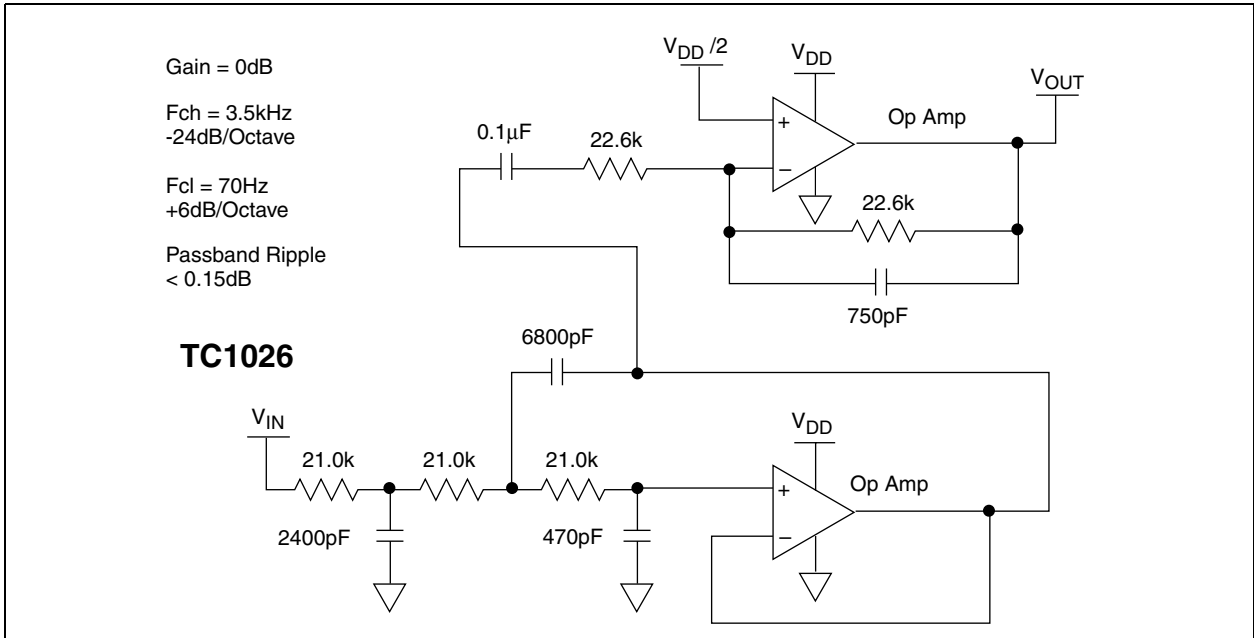
Supervisory Audio Tones (SAT) provide a reliable transmission path between cellular subscriber units and base stations. The SAT tone functions much like the current/voltage used in land line telephone systems to indicate that a phone is off the hook. The SAT tone may be one of three frequencies: 5970, 6000 or 6030Hz. A loss of SAT implies that channel conditions are impaired, and if SAT is interrupted for more than 5 seconds, a cellular call is terminated.

Figure 4-4 shows a high Q (30) first order SAT detection bandpass filter using Microchip's CMOS op amp architecture. This circuit nulls all frequencies except the three SAT tones of interest.

**FIGURE 4-2: PRECISION BATTERY MONITOR**

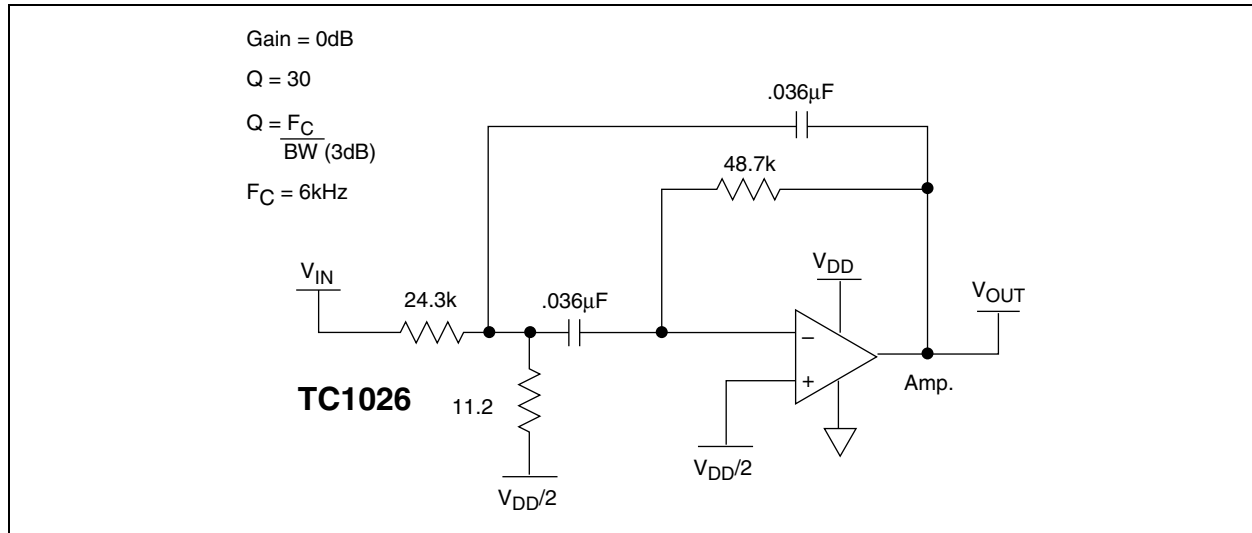


**FIGURE 4-3: MULTI-POLE BUTTERWORTH VOICE BAND RECEIVE FILTER**



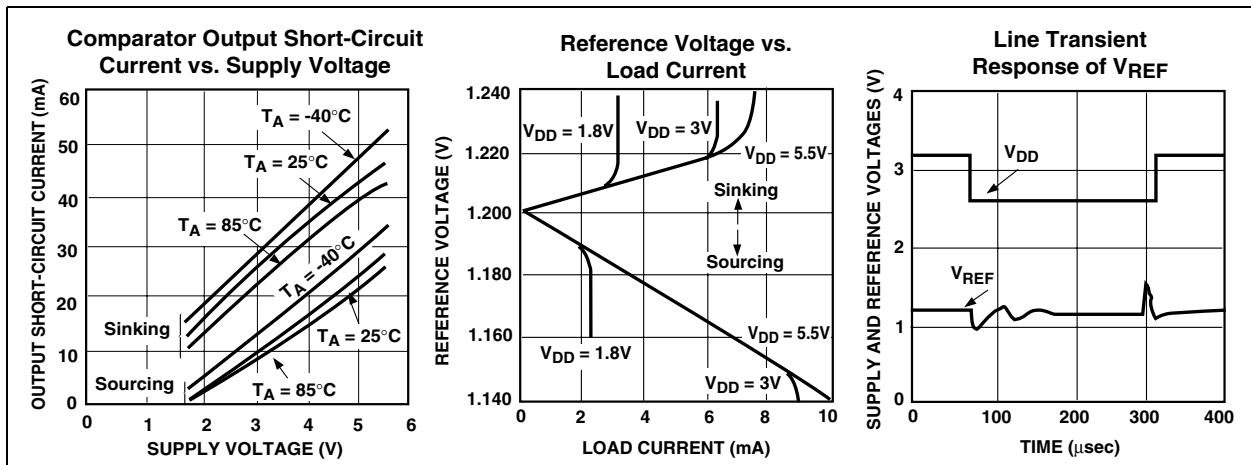
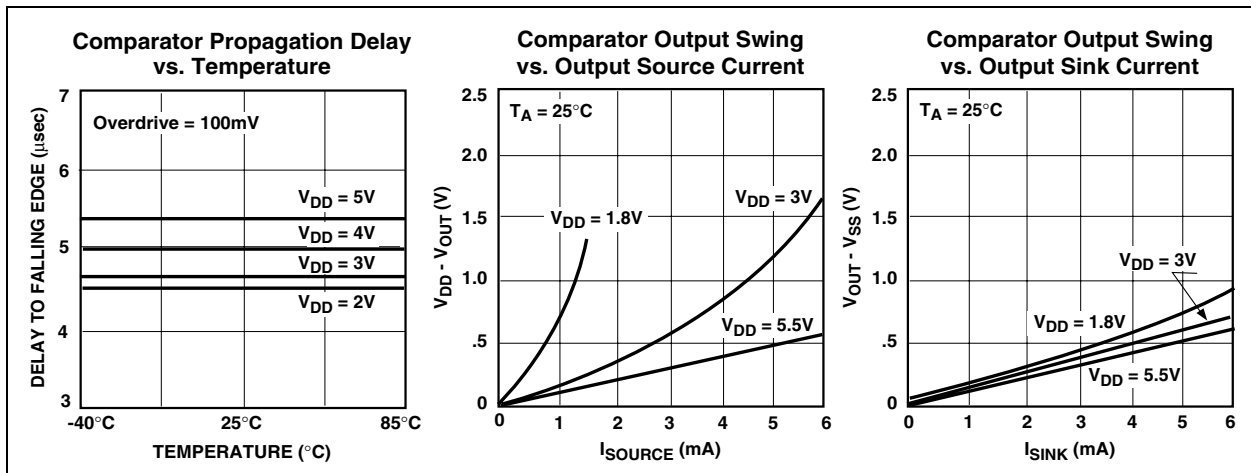
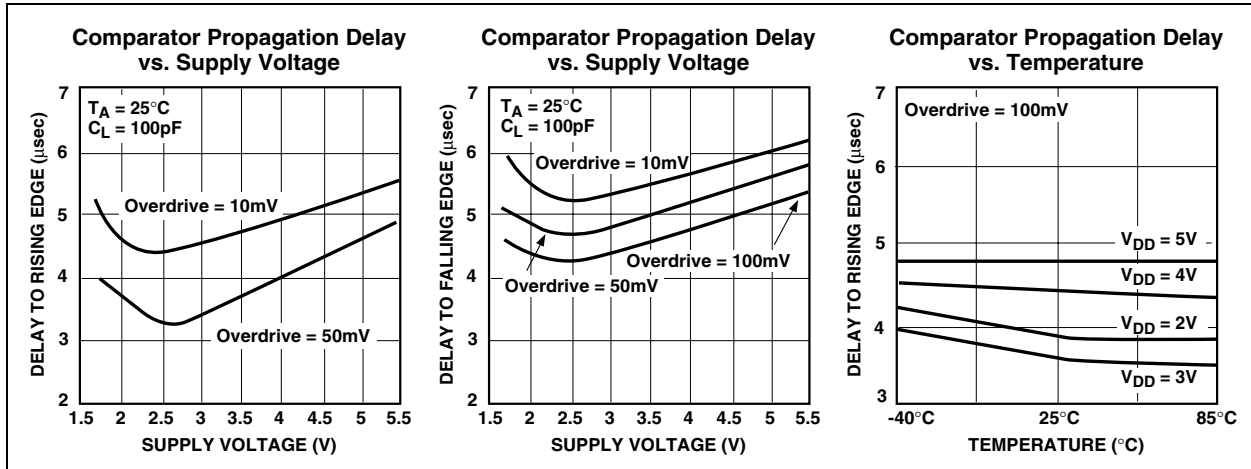
# TC1026

FIGURE 4-4: SECOND ORDER SAT BANDPASS FILTER

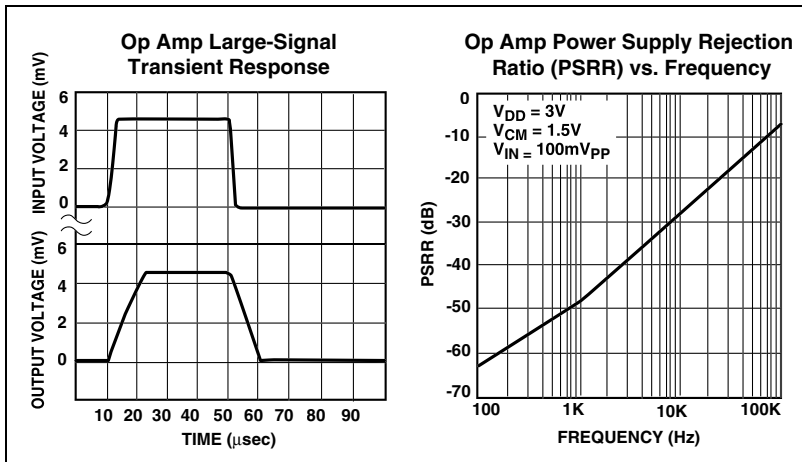
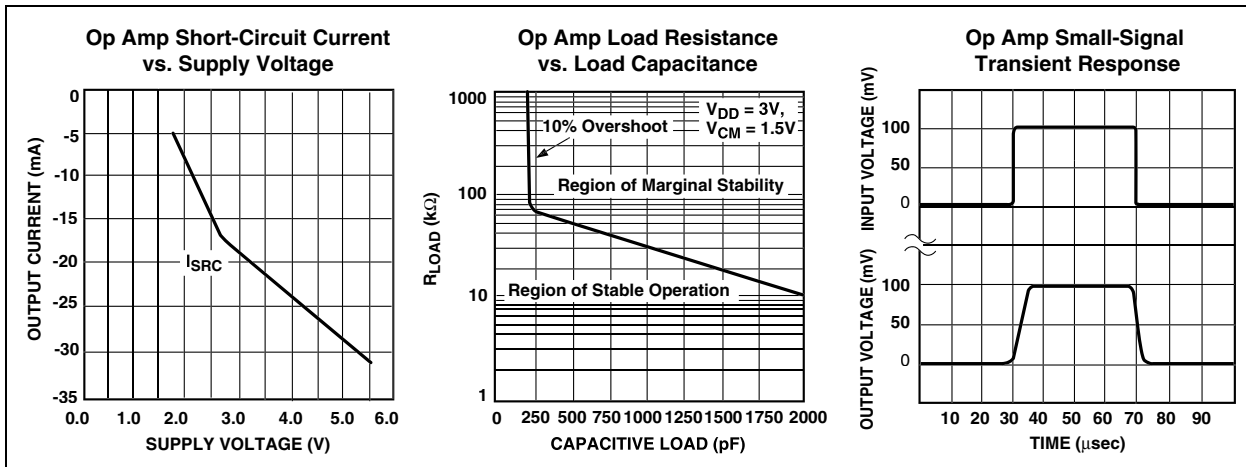
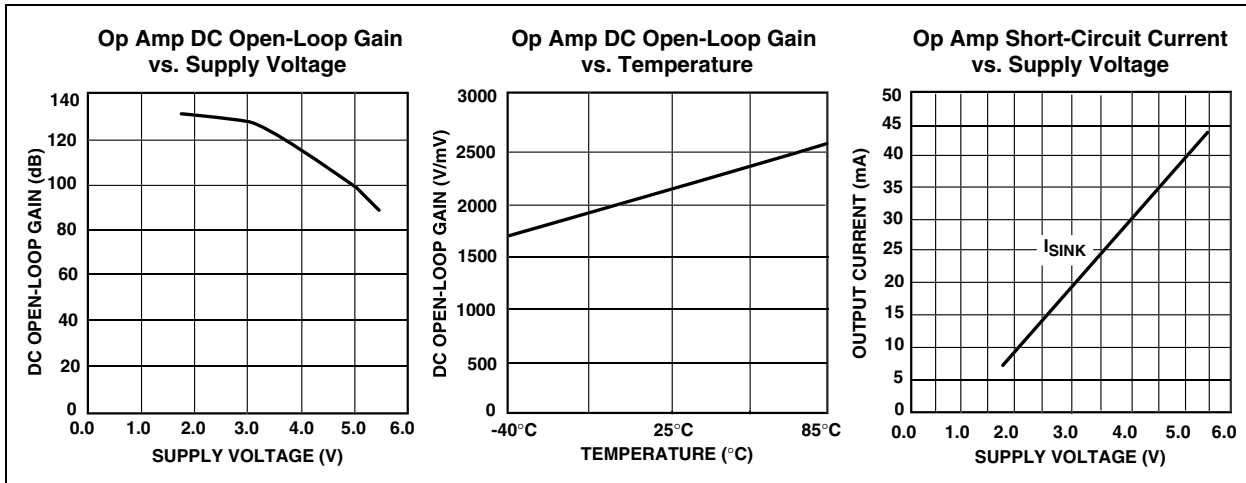


## 5.0 TYPICAL CHARACTERISTICS

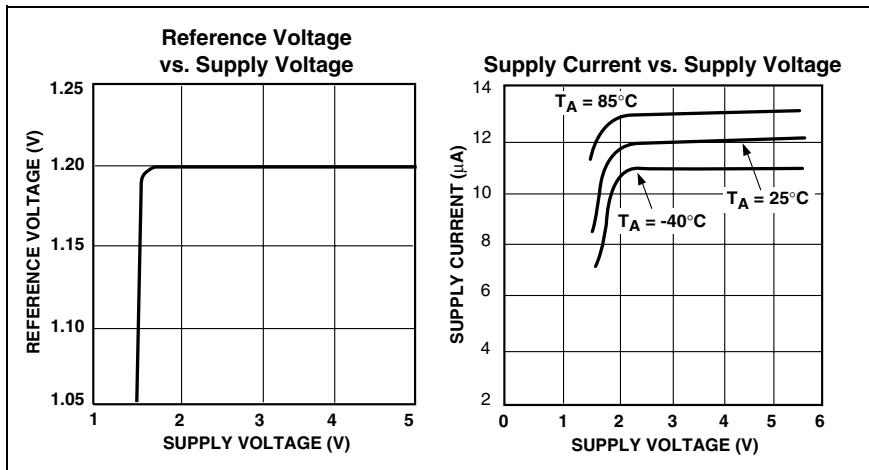
**Note:** The graphs and tables provided following this note are a statistical summary based on a limited number of samples and are provided for informational purposes only. The performance characteristics listed herein are not tested or guaranteed. In some graphs or tables, the data presented may be outside the specified operating range (e.g., outside specified power supply range) and therefore outside the warranted range.



## 5.0 TYPICAL CHARACTERISTICS (CONTINUED)



## 5.0 TYPICAL CHARACTERISTICS (CONTINUED)



# TC1026

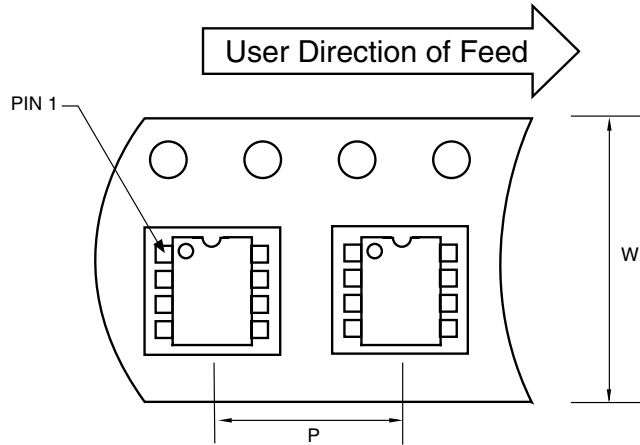
## 6.0 PACKAGING INFORMATION

### 6.1 Package Marking Information

Package marking data not available at this time.

### 6.2 Taping Form

#### Component Taping Orientation for 8-Pin MSOP Devices

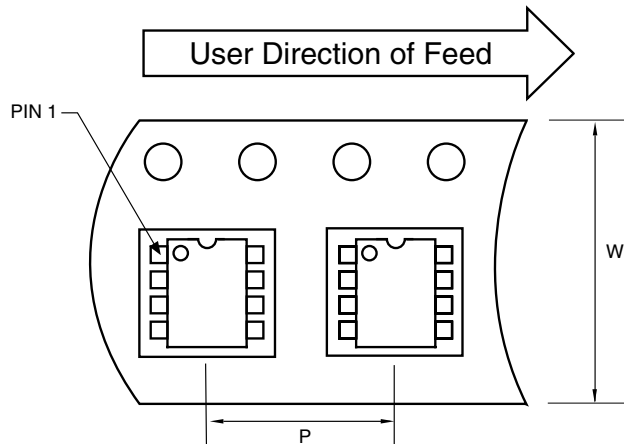


Standard Reel Component Orientation  
for TR Suffix Device

**Carrier Tape, Number of Components Per Reel and Reel Size**

Package	Carrier Width (W)	Pitch (P)	Part Per Full Reel	Reel Size
8-Pin MSOP	12 mm	8 mm	2500	13 in

#### Component Taping Orientation for 8-Pin SOIC (Narrow) Devices



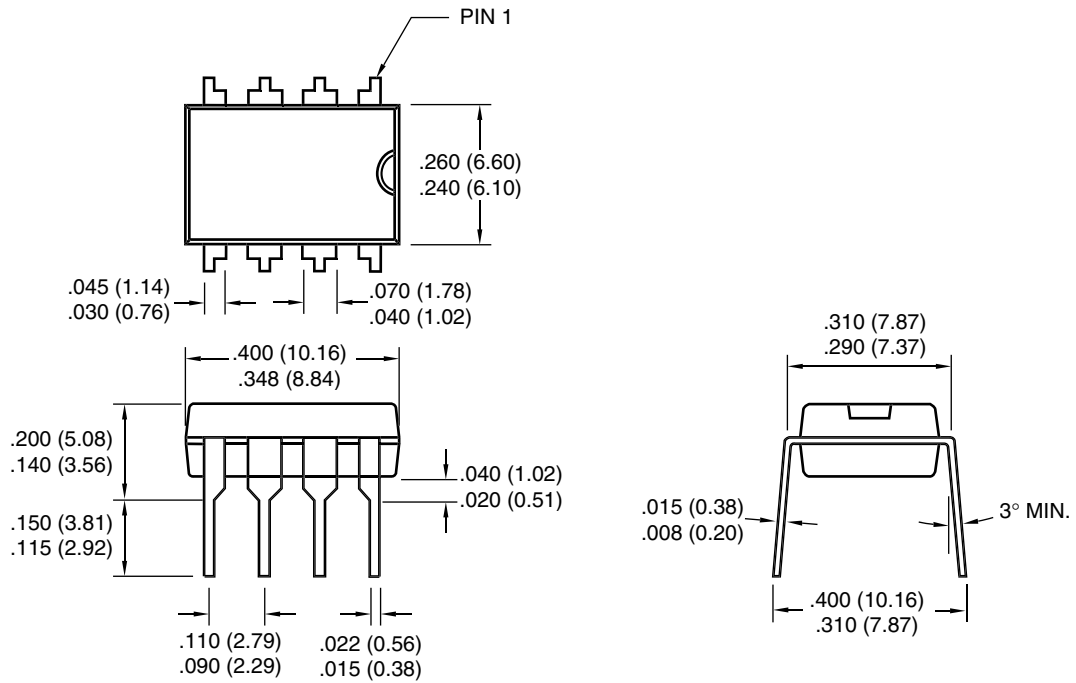
Standard Reel Component Orientation  
for TR Suffix Device

**Carrier Tape, Number of Components Per Reel and Reel Size**

Package	Carrier Width (W)	Pitch (P)	Part Per Full Reel	Reel Size
8-Pin SOIC (N)	12 mm	8 mm	2500	13 in

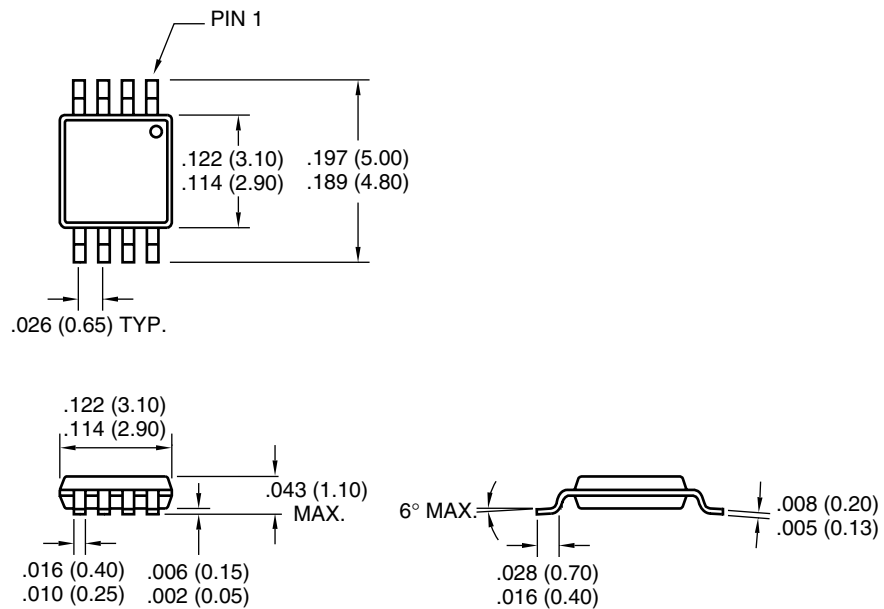
## 6.3 Package Dimensions

### 8-Pin Plastic DIP



Dimensions: inches (mm)

### 8-Pin MSOP

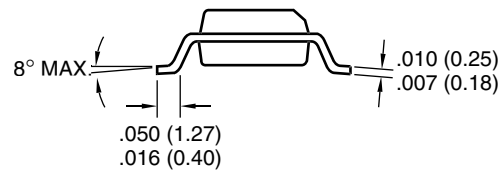
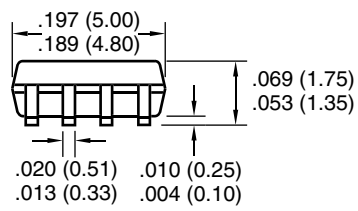
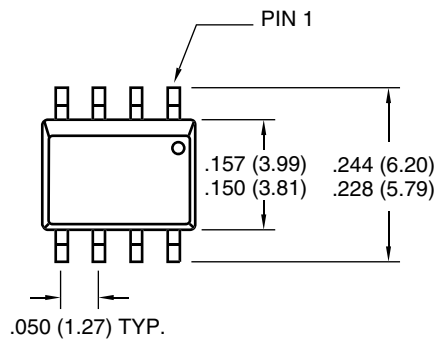


Dimensions: inches (mm)

# TC1026

## 6.3 Package Dimensions (Continued)

### 8-Pin SOIC



Dimensions: inches (mm)

## **Sales and Support**

### **Data Sheets**

Products supported by a preliminary Data Sheet may have an errata sheet describing minor operational differences and recommended workarounds. To determine if an errata sheet exists for a particular device, please contact one of the following:

1. Your local Microchip sales office
2. The Microchip Corporate Literature Center U.S. FAX: (480) 792-7277
3. The Microchip Worldwide Site ([www.microchip.com](http://www.microchip.com))

Please specify which device, revision of silicon and Data Sheet (include Literature #) you are using.

### **New Customer Notification System**

Register on our web site ([www.microchip.com/cn](http://www.microchip.com/cn)) to receive the most current information on our products.

# TC1026

---

NOTES:

Information contained in this publication regarding device applications and the like is intended through suggestion only and may be superseded by updates. It is your responsibility to ensure that your application meets with your specifications. No representation or warranty is given and no liability is assumed by Microchip Technology Incorporated with respect to the accuracy or use of such information, or infringement of patents or other intellectual property rights arising from such use or otherwise. Use of Microchip's products as critical components in life support systems is not authorized except with express written approval by Microchip. No licenses are conveyed, implicitly or otherwise, under any intellectual property rights.

## Trademarks


The Microchip name and logo, the Microchip logo, FilterLab, KEELOQ, microID, MPLAB, PIC, PICmicro, PICMASTER, PICSTART, PRO MATE, SEEVAL and The Embedded Control Solutions Company are registered trademarks of Microchip Technology Incorporated in the U.S.A. and other countries.

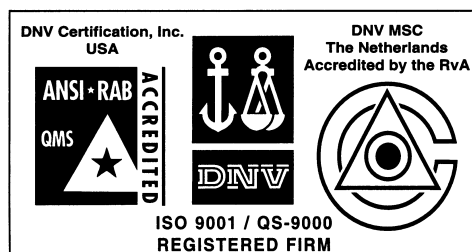
dsPIC, ECONOMONITOR, FanSense, FlexROM, fuzzyLAB, In-Circuit Serial Programming, ICSP, ICEPIC, microPort, Migratable Memory, MPASM, MPLIB, MPLINK, MPSIM, MXDEV, PICC, PICDEM, PICDEM.net, rfPIC, Select Mode and Total Endurance are trademarks of Microchip Technology Incorporated in the U.S.A.

Serialized Quick Turn Programming (SQTP) is a service mark of Microchip Technology Incorporated in the U.S.A.

All other trademarks mentioned herein are property of their respective companies.

© 2002, Microchip Technology Incorporated, Printed in the U.S.A., All Rights Reserved.

 Printed on recycled paper.



*Microchip received QS-9000 quality system certification for its worldwide headquarters, design and wafer fabrication facilities in Chandler and Tempe, Arizona in July 1999 and Mountain View, California in March 2002. The Company's quality system processes and procedures are QS-9000 compliant for its PICmicro® 8-bit MCUs, KEELOQ® code hopping devices, Serial EEPROMs, microperipherals, non-volatile memory and analog products. In addition, Microchip's quality system for the design and manufacture of development systems is ISO 9001 certified.*



# MICROCHIP

## WORLDWIDE SALES AND SERVICE

### AMERICAS

#### Corporate Office

2355 West Chandler Blvd.  
Chandler, AZ 85224-6199  
Tel: 480-792-7200 Fax: 480-792-7277  
Technical Support: 480-792-7627  
Web Address: <http://www.microchip.com>

#### Rocky Mountain

2355 West Chandler Blvd.  
Chandler, AZ 85224-6199  
Tel: 480-792-7966 Fax: 480-792-7456

#### Atlanta

500 Sugar Mill Road, Suite 200B  
Atlanta, GA 30350  
Tel: 770-640-0034 Fax: 770-640-0307

#### Boston

2 Lan Drive, Suite 120  
Westford, MA 01886  
Tel: 978-692-3848 Fax: 978-692-3821

#### Chicago

333 Pierce Road, Suite 180  
Itasca, IL 60143  
Tel: 630-285-0071 Fax: 630-285-0075

#### Dallas

4570 Westgrove Drive, Suite 160  
Addison, TX 75001  
Tel: 972-818-7423 Fax: 972-818-2924

#### Detroit

Tri-Atria Office Building  
32255 Northwestern Highway, Suite 190  
Farmington Hills, MI 48334  
Tel: 248-538-2250 Fax: 248-538-2260

#### Kokomo

2767 S. Albright Road  
Kokomo, Indiana 46902  
Tel: 765-864-8360 Fax: 765-864-8387

#### Los Angeles

18201 Von Karman, Suite 1090  
Irvine, CA 92612  
Tel: 949-263-1888 Fax: 949-263-1338

#### New York

150 Motor Parkway, Suite 202  
Hauppauge, NY 11788  
Tel: 631-273-5305 Fax: 631-273-5335

#### San Jose

Microchip Technology Inc.  
2107 North First Street, Suite 590  
San Jose, CA 95131  
Tel: 408-436-7950 Fax: 408-436-7955

#### Toronto

6285 Northam Drive, Suite 108  
Mississauga, Ontario L4V 1X5, Canada  
Tel: 905-673-0699 Fax: 905-673-6509

### ASIA/PACIFIC

#### Australia

Microchip Technology Australia Pty Ltd  
Suite 22, 41 Rawson Street  
Epping 2121, NSW  
Australia  
Tel: 61-2-9868-6733 Fax: 61-2-9868-6755

#### China - Beijing

Microchip Technology Consulting (Shanghai)  
Co., Ltd., Beijing Liaison Office  
Unit 915  
Bei Hai Wan Tai Bldg.  
No. 6 Chaoyangmen Beidajie  
Beijing, 100027, No. China  
Tel: 86-10-85282100 Fax: 86-10-85282104

#### China - Chengdu

Microchip Technology Consulting (Shanghai)  
Co., Ltd., Chengdu Liaison Office  
Rm. 2401, 24th Floor,  
Ming Xing Financial Tower  
No. 88 TIDU Street  
Chengdu 610016, China  
Tel: 86-28-6766200 Fax: 86-28-6766599

#### China - Fuzhou

Microchip Technology Consulting (Shanghai)  
Co., Ltd., Fuzhou Liaison Office  
Unit 28F, World Trade Plaza  
No. 71 Wusi Road  
Fuzhou 350001, China  
Tel: 86-591-7503506 Fax: 86-591-7503521

#### China - Shanghai

Microchip Technology Consulting (Shanghai)  
Co., Ltd.  
Room 701, Bldg. B  
Far East International Plaza  
No. 317 Xian Xia Road  
Shanghai, 200051  
Tel: 86-21-6275-5700 Fax: 86-21-6275-5060

#### China - Shenzhen

Microchip Technology Consulting (Shanghai)  
Co., Ltd., Shenzhen Liaison Office  
Rm. 1315, 13/F, Shenzhen Kerry Centre,  
Renminnan Lu  
Shenzhen 518001, China  
Tel: 86-755-2350361 Fax: 86-755-2366086

#### Hong Kong

Microchip Technology Hongkong Ltd.  
Unit 901-6, Tower 2, Metroplaza  
223 Hing Fong Road  
Kwai Fong, N.T., Hong Kong  
Tel: 852-2401-1200 Fax: 852-2401-3431

#### India

Microchip Technology Inc.  
India Liaison Office  
Divyasree Chambers  
1 Floor, Wing A (A3/A4)  
No. 11, O'Shaugnessey Road  
Bangalore, 560 025, India  
Tel: 91-80-2290061 Fax: 91-80-2290062

### Japan

Microchip Technology Japan K.K.  
Benex S-1 6F  
3-18-20, Shinyokohama  
Kohoku-Ku, Yokohama-shi  
Kanagawa, 222-0033, Japan  
Tel: 81-45-471-6166 Fax: 81-45-471-6122

### Korea

Microchip Technology Korea  
168-1, Youngbo Bldg. 3 Floor  
Samsung-Dong, Kangnam-Ku  
Seoul, Korea 135-882  
Tel: 82-2-554-7200 Fax: 82-2-558-5934

### Singapore

Microchip Technology Singapore Pte Ltd.  
200 Middle Road  
#07-02 Prime Centre  
Singapore, 188980  
Tel: 65-6334-8870 Fax: 65-6334-8850

### Taiwan

Microchip Technology Taiwan  
11F-3, No. 207  
Tung Hua North Road  
Taipei, 105, Taiwan  
Tel: 886-2-2717-7175 Fax: 886-2-2545-0139

### EUROPE

#### Denmark

Microchip Technology Nordic ApS  
Regus Business Centre  
Lautrup høj 1-3  
Ballerup DK-2750 Denmark  
Tel: 45 4420 9895 Fax: 45 4420 9910

#### France

Microchip Technology SARL  
Parc d'Activite du Moulin de Massy  
43 Rue du Saule Trapu  
Batiment A - 1er Etage  
91300 Massy, France  
Tel: 33-1-69-53-63-20 Fax: 33-1-69-30-90-79

#### Germany

Microchip Technology GmbH  
Gustav-Heinemann Ring 125  
D-81739 Munich, Germany  
Tel: 49-89-627-144 0 Fax: 49-89-627-144-44

#### Italy

Microchip Technology SRL  
Centro Direzionale Colleoni  
Palazzo Taurus 1 V. Le Colleoni 1  
20041 Agrate Brianza  
Milan, Italy  
Tel: 39-039-65791-1 Fax: 39-039-6899883

#### United Kingdom

Arizona Microchip Technology Ltd.  
505 Eskdale Road  
Winnersh Triangle  
Wokingham  
Berkshire, England RG41 5TU  
Tel: 44 118 921 5869 Fax: 44-118 921-5820

03/01/02

