

2.4-2.5 GHz / 4.9-5.8 GHz Dual-Band Power Amplifier

SST13LP02



Data Sheet

Features:

- **High Gain:**
 - Typically 27-28 dB gain across 2.4-2.5 GHz
 - Typically 30-34 dB gain across 4.9-5.8 GHz
- **High linear output power:**
 - >25 dBm P1dB (Pulsed single-tone signal) across 2.4-2.5 GHz
 - Meets 802.11b OFDM ACPR requirement up to 21.5 dBm across 2.4-2.5 GHz
 - Meets 802.11g OFDM ACPR requirement up to 22 dBm across 2.4-2.5 GHz
 - Added EVM~4% up to 19 dBm for 54 Mbps 802.11g signal across 2.4-2.5 GHz
 - >25 dBm P1dB (Pulsed single-tone signal) across 4.9-5.8 GHz
 - Meets 802.11a OFDM ACPR requirement up to 22 dBm across 4.9-5.8GHz
 - Added EVM~4% up to 18 dBm for 54 Mbps 802.11a signal across 4.9-5.8GHz
- **High power-added efficiency/Low operating current for 802.11a/b/g applications**
 - ~220 mA @ P_{OUT} = 22 dBm for 802.11g
 - ~205 mA @ P_{OUT} = 21.5 dBm for 802.11b
 - ~380 mA @ P_{OUT} = 22 dBm for 802.11a
- **Built-in Ultra-low I_{REF} power-up/down control**
 - I_{REF} <2 mA
- **Low idle current**
 - ~55 mA I_{CQ} (802.11b/g)
 - ~135 mA I_{CQ} (802.11a)
- **High-speed power-up/down**
 - Turn on/off time (10%-90%) <100 ns
 - Typical power-up/down delay with driver delay included <200 ns
- **High temperature stability**
 - ~2/1 dB gain/power variation between 0°C to +85°C across 2.4-2.5 GHz
 - ~8/2 dB gain/max linear power variation between 0°C to +85°C across 4.9-5.8 GHz
 - ~1 dB detector variation over 0°C to +85°C
- **Low shut-down current (< 0.1 μA)**
- **On-chip power detection**
- **20 dB dynamic range on-chip power detection**
- **Simple input/output matching**
- **Packages available**
 - 24-lead WQFN (4mm x 4mm)
 - Non-Pb (lead-free) packages available

Applications:

- **WLAN (IEEE 802.11a/g/b)**
- **Japanese WLAN**
- **HyperLAN2**
- **Multimedia**
- **Home RF**
- **Cordless phones**

Product Description

The SST13LP02 is a high-efficiency, dual-band power amplifier based on the highly-reliable InGaP/GaAs HBT technology.

The SST13LP02 can be easily configured for high-power applications with superb power-added efficiency while operating over the 802.11a/b/g frequency band for U.S., European, and Japanese markets (2.4-2.5 GHz and 4.9-5.8 GHz).

The SST13LP02 has excellent linearity, typically ~4% added EVM at 19 dBm output power, which is essential for 54 Mbps 802.11g operation while meeting 802.11g spectrum mask at 22 dBm and 802.11b spectrum mask at 21.5 dBm. For 802.11a operation, the SST13LP02 has demonstrated typically ~4% added EVM at 18 dBm output power while meeting 802.11a spectrum mask at 22 dBm. The

SST13LP02 also has wide-range (>15 dB), temperature-stable (~1.5 dB over 85°C), single-ended power detectors which lower users' cost on power control.

The power amplifier IC also features easy board-level usage along with high-speed power-up/down control. Ultra-low reference current (total I_{REF} <2 mA) makes the SST13LP02 controllable by an on/off switching signal directly from the baseband chip. These features, coupled with low operating current, make the SST13LP02 ideal for the final stage power amplification in both battery-powered 802.11a/b/g WLAN transmitters and access point applications.

The SST13LP02 is offered in a 24-contact WQFN package. See Figure 2 for pin assignments and Table 1 for pin descriptions.



2.4-2.5 GHz / 4.9-5.8 GHz Dual-Band Power Amplifier SST13LP02

Data Sheet

Functional Blocks

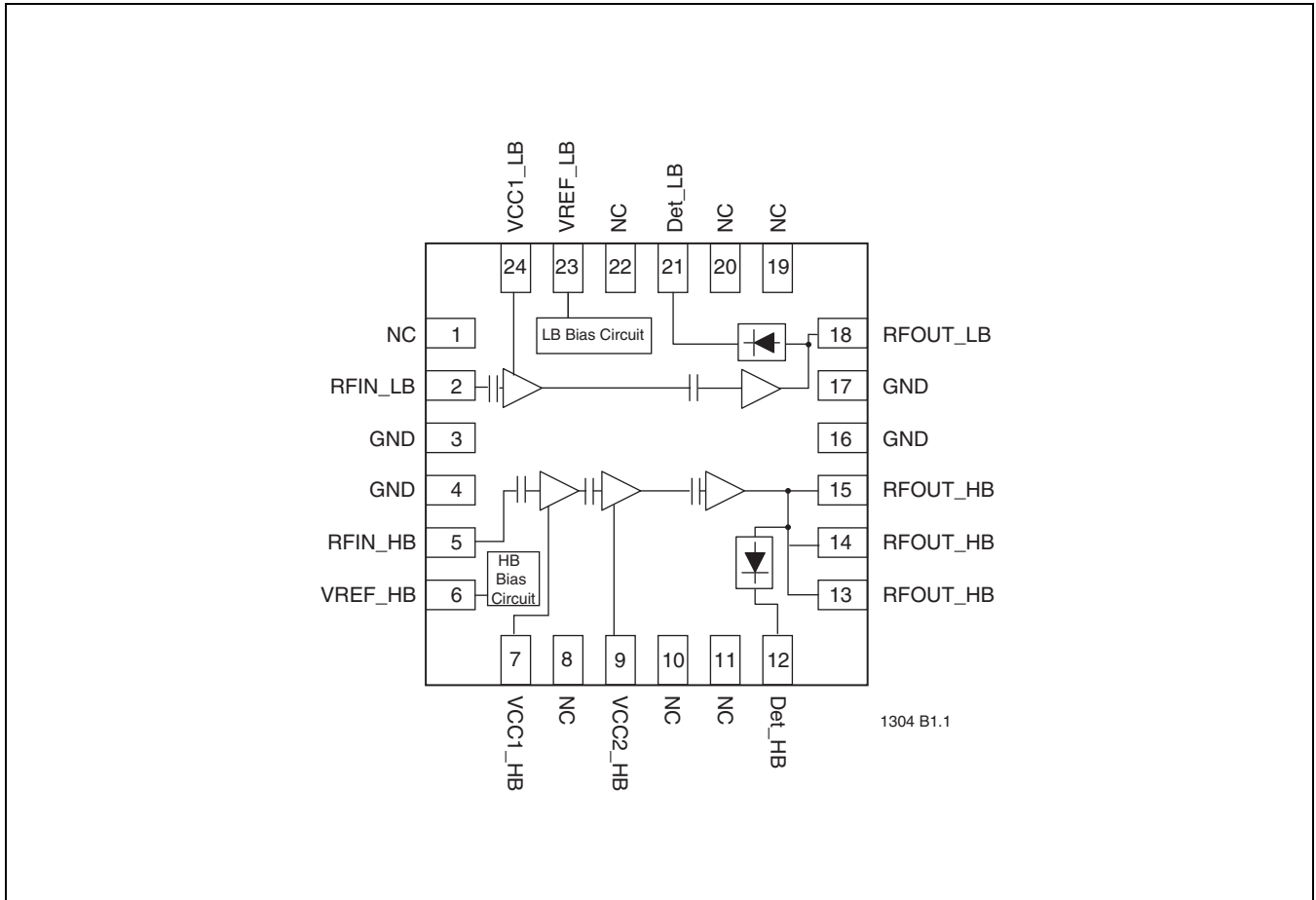

FIGURE 1: Functional Block Diagram

Pin Assignments

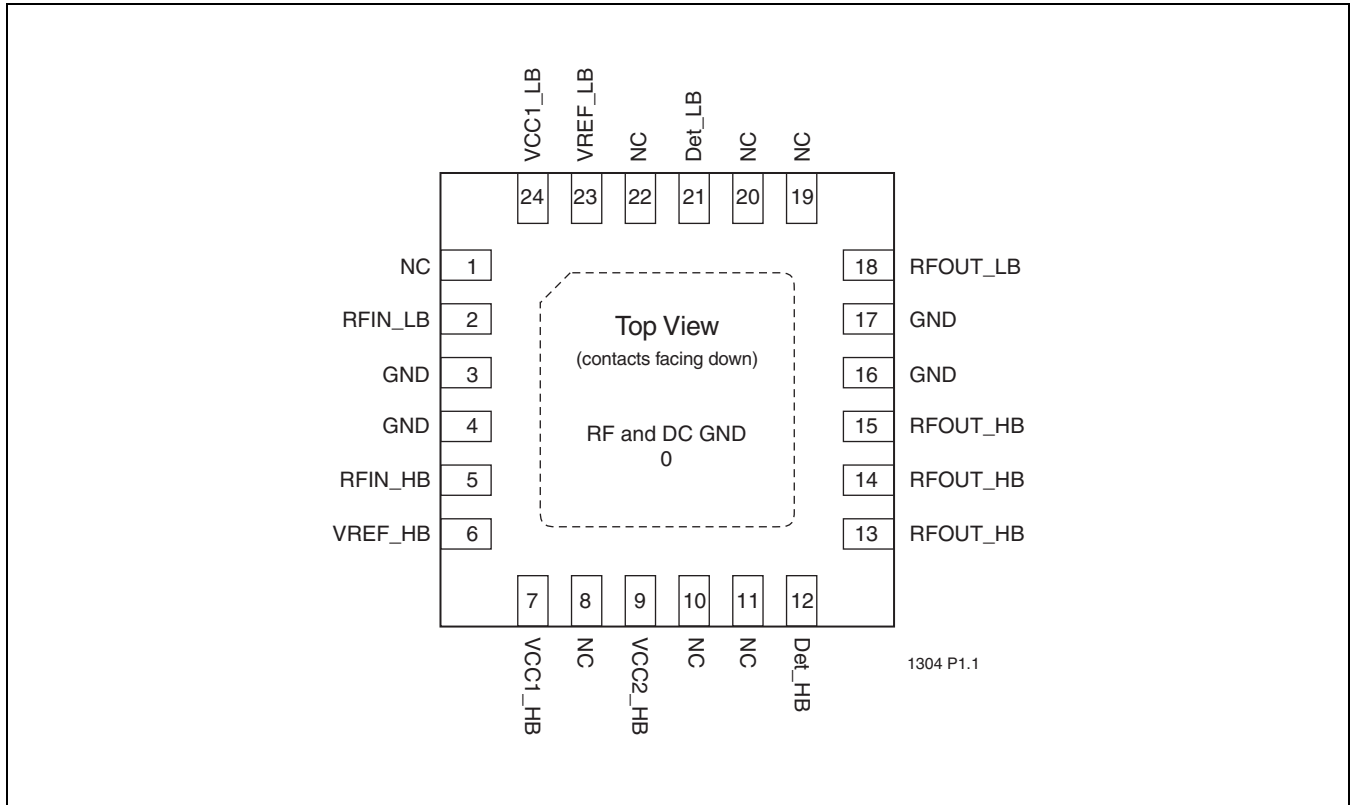

FIGURE 2: Pin Assignments for 16-contact WQFN



2.4-2.5 GHz / 4.9-5.8 GHz Dual-Band Power Amplifier SST13LP02

Data Sheet

Pin Descriptions

TABLE 1: Pin Description

Symbol	Pin No.	Pin Name	Type	Function
GND	0	Ground		Ground Pad
NC	1	No Connection		Unconnected Pin
RFin_LB	2		I	RF Input for Low Band, DC decoupled
GND	3	Ground		Ground Pin
GND	4	Ground		Ground Pin
RFin_HB	5		I	RF Input for High Band, DC decoupled
V _{REF_HB}	6	Power Supply	PWR	Idle Current Control for High Band
V _{cc1_HB}	7	Power Supply	PWR	Vcc Power Supply for High Band
NC	8	No Connection		Unconnected Pin
V _{cc2_HB}	9	Power Supply	PWR	Vcc Power Supply for High Band
NC	10	No Connection		Unconnected Pin
NC	11	No Connection		Unconnected Pin
Det_HB	12		O	Detector Voltage Output for High Band
RFout_HB	13	Power Supply	O/PWR	RF Output/Vcc power supply for High Band
RFout_HB	14	Power Supply	O/PWR	RF Output/Vcc power supply for High Band
RFout_HB	15	Power Supply	O/PWR	RF Output/Vcc power supply for High Band
GND	16	Ground		Ground Pin
GND	17	Ground		Ground Pin
RFout_LB	18	Power Supply	O/PWR	RF Output/Vcc power supply for Low Band
NC	19	No Connection		Unconnected Pin
NC	20	No Connection		Unconnected Pin
Det_LB	21		O	Detector Voltage Output for Low Band
NC	22	No Connection		Unconnected Pin
V _{REF_LB}	23	Power Supply	PWR	Idle Current Control for Low Band
V _{cc1_LB}	24	Power Supply	PWR	Vcc Power Supply for Low Band

T1.2 1304



2.4-2.5 GHz / 4.9-5.8 GHz Dual-Band Power Amplifier SST13LP02

Data Sheet

ELECTRICAL SPECIFICATIONS

The AC and DC specifications for the power amplifier interface signals. Refer to Tables 2 and 4 for the DC voltage and current specifications. Refer to Figures 3 through 22 for the RF performance.

Absolute Maximum Stress Ratings Applied conditions greater than those listed under “Absolute Maximum Stress Ratings” may cause permanent damage to the device. This is a stress rating only and functional operation of the device at these conditions or conditions greater than those defined in the operational sections of this data sheet is not implied. Exposure to absolute maximum stress rating conditions may affect device reliability.

Supply Voltage (V_{CC})	-0.3V to +4.0V
Reference Voltage (V_{REF})	-0.3V to +3.3V
DC supply current (I_{CC})	500 mA
Operating Temperature (T_A)	-40°C to +85°C
Storage Temperature (T_{STG})	-40°C to +120°C
Maximum Junction Temperature (T_J)	+150°C



2.4-2.5 GHz / 4.9-5.8 GHz Dual-Band Power Amplifier SST13LP02

Data Sheet

For 802.11b/g Operation

TABLE 2: DC Electrical Characteristics

Symbol	Parameter	Min.	Typ	Max.	Unit	Test Conditions
V _{CC}	Supply Voltage	3.0	3.3	3.6	V	
I _{CC}	Supply Current for 802.11g, 22 dBm for 802.11b, 21.5 dBm		220		mA	
			205		mA	
I _{CQ}	Idle current for 802.11g to meet EVM<4% @ 18 dBm		55		mA	
I _{OFF}	Shut down current			0.1	μA	
V _{REG}	Reference Voltage with drop resistors		2.9		V	

T2.1 1304

TABLE 3: AC Electrical Characteristics for Configuration

Symbol	Parameter	Min.	Typ	Max.	Unit
F _{L-U}	Frequency range	2400		2485	MHz
G	Small signal gain	25			dB
G _{VAR1}	Gain variation over band (2400-2485 MHz)			±0.5	dB
G _{VAR2}	Gain ripple over channel (20 MHz)		0.2		dB
ACPR	Output power level meet 11b spectrum mask	21			dBm
	Output power level meet 11g OFDM 54 Mbps spectrum mask	21			dBm
Added EVM	Added EVM @ Pout = 19 dBm with (54 Mbps 11g OFDM)			4	%
2f	2nd Harmonics at Pout=18 dBm (54 Mbps 11g OFDM)		-45		dBc
3f	3rd Harmonics at Pout=18 dBm (54 Mbps 11g OFDM)		-50		dBc
ACPR1	Adjacent Channel Power Rejection at Pout=18 dBm (54 Mbps 11g OFDM)		-35		dBc
ACPR2	Alt. Adjacent Channel Power Rejection at Pout=18 dBm (54 Mbps 11g OFDM)		-45		dBc

T3.1 1304



2.4-2.5 GHz / 4.9-5.8 GHz Dual-Band Power Amplifier SST13LP02

Data Sheet

For 802.11a Operation

TABLE 4: DC Electrical Characteristics

Symbol	Parameter	Min.	Typ	Max.	Unit
V _{CC}	Supply Voltage	3.0	3.3	3.6	V
I _{CC}	Supply Current for 802.11a, 22 dBm at V _{CC} = 3.3V		380		mA
I _{CO}	V _{CC} quiescent current		135		mA
I _{OFF}	Shut down current			1.0	μA
V _{REG}	Reference Voltage with drop resistors		2.9		V
Total I _{REG}	Total Reference Current			2	mA

T4.1 1304

TABLE 5: AC Electrical Characteristics for Configuration

Symbol	Parameter	Min.	Typ	Max.	Unit
F _{L-U}	Frequency range	4920		5805	MHz
G	Small signal gain across 4.9~5.8GHz	26			dB
G _{VAR}	Gain variation over band (4.9-5.8 MHz)		5.0		dB
	Gain variation over band (4.9-5.35 MHz)		1.0		dB
	Gain variation over band (5.7-5.8 MHz)		1.0		dB
	Gain variation over channel (20 MHz)		0.2		dB
Added EVM	Added EVM @ P _{out} =18 dBm (54 Mbps 11a OFDM)			4	%
ACPR	Output power level with 802.11a mask compliance across 4.9-5.8 GHz	21			dBm
2f	2nd Harmonics at P _{out} =18 dBm (54 Mbps 11a OFDM)		-45		dBc
3f	3rd Harmonics at P _{out} =18 dBm (54 Mbps 11a OFDM)		-50		dBc
ACPR1	Adjacent Channel Power Rejection at P _{out} =18 dBm (54 Mbps 11a OFDM)		-35		dBc
ACPR2	Alt. Adjacent Channel Power Rejection at P _{out} =18 dBm (54 Mbps 11a OFDM)		-50		dBc

T5.1 1304



2.4-2.5 GHz / 4.9-5.8 GHz Dual-Band Power Amplifier SST13LP02

Data Sheet

Typical Low Band Performance for 802.11B/G

TEST CONDITIONS: $V_{CC} = 3.3V$, $T_A = 25^\circ C$, $V_{REF_LB} = 2.9V$ UNLESS OTHERWISE NOTED

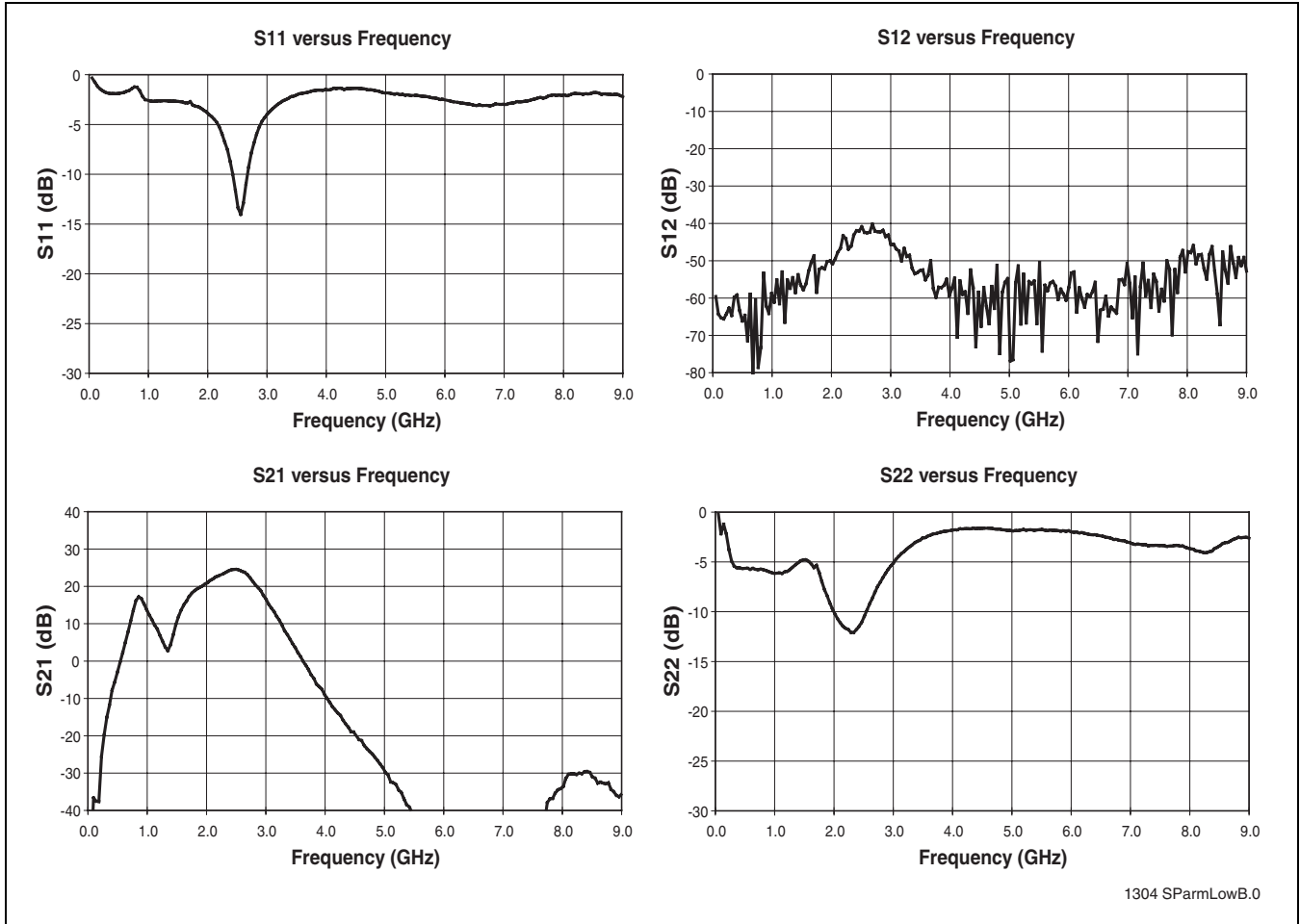

FIGURE 3: Low Band S-Parameters

Test Conditions: VCC = 3.3V, 54 Mbps 802.11g OFDM signal

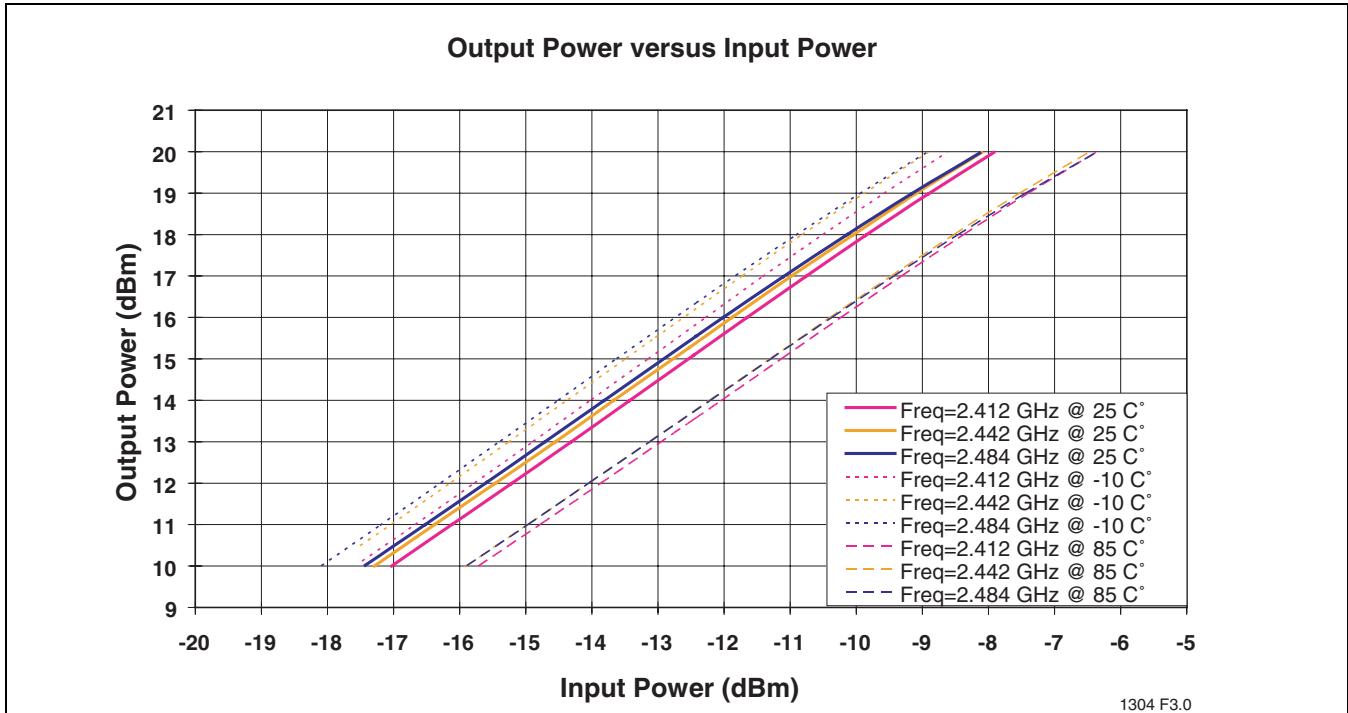

FIGURE 4: Low Band Output Power Versus Input Power

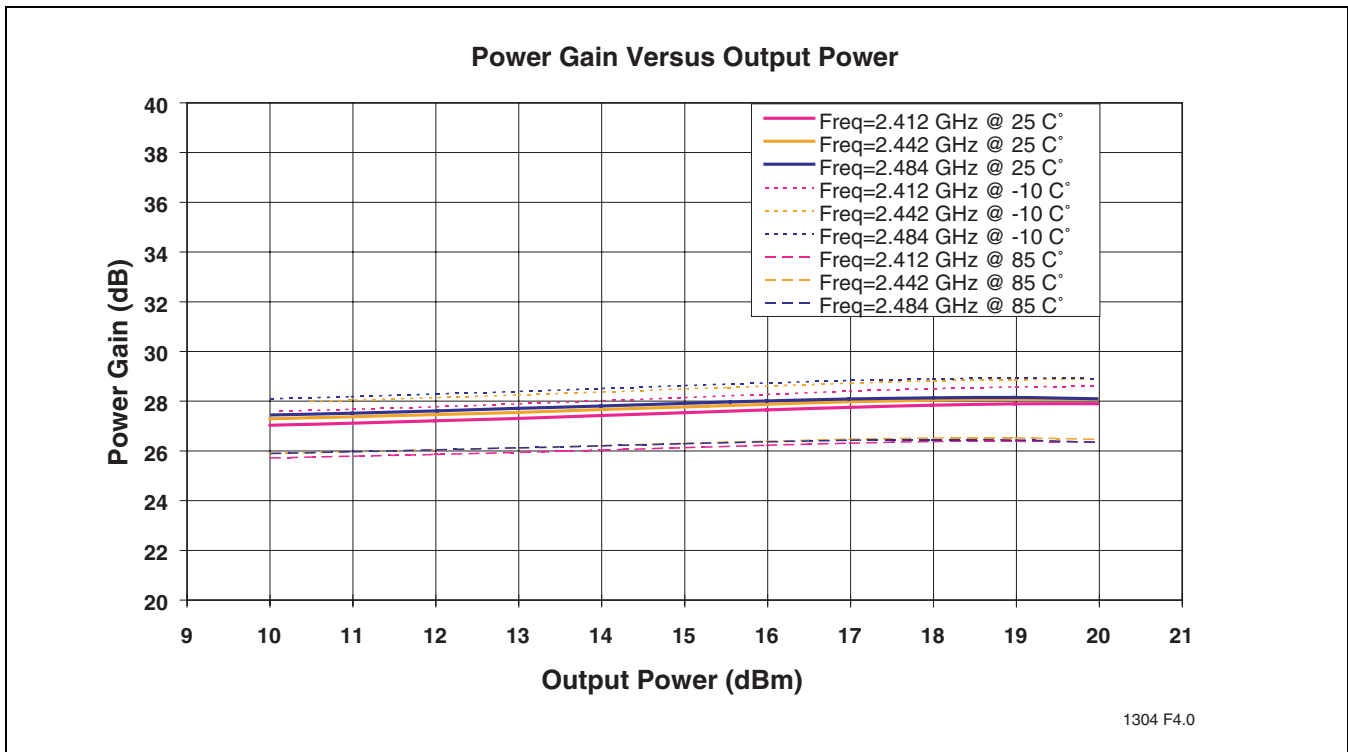

FIGURE 5: Low Band Power Gain versus Output Power

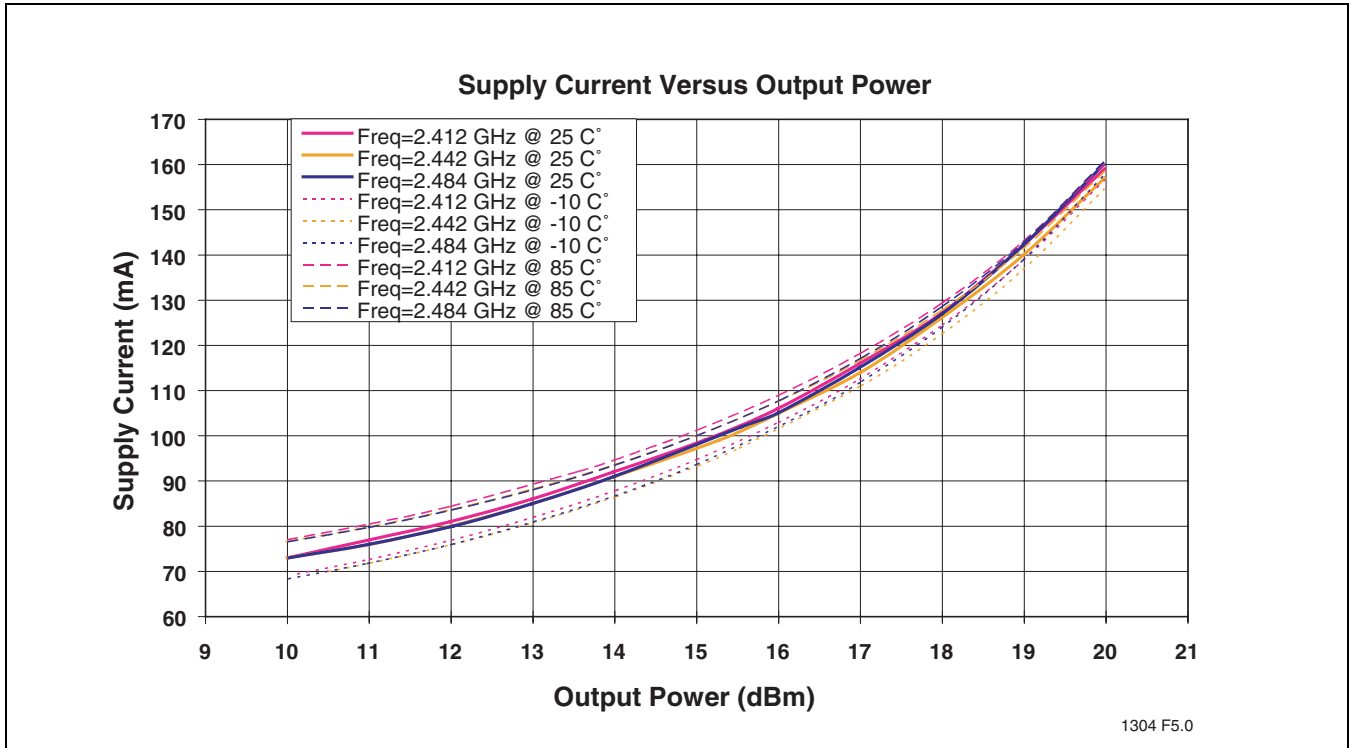

FIGURE 6: Low Band Supply Current versus Output Power

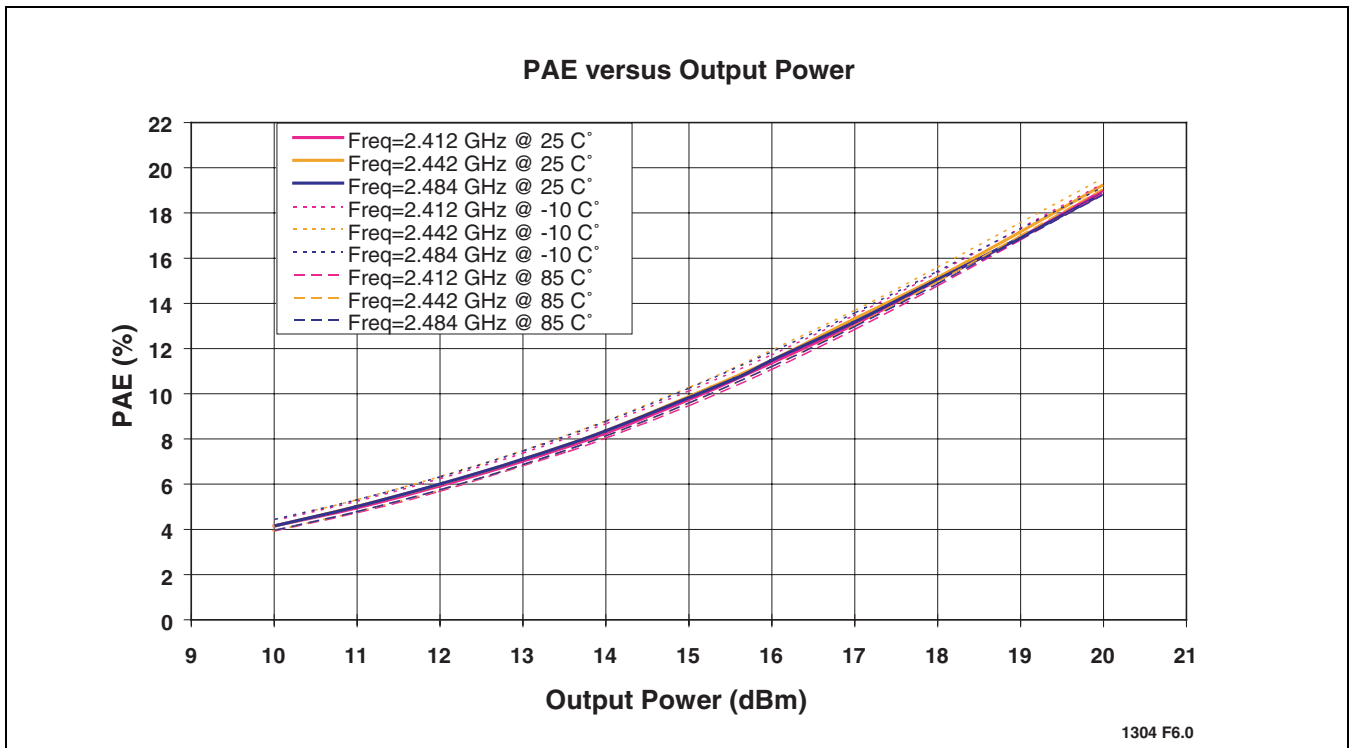

FIGURE 7: Low Band PAE versus Output Power

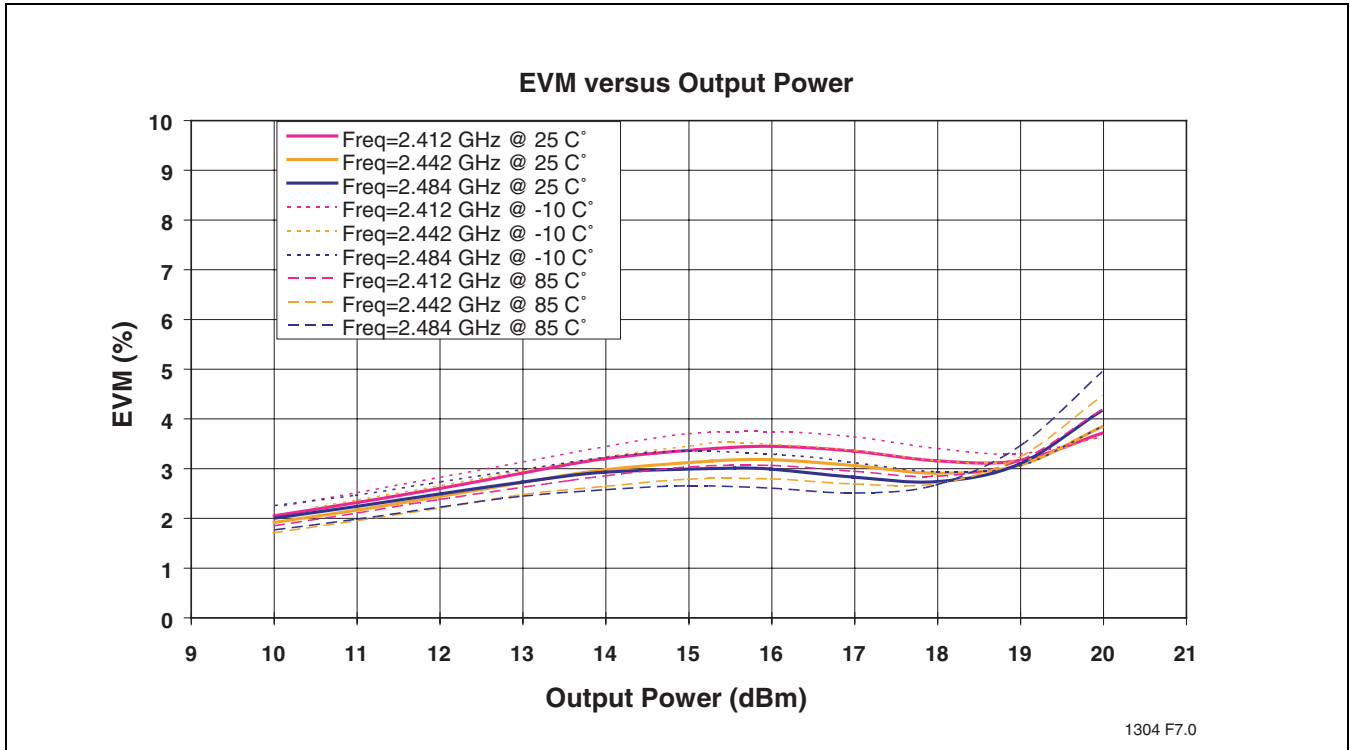

FIGURE 8: Low Band EMV Versus Output Power

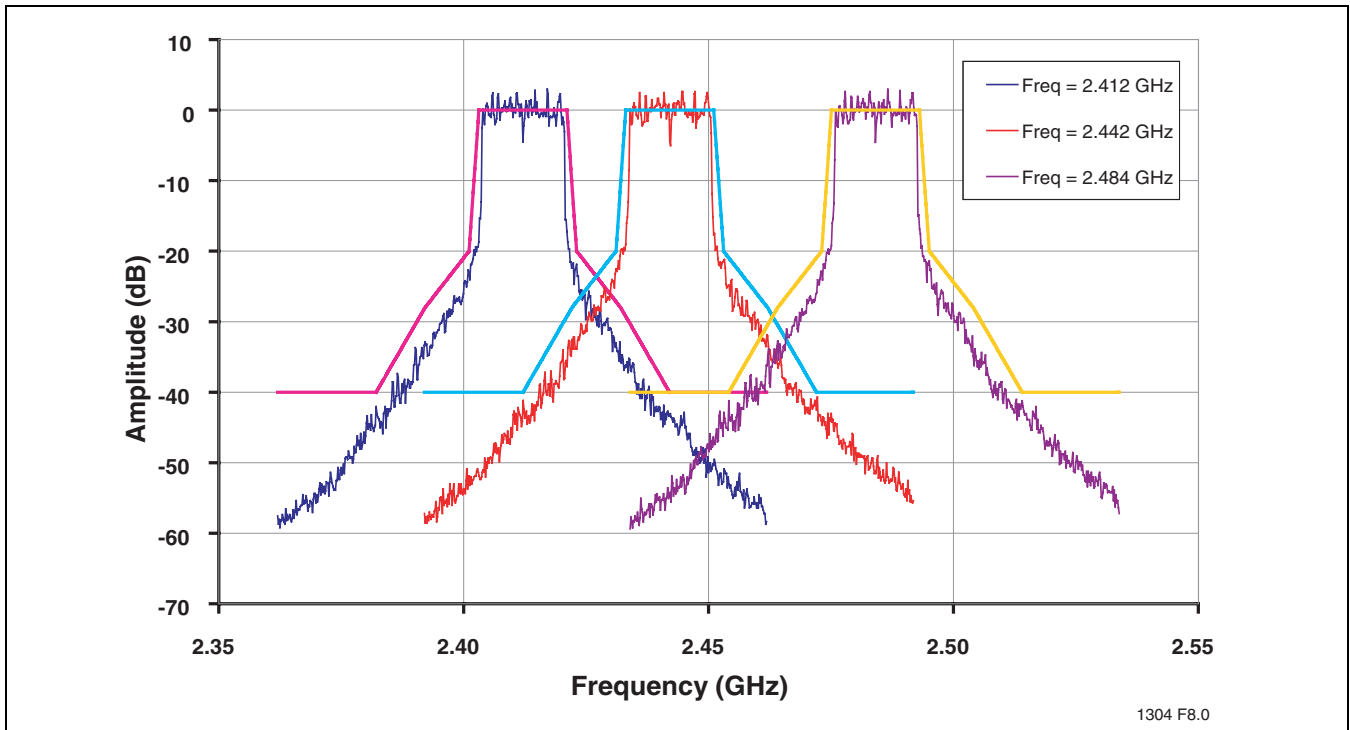

FIGURE 9: Low Band 802.11b Spectrum Mask at 22 dBm with DC Current of 220 mA



2.4-2.5 GHz / 4.9-5.8 GHz Dual-Band Power Amplifier SST13LP02

Data Sheet

Test Conditions: VCC = 3.3V, TA = 25°C, 1 Mbps 802.11b CCK Signal

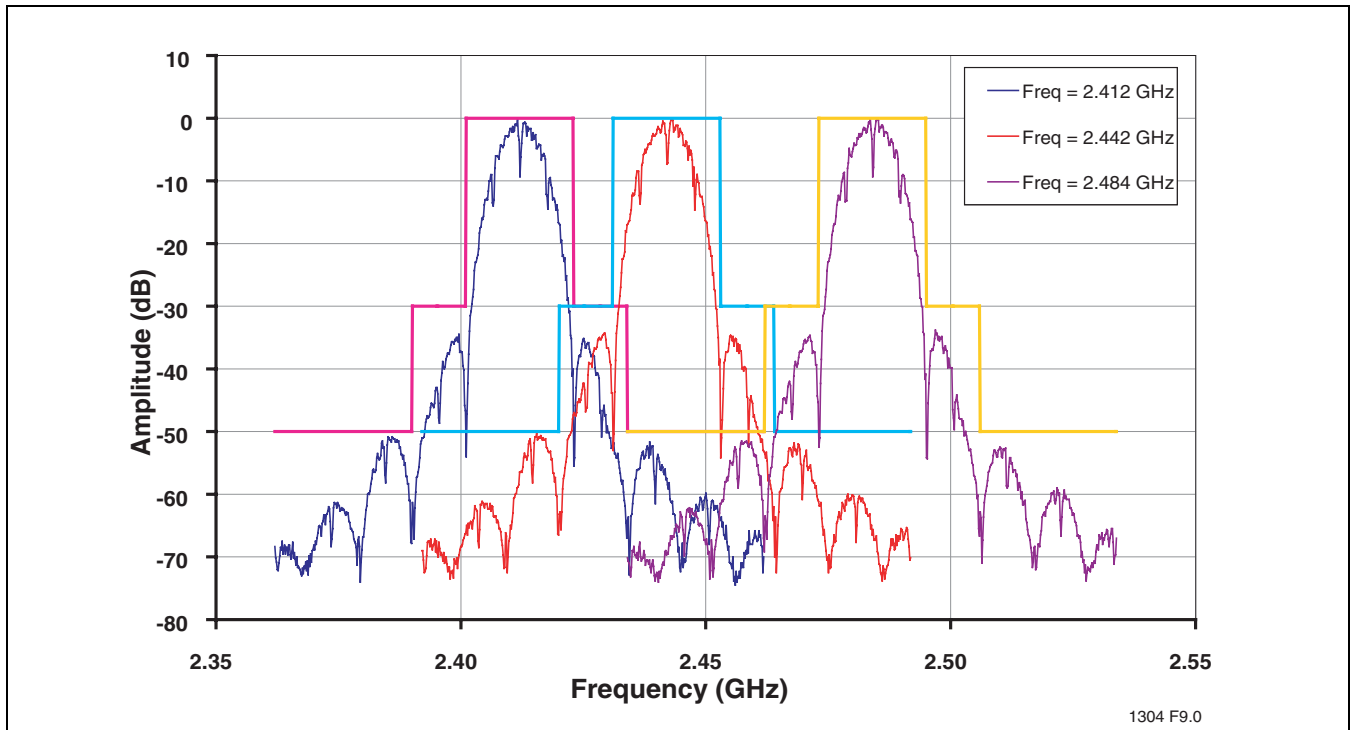

FIGURE 10: Low Band 802.11b Spectrum Mask at 21.5 dBm with DC Current of 205 mA

Low Band Power Detector characteristics

Test Conditions: VCC = 3.3V, VREG_LB = 2.85V, TA = 25°C, 54 Mbps 802.11g OFDM Signal

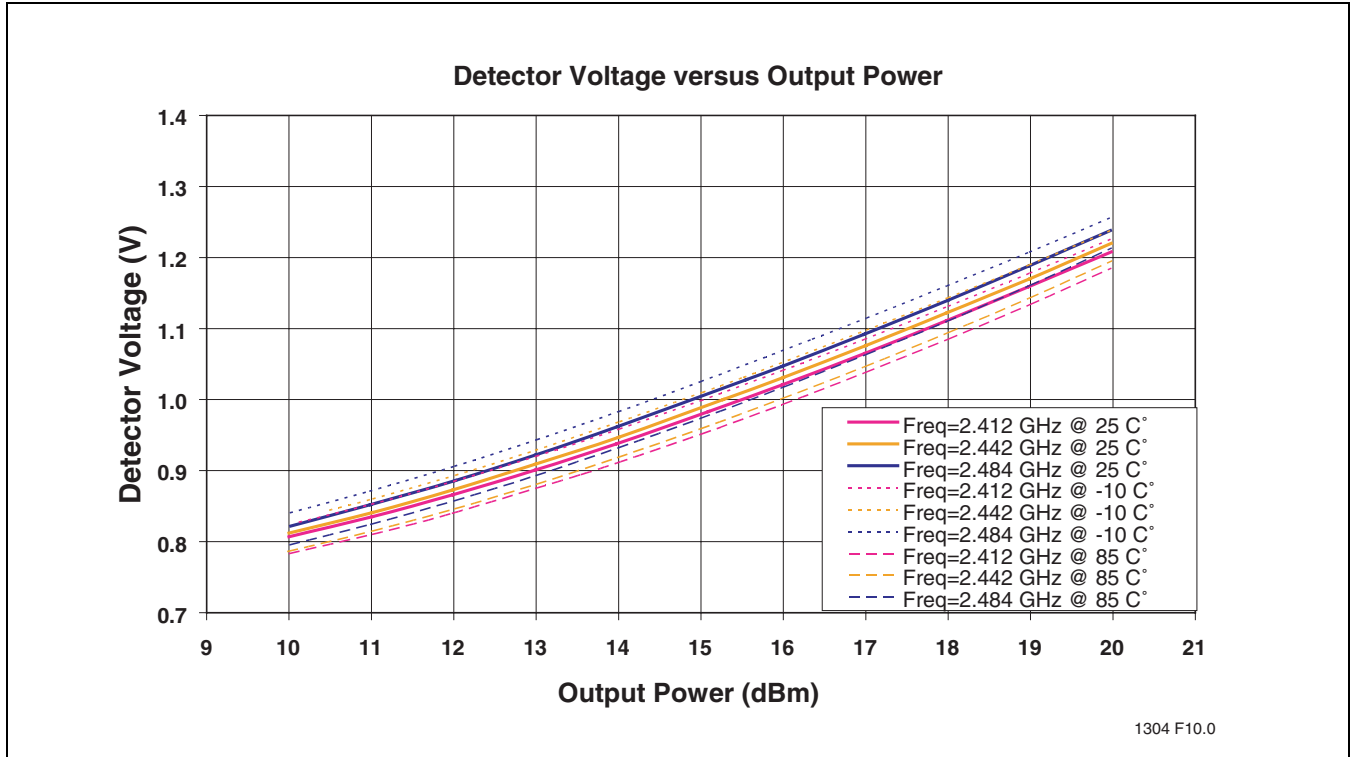

FIGURE 11: Low Band Detector Voltage versus output power



2.4-2.5 GHz / 4.9-5.8 GHz Dual-Band Power Amplifier SST13LP02

Data Sheet

Typical High Band Performance for 802.11a

Test Conditions: $V_{CC} = 3.3V$, $T_A = 25^{\circ}C$, $V_{REF_HB} = 2.9V$ unless otherwise noted

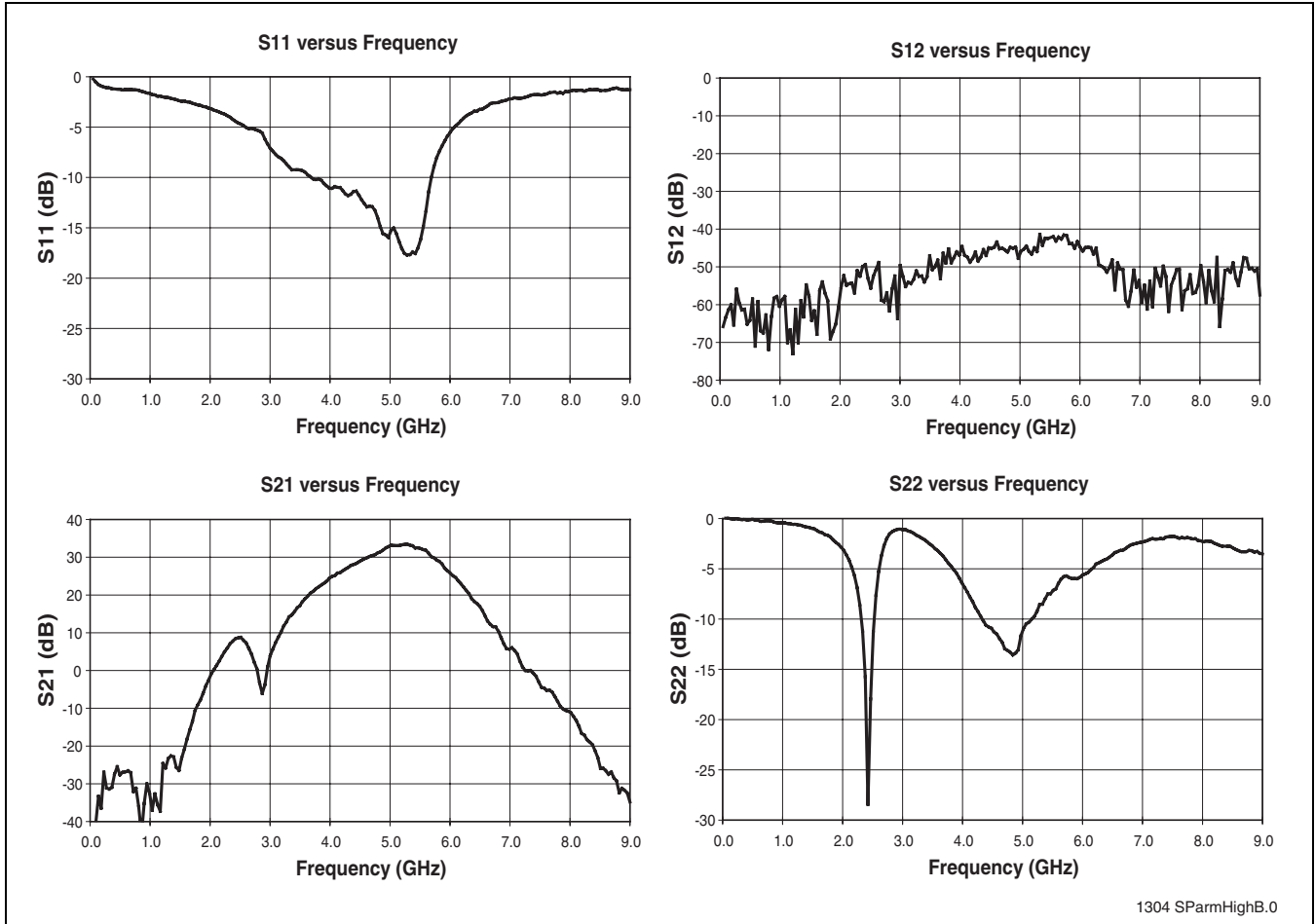

FIGURE 12: High Band S-Parameters

2.4-2.5 GHz / 4.9-5.8 GHz Dual-Band Power Amplifier SST13LP02



Data Sheet

Typical Performance characteristics for 802.11A
Test Conditions: VCC = 3.3V, 54 Mbps 802.11a OFDM Signal

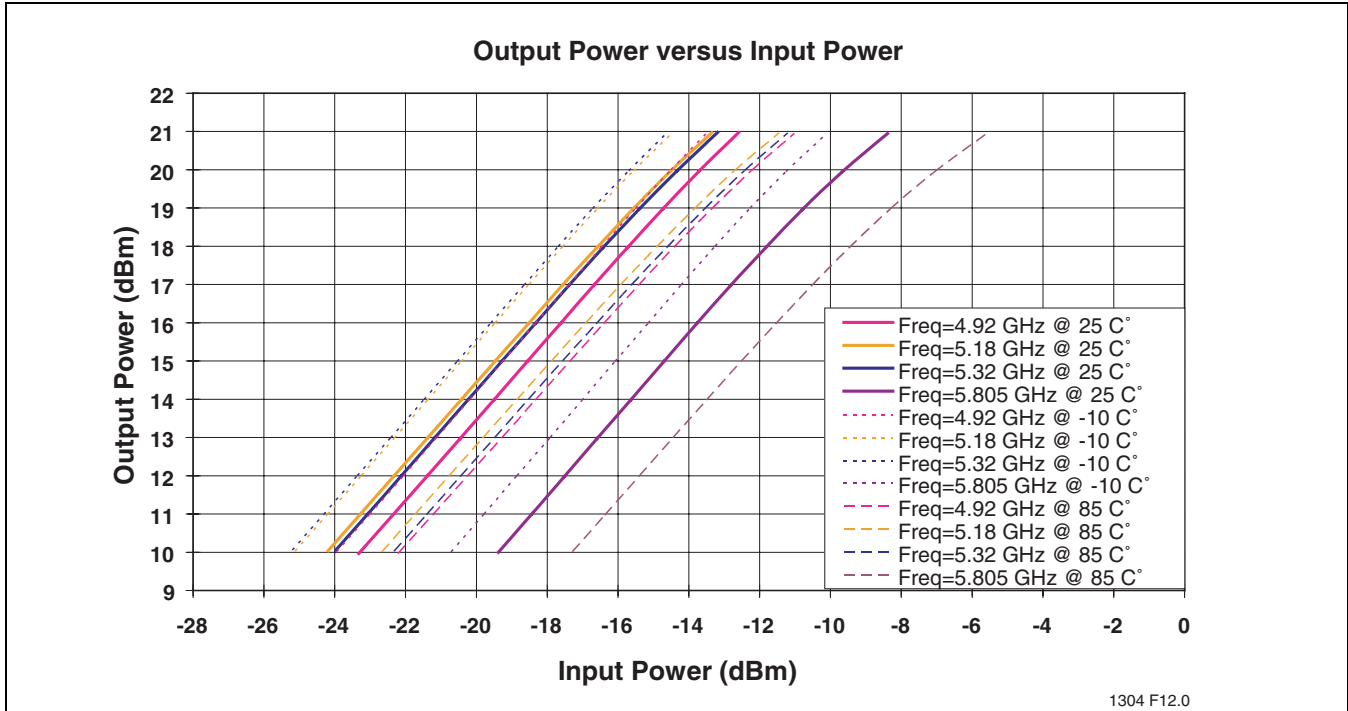

FIGURE 13: High Band Output Power Versus Input Power

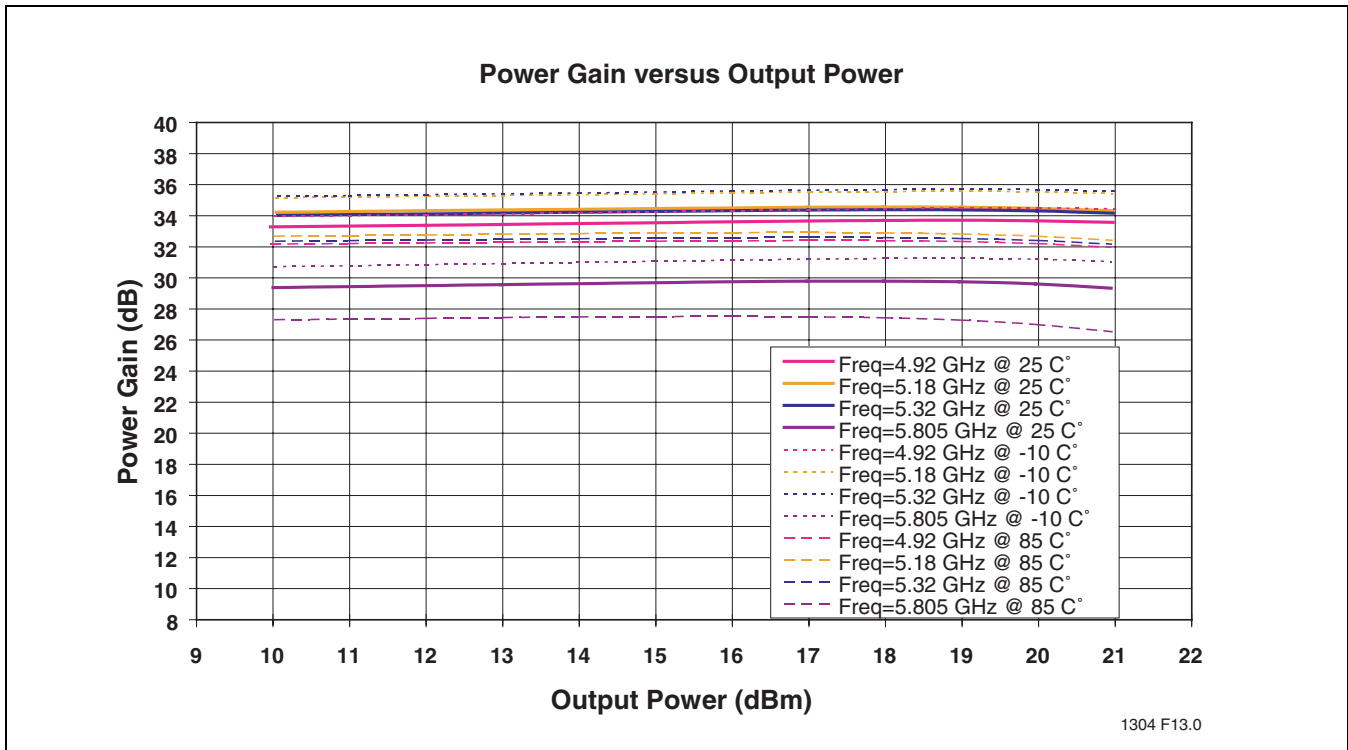

FIGURE 14: High Band Power Gain versus Output Power

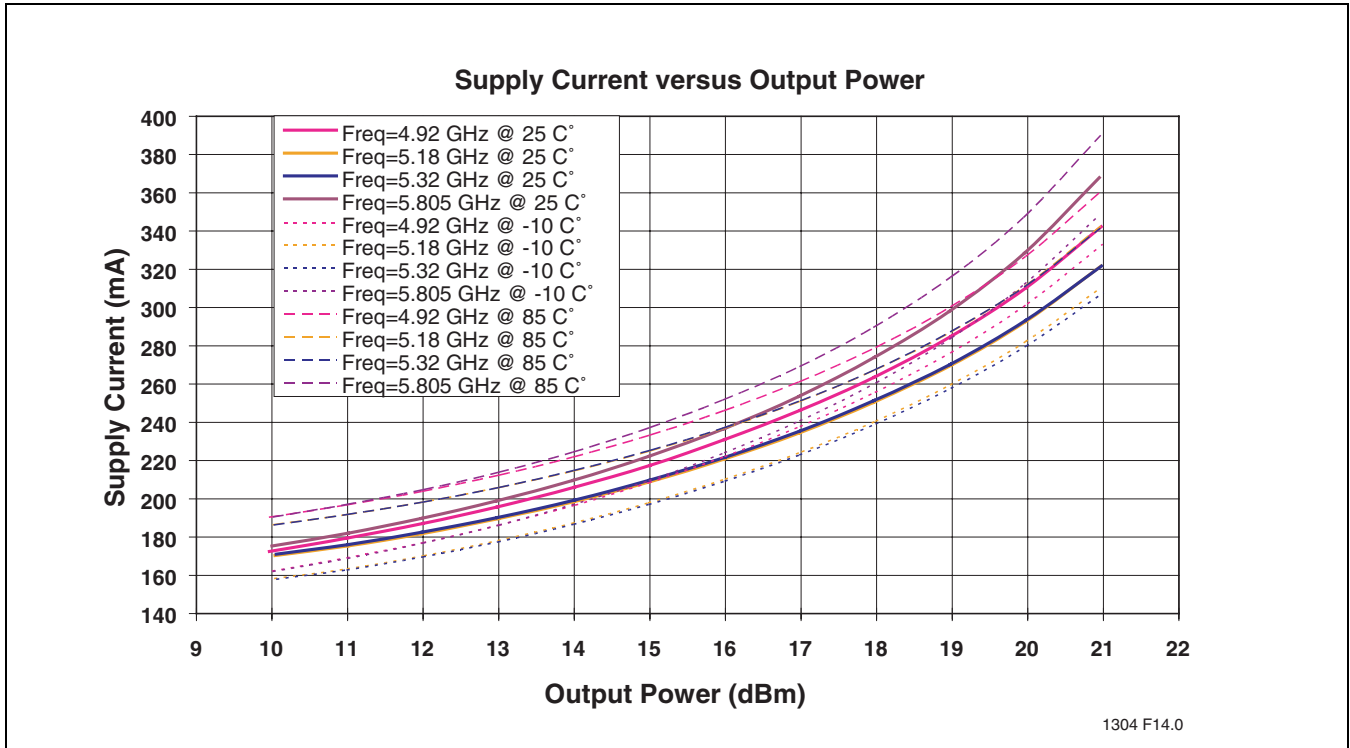

FIGURE 15: High Band Supply Current Versus Output Power

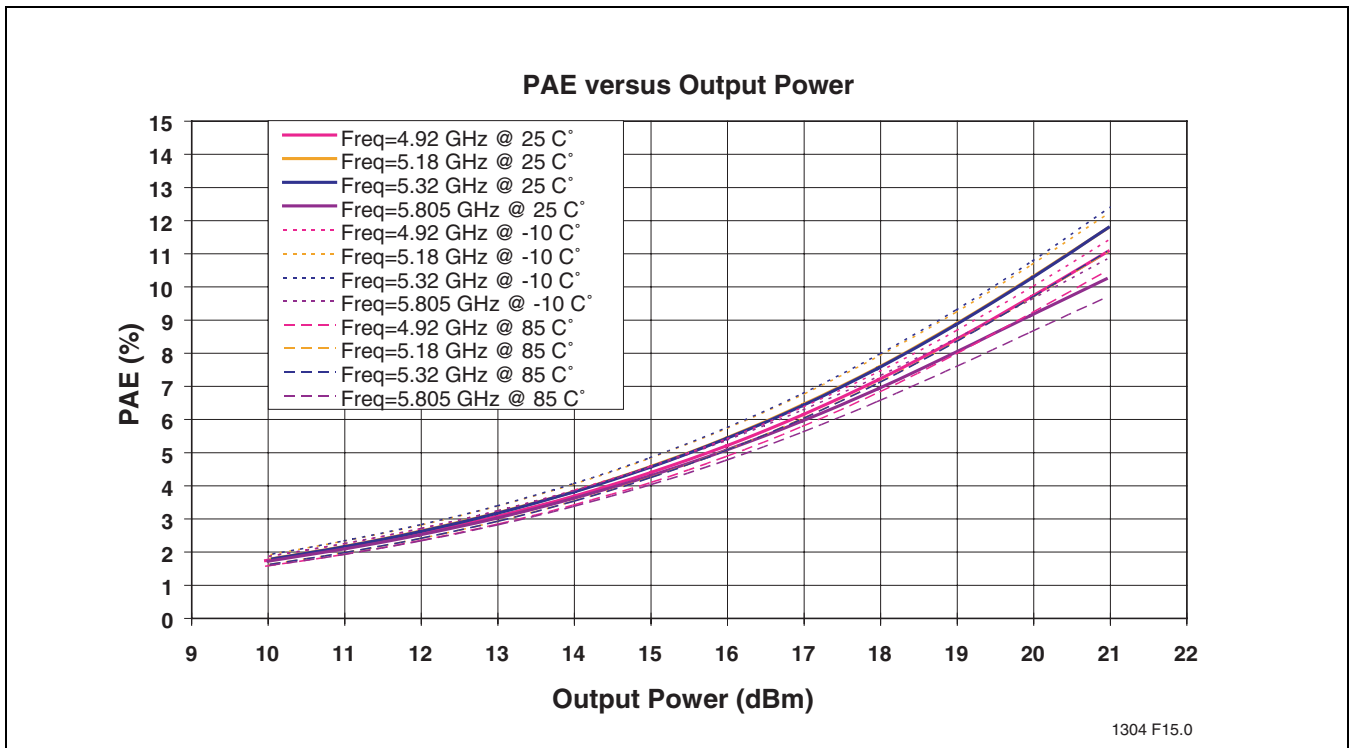

FIGURE 16: High Band PAE versus Output Power

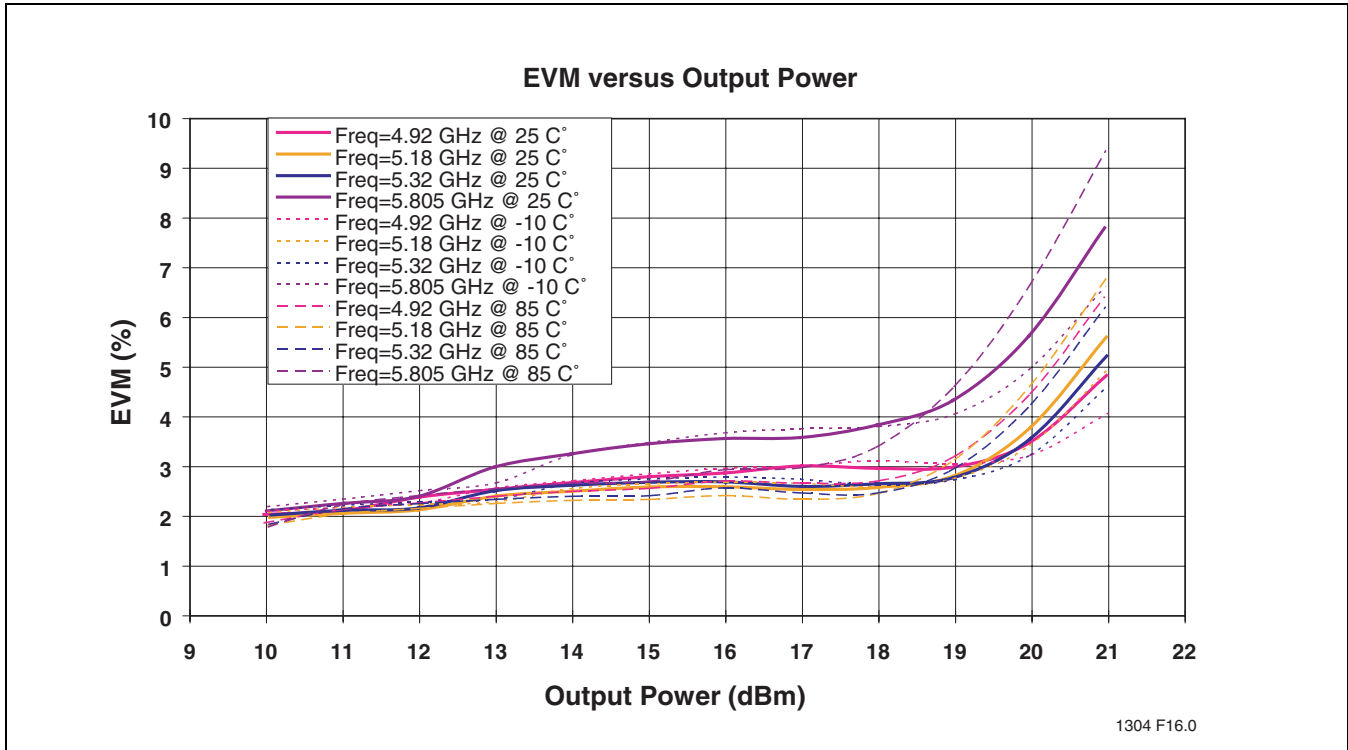

FIGURE 17: High Band EVM versus Output Power

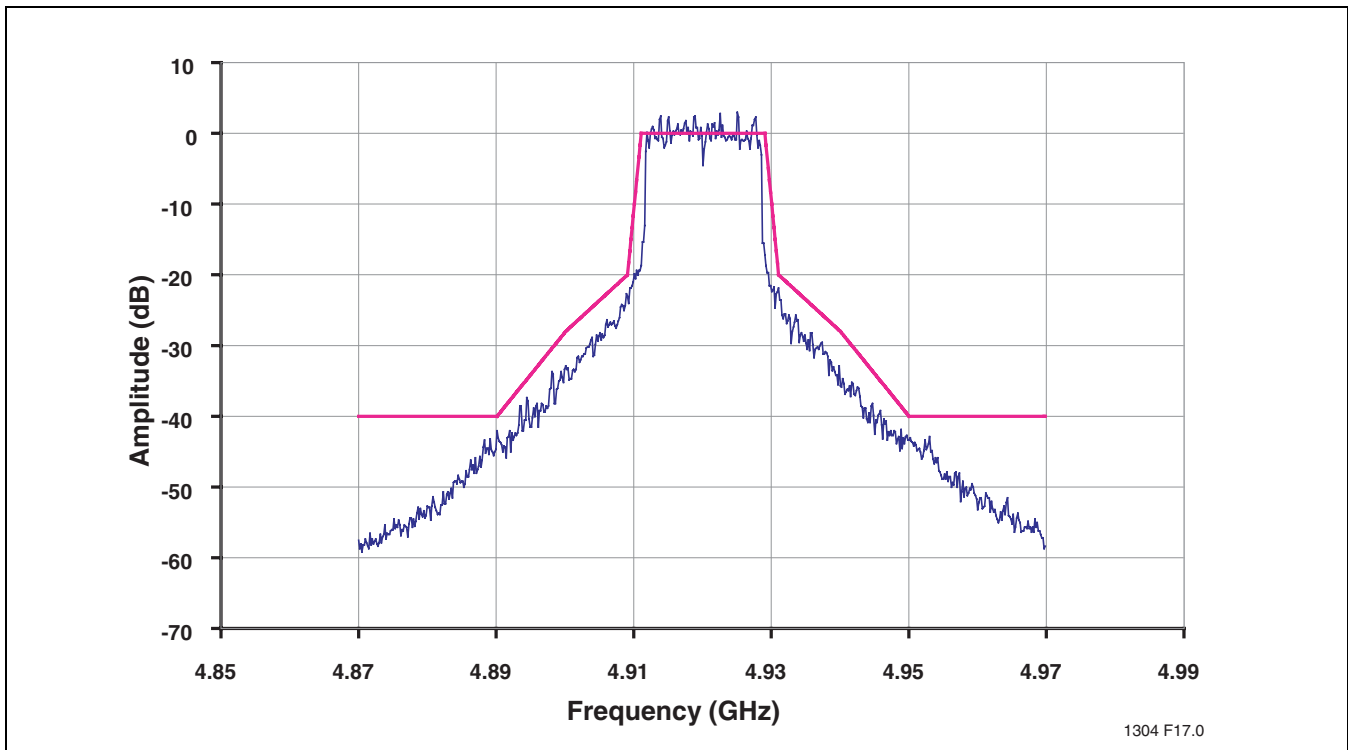

FIGURE 18: High Band 802.11a Spectrum Mask at 4.92 GHz at Output Power 22.5 dBm with DC Current at 410 mA



2.4-2.5 GHz / 4.9-5.8 GHz Dual-Band Power Amplifier SST13LP02

Data Sheet

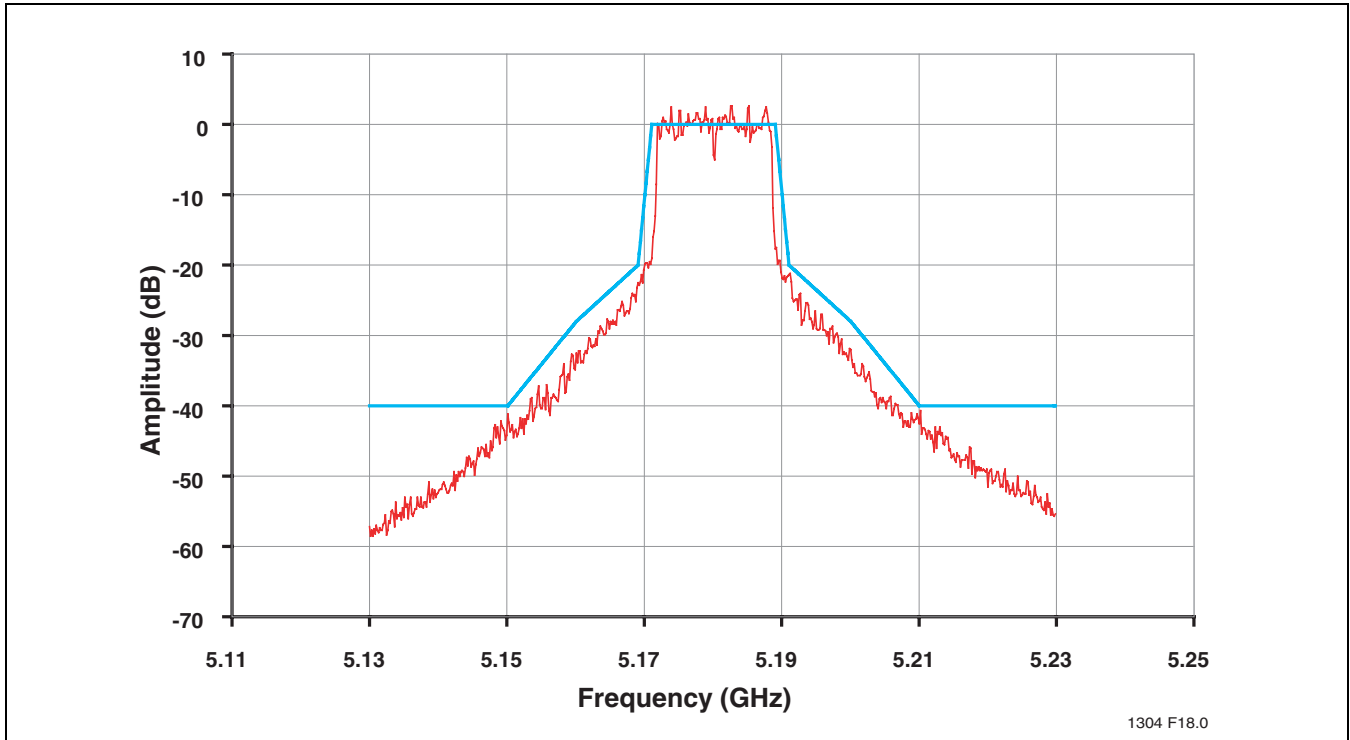

FIGURE 19: High Band 802.11a Spectrum Mask at 5.18 GHz at Output Power 22.5 dBm with DC Current at 380 mA

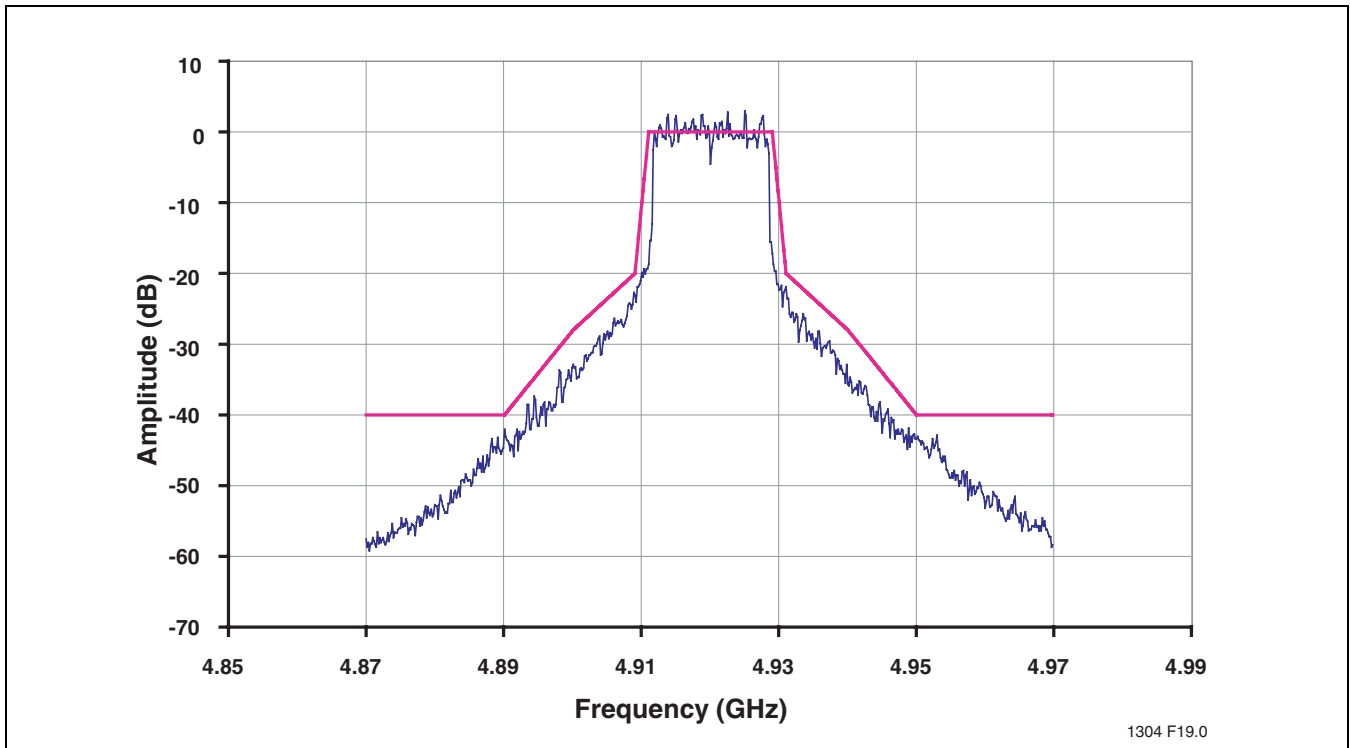

FIGURE 20: High Band 802.11a Spectrum Mask at 5.32 GHz at Output Power 22.5 dBm with DC Current at 380 mA

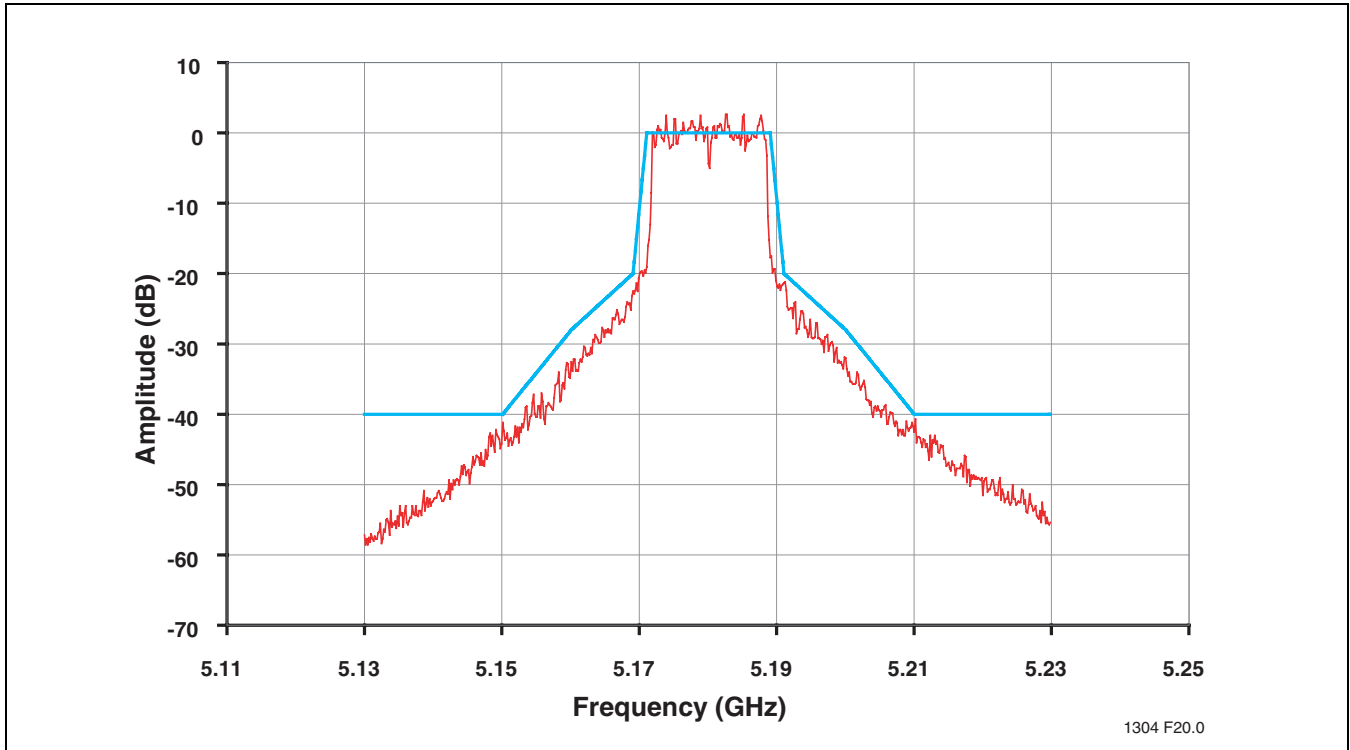

FIGURE 21: High Band 802.11a Spectrum Mask at 5.805 GHz at Output Power 22 dBm with DC Current at 390 mA



Data Sheet

High Band Power Detector characteristics

Test Conditions: VCC = 3.3V, 54 Mbps 802.11a OFSM Signal

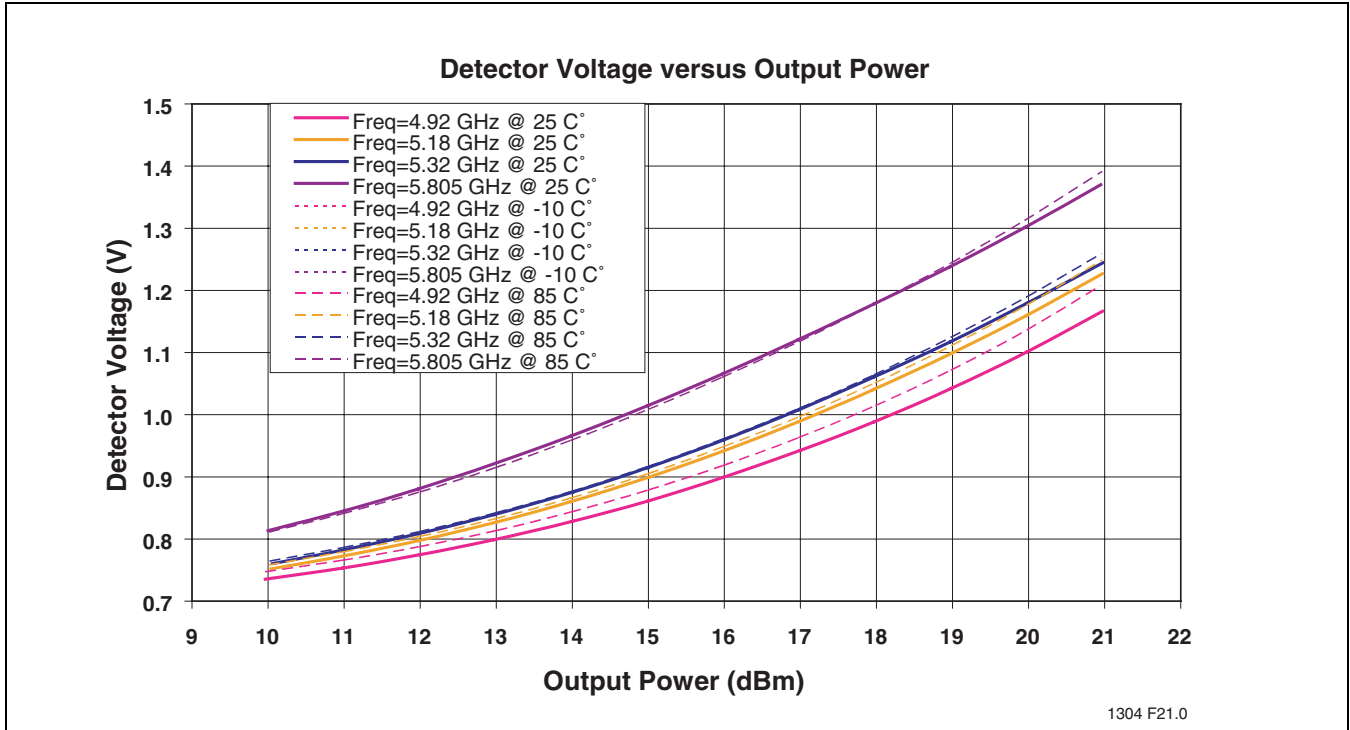

FIGURE 22: High Band Detector Voltage versus Output Power

2.4-2.5 GHz / 4.9-5.8 GHz Dual-Band Power Amplifier

SST13LP02



Data Sheet

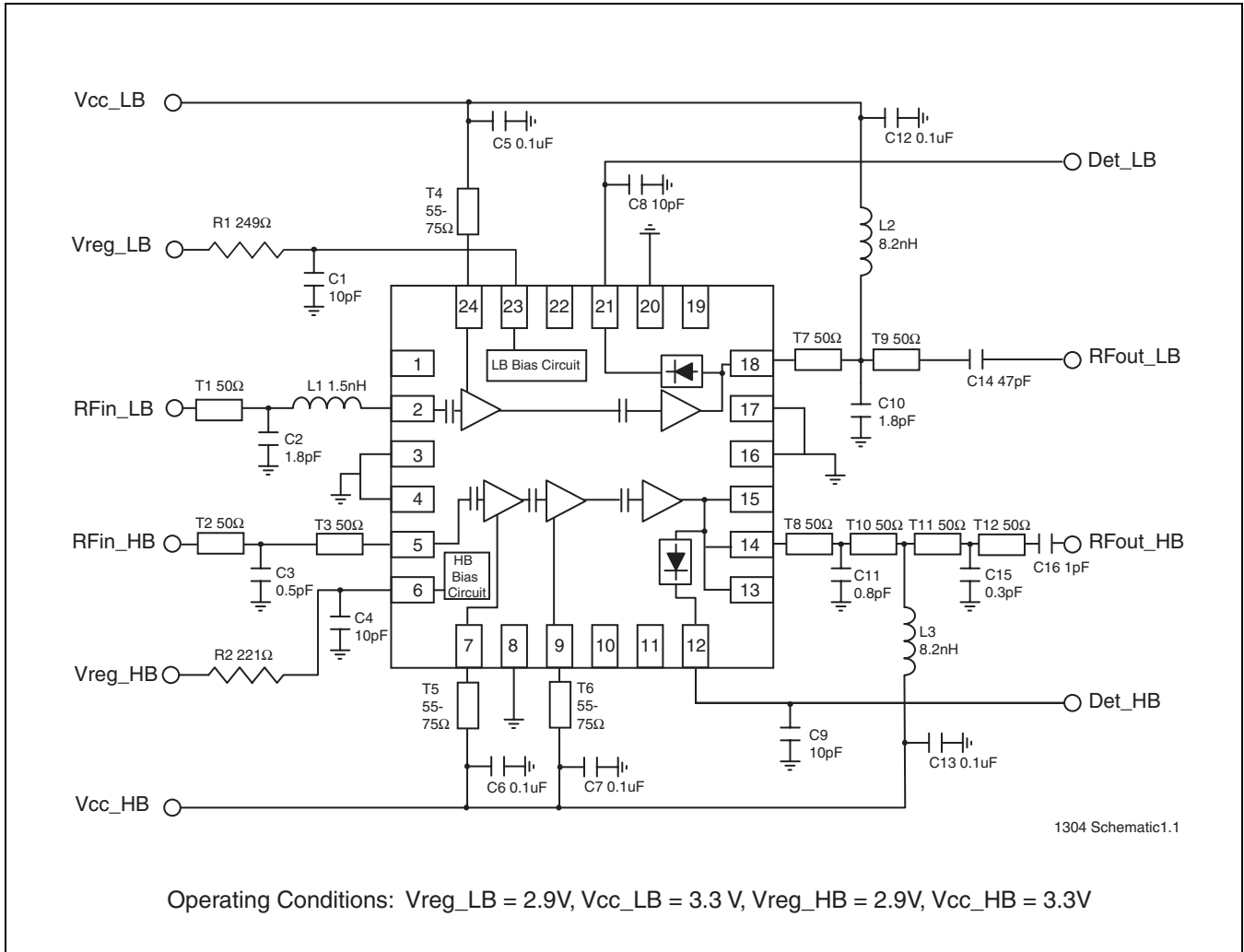

FIGURE 23: Typical Application Circuit



2.4-2.5 GHz / 4.9-5.8 GHz Dual-Band Power Amplifier SST13LP02

Data Sheet

TABLE 6: Part List

Symbol	Value	Note
C1	10pF	Larger value can be used if meeting on/off toggling speed requirement of low ban on system board
C2	1.8pF	LB input matching
C3	0.5 pF	HB input matching, no-pop if -6dB input return loss is acceptable
C4	10pF	Larger value can be used if meeting on/off toggling speed requirement for high band on system board
C5	0.1uF	LB bypassing
C6	0.1uF	HB bypassing
C7	0.1uF	HB bypassing
C8	10pF	LB power detector bypassing/video bandwidth control
C9	10pF	HB power detector bypassing/video bandwidth control
C10	1.8pF	LB band output matching, 1.5~2.0 pF determined by length/impedance of T7, high Q part preferred
C11	0.8pF	HB output matching, high Q cap preferred
C12	0.1uF	LB bypassing, position close to L2
C13	0.1uF	HB bypassing, position close to L3
C14	47pF	LB output DC blocking
C15	0.3pF	HB output matching, high Q cap preferred
C16	1pF	HB output matching / DC blocking
L1	1.5nH	LB input matching, can be replaced by an 240mil 50Ω microstrip
L2	8.2nH	LB output RF choke, coil type preferred
L3	8.2nH	HB output RF choke, coil type preferred
R1	249Ω	Needs adjusting for different Vreg_LB
R2	221Ω	Needs adjusting for different Vreg_HB or 4.9~5.9GHz simultaneous coverage with lower EVM
T1,T2,T9	50Ω	Length not critical
T3	50Ω	HB input matching, 50<length<70mil
T4	55~75Ω	Impedance not critical, recommended length=50mil (<130mil should be fine)
T5	55~75Ω	Impedance not critical, length=50mil ± 10mil
T6	55~75Ω	Impedance not critical, length=50mil ± 10mil
T7	50Ω	Recommend length =60mil with C10=1.8pF (40<length <120mil OK with C10=1.5~2.0pF)
T8	50Ω	Critical for HB output matching, length=30mil ± 5mil
T10	50Ω	Critical for HB output matching length=45mil ± 5mil
T11	50Ω	Critical for output matching, length=25mil ± 5mil
T12	50Ω	Length = 40mil±5mil

T6.1 1304



2.4-2.5 GHz / 4.9-5.8 GHz Dual-Band Power Amplifier SST13LP02

Data Sheet

packaging diagrams

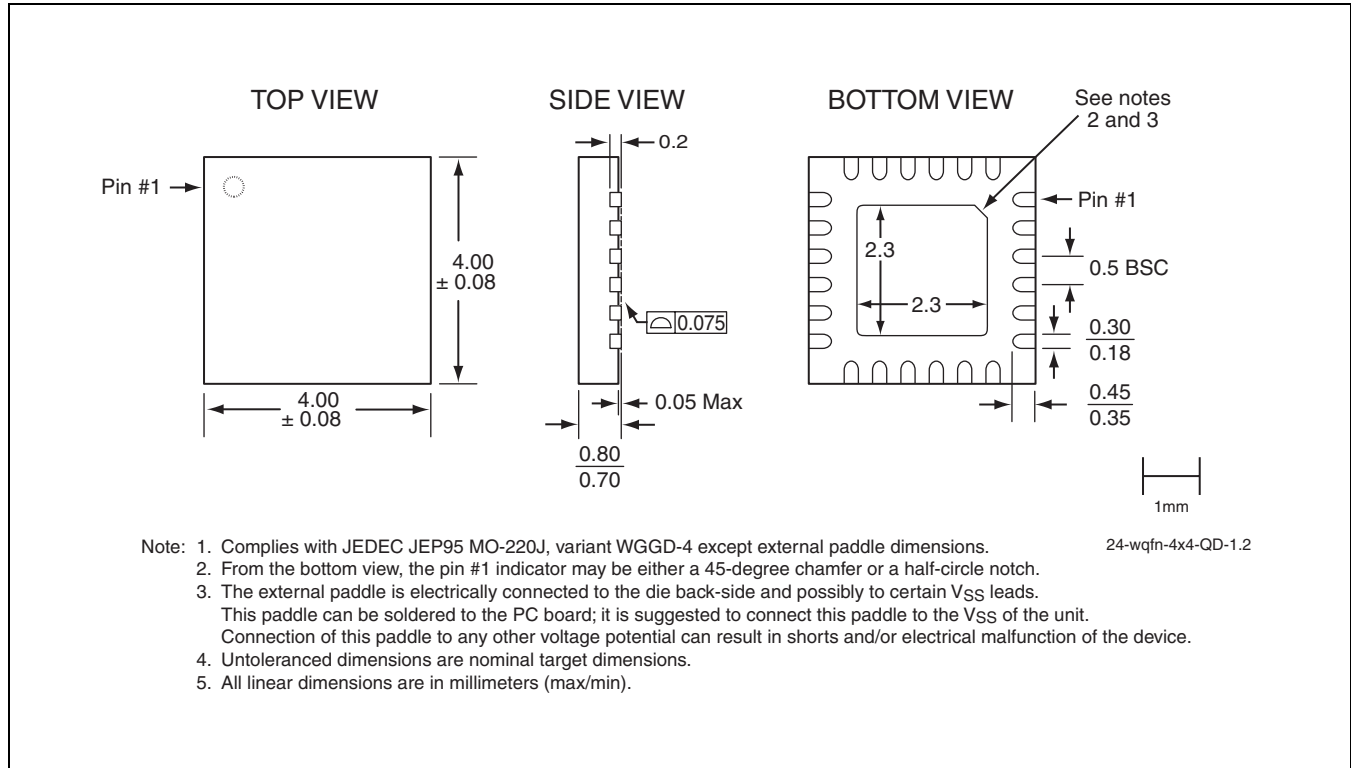

**FIGURE 24: 24-contact Very-very-thin-profile Quad Flat No-lead (WQFN)
SST Package Code: QD**

TABLE 7: Revision History

Revision	Description	Date
00	• 1304: Conversion from MRD SST13LP02	Nov 2005
01	• Updated information for pins 3, 4, 16, and 17 in Figures 1 and 2 and Table 1. • Updated Figure 23. • Revised AC Electrical Characteristics for Configuration tables 3 and 5.	Sep 2006
02	• Updated document status from Preliminary Specification to Data Sheet	Apr 2008
03	• Updated "Contact Information" on page 25.	Feb 2009



2.4-2.5 GHz / 4.9-5.8 GHz Dual-Band Power Amplifier SST13LP02

Data Sheet

Contact Information

Marketing

SST Communications Corp.
5340 Alla Road, Ste. 210
Los Angeles, CA 90066
Tel: 310-577-3600
Fax: 310-577-3605

Sales and Marketing Offices

NORTH AMERICA

Silicon Storage Technology, Inc.
1171 Sonora Court
Sunnyvale, CA 94086-5308
Tel: 408-735-9110
Fax: 408-735-9036

EUROPE

Silicon Storage Technology Ltd.
Mark House
9-11 Queens Road
Hersham, Surrey
KT12 5LU UK
Tel: 44 (0) 1932-238133
Fax: 44 (0) 1932-230567

JAPAN

SST Japan
NOF Tameike Bldg, 9F
1-1-14 Akasaka, Minato-ku
Tokyo, Japan 107-0052
Tel: 81-3-5575-5515
Fax: 81-3-5575-5516

ASIA PACIFIC NORTH

SST Macao
Room N, 6th Floor,
Macao Finance Center, No. 202A-246,
Rua de Pequim, Macau
Tel: 853-2870-6022
Fax: 853-2870-6023

ASIA PACIFIC SOUTH

SST Communications Co.
16F-6, No. 75, Sec.1, Sintai 5th Rd
Sijhih City, Taipei County 22101
Taiwan, R.O.C.
Tel: 886-2-8698-1198
Fax: 886-2-8698-1190

KOREA

SST Korea
6F, Heungkuk Life Insurance Bldg 6-7
Sunae-Dong, Bundang-Gu, Sungnam-Si
Kyungki-Do, Korea, 463-020
Tel: 82-31-715-9138
Fax: 82-31-715-9137

Silicon Storage Technology, Inc. • 1171 Sonora Court • Sunnyvale, CA 94086 • Telephone 408-735-9110 • Fax 408-735-9036
www.SuperFlash.com or www.sst.com
