

CMOS Programmable Ionization Smoke Detector ASIC with Interconnect, Timer Mode and Alarm Memory

Features

- 6 – 12V Operation
- Low Quiescent Current Consumption
- Programmable Standby Sensitivity
- Programmable HUSH Sensitivity
- Programmable Hysteresis
- Programmable Chamber Voltage for Push-to-Test (PTT) and Chamber Test
- Programmable ± 150 mV Low Battery Set Point
- Internal Ionization Chamber Test
- Internal Low Battery Test
- Internal Power-On Reset and Power-up Low Battery Test
- Alarm Memory
- Auto Alarm Locate
- Horn Synchronization
- IO Filter and Charge Dump
- Smart Interconnect
- Interconnect up to 40 Detectors
- $\pm 5\%$ All Internal Oscillator
- 9 Minute or 80 Second Timer for Sensitivity Control
- Temporal or Continuous Horn Pattern
- Guard Outputs for Ion Detector Input
- ± 0.75 pA Detect Input Current
- 10-year End-of-Life Indication

Description

The RE46C180 is a next generation low power, CMOS ionization-type, smoke detector IC. With minimal external components, this circuit will provide all the required features for an ionization-type smoke detector.

An on-chip oscillator strobes power to the smoke detection circuitry for 5 ms every 10 seconds to keep the standby current to a minimum.

A check for a Low Battery condition is performed every 80s and an ionization chamber test is performed once every 320s when in Standby. The temporal horn pattern complies with the National Fire Protection Association NFPA 72[®] National Fire Alarm and Signaling Code[®] for emergency evacuation signals.

An interconnect pin allows multiple detectors to be connected, such that when one unit alarms, all units will sound. A charge dump feature quickly discharges the interconnect line when exiting a Local Alarm condition. The interconnect input is also digitally filtered.

An internal 9 minute or 80s timer can be used for a Reduced Sensitivity mode.

An alarm memory feature allows the user to determine whether the unit has previously entered a Local Alarm condition.

Utilizing low-power CMOS technology, the RE46C180 is designed for use in smoke detectors that comply with the Standard for Single and Multiple Station Smoke Alarms, UL217 and the Standard for Smoke Detectors for Fire Alarm Systems, UL268.

Package Types

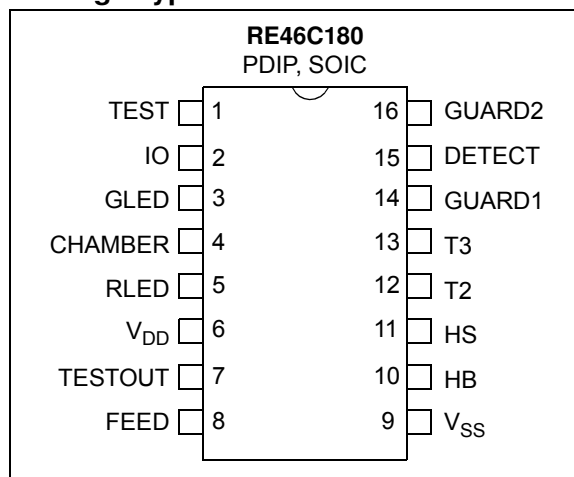

RE46C180

Functional Block Diagram

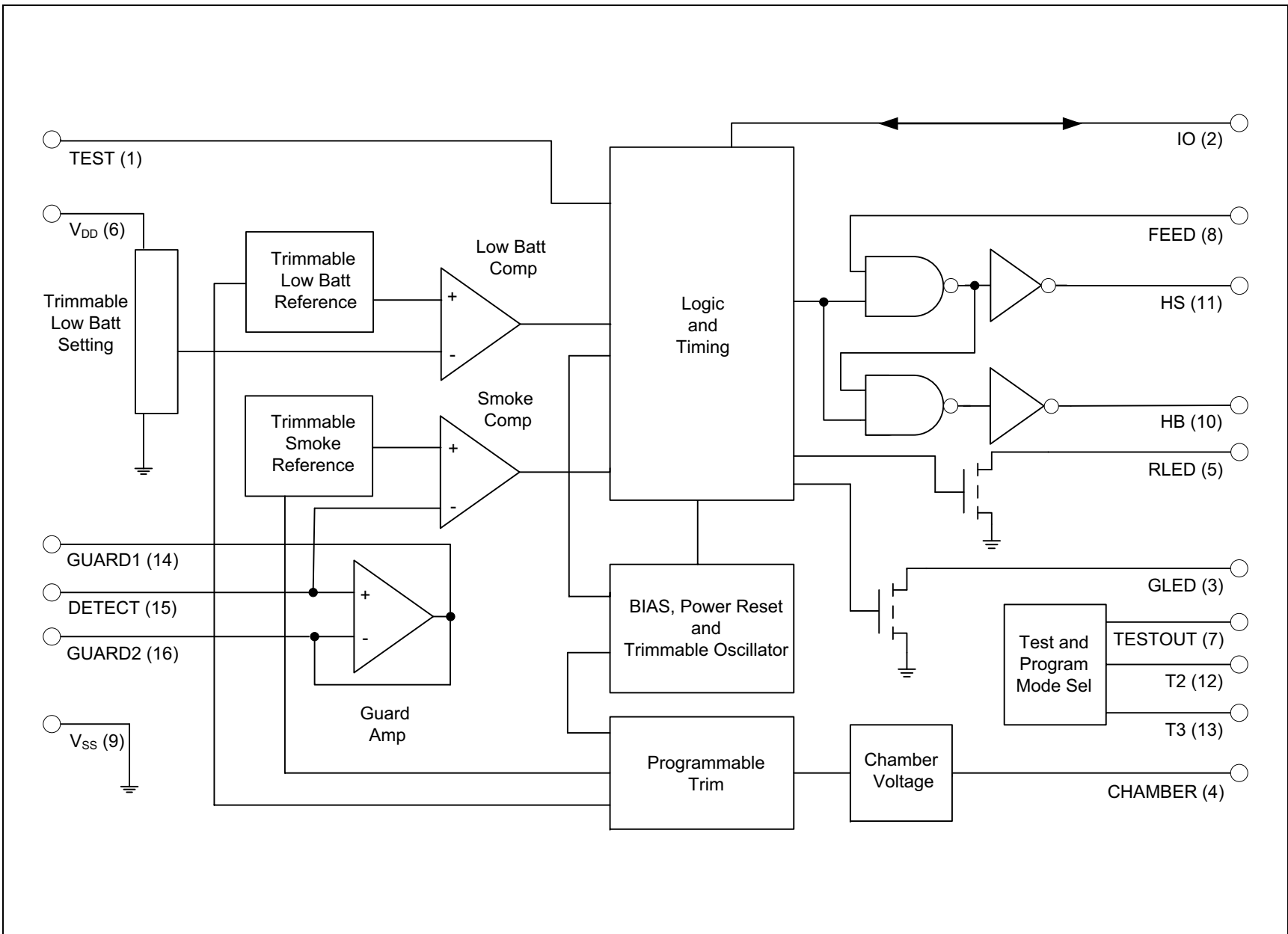

Typical Application

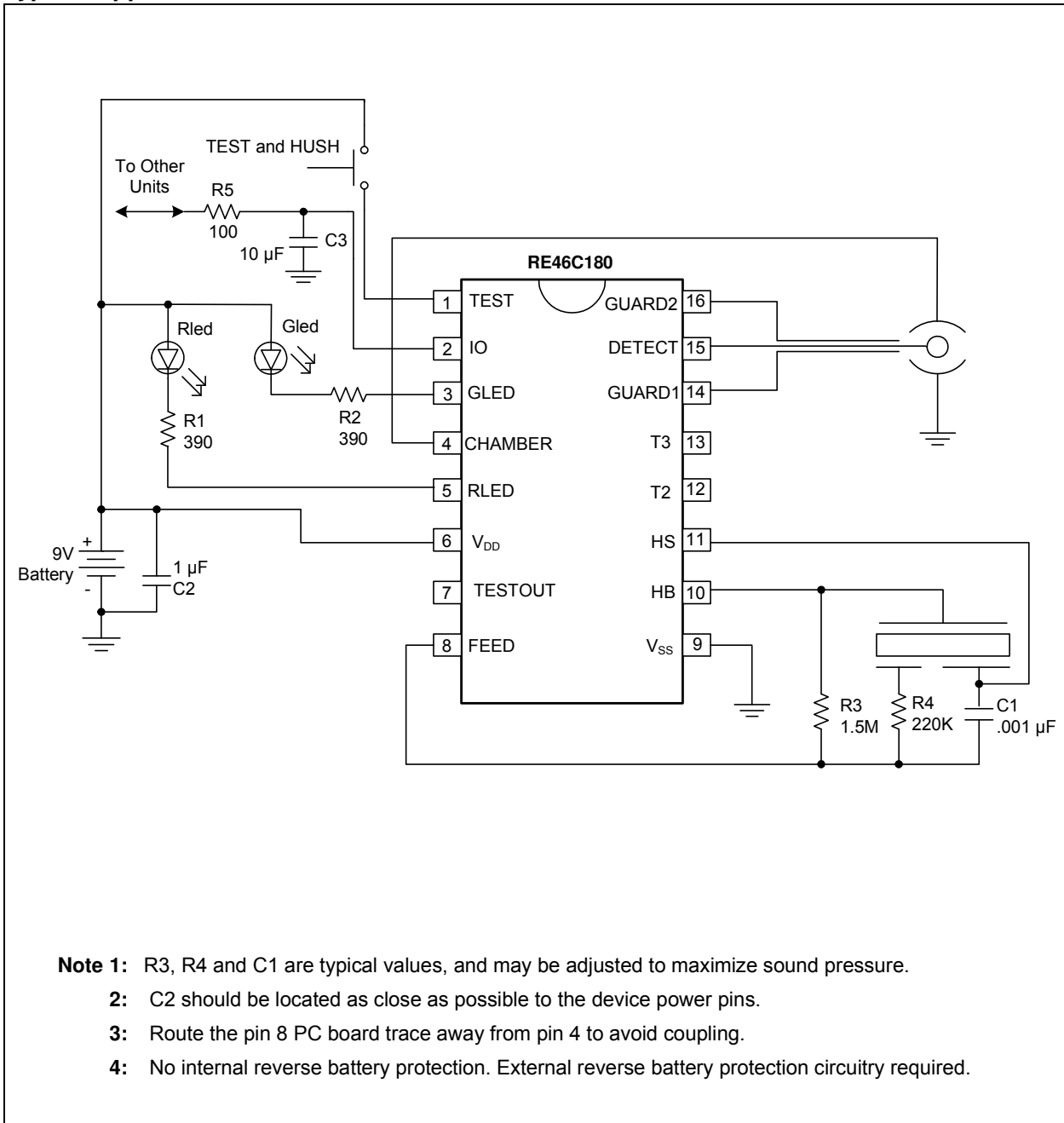

RE46C180

1.0 ELECTRICAL CHARACTERISTICS

1.1 Absolute Maximum Ratings†

V _{DD}	12.5V
Input Voltage Range Except FEED, IO.....	V _{IN} = -3V to V _{DD} +3V
FEED Input Voltage Range.....	V _{INFD} = -10 to +22V
IO Input Voltage Range.....	V _{IO1} = -3 to 15V
Input Current except FEED.....	I _{IN} = 10 mA
Operating Temperature.....	T _A = -10 to +60°C
Storage Temperature.....	T _{STG} = -55 to +125°C
Maximum Junction Temperature.....	T _J = +150°

† **Notice:** Stresses above those listed under “Maximum ratings” may cause permanent damage to the device. This is a stress rating only and functional operation of the device at these or any other conditions above those indicated in the operation listings of this specification is not implied. Exposure to maximum rating conditions for extended periods may affect device reliability.

DC ELECTRICAL CHARACTERISTICS

DC Electrical Characteristics: Unless otherwise indicated, all parameters apply at T_A = -10°C to +60°C, V_{DD} = 9V, V_{SS} = 0V (Note 1)

Parameter	Symbol	Test Pin	Min	Typ	Max	Units	Conditions
Supply Voltage	V _{DD}	6	6	—	12	V	Operating
Supply Current	I _{DD1}	6	—	3.8	5.3	µA	Operating, RLED off, GLED off
	I _{DD2}	6	—	—	6	µA	Operating, V _{DD} = 12V, RLED off, GLED off
	I _{DD3}	6	—	9.6	13.9	µA	Operating, RLED off, GLED off, Smoke check
	I _{DD4}	6	—	21.4	30	µA	Operating, RLED off, GLED off, Low Battery check
Input Voltage High	V _{IH1}	8	6	—	—	V	
	V _{IH2}	2	3	—	—	V	No Local Alarm, IO as an input
	V _{IH3}	1	5.6	—	—	V	
	V _{IH4}	12	5.6	—	—	V	
Input Voltage Low	V _{IL1}	8	—	—	2.8	V	
	V _{IL2}	2	—	—	1	V	No Local Alarm, IO as an input
	V _{IL3}	1	—	—	3.4	V	
	V _{IL4}	12	—	—	3.4	V	
Input Leakage Low	I _{LDET1}	15	—	—	-0.75	pA	V _{DD} = 9V, DETECT = V _{SS} , 0-40% RH, T _A = +25°C
	I _{LDET2}	15	—	—	-1.5	pA	V _{DD} = 9V, DETECT = V _{SS} , 85% RH, T _A = +25°C (Note 2)
	I _{LFD1}	8	—	—	-50	µA	FEED = -10V
	I _{LFD2}	8	—	—	-100	nA	FEED = V _{SS}

Note 1: Production tested at room temperature with temperature guard banded limits.

2: Sample test only.

3: Not 100% production tested.

4: Same limit range at each programmable step, see [Table 4-1](#).

DC ELECTRICAL CHARACTERISTICS (CONTINUED)

DC Electrical Characteristics: Unless otherwise indicated, all parameters apply at $T_A = -10^{\circ}\text{C}$ to $+60^{\circ}\text{C}$, $V_{DD} = 9\text{V}$, $V_{SS} = 0\text{V}$ (Note 1)

Parameter	Symbol	Test Pin	Min	Typ	Max	Units	Conditions
Input Leakage High	$I_{H_{DET1}}$	15	—	—	0.75	μA	$V_{DD} = 9\text{V}$, $\text{DETECT} = V_{DD}$, 0–40% RH, $T_A = +25^{\circ}\text{C}$
	$I_{H_{DET2}}$	15	—	—	1.5	μA	$V_{DD} = 9\text{V}$, $\text{DETECT} = V_{DD}$, 85% RH, $T_A = +25^{\circ}\text{C}$ (Note 2)
	$I_{H_{FD1}}$	8	—	—	50	μA	$\text{FEED} = 22\text{V}$
	$I_{H_{FD2}}$	8	—	—	100	nA	$\text{FEED} = V_{DD}$
	I_{IOL2}	2	—	—	150	μA	No Alarm, $V_{IO} = 15\text{V}$
Output Off Leakage High	I_{IOHZ}	3, 5	—	—	1	μA	Outputs Off, $V_{RLED} = 9\text{V}$, $V_{GLED} = 9\text{V}$
Input Pull Down Current	I_{PD1}	1	20	50	80	μA	$\text{TEST} = 9\text{V}$
	I_{PD2}	12	0.4	0.8	1.3	mA	$T2 = 9\text{V}$
Output High Voltage	V_{OH1}	10,11	6.3	—	—	V	$I_{OH} = -16\text{mA}$, $V_{DD} = 7.2\text{V}$
Output Low Voltage	V_{OL1}	10,11	—	—	0.9	V	$I_{OL} = 16\text{mA}$, $V_{DD} = 7.2\text{V}$
	V_{OL3}	3, 5	—	—	1	V	$I_{OL} = 10\text{mA}$, $V_{DD} = 7.2\text{V}$
Output Current	I_{IOL1}	2	25	—	60	μA	No Alarm, $V_{IO} = V_{DD} - 2\text{V}$
	I_{IOH1}	2	-4	—	-16	mA	Alarm, $V_{IO} = 4\text{V}$ or $V_{IO} = 0\text{V}$
	I_{IODMP}	2	5	—	—	mA	At conclusion of Local Alarm or PTT, $V_{IO} = 1\text{V}$
Low Battery Voltage	V_{LB}	6	6.75	6.9	7.05	V	$\text{LBTR}[2:1] = 1\ 0$
			7.05	7.2	7.35	V	$\text{LBTR}[2:1] = 1\ 1$
			7.35	7.5	7.65	V	$\text{LBTR}[2:1] = 0\ 0$
			7.65	7.8	7.95	V	$\text{LBTR}[2:1] = 0\ 1$
Offset Voltage	V_{GOS1}	14,15	-50	—	50	mV	Guard amplifier
	V_{GOS2}	15,16	-50	—	50	mV	Guard amplifier
	V_{GOS3}	15	-50	—	50	mV	Smoke comparator
Common Mode Voltage	V_{CM1}	14,15	2	—	$V_{DD} - .5$	V	Guard amplifier (Note 3)
	V_{CM2}	15	0.5	—	$V_{DD} - 2$	V	Smoke comparator (Note 3)
Output Impedance	Z_{OUT}	14,16	—	10	—	$\text{k}\Omega$	Guard amplifier outputs (Note 3)
Chamber Voltage in PTT/Chamber Test	$V_{CHAMBER}$	4	4.49	4.5	4.51	V	User programmable (2.1V to 6.75V) (Note 4)
Hysteresis	V_{HYS}	13	140	150	160	mV	No Alarm to Alarm condition, user programmable (50 to 225 mV) (Note 4)

- Note 1:** Production tested at room temperature with temperature guard banded limits.
Note 2: Sample test only.
Note 3: Not 100% production tested.
Note 4: Same limit range at each programmable step, see Table 4-1.

RE46C180

AC ELECTRICAL CHARACTERISTICS

AC Electrical Characteristics: Unless otherwise indicated, all parameters apply at $T_A = -10^{\circ}\text{C}$ to $+60^{\circ}\text{C}$, $V_{DD} = 9\text{V}$, $V_{SS} = 0\text{V}$.

Parameter	Symbol	Test Pin	Min	Typ	Max	Units	Conditions
Time Base							
Internal Oscillator Period	T_{POSC}	7	593	625	657	μs	Test mode (Note 1)
Internal Clock Period	T_{PCLK}		9.5	10	10.5	ms	Operating
RLED Indicator							
On Time	T_{ON1}	5	9.5	10	10.5	ms	Operating
Period	T_{PLED1}	5	304	320	336	s	Standby
	T_{PLED2}	5	0.95	1	1.05	s	Local alarm
	T_{PLED3}	5	9.5	10	10.5	s	HUSH mode, No Local Alarm
GLED Indicator							
Period	T_{PLED4}	3	38	40	42	s	Alarm Memory Indication GLED period, No Alarm, no PTT
	T_{PLED5}	3	237	250	263	ms	Alarm Memory Indication GLED period upon PTT, $\text{AMLEDEn} = 1$
Off Time	T_{OFLED1}	3	0.95	1	1.05	s	Alarm Memory Indication GLED off time between pulses
	T_{OFLED2}	3	36	38	40	s	Alarm Memory Indication GLED off time between pulse trains (3x)
Alarm Memory Indication Timeout Period	T_{AMTO}	3	22.8	24	25.2	Hour	$\text{AMTO}[2:1] = 0\ 0$
			45.6	48	50.4	Hour	$\text{AMTO}[2:1] = 0\ 1$
			0	0	0	Hour	$\text{AMTO}[2:1] = 1\ 0$, No Alarm Memory Indication
			—	—	—	—	$\text{AMTO}[2:1] = 1\ 1$, Alarm Memory Indication never times out, as long as Alarm Memory Latch is set
Smoke Check							
Smoke Check Time	T_{SCT}	—	4.7	5	5.3	ms	Operating
Smoke Check Period	T_{PER0}	—	9.5	10	10.5	s	Standby, No Alarm
	T_{PER1}	—	0.95	1	1.05	s	Standby, after one valid smoke sample and before entering Local Alarm, no PTT
	T_{PER2}	—	237	250	263	ms	Standby, upon start of PTT and before entering Local Alarm
	T_{PER3}	—	0.95	1	1.05	s	Local Alarm (after three con- secutive valid smoke samples) or Remote Alarm
Chamber Test Period	T_{PCT1}	—	304	320	336	s	Operating

Note 1: T_{POSC} is 100% production tested. All other timing is verified by functional testing.

Note 2: See timing diagram for CO alarm horn pattern.

Note 3: See timing diagram for smoke alarm temporal and non-temporal horn pattern.

Note 4: See timing diagram for horn synchronization and Auto Alarm Locate (AAL).

AC ELECTRICAL CHARACTERISTICS (CONTINUED)

AC Electrical Characteristics: Unless otherwise indicated, all parameters apply at $T_A = -10^{\circ}\text{C}$ to $+60^{\circ}\text{C}$, $V_{DD} = 9\text{V}$, $V_{SS} = 0\text{V}$.							
Parameter	Symbol	Test Pin	Min	Typ	Max	Units	Conditions
Low Battery							
Low Battery Check Period	T_{PLB1}	—	76	80	84	s	Standby, No Alarm, No Low Battery
	T_{PLB2}	—	304	320	336	s	Standby, No Alarm, Low Battery
Horn Operation							
Horn Delay	T_{HDLY1}	10, 11	475	500	525	ms	From Local Alarm to Horn Active, temporal horn pattern
	T_{HDLY2}	10, 11	380	400	420	ms	From Local Alarm to Horn Active, continuous horn pattern
Horn Period	T_{HPER1}	10, 11	38	40	42	s	Low Battery, No Alarm
	T_{HPER2}	10, 11	38	40	42	s	Chamber Failure, No Alarm
	T_{HPER3}	10, 11	237	250	263	ms	Alarm Memory Indication upon PTT, AMHCEn=1
	T_{HPER4}	10, 11	5.5	5.8	6.1	s	CO Alarm horn period (Note 2)
Horn On Time	T_{HON1}	10, 11	9.5	10	10.5	ms	1. Low Battery, No Alarm 2. Chamber Failure 3. Alarm Memory Indication upon PTT, AMHCEn = 1
	T_{HON2}	10, 11	475	500	525	ms	Smoke Alarm, temporal horn pattern (Note 3)
	T_{HON3}	10, 11	332	350	368	ms	Smoke Alarm, continuous horn pattern (Note 3)
	T_{HON4}	10, 11	95	100	105	ms	CO Alarm, COEn = 1
Horn Off Time	T_{HOF1}	10, 11	475	500	525	ms	Smoke Alarm, temporal horn pattern (Note 3)
	T_{HOF2}	10, 11	1.43	1.5	1.58	s	Smoke Alarm, temporal horn pattern (Note 3)
	T_{HOF3}	10, 11	143	150	158	ms	Smoke Alarm, continuous horn pattern (Note 3)
	T_{HOF4}	10, 11	37	39	41	s	Chamber Fail horn off time between pulse trains (3x)
	T_{HOF5}	10, 11	465	490	515	ms	Chamber Fail horn off time between pulses
	T_{HOF6}	10, 11	95	100	105	ms	CO Alarm horn off time between pulses, COEn = 1 (Note 2)
	T_{HOF7}	10, 11	4.8	5.1	5.4	s	CO alarm horn off time between pulse trains, COEn = 1 (Note 2)

Note 1: T_{POSC} is 100% production tested. All other timing is verified by functional testing.

2: See timing diagram for CO alarm horn pattern.

3: See timing diagram for smoke alarm temporal and non-temporal horn pattern.

4: See timing diagram for horn synchronization and Auto Alarm Locate (AAL).

RE46C180

AC ELECTRICAL CHARACTERISTICS (CONTINUED)

AC Electrical Characteristics: Unless otherwise indicated, all parameters apply at $T_A = -10^{\circ}\text{C}$ to $+60^{\circ}\text{C}$, $V_{DD} = 9\text{V}$, $V_{SS} = 0\text{V}$.							
Parameter	Symbol	Test Pin	Min	Typ	Max	Units	Conditions
Interconnect							
IO Active Delay	T_{IODLY1}	2	3.5	3.7	3.9	s	From start of Local Alarm to IO Active. SyncEn = 1
		2	3.1	3.3	3.5	s	From start of Local Alarm to IO Active. SyncEn = 0
Remote Smoke Alarm Delay	T_{IODLY2}	2	769	810	851	ms	No Local Alarm, from IO Active to Alarm, temporal horn pattern
	T_{IODLY3}	2	299	315	331	ms	No Local Alarm, from IO Active to alarm, continuous horn pattern
IO Filter for Remote Smoke Alarm	T_{IOFILT}	2	—	—	291	ms	IO pulse-width to be filtered IO as input, no Local Alarm
IO Pulse On Time for CO Alarm	T_{IOPW1}	2	37	—	290	ms	No Local Alarm, 2 valid pulses required for CO
IO Pulse Off Time for CO Alarm	T_{IOTO1}	2	—	—	5.4	s	IO = Low
IO Dump	T_{IODMP1}	2	475	500	525	ms	At conclusion of Local Alarm or PTT
Horn Synchronization							
IO Pulse Period	T_{PIO1}	2	3.8	4	4.2	s	Local Alarm, temporal horn pattern, SyncEn = 1 (Note 4)
IO Pulse On Time	T_{ONIO}	2	3.41	3.59	3.77	s	Local Alarm, temporal horn pattern, SyncEn = 1 (Note 4)
Horn Sync IO Dump	T_{IODMP2}	2	95	100	105	ms	Local Alarm, SyncEn = 1 (Note 4)
Horn Sync IO Dump Delay	T_{IODLY4}	2	285	300	315	ms	Local Alarm, SyncEn = 1 (Note 4)
Auto Alarm Locate (AAL)							
IO Cycle Period	T_{PIO2}	2	15.2	16	16.8	s	Local Alarm, temporal horn pattern, SyncEn = 1, NoAAL = 0 (Note 4)
IO Cycle Off Time	T_{OFIO}	2	4.19	4.41	4.63	s	Local Alarm, temporal horn pattern, SyncEn = 1, No AAL = 0, IO off time between IO pulse trains (3x) (Note 4)
HUSH Timer Operation							
HUSH Timer Period	T_{TPER}	—	8.5	9	9.5	min	No Alarm, ShrtTO = 0
		—	76	80	84	s	No Alarm, ShrtTO = 1
EOL							
End-of-Life Age Sample	T_{EOL}	—	346	364	382	Hours	Standby, EOLEn = 1

Note 1: T_{POSC} is 100% production tested. All other timing is verified by functional testing.

Note 2: See timing diagram for CO alarm horn pattern.

Note 3: See timing diagram for smoke alarm temporal and non-temporal horn pattern.

Note 4: See timing diagram for horn synchronization and Auto Alarm Locate (AAL).

TEMPERATURE CHARACTERISTICS

Electrical Specifications: Unless otherwise indicated, $V_{DD} = 9V$, $V_{SS} = 0V$						
Parameters	Sym	Min	Typ	Max	Units	Conditions
Temperature Ranges						
Operating Temperature Range	T_A	-10	—	+60	°C	
Storage Temperature Range	T_{STG}	-55	—	+125	°C	
Thermal Package Resistances						
Thermal Resistance, 16L-PDIP	θ_{JA}	—	70	—	°C/W	
Thermal Resistance, 16L-SOIC (150 mil.)	θ_{JA}	—	86.1	—	°C/W	

RE46C180

2.0 PIN DESCRIPTIONS

The descriptions of the pins are listed in [Table 2-1](#).

TABLE 2-1: PIN FUNCTION TABLE

RE46C180 PDIP, SOIC	Symbol	Function
1	TEST	This input is used to invoke Push-to-Test, Timer mode and Alarm Memory Indication. This input has an internal pull-down.
2	IO	This bidirectional pin provides the capability to interconnect many detectors in a single system. This pin has an internal pull-down device and a charge dump device.
3	GLLED	Open drain NMOS output, used to drive a visible LED to provide visual indication of an Alarm Memory condition.
4	CHAMBER	Connect to the ionization smoke chamber. This pin provides power to the chamber
5	RLED	Open drain NMOS output, used to drive a visible LED. This pin provides the load current for the Low Battery test, and is a visual indicator for alarm and HUSH mode.
6	V _{DD}	Connect to the positive supply voltage
7	TESTOUT	This output is an indicator of the internal IO dump signal. This pin is also used for Test modes.
8	FEED	Usually connected to the feedback electrode through a current limiting resistor. If not used, this pin must be connected to V _{DD} or V _{SS} .
9	V _{SS}	Connect to the negative supply voltage.
10	HB	This pin is connected to the metal electrode of a piezoelectric transducer.
11	HS	This pin is a complementary output to HB, connected to the ceramic electrode of the piezoelectric transducer.
12	T2	Test input to invoke Test modes. This pin has an internal pull-down.
13	T3	Test output for Test modes.
14	GUARD1	Output of the guard amplifier. This allows for measurement of the DETECT input without loading the ionization chamber.
15	DETECT	Connect to the CEV of the ionization smoke chamber.
16	GUARD2	Output of the guard amplifier. This allows for measurement of the DETECT input without loading the ionization chamber.

3.0 DEVICE DESCRIPTIONS

3.1 Standby Internal Timing

The internal oscillator is manufactured to $\pm 5\%$ tolerance. The oscillator period, T_{OSC} , is $625 \mu s$. The internal clock period, T_{PCLK} , of 10 ms is derived from the internal oscillator period.

In Standby, once every 10s, the smoke detection circuitry is powered on for 5 ms. At the conclusion of the 5 ms, the status of the smoke comparator is latched. If a Smoke condition is present, the period to the next detection decreases and additional checks are made.

In Standby, once every 80s, the Low Battery detection circuitry is powered on for 10 ms. At the conclusion of the 10 ms, the status of the Low Battery comparator is latched. RLED is enabled for 10 ms every 320s to provide a battery load in the loaded battery test.

In Standby, once every 320s, the chamber test circuitry is powered on for 5 ms. At the conclusion of the 5 ms, the status of the chamber test is latched. See **Section 3.3 “Supervisory Tests”** for details.

3.2 Smoke Detection Circuitry

The collection electrode voltage (CEV) of the ionization chamber is compared to the stored reference voltage at the conclusion of the 5 ms smoke sample period. After the first Smoke condition is detected, the smoke detection rate increases to once every 1s. Three consecutive smoke detections will cause the device to go into Local Alarm, and the horn circuit and IO will be active. RLED will turn on for 10 ms at 1 Hz rate.

In Local Alarm, the smoke reference voltage (smoke sensitivity) is internally increased to provide alarm hysteresis.

There are three separate smoke sensitivity settings (all user programmable):

- Standby sensitivity
- Local alarm (hysteresis) sensitivity
- HUSH sensitivity

During PTT, the standby smoke sensitivity is used in smoke detection; but the CHAMBER voltage is user programmable.

The guard amplifier and outputs are always active, and will be within 50 mV of the DETECT input to reduce surface leakage. The guard outputs also allow for measurement of the DETECT input without loading the ionization chamber.

3.3 Supervisory Tests

Once every 80s, the status of the battery voltage is checked by comparing a fraction of the V_{DD} voltage to an internal reference. In each period of 320s, the battery is checked four times. Of these four battery checks, three are unloaded and one is loaded with RLED enabled, which provides a battery load. Low battery status is latched at the end of the 10 ms RLED pulse.

If the Low Battery test fails, the horn will chirp for 10 ms every 40s, and will continue to chirp until the next loaded Low Battery check is passed. The unloaded Low Battery checks are skipped in Low Battery condition.

As a user programmable option, a Low Battery Hush mode can be selected. If a Low Battery condition exists, upon release of PTT, the unit will enter the Low Battery Hush mode, and the 10 ms horn chirp will be silenced for 8 hours. At the conclusion of the 8 hours the audible indication will resume, if the Low Battery condition still exists

In addition, every 320s, a background chamber test is performed by internally lowering the CHAMBER voltage to a pre-determined level (user programmable) for 3.7s. This will emulate a Smoke condition. At the end of this 3.7s period, the smoke detection circuitry is powered on for 5 ms, and the Smoke condition is detected.

If two consecutive chamber tests failed to detect a simulated Smoke condition, the chamber fail latch is set and the failure warning is generated. The horn will chirp three times every 40s. Each chirp is 10 ms long and three chirps are spaced at a 0.5s interval. The chamber fail warning chirp is separated from the Low Battery warning chirp by about 20s.

The horn will continue this pattern until the chamber fail latch is reset. The chamber fail latch resets when any one of the followings is active:

- Two consecutive chamber tests pass
- Local smoke alarm
- PTT smoke alarm

After the chamber test is completed, the CHAMBER voltage goes back to its normal standby level.

Chamber test is performed approximately 140s after the loaded Low Battery test.

In a Local Alarm, PTT Alarm or Remote Alarm condition, the chamber test is not performed, and the Low Battery chirping is prohibited.

3.4 Push-to-Test (PTT)

PTT is an event when TEST is activated (V_{IH3}). Release of PTT is an event when TEST is deactivated (V_{IL3}). PTT has different functions for different circumstances. In Standby, PTT tests the unit. Upon start of PTT, the CHAMBER voltage is lowered to a pre-determined level (user programmable) to emulate a Smoke condition. The smoke detection rate increases to once every 250 ms. After three consecutive smoke detections, the unit will go into a Local Alarm condition. In alarm, the smoke detection rate decreases to once every 1s. Upon release of PTT, the unit is immediately reset out of Local Alarm, and the horn is silenced. The chamber voltage goes back to the normal standby level, and the detection rate goes back to once every 10s.

When the unit exits a Local Alarm condition, the alarm memory latch is set. PTT will activate the alarm memory indication if the alarm memory latch is set and if the alarm memory indication function has been enabled. If the alarm memory indication function has not been enabled and the alarm memory latch is set, PTT will test the unit as described above. The release of PTT will always reset the alarm memory latch.

In Standby and Low Battery conditions, PTT tests the unit and RLED will be constantly enabled. This allows the user to easily identify the low battery unit without waiting for 40s to hear a horn chirp. Upon release of PTT, RLED goes back to normal standby pulse rate. The Low Battery HUSH mode is then activated, if this function is enabled.

3.5 Interconnect Operation

The bidirectional IO pin allows the interconnection of multiple detectors. In a Local Alarm condition, this pin is driven high 3.7s after a Local Alarm condition is sensed through a constant current source. Shorting this output to ground will not cause excessive current. The IO is ignored as input during a Local Alarm.

The IO also has an NMOS discharge device that is active for 0.5s after the conclusion of any type of Local Alarm. This device helps to quickly discharge any capacitance associated with the interconnect line.

If a remote active high signal is detected, the device goes into Remote Alarm and the horn will be active. RLED will be off, indicating a Remote Alarm condition. Internal protection circuitry allows the signaling unit to have higher supply voltage than the signaled unit, without excessive current draw.

The interconnect input has a 291 ms maximum digital filter. This allows for interconnection to other types of alarms (CO, for example) that may have a pulsed interconnect signal.

As a user-programmable option, the smart interconnect (smart IO) function can be selected. If the IO input is pulsed high twice with a nominal pulse on time

greater than 37 ms and within 5.4s, a CO Alarm condition is detected, and the CO temporal horn pattern will sound. The CO temporal pattern will sound at least two times, if a CO Alarm condition is detected.

3.6 Reduced Sensitivity Mode (HUSH Mode)

Upon release of PTT, the unit may or may not go into a HUSH mode, depending on the user's selection.

If the hush-in-alarm-only option is selected, then only the release of PTT in a Local Alarm condition can initiate a HUSH mode. Upon release of PTT, the unit is immediately reset out of alarm, and the horn is silenced.

If the hush-in-alarm-only option is not selected, then anytime a release of PTT occurs, the HUSH mode is initiated.

In HUSH mode, the smoke sensitivity is lowered to a pre-determined level, which is user programmable. RLED is turned on for 10 ms every 10s.

The HUSH mode period is user programmable – it can be either 9 minutes or 80s. After this period times out, the unit goes back to its standby sensitivity.

If the unit is currently in a HUSH mode, then PTT will test the unit with the standby sensitivity. Upon release of PTT, a new HUSH mode will be initiated.

As another user-programmable option, HUSH mode can be terminated earlier by a smart hush function. This function allows the HUSH mode to be canceled by either a high smoke alarm, or a remote smoke alarm. High smoke alarm is the local smoke alarm caused by a smoke level that exceeds the reduced sensitivity level.

3.7 Alarm Memory

Alarm memory is a user-programmable option. If a unit has entered a Local Alarm, when exiting that Local Alarm, the alarm memory latch is set. The GLED can be used to visually identify any unit that had previously been in a Local Alarm condition. The GLED is pulsed on three times every 40s. Each GLED pulse is 10 ms long and 1s spaced from the next pulse. This alarm memory indication period can be 0, 24, 48 hours or no limit, depending on the user's selection.

The user will be able to identify a unit with an active alarm memory anytime by PTT. Upon start of PTT, the alarm memory indication will be activated. Depending on the user's selection, it can be 4 Hz horn chirp, 4 Hz GLED pulse, or both. Upon release of PTT, the alarm memory latch will be reset.

Anytime a release of PTT occurs, the alarm memory latch will be reset. The initial visual GLED indication is not displayed if a Low Battery condition exists.

3.8 End-of-Life (EOL) Indicator

The EOL indicator is a user-programmable function. If the EOL indicator function is enabled, then approximately every 15 days of continuous operation, TEOL, the circuit will read an age count stored in EEPROM, and will increment this age. After 10 years of operation, an audible indication will be given to signal that the unit should be replaced. The EOL indicator is the same as the chamber test failure warning.

3.9 Tone Pattern

The smoke alarm tone pattern can be either a temporal pattern, or a continuous pattern, depending on the user's selection. The temporal horn pattern supports the NFPA 72[®] National Fire Alarm and Signaling Code[®] for emergency evacuation signals. The continuous pattern is a 70% duty cycle continuous pattern.

If a CO alarm is detected through the IO, the unit will sound the CO tone pattern. The CO tone pattern consists of 4 horn beeps in every 5.8s. Each horn beep is 100ms long and separated by 100ms.

3.10 Horn Synchronization

The horn synchronization function is programmable by the user.

In an interconnected system, if one unit goes into Local Alarm, other units will also go into Remote Alarm. The IO line is driven high by the origination local smoke unit, and stays high during the alarm.

If the Horn Synchronization function is enabled, at the end of every temporal horn pattern and when the horn is off, the origination unit will drive IO low, then high again. This periodic IO pulsing high and low will cause the remote smoke units to go into and out of the Remote Alarm repeatedly. Each time a unit goes into a Remote Alarm, its timing is reset. The horn sound of all remote smoke units will be synchronized with the horn sound of the origination unit.

A protection circuit ensures that the unit that goes first into a Local Alarm will be the master unit that conducts the horn synchronization. The units that go later into Local Alarm will not drive the IO line. This prevents bus contention problem.

This function works with the temporal tone pattern only.

3.11 Auto Alarm Locate

Auto Alarm Locate (AAL) is also a user-programmable function. To use AAL, the horn synchronization has to be selected first. The purpose of AAL is to let users quickly find the local alarm units just by listening. The local alarm units will sound the temporal pattern without interruption. The remote alarm units will sound the pattern with interruption. Every four temporal patterns (or 16s), the remote units are kept silenced for one pattern (or 4s).

The originating unit conducts the IO cycling. Every four temporal patterns the IO is driven low for one temporal pattern. In the remaining three temporal patterns, the IO is still pulsing to keep the horn synchronized.

The RLED of the origination unit and other local smoke units will be turned on 10 ms every 1s. The RLED of the remote smoke units will be off.

RE46C180

NOTES:

4.0 USER PROGRAMMING MODES

Tables 4-1 to 4-6 show the parameters for user smoke calibration.

TABLE 4-1: PARAMETRIC PROGRAMMING

Parametric Programming	Range	Resolution
Standby Smoke Sensitivity (V_{STD})	2.9 → 6.0V (Note 1)	100 mV (Note 1)
Hysteresis (V_{HYS})	+50 → +225 mV (Note 2)	25 mV (Note 2)
HUSH Smoke Sensitivity (V_{HSH})	-1600 mV → -100 mV (Note 3)	100 mV (Note 3)
CHAMBER Voltage at PTT/Chamber Test ($V_{CHAMBER}$)	2.10 → 6.75V (Note 4)	150 mV (Note 4)

Note 1: V_{STD} listed is based on $V_{DD} = 9V$. The actual range is $(29/90)V_{DD} \rightarrow (60/90)V_{DD}$, resolution is $V_{DD}/90$.

2: V_{HYS} is a positive offset from V_{STD} . The listed value is based on $V_{DD} = 9V$. The actual range is $+(0.5/90)V_{DD} \rightarrow +(2.25/90)V_{DD}$, resolution is $(0.25/90)V_{DD}$.

3: V_{HSH} is a negative offset from V_{STD} . The listed value is based on $V_{DD} = 9V$. The actual range is $-(16/90)V_{DD} \rightarrow -(1/90)V_{DD}$, resolution is $V_{DD}/90$.

4: $V_{CHAMBER}$ listed value is based on $V_{DD} = 9V$. Actual range is $(21/90)V_{DD} \rightarrow (67.5/90)V_{DD}$, resolution is $(1.5/90)V_{DD}$.

TABLE 4-2: STANDBY SENSITIVITY (V_{STD}) PROGRAMMING CONFIGURATION AT $V_{DD} = 9V$

V_{STD} Register STTR [5:1] Configuration					Values
STTR5	STTR4	STTR3	STTR2	STTR1	V_{STD}
0	0	0	0	0	4.5V
0	0	0	0	1	4.6V
0	0	0	1	0	4.7V
0	0	0	1	1	4.8V
0	0	1	0	0	4.9V
0	0	1	0	1	5.0V
0	0	1	1	0	5.1V
0	0	1	1	1	5.2V
0	1	0	0	0	5.3V
0	1	0	0	1	5.4V
0	1	0	1	0	5.5V
0	1	0	1	1	5.6V
0	1	1	0	0	5.7V
0	1	1	0	1	5.8V
0	1	1	1	0	5.9V
0	1	1	1	1	6.0V
1	0	0	0	0	2.9V
1	0	0	0	1	3.0V
1	0	0	1	0	3.1V
1	0	0	1	1	3.2V
1	0	1	0	0	3.3V
1	0	1	0	1	3.4V
1	0	1	1	0	3.5V
1	0	1	1	1	3.6V
1	1	0	0	0	3.7V
1	1	0	0	1	3.8V
1	1	0	1	0	3.9V
1	1	0	1	1	4.0V
1	1	1	0	0	4.1V
1	1	1	0	1	4.2V
1	1	1	1	0	4.3V
1	1	1	1	1	4.4V

RE46C180

TABLE 4-3: HYSTERESIS (V_{HYS}) PROGRAMMING CONFIGURATION AT $V_{DD} = 9V$

V_{HYS} Register HYTR[3:1] Configuration			Values
HYTR3	HYTR2	HYTR1	V_{HYS}
0	0	0	150 mV
0	0	1	175 mV
0	1	0	200 mV
0	1	1	225 mV
1	0	0	50 mV
1	0	1	75 mV
1	1	0	100 mV
1	1	1	125 mV

TABLE 4-4: HUSH SENSITIVITY (V_{HSH}) PROGRAMMING CONFIGURATION AT $V_{DD} = 9V$

V_{HSH} Register TMTR[4:1] Configuration				Values
TMTR4	TMTR3	TMTR2	TMTR1	V_{HSH}
0	0	0	0	$V_{STD} - 800$ mV
0	0	0	1	$V_{STD} - 700$ mV
0	0	1	0	$V_{STD} - 600$ mV
0	0	1	1	$V_{STD} - 500$ mV
0	1	0	0	$V_{STD} - 400$ mV
0	1	0	1	$V_{STD} - 300$ mV
0	1	1	0	$V_{STD} - 200$ mV
0	1	1	1	$V_{STD} - 100$ mV
1	0	0	0	$V_{STD} - 1600$ mV
1	0	0	1	$V_{STD} - 1500$ mV
1	0	1	0	$V_{STD} - 1400$ mV
1	0	1	1	$V_{STD} - 1300$ mV
1	1	0	0	$V_{STD} - 1200$ mV
1	1	0	1	$V_{STD} - 1100$ mV
1	1	1	0	$V_{STD} - 1000$ mV
1	1	1	1	$V_{STD} - 900$ mV

TABLE 4-5: CHAMBER VOLTAGE ($V_{CHAMBER}$) PROGRAMMING CONFIGURATION AT $V_{DD} = 9V$

$V_{CHAMBER}$ Register PTTR[5:1] Configuration					Values
PTTR5	PTTR4	PTTR3	PTTR2	PTTR1	$V_{CHAMBER}$
0	0	0	0	0	4.50V
0	0	0	0	1	4.65V
0	0	0	1	0	4.80V
0	0	0	1	1	4.95V
0	0	1	0	0	5.10V
0	0	1	0	1	5.25V
0	0	1	1	0	5.40V
0	0	1	1	1	5.55V
0	1	0	0	0	5.70V
0	1	0	0	1	5.85V
0	1	0	1	0	6.00V
0	1	0	1	1	6.15V
0	1	1	0	0	6.30V
0	1	1	0	1	6.45V
0	1	1	1	0	6.60V
0	1	1	1	1	6.75V
1	0	0	0	0	2.10V
1	0	0	0	1	2.25V
1	0	0	1	0	2.40V
1	0	0	1	1	2.55V
1	0	1	0	0	2.70V
1	0	1	0	1	2.85V
1	0	1	1	0	3.00V
1	0	1	1	1	3.15V
1	1	0	0	0	3.30V
1	1	0	0	1	3.45V
1	1	0	1	0	3.60V
1	1	0	1	1	3.75V
1	1	1	0	0	3.90V
1	1	1	0	1	4.05V
1	1	1	1	0	4.20V
1	1	1	1	1	4.35V

TABLE 4-6: FEATURE PROGRAMMING

Features	Options
Low Battery Detection Selection	6.9V 7.2V 7.5V 7.8V
10 Year End-of-Life Indicator	Enable/Disable
Smart IO with CO Alarm Sensing	Enable/Disable
Auto Alarm Locate	Enable/Disable
Horn Synchronization	Enable/Disable
Low Battery Hush	Enable/Disable
Alarm Memory Indicator at PTT: Horn Chirping	Enable/Disable
Alarm Memory Indicator at PTT: GLED Flashing	Enable/Disable
Alarm Memory Indicator at Standby Time Out Period	0/24/48 hr or no limit
Alarm Memory	Enable/Disable
HUSH Time Out Period	9 minutes or 80s
Smart HUSH	Enable/Disable
HUSH In Alarm Only	Enable/Disable
HUSH	Enable/Disable
Tone Select	Temporal or Continuous

4.1 Calibration and Programming Procedures

Sixteen separate programming and Test modes are available for user customization. The T2 input is used to enter these modes and step through them. To enter these modes, after power-up, T2 must be driven to V_{DD} and held at that level. To step through the modes, the TEST input must first be driven to V_{DD} . T2 is then clocked. TEST has to be high when clocking T2. Anytime T2 and TEST are both driven to low, the unit will come out of these modes and go back to the normal operation mode. FEED and IO are re-configured to become Test mode inputs. A T2 clock occurs when it switches from V_{SS} to V_{DD} . The Test mode functions are outlined in the [Table 4-7](#).

TABLE 4-7: TEST MODE FUNCTIONS

Mode	Descriptions	T2 Clock	TEST	T2	FEED	IO	T3	TESTOUT
M0 Note 1	Normal Operation	0	PTT/HUSH	0	FEED	IO	Not Used	IO Dump Note 2
TM0	Speedup Mode	1	PTT/HUSH	V_{DD}	CLK	IO	Not Used	IO Dump Note 2
TM1	Load Timer for Spill	2	EOL Timer Clock	V_{DD}	HUSH/LB HUSH Timer Clock	Alarm Mem Timer Clock	Not Used	Not Used
TM2	User Feature Programming	3	ProgData	V_{DD}	ProgClk	ProgEn	Not Used	Not Used
TM3	Horn Test/LED On; IO High/Low	4	HornEnB Note 3	V_{DD}	IOHi En IO Dump EnB HB/HS En Note 4	LEDEn	Not Used	Not Used
TM4	Standby Sen Set	5	SmkCompEnB T3EnB	V_{DD}	CalClk	ReadReg	V_{SEN}	SmkCompOut Note 5
TM5	Hyst Sen Set	6	SmkCompEnB T3EnB	V_{DD}	CalClk	ReadReg	V_{SEN}	SmkCompOut Note 5

Note 1: After power-up, the unit is in M0, the normal operation mode. When in M0, if T2 is driven to V_{DD} , the unit will enter TM0.

2: In M0 and TM0, the digital output TESTOUT is driven by the internal IO dump signal.

3: In TM3, if TEST = V_{SS} , the horn is turned on. IO is in weak pull-down; If TEST = V_{DD} , the horn is off. FEED controls IO and HB/HS.

4: Valid when TEST = V_{DD} ;

5: SmkCompOut – digital comparator output (high if DETECT < V_{SEN} ; low if DETECT > V_{SEN}).

6: LBCompOut – digital comparator output (high if V_{DD} < LB trip point; low if V_{DD} > LB trip point).

RE46C180

TABLE 4-7: TEST MODE FUNCTIONS (CONTINUED)

Mode	Descriptions	T2 Clock	TEST	T2	FEED	IO	T3	TESTOUT
TM6	HUSH Sen Set	7	SmkCompEnB T3EnB	V _{DD}	CalClk	ReadReg	V _{SEN}	SmkCompOut Note 5
TM7	PTT/Chamber Test Set	8	SmkCompEnB T3EnB	V _{DD}	CalClk	ReadReg	V _{SEN}	SmkCompOut Note 5
TM8	Program Calibration	9	Not Used	V _{DD}	Not Used	ProgEn	Not Used	Not Used
TM9	Not Used	10						
TM10	Serial Read/Write Calibration	11	ProgData	V _{DD}	ProgClk	ProgEn	Not Used	Not Used
TM11	Not Used	12						
TM12	Standby Sen Check	13	SmkCompEnB T3EnB	V _{DD}	Not Used	Not Used	V _{SEN}	SmkCompOut Note 5
TM13	Hyst Sen Check	14	SmkCompEnB T3EnB	V _{DD}	Not Used	Not Used	V _{SEN}	SmkCompOut Note 5
TM14	HUSH Sen Check	15	SmkCompEnB T3EnB	V _{DD}	Not Used	Not Used	V _{SEN}	SmkCompOut Note 5
TM15	PTT/Chamber Test CHAMBER Voltage Check	16	SmkCompEnB T3EnB	V _{DD}	Not Used	Not Used	V _{SEN}	SmkCompOut Note 5
TM16	Not Used	17						
TM17	LB Test	18	Not Used	V _{DD}	Not Used	LB Test En RLED En	Not Used	LBCompOut Note 6
TM18	Serial Read/Write Feature and Calibration	19	ProgData	V _{DD}	ProgClk	ProgEn	Not Used	Serial Out
TM19	User EE Lock Bit	20	LockSetEn	V _{DD}	Not used	ProgEn	Not Used	Lock Out

- Note 1:** After power-up, the unit is in M0, the normal operation mode. When in M0, if T2 is driven to V_{DD}, the unit will enter TM0.
- 2:** In M0 and TM0, the digital output TESTOUT is driven by the internal IO dump signal.
- 3:** In TM3, if TEST = V_{SS}, the horn is turned on. IO is in weak pull-down; If TEST = V_{DD}, the horn is off. FEED controls IO and HB/HS.
- 4:** Valid when TEST = V_{DD};
- 5:** SmkCompOut – digital comparator output (high if DETECT < V_{SEN}; low if DETECT > V_{SEN}).
- 6:** LBCompOut – digital comparator output (high if V_{DD} < LB trip point; low if V_{DD} > LB trip point).

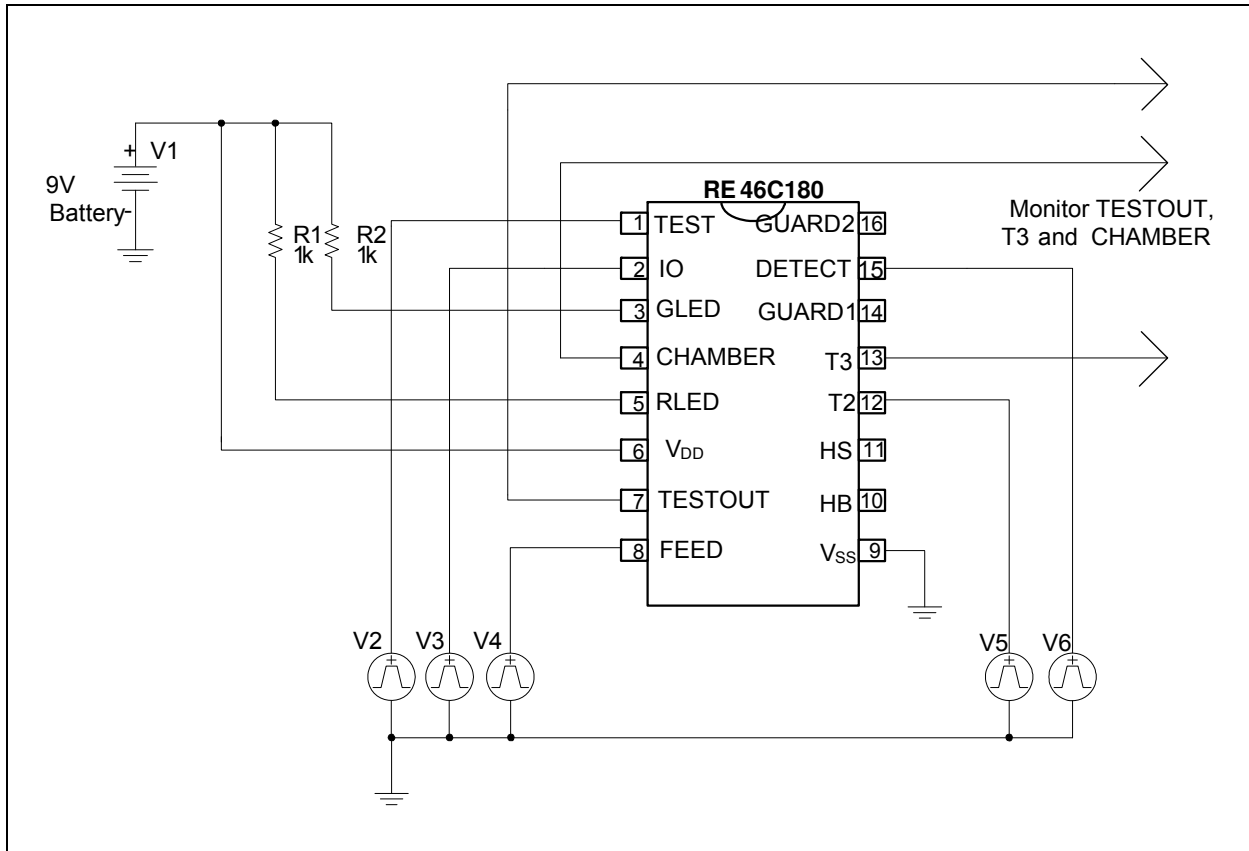

FIGURE 4-1: Nominal Application Circuit for Programming.

4.2 Smoke Calibration

A separate calibration mode is entered for each measurement mode (Normal, Hysteresis, HUSH and PTT/Chamber Test) so that independent limits can be set for each.

In all calibration modes the V_{SEN} voltage, which represents the smoke sensitivity level, can be accessed at T3 output. The SmkCompOut output voltage is the result of the comparison of DETECT and V_{SEN} , and can be accessed at TESTOUT output. The FEED input can be clocked to cycle through the available smoke sensitivity levels. Once the desired smoke sensitivity level is reached, the IO input is pulsed low to high to store the result.

The detailed procedure is described in the following steps:

1. Power up with the bias condition shown in [Figure 4-1](#). At power-up:
 $TEST = IO = FEED = T2 = V_{SS}$,
 $DETECT = V_{DD}$. Now in mode M0.
2. Drive T2 input from V_{SS} to V_{DD} and hold at V_{DD} to enter TM0.
3. Drive TEST from V_{SS} to V_{DD} and hold at V_{DD} .
4. Apply four clock pulses to the T2 input (V_{DD} to V_{SS} and back to V_{DD}) to enter in TM4 mode. This initiates the Calibration mode for the normal sensitivity setting. Drive TEST from V_{DD} to V_{SS} to turn on the smoke comparator and enable the T3 switch. The standby smoke sensitivity V_{SEN} will appear at T3. The smoke comparator output will appear at TESTOUT. Clock FEED to increase or decrease the V_{SEN} levels as needed. The IO input is pulsed low-to-high to save the result.
5. Drive TEST from V_{SS} to V_{DD} and hold at V_{DD} . Apply another clock pulse to the T2 input, to enter in TM5 mode. This initiates the Calibration mode for the hysteresis setting. Drive TEST from V_{DD} to V_{SS} to turn on the smoke comparator and enable the T3 switch. The local alarm smoke sensitivity V_{SEN} will appear at T3. The smoke comparator output will appear at TESTOUT. Clock FEED to increase or decrease the V_{SEN} levels as needed. The IO input is pulsed low-to-high to save the result.

RE46C180

6. Drive TEST from V_{SS} to V_{DD} and hold at V_{DD} . Apply another clock pulse to the T2 input, to enter in TM6 mode. This initiates the calibration mode for the HUSH sensitivity setting. Drive TEST from V_{DD} to V_{SS} to turn on the smoke comparator and enable the T3 switch. The HUSH smoke sensitivity V_{SEN} will appear at T3. The smoke comparator output will appear at TESTOUT. Clock FEED to increase or decrease the V_{SEN} levels as needed. The IO input is pulsed low-to-high to save the result
7. Drive TEST from V_{SS} to V_{DD} and hold at V_{DD} . Apply another clock pulse to the T2 input to enter in TM7 mode. This initiates the calibration mode for the CHAMBER voltage at PTT/Chamber Test. Drive TEST from V_{DD} to V_{SS} to turn on the smoke comparator and enable the T3 switch. The standby smoke sensitivity V_{SEN} will appear at T3. The smoke comparator output will appear at TESTOUT. Clock FEED to increase or decrease the CHAMBER voltages as needed. The IO input is pulsed low-to-high to save the result.
8. After sensitivity settings and CHAMBER voltage calibrations have been made, pulse IO to store all results into memory. Before this step, no settings are stored into memory.

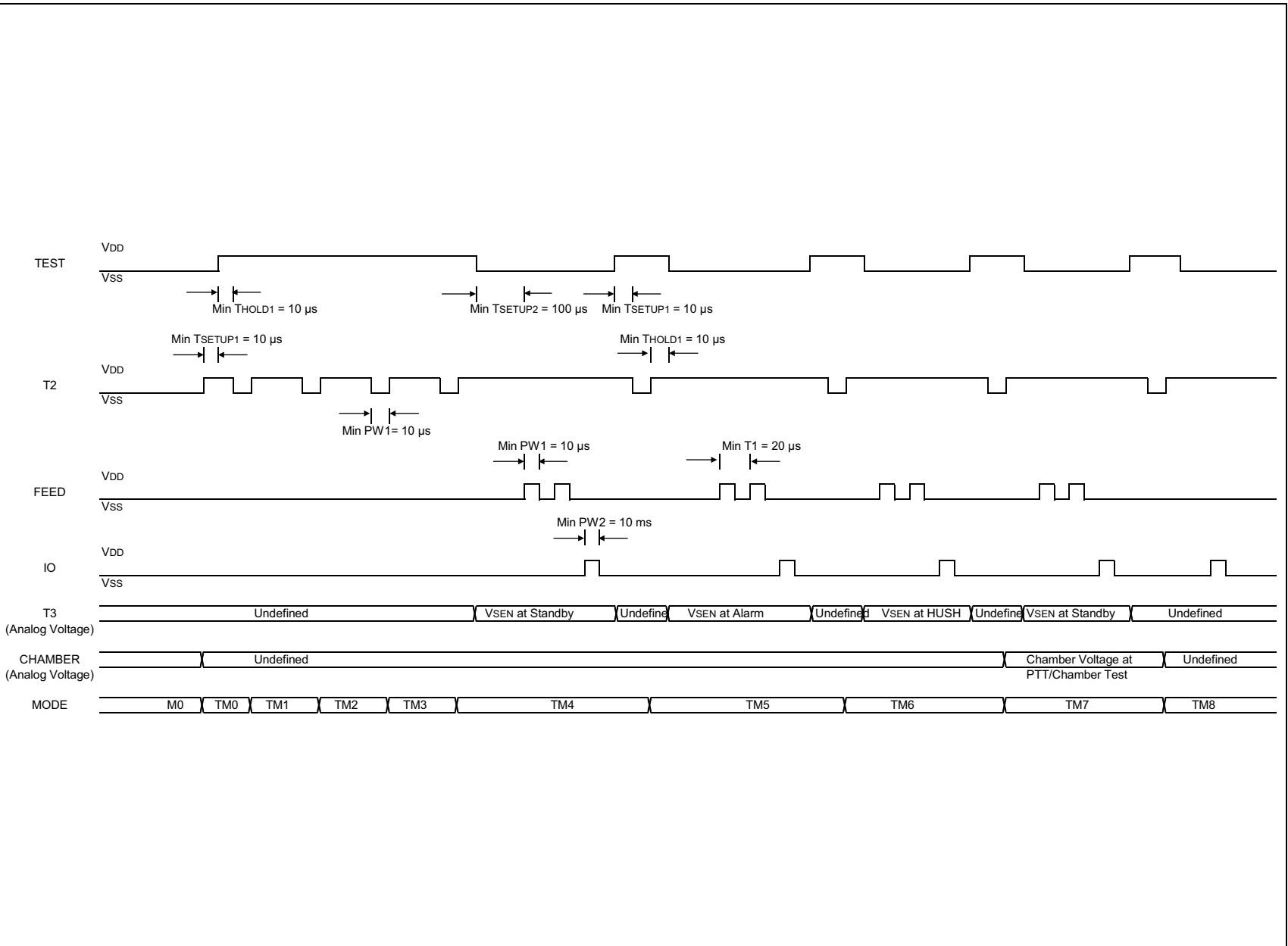

FIGURE 4-2: Timing Diagram for Smoke Calibration (Mode TM4 ~ TM8).

RE46C180

4.3 Serial Read/Write Calibration

As an alternative to the steps in [Section 4.2, Smoke Calibration](#), the sensitivity settings can be entered directly from a Serial Read/Write Calibration mode (if the system has been well characterized).

To enter this mode, follow these steps:

1. Power up with the bias condition shown in [Figure 4-1](#) to enter M0. At power-up:
TEST = IO = FEED = T2 = V_{SS} ,
DETECT = V_{DD} ,
2. Drive T2 input from V_{SS} to V_{DD} and hold at V_{DD} to enter TM0.
3. Drive TEST from V_{SS} to V_{DD} and hold at V_{DD} .
4. Apply 10 clock pulses to the T2 input (V_{DD} to V_{SS} and back to V_{DD}) to enter in TM10 mode. This enables the Serial Read/Write Calibration mode.
5. TEST now acts as a data input (High = V_{DD} , Low = V_{SS}). FEED acts as the clock input (High = V_{DD} , Low = V_{SS}). Clock in the sensitivity settings.

The data sequence should be as follows:

- 5 bit Standby Sensitivity (LSB first)
 - 3 bit Hysteresis (LSB first)
 - 4 bit HUSH Sensitivity (LSB first)
 - 5 bit CHAMBER voltage in PTT/Chamber Test (LSB first)
6. After all 17 bits have been entered, pulse IO to store into the EEPROM memory.

REGISTER 4-1: CALIBRATION CONFIGURATION REGISTER

	W-x
	PTTR5
	bit 17

W-x	W-x	W-x	W-x	W-x	W-x	W-x	W-x
PTTR4	PTTR3	PTTR2	PTTR1	TMTR4	TMTR3	TMTR2	TMTR1
bit 16							bit 8

W-x	W-x	W-x	W-x	W-x	W-x	W-x	W-x
HYTR3	HYTR2	HYTR1	STTR5	STTR4	STTR3	STTR2	STTR1
bit 8							bit 1

Legend:

R = Readable bit	W = Writable bit	U = Unimplemented bit, read as '0'
-n = Value at POR	'1' = Bit is set	'0' = Bit is cleared x = Bit is unknown

bit 17 **PTTR5**: MSB (See [Table 4-5](#))
bit 16 **PTTR4**: 4SB
bit 15 **PTTR3**: 3SB
bit 14 **PTTR2**: 2SB
bit 13 **PTTR1**: LSB
bit 12 **TMTR4**: MSB (See [Table 4-4](#))
bit 11 **TMTR3**: 3SB
bit 10 **TMTR2**: 2SB
bit 9 **TMTR1**: LSB
bit 8 **HYTR3**: MSB (See [Table 4-3](#))
bit 7 **HYTR2**: 2SB
bit 6 **HYTR1**: LSB
bit 5 **STTR5**: MSB (See [Table 4-2](#))
bit 4 **STTR4**: 4SB
bit 3 **STTR3**: 3SB
bit 2 **STTR2**: 2SB
bit 1 **STTR1**: LSB

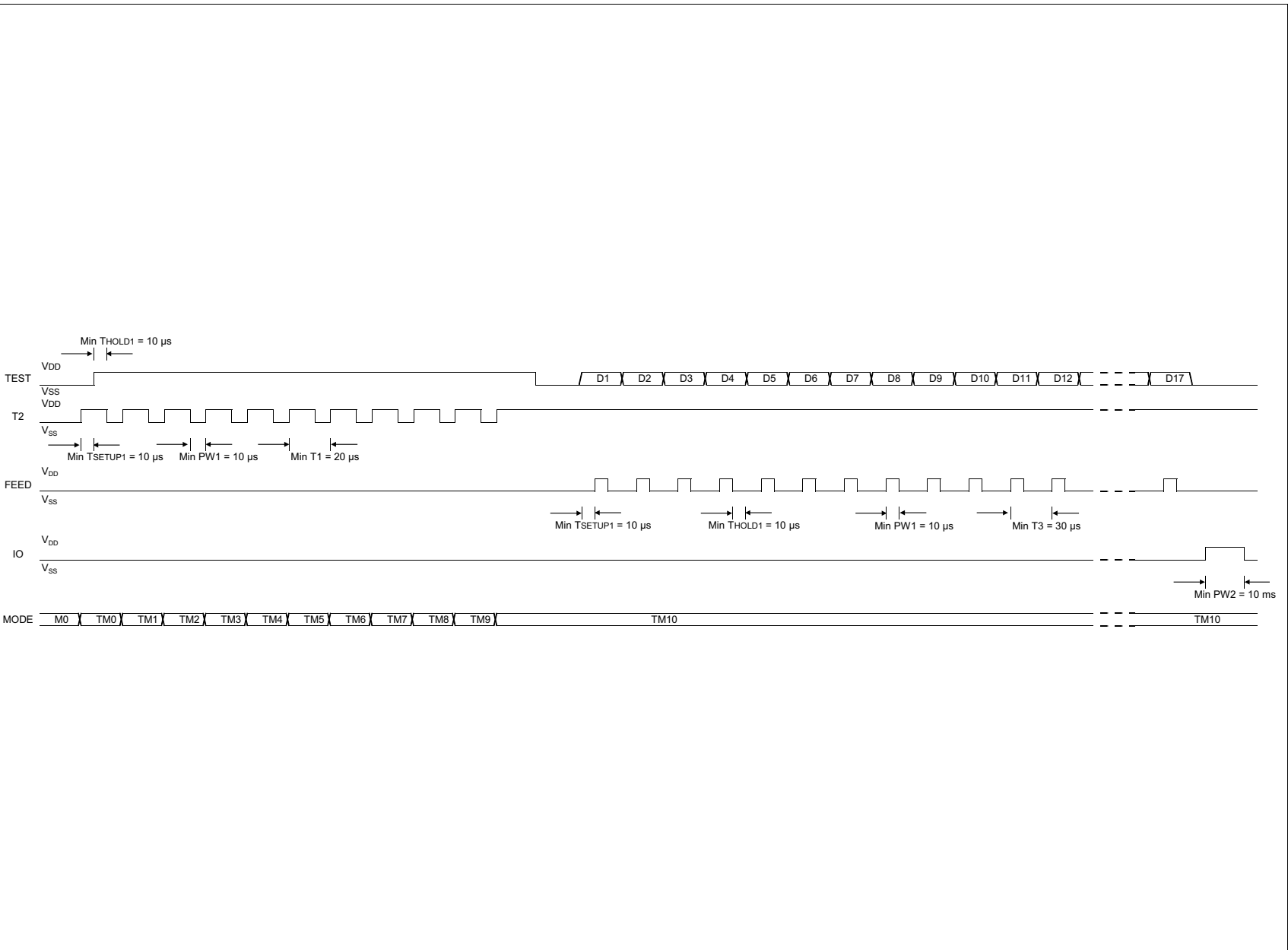

FIGURE 4-3: Timing Diagram for Mode TM10.

4.4 User Feature Selections

User feature selections can be clocked in serially using TEST as data input, and FEED, as a clock input, then stored in the internal EEPROM.

The detailed steps are as follows:

1. Power up with the bias condition shown in [Figure 4-1](#). At power-up:
TEST = IO = FEED = T2 = V_{SS},
DETECT = V_{DD}. Now in mode M0.
2. Drive T2 input from V_{SS} to V_{DD} and hold at V_{DD} to enter TM0.
3. Drive TEST from V_{SS} to V_{DD} and hold at V_{DD}.
4. Apply two clock pulses to the T2 input (V_{DD} to V_{SS} and then back to V_{DD}) to enter in TM2.
5. Using TEST as data and FEED as clock, shift in values of 18 bits as selected from [Register 4-2](#).
6. After shifting in data, pull IO input to V_{DD}, then V_{SS} (minimum pulse-width of 10 ms) to store shift register contents in the memory.
7. If any changes are required, power down the part and return to Step 1. All bit values must be reentered.

REGISTER 4-2: USER FEATURE CONFIGURATION REGISTER

	U	W-x
	—	LBTR2
	bit 18	bit 17

W-x	W-x	W-x	W-x	W-x	W-x	W-x	W-x
LBTR1	EOLEn	COEn	NoAAL	SyncEn	LBHshEn	AMHCEn	AMLEDEn
bit 16							bit 8

W-x	W-x	W-x	W-x	W-x	W-x	W-x	W-x
AMTO2	AMTO1	AMEn	ShrTO	Smrth	HIAO	HushEnB	TSEL
bit 8							bit 1

Legend:

R = Readable bit	W = Writable bit	U = Unimplemented bit, read as '0'
-n = Value at POR	'1' = Bit is set	'0' = Bit is cleared
		x = Bit is unknown

- bit 18 **Unimplemented:** Read as 'x'
- bit 17 **LBTR2:** MSB
- bit 16 **LBTR1:** LSB
 - 00 = 7.5V
 - 01 = 7.8V
 - 10 = 6.9V
 - 11 = 7.2V
- bit 15 **EOLEn:** End-of-Life Indicator Enable Bit
 - 1 = Enable
 - 0 = Disable
- bit 14 **COEn:** CO Alarm Function (Smart IO) Enable Bit
 - 1 = Enable
 - 0 = Disable
- bit 13 **NoAAL:** Auto Alarm Locate Disable Bit
 - 1 = AAL is Disabled
 - 0 = AAL is Enabled
- bit 12 **SyncEn:** Horn Synchronization Enable Bit
 - 1 = Enable
 - 0 = Disable

RE46C180

REGISTER 4-2: USER FEATURE CONFIGURATION REGISTER (CONTINUED)

bit 11	LBHshEn: Low Battery Hush Enable Bit 1 = Enable 0 = Disable
bit 10	AMHCEn: Alarm Memory PTT Indicator Horn Chirp Enable Bit 1 = Enable 0 = Disable
bit 9	AMLEDEn: Alarm Memory PTT Indicator LED Flashing Enable Bit 1 = Enable 0 = Disable
bit 8	AMTO2: MSB
bit 7	AMTO1: LSB 00 = 24 Hours Timeout 01 = 48 Hours Timeout 10 = 0 Hour Timeout 11 = Never Timeout
bit 6	AMEn: Alarm Memory Enable Bit 1 = Enable 0 = Disable
bit 5	ShrTO: HUSH Timer Time Out Select Bit 1 = 80 seconds 0 = 9 minutes
bit 4	SmrtH: Smart HUSH Bit 1 = Enable (Hush is canceled by either high smoke, or remote smoke) 0 = Disable (Hush is never canceled until timeout)
bit 3	HIAO: HUSH-in-Alarm -Only Bit 1 = Enable (Hush is activated upon release of PTT during local smoke only) 0 = Disable (Hush is activated upon release of PTT at anytime)
bit 2	HushEnB: HUSH Enable Bit 1 = Enable (Hush is disabled) 0 = Disable (Hush is enabled)
bit 1	TSEL: Tone Select Bit 1 = Continuous Tone Pattern 0 = Temporal Tone Pattern

The minimum pulse-width for FEED is 10 μ s, while the minimum pulse-width for TEST is 100 μ s.

For example, for the following options, the sequence would be:

Data	–	X	1	0	1	1	1	1	0	1
Bit	–	18	17	16	15	14	13	12	11	10
Data	–	0	0	0	1	0	0	1	0	0
Bit	–	9	8	7	6	5	4	3	2	1

Low battery Trip Point	=	6.9V
End of Life Enable	=	Yes
CO Enable	=	Yes
Auto Alarm Locate Disable	=	Yes
Horn Synchronization Enable	=	Yes
Low Battery Hush Enable	=	No

Alarm Memory PTT Indicator Horn Chirp Enable	=	Yes
Alarm Memory PTT Indicator LED Flashing Enable	=	No
Alarm memory LED indicator time out	=	24 hours
Alarm Memory Enable	=	Yes
HUSH time out	=	9 minutes
Smart HUSH	=	No
Hush in alarm only	=	Yes
Hush Enable	=	Yes
Tone Select	=	Temporal

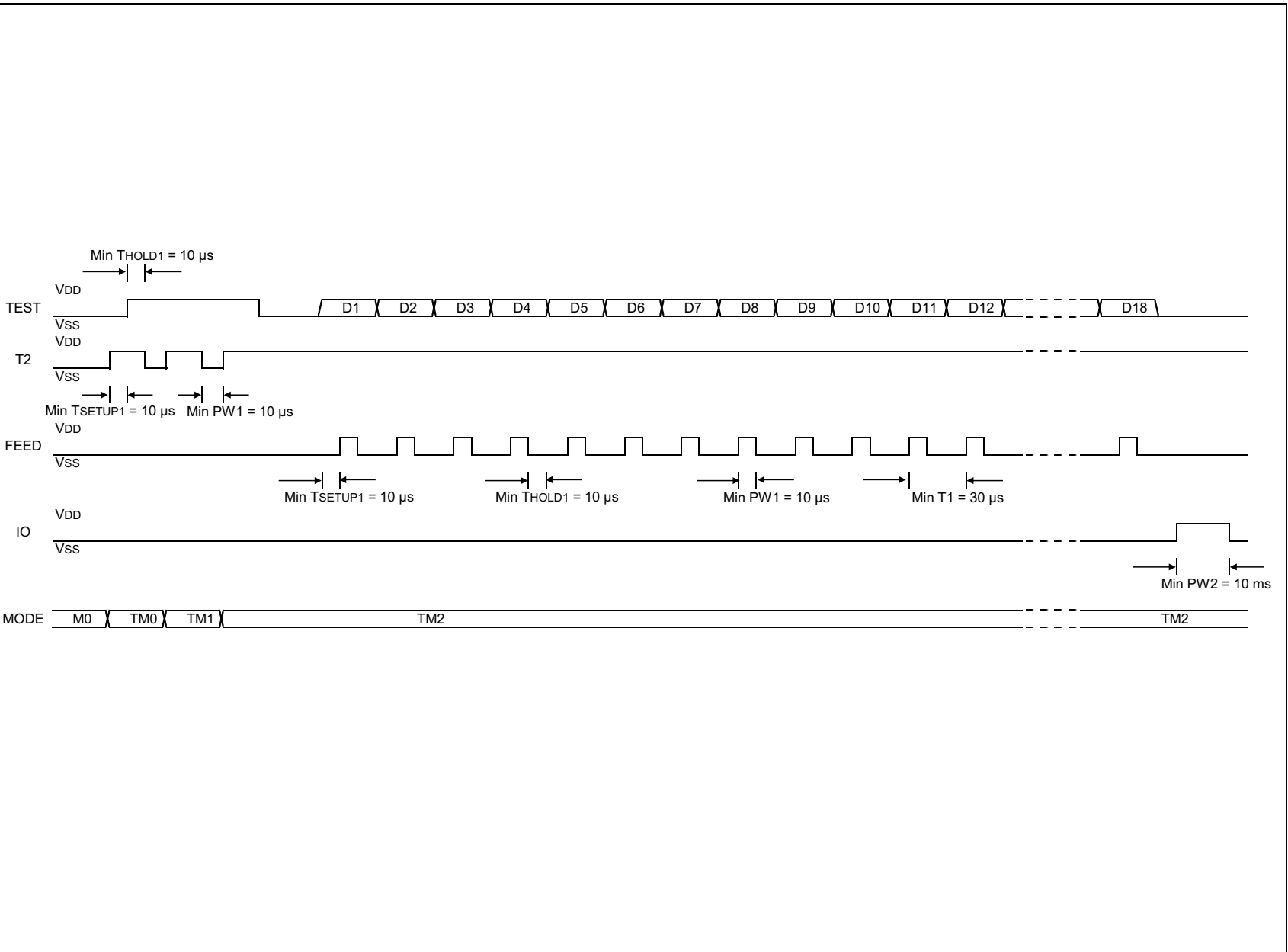

FIGURE 4-4: Timing Diagram for Mode TM2.

RE46C180

4.5 Sensitivity Verification

After all sensitivity levels and CHAMBER voltage at PTT/Chamber Test have been entered and stored into the memory, additional Test modes are available to verify if the sensitivities are functioning as expected.

[Table 4-8](#) describes several verification tests.

TABLE 4-8: SENSITIVITY VERIFICATION DESCRIPTION

Sensitivity	Test Description
Standby Sensitivity	Clock T2 to Mode TM12 (12 clocks). With appropriate smoke level in the chamber, pull TEST to V_{SS} and hold for at least 1 ms. The TESTOUT output will indicate the detection status (High = smoke detected).
Hysteresis	Clock T2 to Mode TM13 (13 clocks). Pulse TEST and monitor TESTOUT.
HUSH Sensitivity	Clock T2 to Mode TM14 (14 clocks). Pulse TEST and monitor TESTOUT.
CHAMBER voltage at PTT/Chamber Test	Clock T2 to Mode TM15 (15 clocks). Pulse TEST and monitor TESTOUT.

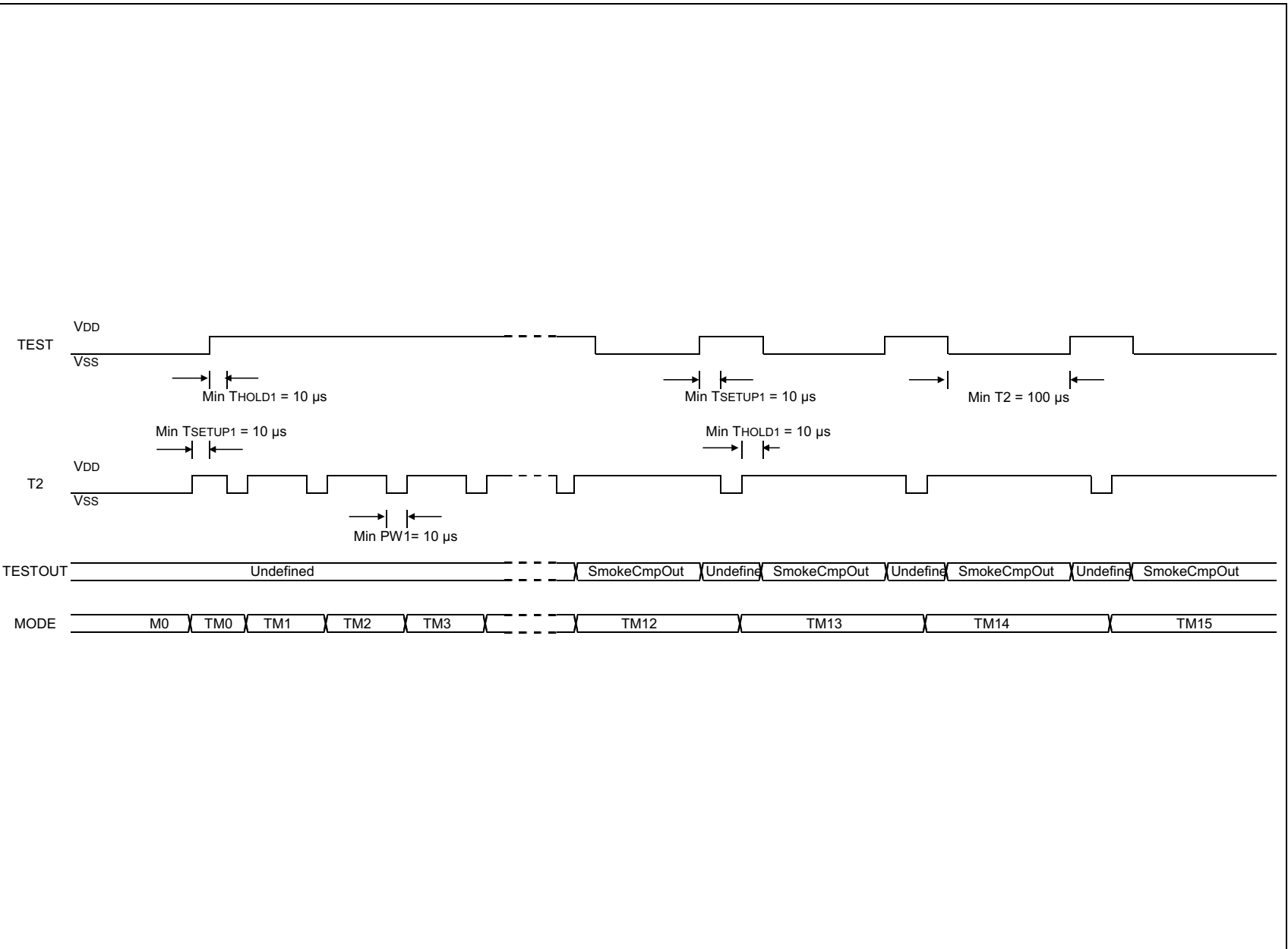

FIGURE 4-5: Timing Diagram for Sensitivity Verification in Mode TM12 ~ TM15.

RE46C180

4.6 Serial Read/Write Calibration and User Features

As an alternative to the steps in [Section 4.2, Smoke Calibration](#) and [Section 4.4, User Feature Selections](#), the sensitivity settings and user feature selections can be entered directly from a Serial Read/Write Calibration mode.

To enter this mode, follow these steps:

- Power up with the bias condition shown in [Figure 4-1](#) to enter M0. At power-up:
TEST = IO = FEED = T2 = V_{SS},
DETECT = V_{DD}.
- Drive T2 input from V_{SS} to V_{DD} and hold at V_{DD} to enter TM0.
- Drive TEST from V_{SS} to V_{DD} and hold at V_{DD}.

- Apply 18 clock pulses to the T2 input (V_{DD} to V_{SS} and then back to V_{DD}) to enter in TM18 mode. This enables the Serial Read/Write Calibration and User Features modes.
- TEST now acts as a data input (High = V_{DD}, Low = V_{SS}). FEED acts as the clock input (High = V_{DD}, Low = V_{SS}). Clock in the sensitivity settings. The data sequence should be as follows:
D1 ~ D18 User Features (18 bits, LSB first)
D19 ~ D35 Calibration (17 bits, LSB First)
- After all 35 bits have been entered, pulse IO to store into the EEPROM memory.

REGISTER 4-3: SERIAL READ/WRITE REGISTER

	W-x	W-x	W-x
	PTTR5	PTTR4	PTTR3
	bit 35		bit 33

W-x	W-x	W-x	W-x	W-x	W-x	W-x	W-x
PTTR2	PTTR1	TMTR4	TMTR3	TMTR2	TMTR1	HYTR3	HYTR2
bit 32							bit 25

W-x	W-x	W-x	W-x	W-x	W-x	U	W-x
HYTR1	STTR5	STTR4	STTR3	STTR2	STTR1	—	LBTR2
bit 24							bit 17

W-x	W-x	W-x	W-x	W-x	W-x	W-x	W-x
LBTR1	EOLEn	COEn	NoAAL	SyncEn	LBHshEn	AMHCEn	AMLEDEn
bit 16							bit 8

W-x	W-x	W-x	W-x	W-x	W-x	W-x	W-x
AMTO2	AMTO1	AMEn	ShrTO	SmrH	HIAO	HushEnB	TSEL
bit 8							bit 1

Legend:

R = Readable bit W = Writable bit U = Unimplemented bit, read as '0'
 -n = Value at POR '1' = Bit is set '0' = Bit is cleared x = Bit is unknown

- bit 35 **PTTR5:** MSB (See [Table 4-5](#))
- bit 34 **PTTR4:** 4SB
- bit 33 **PTTR3:** 3SB
- bit 32 **PTTR2:** 2SB
- bit 31 **PTTR1:** LSB
- bit 30 **TMTR4:** MSB (See [Table 4-4](#))

REGISTER 4-3: SERIAL READ/WRITE REGISTER (CONTINUED)

bit 29	TMTR3: 3SB
bit 28	TMTR2: 2SB
bit 27	TMTR1: LSB
bit 26	HYTR3: MSB (See Table 4-3)
bit 25	HYTR2: 2SB
bit 24	HYTR1: LSB
bit 23	STTR5: MSB (See Table 4-2)
bit 22	STTR4: 4SB
bit 21	STTR3: 3SB
bit 20	STTR2: 2SB
bit 19	STTR1: LSB
bit 18	Unimplemented: Read as 'x'
bit 17	LBTR2: MSB
bit 16	LBTR1: LSB 00 = 7.5V 01 = 7.8V 10 = 6.9V 11 = 7.2V
bit 15	EOLEn: End-of-Life Indicator Enable Bit 1 = Enable 0 = Disable
bit 14	COEn: CO Alarm Function (Smart IO) Enable Bit 1 = Enable 0 = Disable
bit 13	NoAAL: Auto Alarm Locate Disable Bit 1 = AAL is Disabled 0 = AAL is Enabled
bit 12	SyncEn: Horn Synchronization Enable Bit 1 = Enable 0 = Disable
bit 11	LBHshEn: Low Battery Hush Enable Bit 1 = Enable 0 = Disable
bit 10	AMHCEn: Alarm Memory PTT Indicator Horn Chirp Enable Bit 1 = Enable 0 = Disable
bit 9	AMLEDEn: Alarm Memory PTT Indicator LED Flashing Enable Bit 1 = Enable 0 = Disable
bit 8	AMTO2: MSB
bit 7	AMTO1: LSB 00 = 24 Hours Timeout 01 = 48 Hours Timeout 10 = 0 Hours Timeout 11 = Never Timeout
bit 6	AMEn: Alarm Memory Enable Bit 1 = Enable 0 = Disable

RE46C180

REGISTER 4-3: SERIAL READ/WRITE REGISTER (CONTINUED)

- bit 5 **ShrTO:** HUSH Timer Time Out Select Bit
1 = 80 secondse
0 = 9 minutes
- bit 4 **SmrtH:** Smart HUSH Bit
1 = Enable (Hush is canceled by either high smoke, or remote smoke)
0 = Disable (Hush is never canceled until timeout)
- bit 3 **HIAO:** HUSH-in-Alarm-Only Bit
1 = Enable (Hush is activated upon release of PTT during local smoke only)
0 = Disable (Hush is activated upon release of PTT at anytime)
- bit 2 **HushEnB:** HUSH Enable Bit
1 = Enable (Hush is disabled)
0 = Disable (Hush is enabled)
- bit 1 **TSEL:** Tone Select Bit
1 = Continuous Tone Pattern
0 = Temporal Tone Pattern

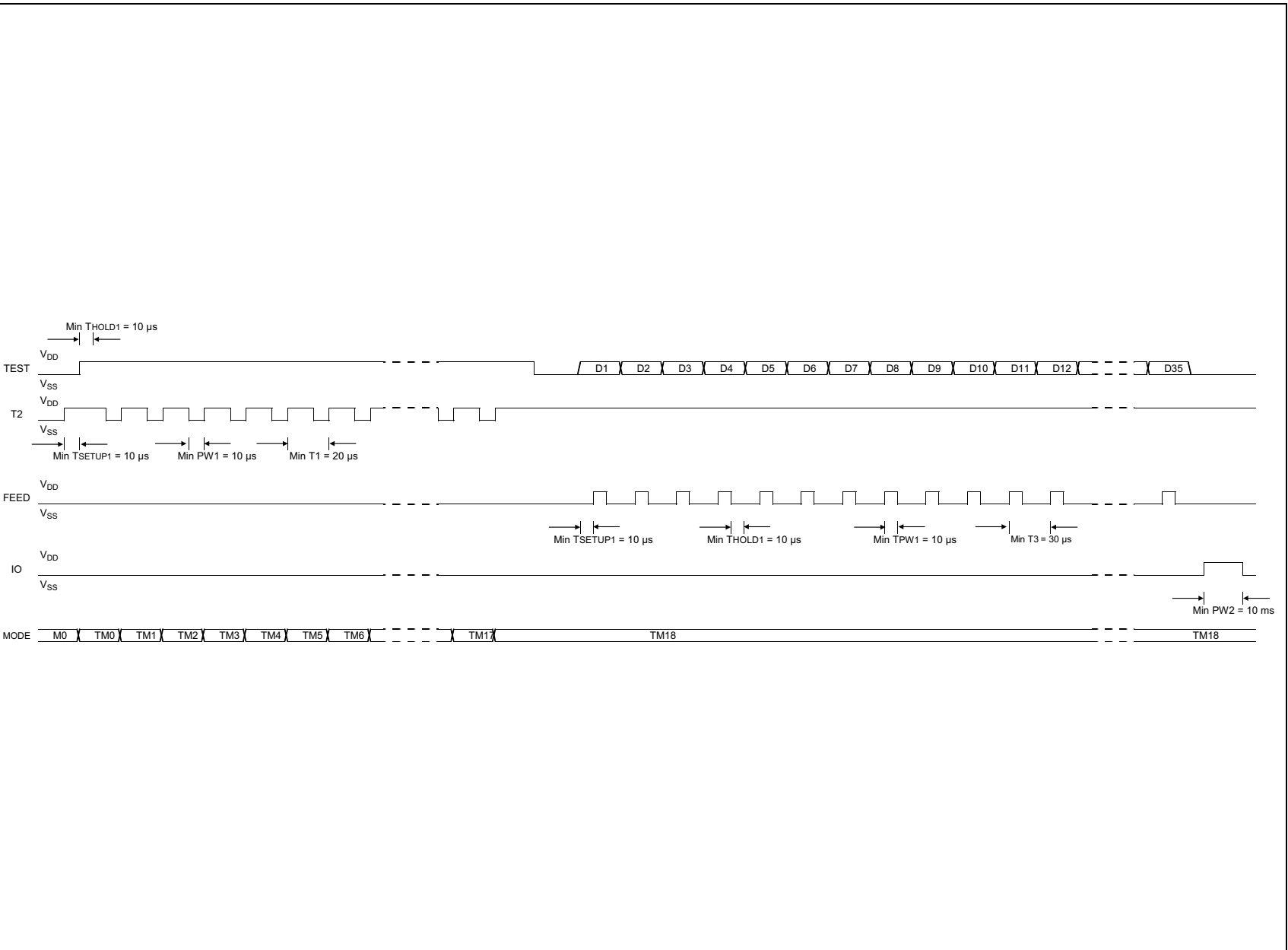

FIGURE 4-6: Timing Diagram for Serial Read/Write Calibration and User Features in Mode TM18.

RE46C180

4.7 Horn Test

Test mode TM3 allows the horn to be enabled indefinitely for audibility testing.

To enter this mode, follow the next steps:

1. Power up with the bias condition shown in [Figure 4-1](#) to enter M0. At power-up:
TEST = IO = FEED = T2 = V_{SS} ,
DETECT = V_{DD} .
2. Drive T2 input from V_{SS} to V_{DD} and hold at V_{DD} to enter TM0.
3. Drive TEST from V_{SS} to V_{DD} and hold at V_{DD} .
4. Apply three clock pulses to the T2 input (V_{DD} to V_{SS} and then back to V_{DD}) to enter in TM3 mode.
5. Drive TEST from V_{DD} to V_{SS} to enable the horn.

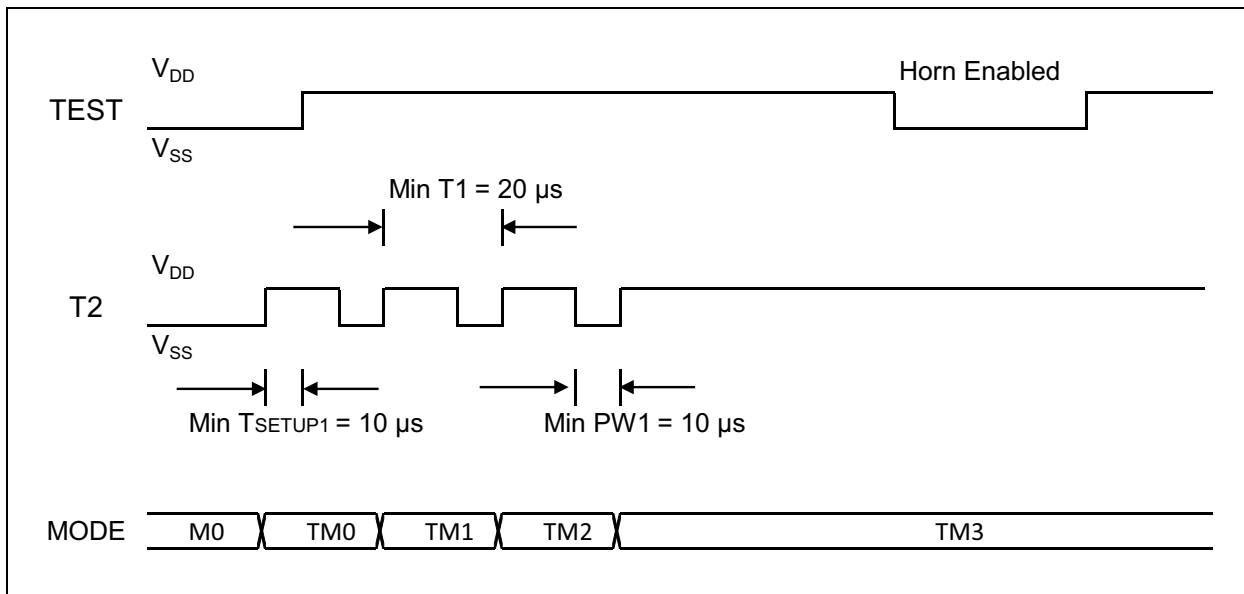

FIGURE 4-7: Timing Diagram for Horn Test in Mode TM3.

4.8 Low Battery Test

Test mode TM17 allows the low battery trip point to be tested. To enter this mode, follow these steps:

1. Power up with the bias condition shown in [Figure 4-1](#) to enter M0. At power-up:
 $TEST = IO = FEED = T2 = V_{SS}$,
 $DETECT = V_{DD}$.
2. Drive T2 input from V_{SS} to V_{DD} and hold at V_{DD} to enter TM0.
3. Drive TEST from V_{SS} to V_{DD} and hold at V_{DD} .
4. Apply 17 clock pulses to the T2 input (V_{DD} to V_{SS} and then back to V_{DD}) to enter in TM17 mode.
5. Drive IO from V_{SS} to V_{DD} to enable the low battery testing and turn on the RLED. Sweep V_{DD} from high to low and monitor TESTOUT output. The TESTOUT output will indicate the Low Battery status (High = Low Battery detected).

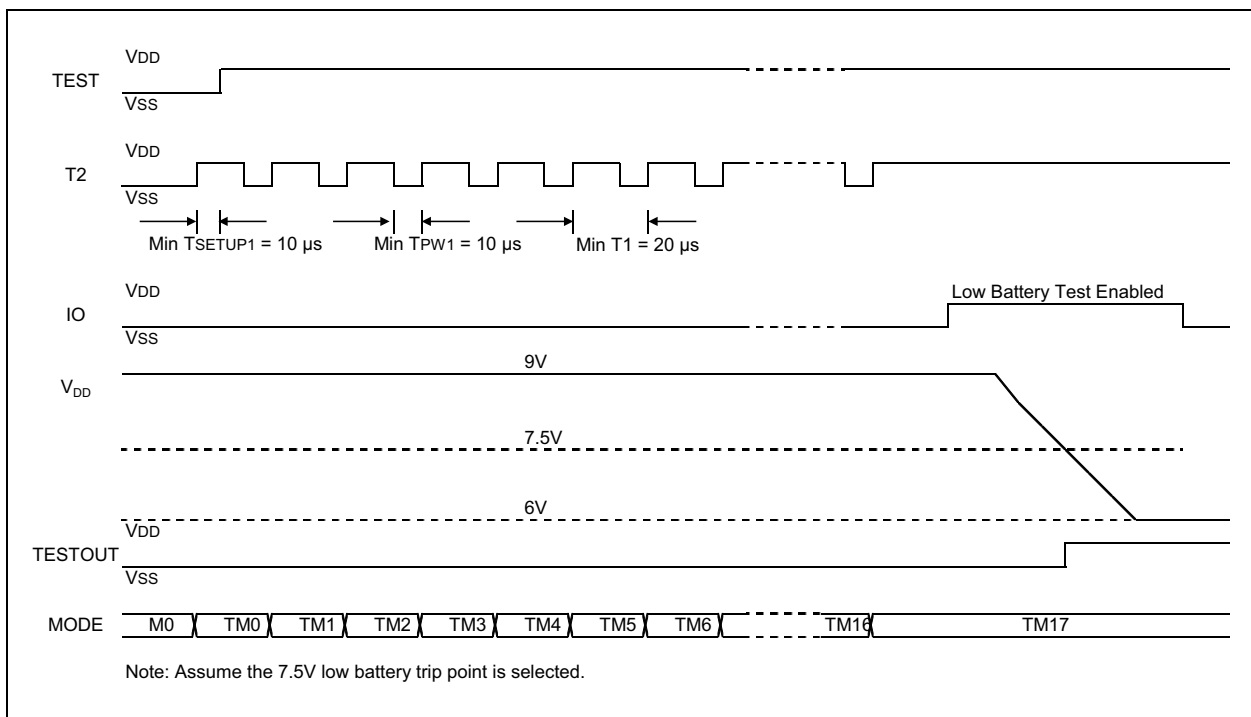

FIGURE 4-8: Timing Diagram for Low Battery Test in Mode TM17.

RE46C180

4.9 User Lock Bit Programming

Test mode TM19 allows users to program the user EE lock bit. Once the user EE lock bit is set, the programmed user EE data can not be changed unless the lock bit is reset.

To enter this mode, follow these steps:

1. Power up with the bias condition shown in [Figure 4-1](#) to enter M0. At power-up:
TEST = IO = FEED = T2 = V_{SS},
DETECT = V_{DD}.
2. Drive T2 input from V_{SS} to V_{DD} and hold at V_{DD} to enter TM0.
3. Drive TEST from V_{SS} to V_{DD} and hold at V_{DD}.
4. Apply 19 clock pulses to the T2 input (V_{DD} to V_{SS} and then back to V_{DD}) to enter in TM19 mode.
5. Hold TEST at V_{DD} and pulse IO once to set the lock bit and store into the EEPROM memory.
6. To reset the lock bit from Step 5, drive TEST to V_{SS} and pulse IO once.

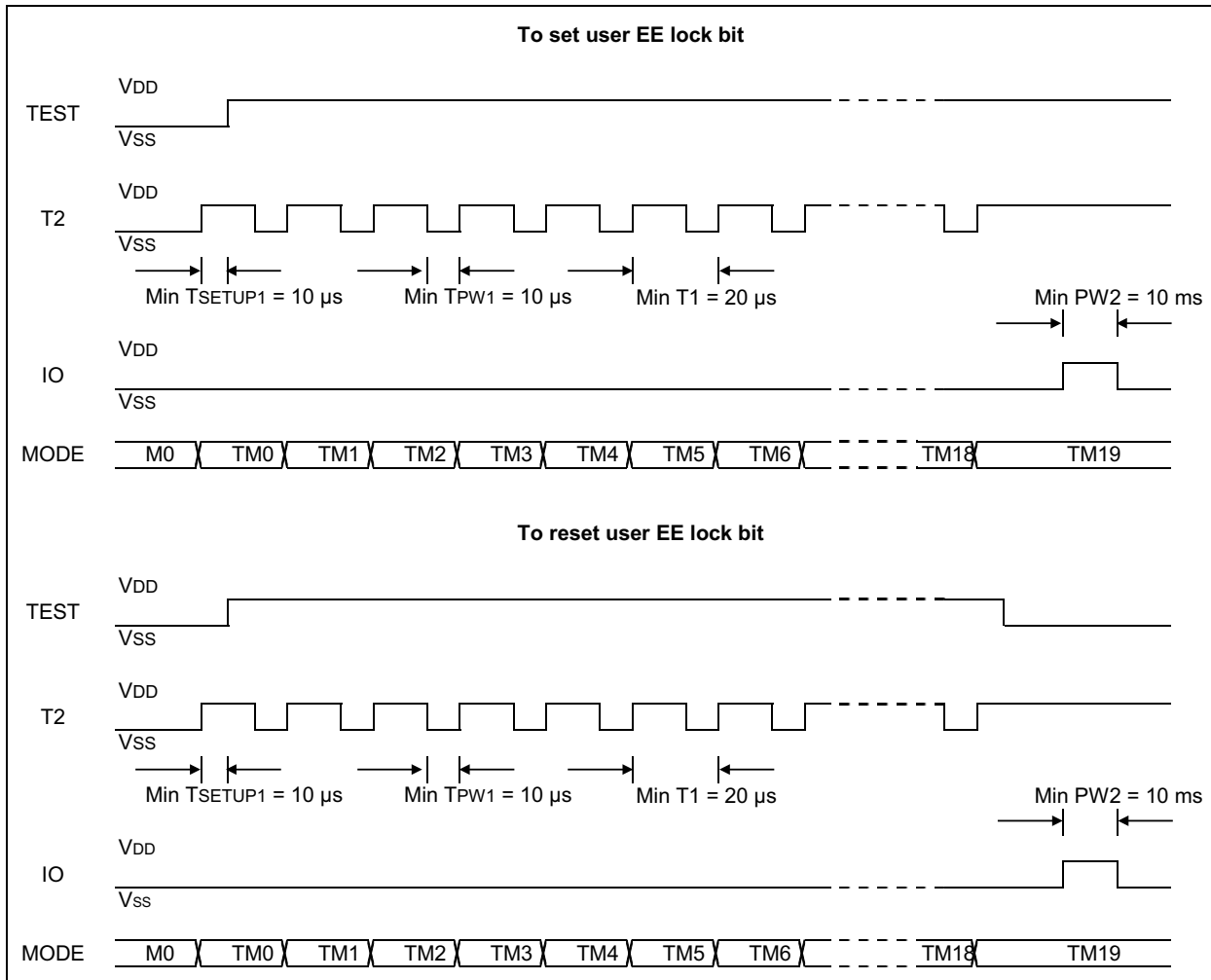

FIGURE 4-9: Timing Diagram for User Lock Bit Programming in Mode TM19

5.0 APPLICATION NOTES

5.1 Standby Current Calculation

A calculation of the standby current is shown in [Table 5-1](#), based on the following conditions:

V_{DD}	=	9V
LED current in loaded battery check	=	10 mA
EOLen	=	1

TABLE 5-1: STANDBY CURRENT CALCULATION

I_{DD} Component	Current (μ A)	Duration (s)	Period (s)	Factor	Average Current (μ A)
Fixed I_{DD}	3.8	Always	Always	1	3.8
Smoke Check	9.6	0.005	10	0.0005	0.0048
Low Battery Check (unloaded)	21.4	0.01	80	0.00013	0.0028
Low Battery Check (loaded)	10000	0.01	320	3.10E-05	0.31
Chamber Test (smoke check)	9.6	0.005	320	1.60E-05	0.00015
Chamber Test (chamber low)	3.2	3.7	320	0.012	0.038
End-of-Life (reading EE and counting)	35	0.14	1310400	1.10E-07	3.74E-06
End-of-Life (writing EE)	100	0.01	1310400	7.40E-09	7.63E-07
Total					4.16

5.1.1 FIXED I_{DD}

The fixed I_{DD} is the current from the constantly active internal oscillator, bias circuit and guard amplifier.

5.1.2 SMOKE CHECK

The current draw from the smoke detection circuitry during the 5 ms smoke check period.

5.1.3 LOW BATTERY CHECK (UNLOADED)

The current drawn by the low battery detection circuitry during the 10 ms unloaded low battery check period.

5.1.4 LOW BATTERY CHECK (LOADED)

The current drawn by the RLED during the 10 ms loaded low battery check period.

5.1.5 CHAMBER TEST (SMOKE CHECK)

The current drawn by the smoke detection circuitry during the 5 ms smoke check period, while the chamber is pulled low.

5.1.6 CHAMBER TEST (CHAMBER LOW)

The current drawn to pull the chamber low when the chamber test is performed.

5.1.7 END-OF-LIFE (READING EE AND COUNTING)

The current drawn to read EOL bits from EE and then increase by 1.

5.1.8 END-OF-LIFE (WRITING EE)

The current drawn to write EOL bits back to EE.

5.1.9 TOTAL CURRENT

The average total current drawn in Standby

RE46C180

5.2 FUNCTIONAL TIMING DIAGRAMS

Figures 5-1 to 5-8 show the timing diagrams for the smoke detector functions described in [Section 3.0, Device Descriptions](#).

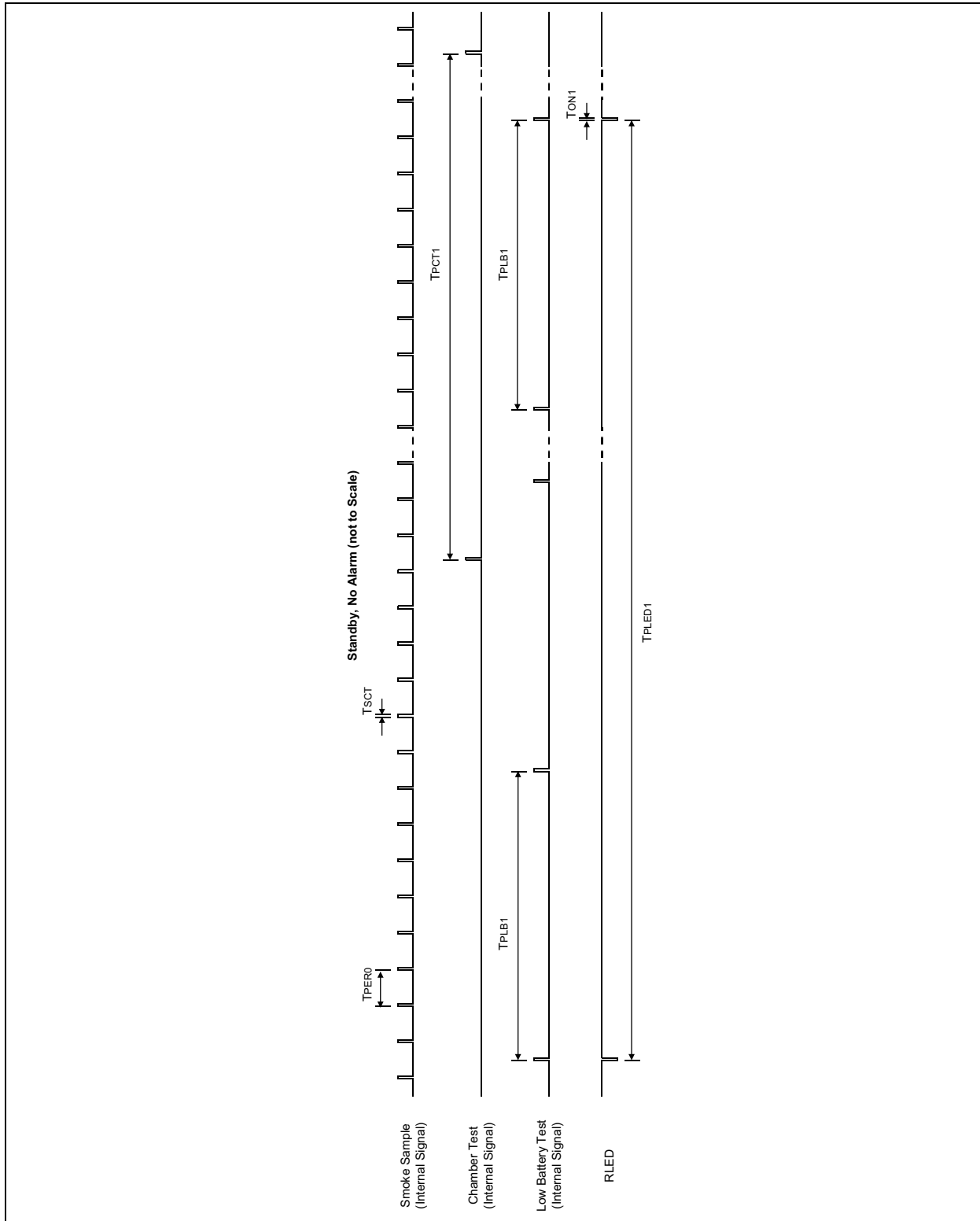

FIGURE 5-1: Timing Diagram – Standby, No Alarm.

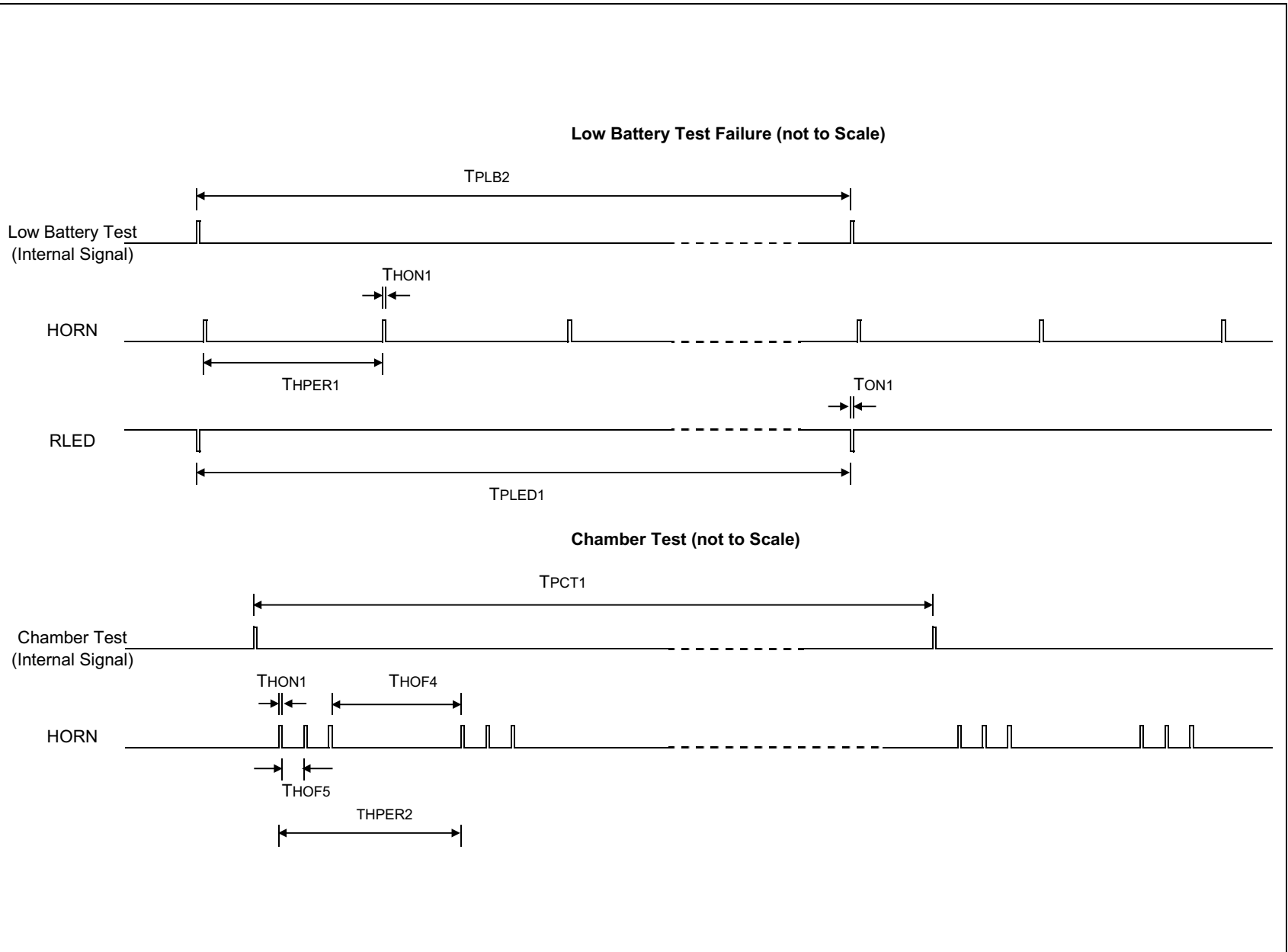

FIGURE 5-2: Timing Diagram – Low Battery Test Failure and Chamber Test Failure.

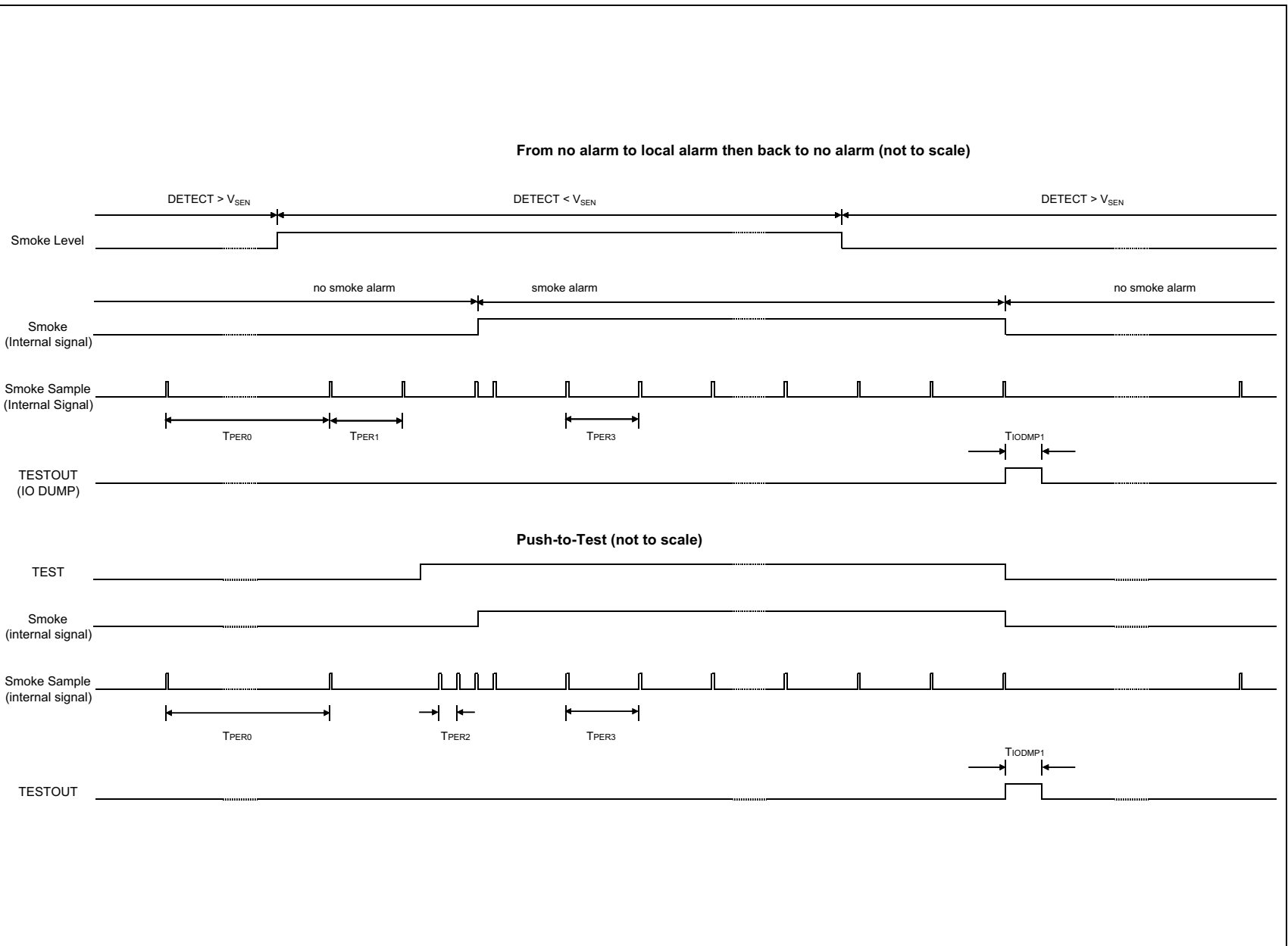

FIGURE 5-3: *Timing Diagram – From Standby to Local Smoke and Push-To-Test.*

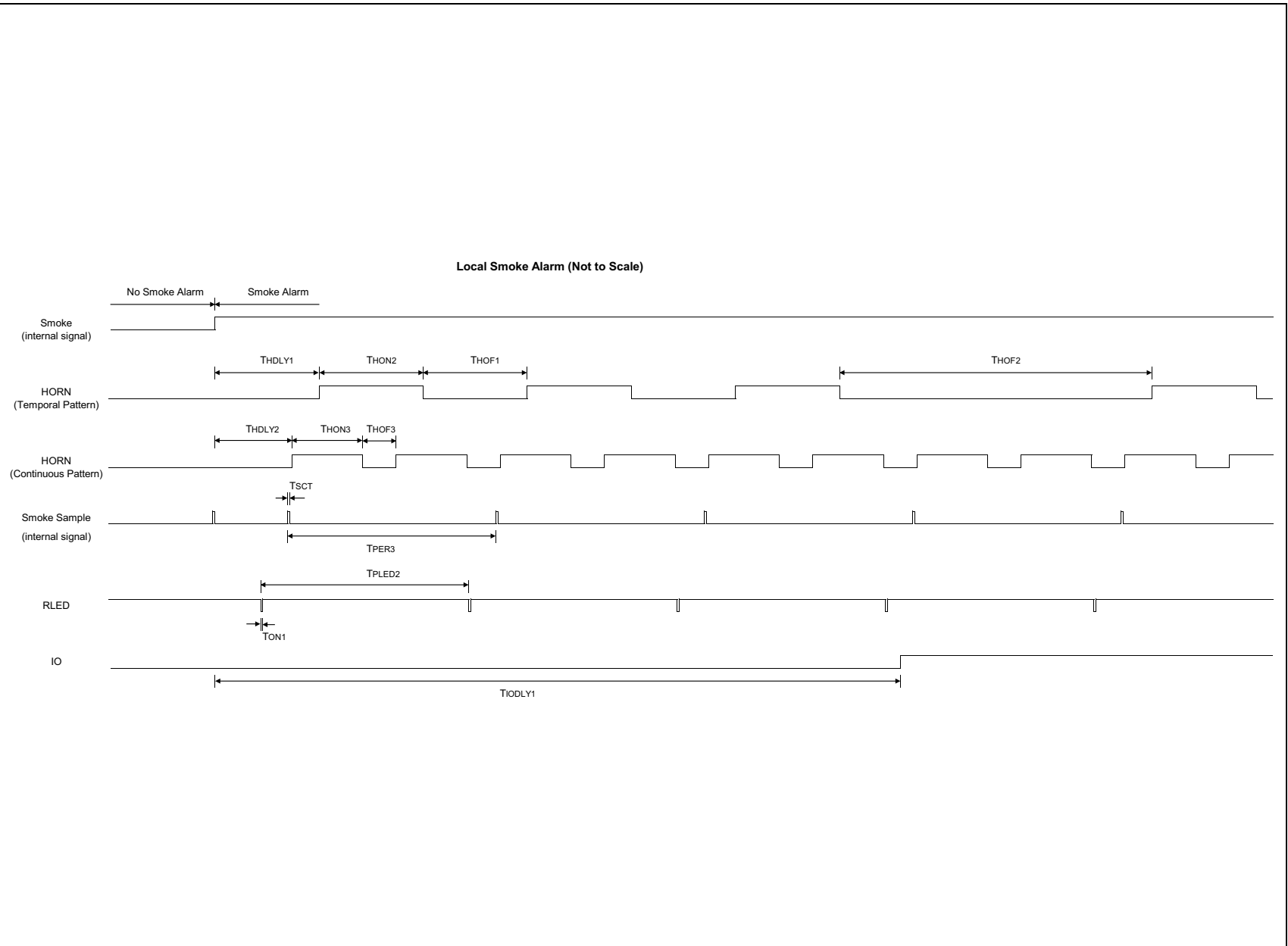

FIGURE 5-4: Timing Diagram – Local Smoke Alarm.

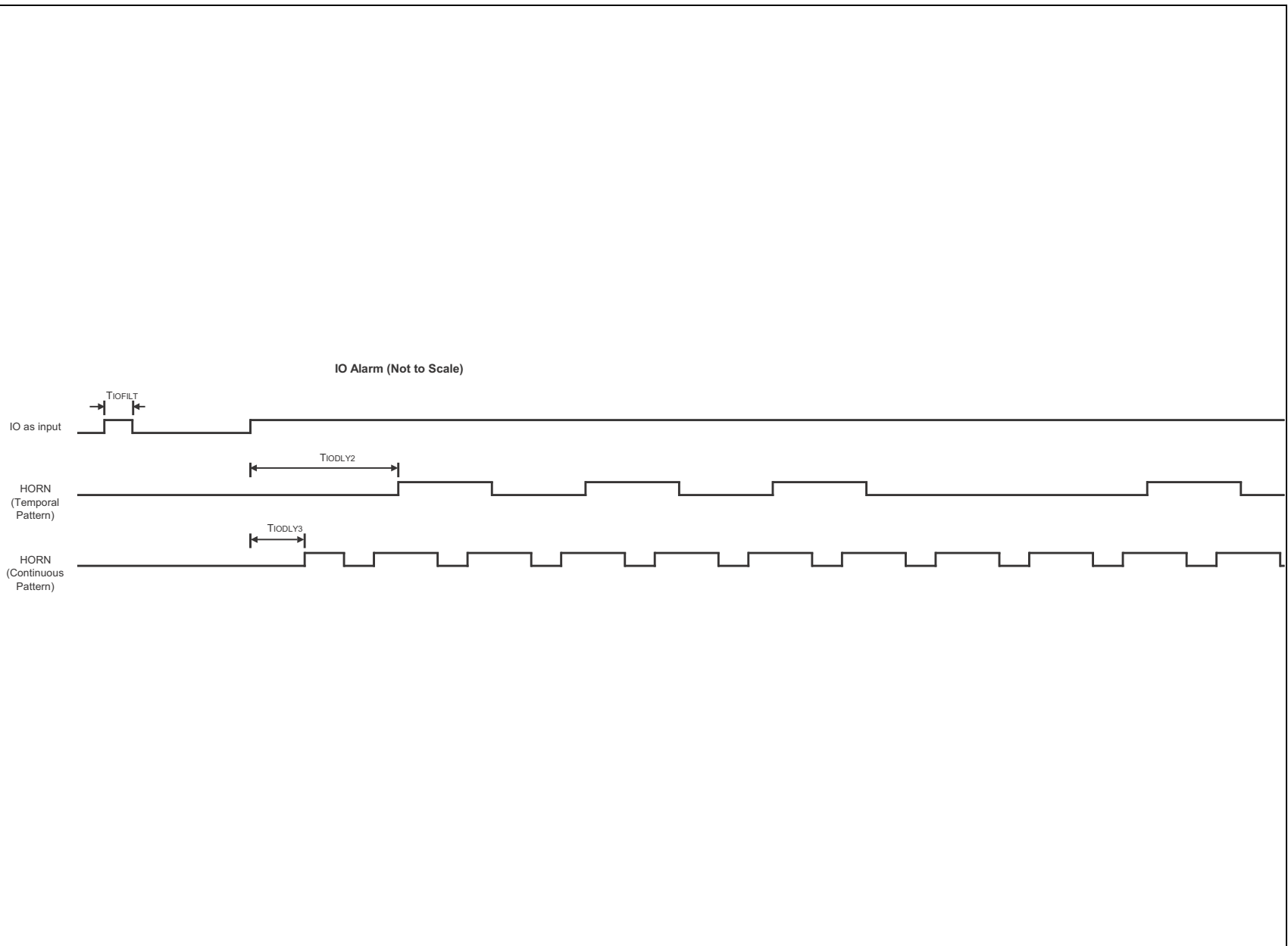
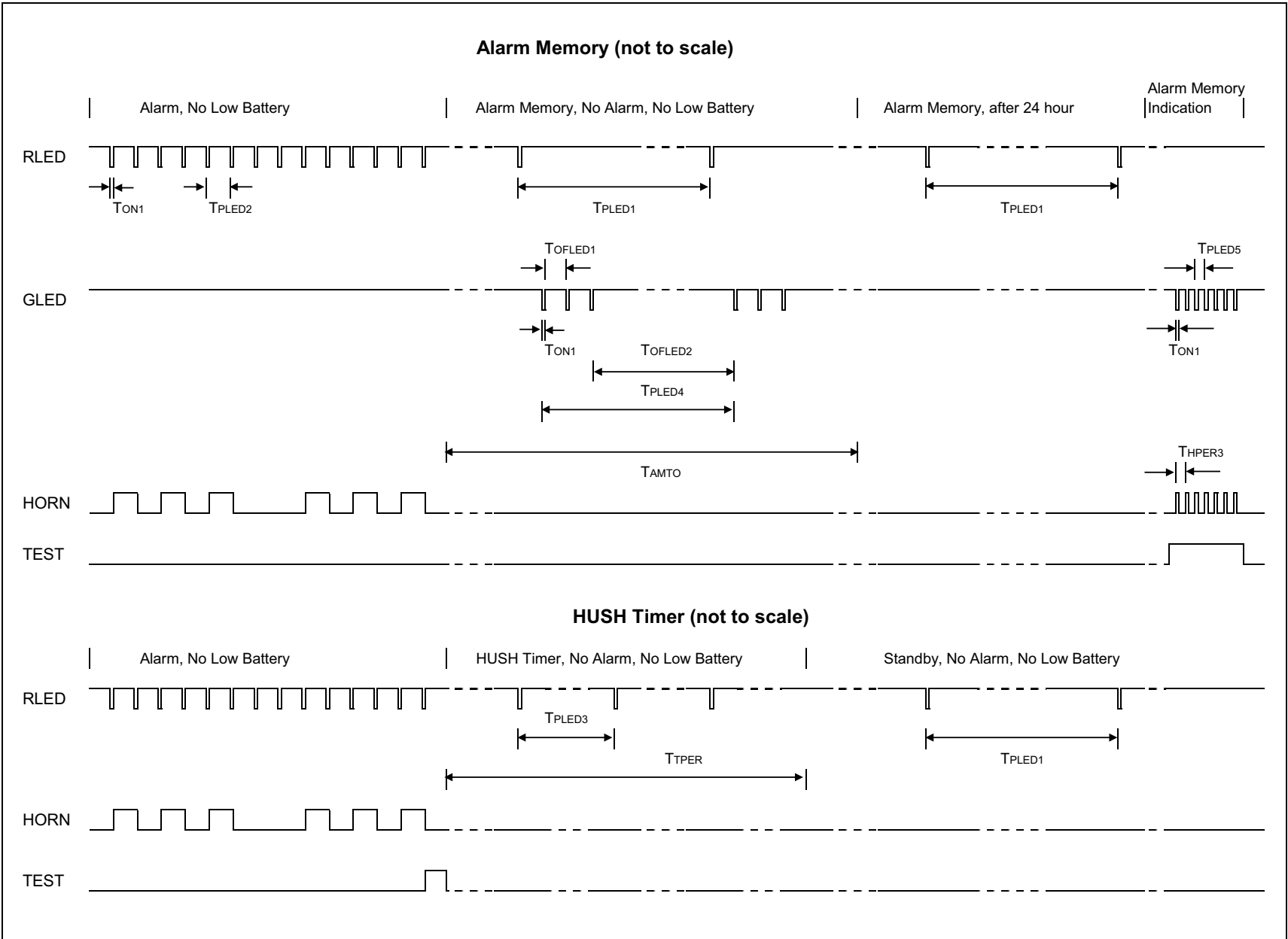

FIGURE 5-5: Timing Diagram – IO Smoke Alarm.

FIGURE 5-6: Timing Diagram – Alarm Memory and HUSH Timer.



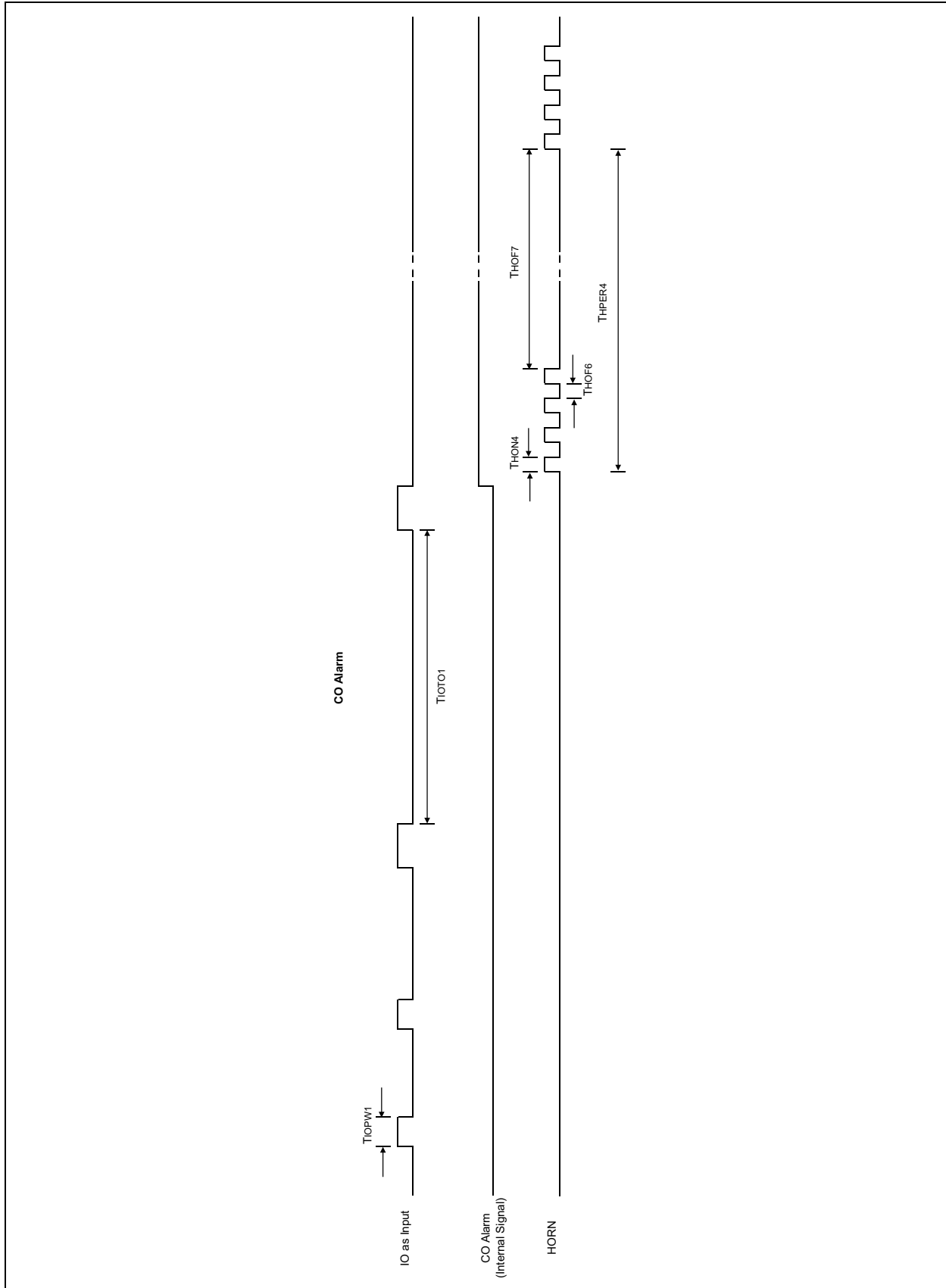

FIGURE 5-7: Timing Diagram – CO Alarm.

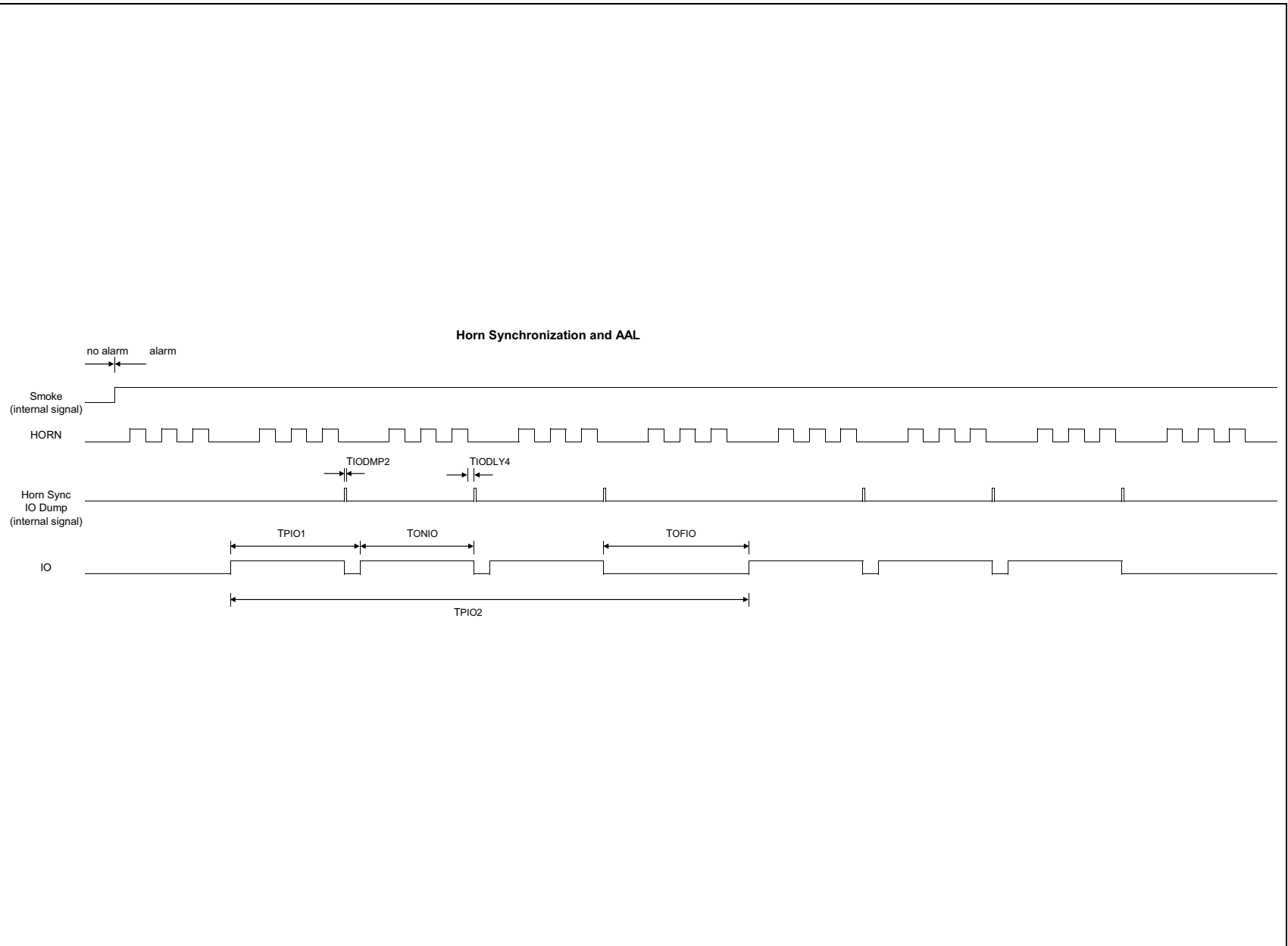

FIGURE 5-8: Timing Diagram – Horn Synchronization and AAL.

RE46C180

NOTES:

6.0 PACKAGING INFORMATION

6.1 Package Marking Information

16-Lead PDIP (300 mil)

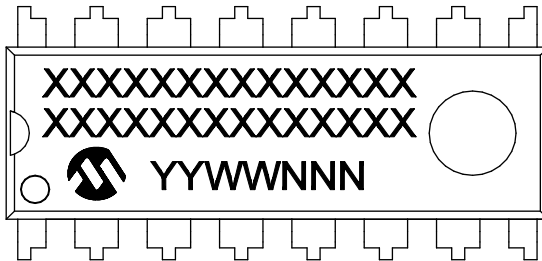

Example

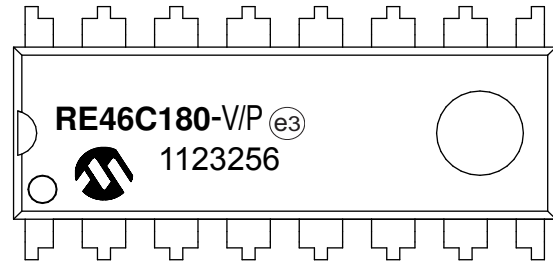

16-Lead Narrow SOIC (3.90 mm)

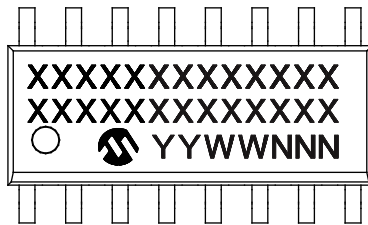

Example

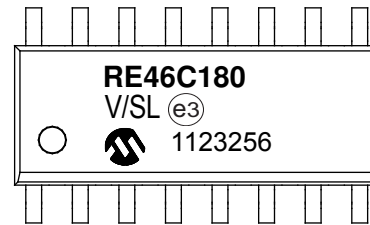

Legend:XX...XCustomer-specific information

YYear code (last digit of calendar year)

YYYear code (last 2 digits of calendar year)

WWWeek code (week of January 1 is week '01')

NNNAlphanumeric traceability code

Pb-free JE(e3):C designator for Matte Tin (Sn)

*This package is Pb-free. The Pb-free JEDEC designator () can be found on the outer packaging for this package.

(e3)

Note:In the event the full Microchip part number cannot be marked on one line, it will be carried over to the next line, thus limiting the number of available characters for customer-specific information.

RE46C180

16-Lead Plastic Dual In-Line (P) – 300 mil Body [PDIP]

Note: For the most current package drawings, please see the Microchip Packaging Specification located at <http://www.microchip.com/packaging>

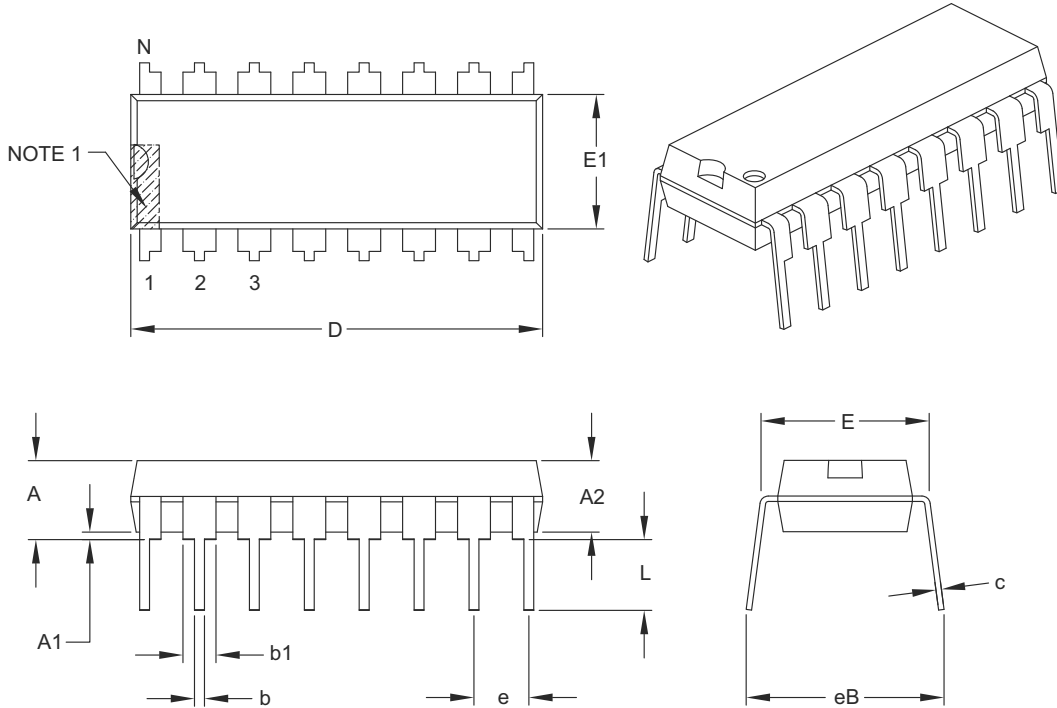

		Units	INCHES		
Dimension Limits			MIN	NOM	MAX
Number of Pins	N		16		
Pitch	e		.100 BSC		
Top to Seating Plane	A	–	–	.210	
Molded Package Thickness	A2	.115	.130	.195	
Base to Seating Plane	A1	.015	–	–	
Shoulder to Shoulder Width	E	.290	.310	.325	
Molded Package Width	E1	.240	.250	.280	
Overall Length	D	.735	.755	.775	
Tip to Seating Plane	L	.115	.130	.150	
Lead Thickness	c	.008	.010	.015	
Upper Lead Width	b1	.045	.060	.070	
Lower Lead Width	b	.014	.018	.022	
Overall Row Spacing §	eB	–	–	.430	

Notes:

- Pin 1 visual index feature may vary, but must be located within the hatched area.
- § Significant Characteristic.
- Dimensions D and E1 do not include mold flash or protrusions. Mold flash or protrusions shall not exceed .010" per side.
- Dimensioning and tolerancing per ASME Y14.5M.

BSC: Basic Dimension. Theoretically exact value shown without tolerances.

Microchip Technology Drawing C04-017B

16-Lead Plastic Small Outline (SL) - Narrow, 3.90 mm Body [SOIC]

Note: For the most current package drawings, please see the Microchip Packaging Specification located at <http://www.microchip.com/packaging>

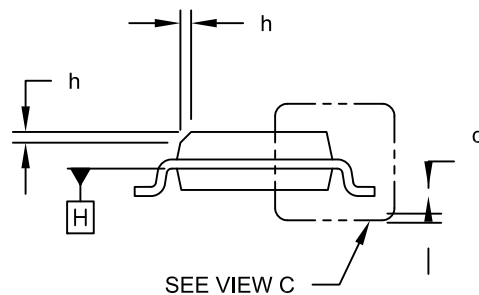
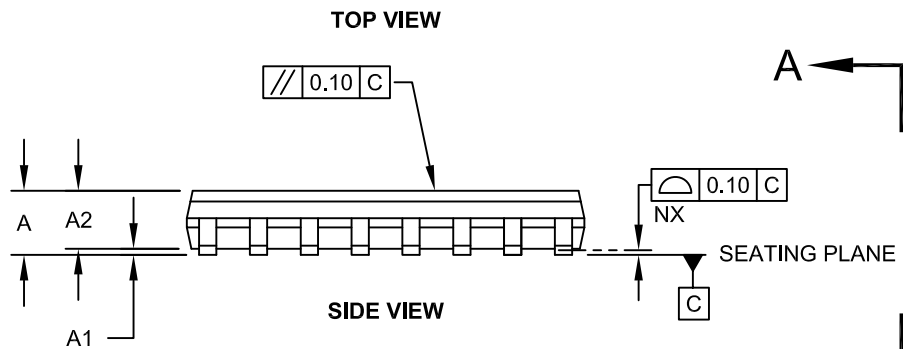
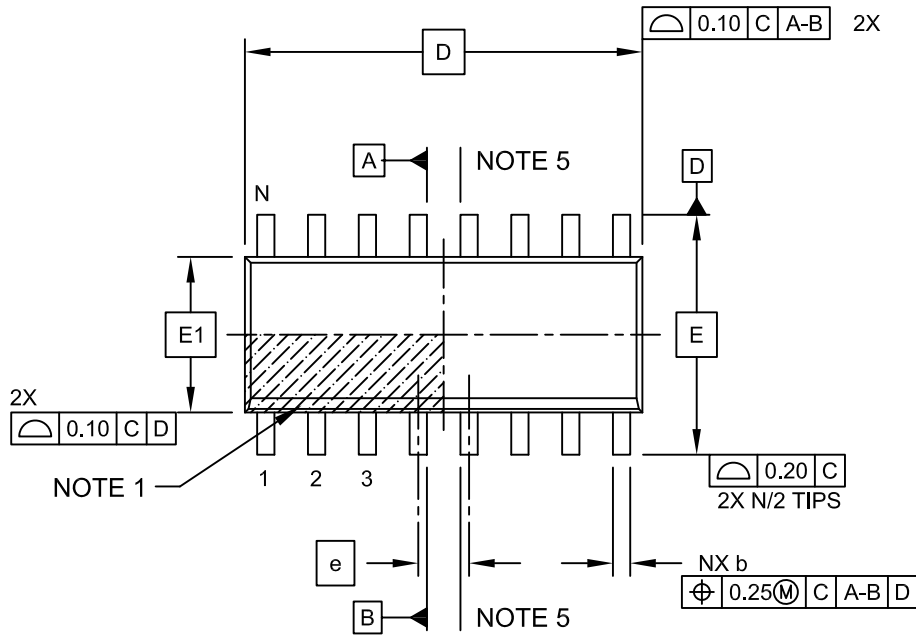

Microchip Technology Drawing No. C04-108C Sheet 1 of 2

RE46C180

16-Lead Plastic Small Outline (SL) - Narrow, 3.90 mm Body [SOIC]

Note: For the most current package drawings, please see the Microchip Packaging Specification located at <http://www.microchip.com/packaging>

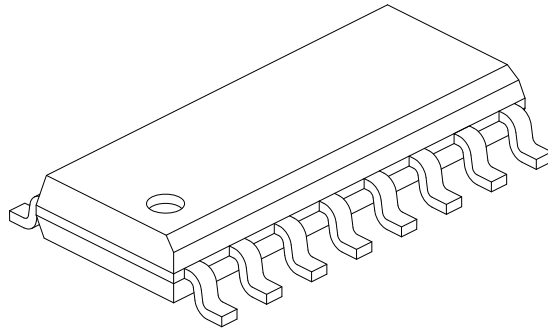
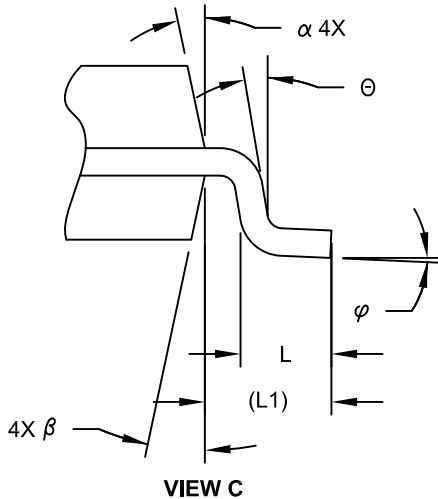

		MILLIMETERS		
Units		MIN	NOM	MAX
Dimension Limits				
Number of Pins	N	16		
Pitch	e	1.27 BSC		
Overall Height	A	-	-	1.75
Molded Package Thickness	A2	1.25	-	-
Standoff §	A1	0.10	-	0.25
Overall Width	E	6.00 BSC		
Molded Package Width	E1	3.90 BSC		
Overall Length	D	9.90 BSC		
Chamfer (Optional)	h	0.25	-	0.50
Foot Length	L	0.40	-	1.27
Footprint	L1	1.04 REF		
Lead Angle	θ	0°	-	-
Foot Angle	φ	0°	-	8°
Lead Thickness	c	0.10	-	0.25
Lead Width	b	0.31	-	0.51
Mold Draft Angle Top	α	5°	-	15°
Mold Draft Angle Bottom	β	5°	-	15°

Notes:

- Pin 1 visual index feature may vary, but must be located within the hatched area.
- § Significant Characteristic
- Dimension D does not include mold flash, protrusions or gate burrs, which shall not exceed 0.15 mm per end. Dimension E1 does not include interlead flash or protrusion, which shall not exceed 0.25 mm per side.
- Dimensioning and tolerancing per ASME Y14.5M
 BSC: Basic Dimension. Theoretically exact value shown without tolerances.
 REF: Reference Dimension, usually without tolerance, for information purposes only.
- Datums A & B to be determined at Datum H.

Microchip Technology Drawing No. C04-108C Sheet 2 of 2

16-Lead Plastic Small Outline (SL) - Narrow, 3.90 mm Body [SOIC]

Note: For the most current package drawings, please see the Microchip Packaging Specification located at <http://www.microchip.com/packaging>

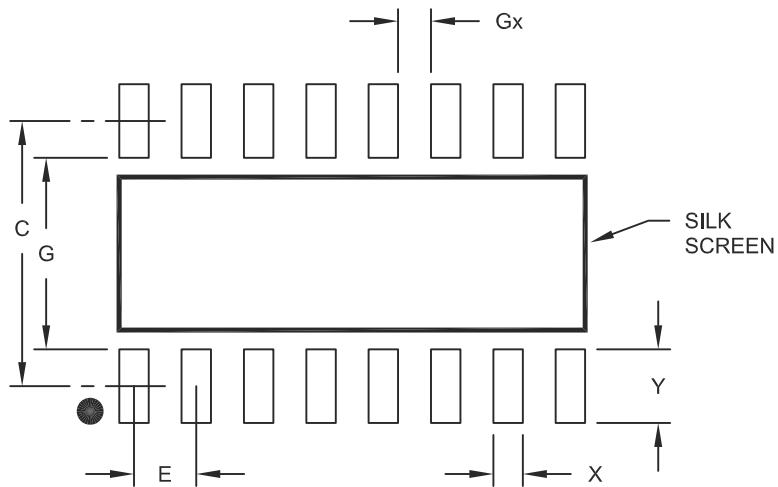

RECOMMENDED LAND PATTERN

		Units	MILLIMETERS		
		Dimension Limits	MIN	NOM	MAX
Contact Pitch	E	1.27 BSC			
Contact Pad Spacing	C	5.40			
Contact Pad Width	X				0.60
Contact Pad Length	Y				1.50
Distance Between Pads	Gx	0.67			
Distance Between Pads	G	3.90			

Notes:

1. Dimensioning and tolerancing per ASME Y14.5M

BSC: Basic Dimension. Theoretically exact value shown without tolerances.

Microchip Technology Drawing No. C04-2108A

RE46C180

NOTES:

APPENDIX A: REVISION HISTORY

Revision A (August 2011)

Original Release of this Document.

RE46C180

NOTES:

PRODUCT IDENTIFICATION SYSTEM

To order or obtain information, e.g., on pricing or delivery, refer to the factory or the listed sales office.

<u>PART NO.</u>	<u>X</u>	<u>XX</u>
Device	Package	Number of Pins
Device	DSTEMP:	CMOS Programmable Ionization Smoke Detector ASIC
	DSTEMPT:	CMOS Programmable Ionization Smoke Detector ASIC (Tape and Reel, SOIC only)
Package	E	= Plastic Dual In-Line, 150 mil. Body, 16-Lead (PDIP)
	S	= Small Plastic Outline - Narrow, 3.90 mm Body, 16-Lead (SOIC)

Examples:

- a) RE46C180E16F: 16LD PDIP Package
- b) RE46C180S16F: 16LD SOIC Package
- c) RE46C180S16TF: 16LD SOIC Package, Tape and Reel

RE46C180

NOTES:

Note the following details of the code protection feature on Microchip devices:

- Microchip products meet the specification contained in their particular Microchip Data Sheet.
- Microchip believes that its family of products is one of the most secure families of its kind on the market today, when used in the intended manner and under normal conditions.
- There are dishonest and possibly illegal methods used to breach the code protection feature. All of these methods, to our knowledge, require using the Microchip products in a manner outside the operating specifications contained in Microchip's Data Sheets. Most likely, the person doing so is engaged in theft of intellectual property.
- Microchip is willing to work with the customer who is concerned about the integrity of their code.
- Neither Microchip nor any other semiconductor manufacturer can guarantee the security of their code. Code protection does not mean that we are guaranteeing the product as “unbreakable.”

Code protection is constantly evolving. We at Microchip are committed to continuously improving the code protection features of our products. Attempts to break Microchip's code protection feature may be a violation of the Digital Millennium Copyright Act. If such acts allow unauthorized access to your software or other copyrighted work, you may have a right to sue for relief under that Act.

Information contained in this publication regarding device applications and the like is provided only for your convenience and may be superseded by updates. It is your responsibility to ensure that your application meets with your specifications. MICROCHIP MAKES NO REPRESENTATIONS OR WARRANTIES OF ANY KIND WHETHER EXPRESS OR IMPLIED, WRITTEN OR ORAL, STATUTORY OR OTHERWISE, RELATED TO THE INFORMATION, INCLUDING BUT NOT LIMITED TO ITS CONDITION, QUALITY, PERFORMANCE, MERCHANTABILITY OR FITNESS FOR PURPOSE. Microchip disclaims all liability arising from this information and its use. Use of Microchip devices in life support and/or safety applications is entirely at the buyer's risk, and the buyer agrees to defend, indemnify and hold harmless Microchip from any and all damages, claims, suits, or expenses resulting from such use. No licenses are conveyed, implicitly or otherwise, under any Microchip intellectual property rights.

Trademarks

The Microchip name and logo, the Microchip logo, dsPIC, KEELOQ, KEELOQ logo, MPLAB, PIC, PICmicro, PICSTART, PIC³² logo, rPIC and UNI/O are registered trademarks of Microchip Technology Incorporated in the U.S.A. and other countries.

FilterLab, Hampshire, HI-TECH C, Linear Active Thermistor, MXDEV, MXLAB, SEEVAL and The Embedded Control Solutions Company are registered trademarks of Microchip Technology Incorporated in the U.S.A.

Analog-for-the-Digital Age, Application Maestro, chipKIT, chipKIT logo, CodeGuard, dsPICDEM, dsPICDEM.net, dsPICworks, dsSPEAK, ECAN, ECONOMONITOR, FanSense, HI-TIDE, In-Circuit Serial Programming, ICSP, Mindi, MiWi, MPASM, MPLAB Certified logo, MPLIB, MPLINK, mTouch, Omniscient Code Generation, PICC, PICC-18, PICDEM, PICDEM.net, PICKit, PICtail, REAL ICE, rLAB, Select Mode, Total Endurance, TSHARC, UniWinDriver, WiperLock and ZENA are trademarks of Microchip Technology Incorporated in the U.S.A. and other countries.

SQTP is a service mark of Microchip Technology Incorporated in the U.S.A.

All other trademarks mentioned herein are property of their respective companies.

© 2011, Microchip Technology Incorporated, Printed in the U.S.A., All Rights Reserved.

 Printed on recycled paper.

ISBN: 978-1-61341-346-3

Microchip received ISO/TS-16949:2009 certification for its worldwide headquarters, design and wafer fabrication facilities in Chandler and Tempe, Arizona; Gresham, Oregon and design centers in California and India. The Company's quality system processes and procedures are for its PIC[®] MCUs and dsPIC[®] DSCs, KEELOQ[®] code hopping devices, Serial EEPROMs, microperipherals, nonvolatile memory and analog products. In addition, Microchip's quality system for the design and manufacture of development systems is ISO 9001:2000 certified.

QUALITY MANAGEMENT SYSTEM
CERTIFIED BY DNV
== ISO/TS 16949:2009 ==



MICROCHIP

Worldwide Sales and Service

AMERICAS

Corporate Office
2355 West Chandler Blvd.
Chandler, AZ 85224-6199
Tel: 480-792-7200
Fax: 480-792-7277
Technical Support:
<http://www.microchip.com/support>

Web Address:
www.microchip.com

Atlanta
Duluth, GA
Tel: 678-957-9614
Fax: 678-957-1455

Boston
Westborough, MA
Tel: 774-760-0087
Fax: 774-760-0088

Chicago
Itasca, IL
Tel: 630-285-0071
Fax: 630-285-0075

Cleveland
Independence, OH
Tel: 216-447-0464
Fax: 216-447-0643

Dallas
Addison, TX
Tel: 972-818-7423
Fax: 972-818-2924

Detroit
Farmington Hills, MI
Tel: 248-538-2250
Fax: 248-538-2260

Indianapolis
Noblesville, IN
Tel: 317-773-8323
Fax: 317-773-5453

Los Angeles
Mission Viejo, CA
Tel: 949-462-9523
Fax: 949-462-9608

Santa Clara
Santa Clara, CA
Tel: 408-961-6444
Fax: 408-961-6445

Toronto
Mississauga, Ontario,
Canada
Tel: 905-673-0699
Fax: 905-673-6509

ASIA/PACIFIC

Asia Pacific Office
Suites 3707-14, 37th Floor
Tower 6, The Gateway
Harbour City, Kowloon
Hong Kong
Tel: 852-2401-1200
Fax: 852-2401-3431

Australia - Sydney
Tel: 61-2-9868-6733
Fax: 61-2-9868-6755

China - Beijing
Tel: 86-10-8569-7000
Fax: 86-10-8528-2104

China - Chengdu
Tel: 86-28-8665-5511
Fax: 86-28-8665-7889

China - Chongqing
Tel: 86-23-8980-9588
Fax: 86-23-8980-9500

China - Hangzhou
Tel: 86-571-2819-3187
Fax: 86-571-2819-3189

China - Hong Kong SAR
Tel: 852-2401-1200
Fax: 852-2401-3431

China - Nanjing
Tel: 86-25-8473-2460
Fax: 86-25-8473-2470

China - Qingdao
Tel: 86-532-8502-7355
Fax: 86-532-8502-7205

China - Shanghai
Tel: 86-21-5407-5533
Fax: 86-21-5407-5066

China - Shenyang
Tel: 86-24-2334-2829
Fax: 86-24-2334-2393

China - Shenzhen
Tel: 86-755-8203-2660
Fax: 86-755-8203-1760

China - Wuhan
Tel: 86-27-5980-5300
Fax: 86-27-5980-5118

China - Xian
Tel: 86-29-8833-7252
Fax: 86-29-8833-7256

China - Xiamen
Tel: 86-592-2388138
Fax: 86-592-2388130

China - Zhuhai
Tel: 86-756-3210040
Fax: 86-756-3210049

ASIA/PACIFIC

India - Bangalore
Tel: 91-80-3090-4444
Fax: 91-80-3090-4123

India - New Delhi
Tel: 91-11-4160-8631
Fax: 91-11-4160-8632

India - Pune
Tel: 91-20-2566-1512
Fax: 91-20-2566-1513

Japan - Yokohama
Tel: 81-45-471- 6166
Fax: 81-45-471-6122

Korea - Daegu
Tel: 82-53-744-4301
Fax: 82-53-744-4302

Korea - Seoul
Tel: 82-2-554-7200
Fax: 82-2-558-5932 or
82-2-558-5934

Malaysia - Kuala Lumpur
Tel: 60-3-6201-9857
Fax: 60-3-6201-9859

Malaysia - Penang
Tel: 60-4-227-8870
Fax: 60-4-227-4068

Philippines - Manila
Tel: 63-2-634-9065
Fax: 63-2-634-9069

Singapore
Tel: 65-6334-8870
Fax: 65-6334-8850

Taiwan - Hsin Chu
Tel: 886-3-5778-366
Fax: 886-3-5770-955

Taiwan - Kaohsiung
Tel: 886-7-536-4818
Fax: 886-7-330-9305

Taiwan - Taipei
Tel: 886-2-2500-6610
Fax: 886-2-2508-0102

Thailand - Bangkok
Tel: 66-2-694-1351
Fax: 66-2-694-1350

EUROPE

Austria - Wels
Tel: 43-7242-2244-39
Fax: 43-7242-2244-393

Denmark - Copenhagen
Tel: 45-4450-2828
Fax: 45-4485-2829

France - Paris
Tel: 33-1-69-53-63-20
Fax: 33-1-69-30-90-79

Germany - Munich
Tel: 49-89-627-144-0
Fax: 49-89-627-144-44

Italy - Milan
Tel: 39-0331-742611
Fax: 39-0331-466781

Netherlands - Drunen
Tel: 31-416-690399
Fax: 31-416-690340

Spain - Madrid
Tel: 34-91-708-08-90
Fax: 34-91-708-08-91

UK - Wokingham
Tel: 44-118-921-5869
Fax: 44-118-921-5820

08/02/11