



# ACE729E

## 3A, 18V High Efficiency Synchronous Step-Down Converter

### Description

The ACE729E is a wide input range, high-efficiency, DC-to-DC step-down switching regulator, capable of delivering up to 3A of output current. Current mode PWM control allows the use of small external components, such as ceramic input and output caps, as well as small inductors, while still providing low output ripples. On top of the integrated internal synchronous rectifier that eliminates external Schottky diode, ACE729E also employs a proprietary control scheme that switches the device into a power save mode during light load, thereby extending the range of high efficiency operation. Therefore, ACE729E is a much superior solution in comparison to other competitions in terms of efficiency and cost. Overall, ACE729E is a highly efficient and robust solution for DC-DC step-down applications that requires wide input ranges.

ACE729E is available ESOP8 Packages..

### Features

- Wide Input Operating Range from 4.5V to 18V
- High Efficiency: Up to 95% at Light Load
- Capable of Delivering 3A.
- No External Schottky Diode Needed
- Inductor Short Circuit Protection
- Current Mode control
- 0.923V Reference for Low Output voltages
- Logic Control Shutdown
- Thermal shutdown and UVLO
- Available in ESOP8 Package

### Application

- LCD TVs
- Notebook computers
- FPGA power supplies
- LED drivers

### Absolute Maximum Ratings

Parameter	Value
IN Voltage	-0.3V~20V
SW, EN Voltage	-0.3V~VIN+0.3V
BST Voltage	-0.3V~SW+6V
FB Voltage	-0.3V~6V
SW to ground current	Internally limited
Operating Temperature Range	- 40°C~ 85°C
Storage Temperature Range	.-55°C~ 150°C

(Note: Exceeding these limits may damage the device. Exposure to absolute maximum rating conditions for long periods may affect device reliability.)



# ACE729E

## 3A, 18V High Efficiency Synchronous Step-Down Converter

### Packaging Type

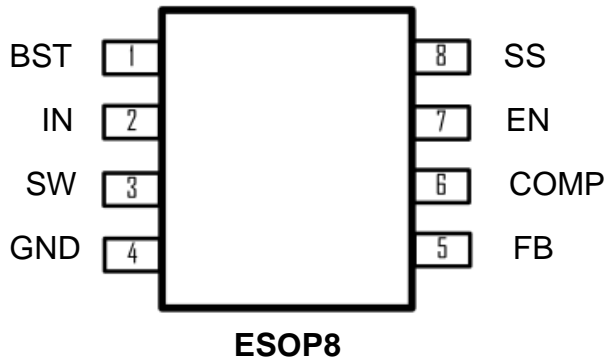

ESOP-8	Description	Function
1	BST	Bootstrap pin. Connect a 10nF capacitor from this pin to SW
2	IN	Supply Voltage. Bypass with a 22 $\mu$ F ceramic capacitor to GND
3	SW	Inductor Connection. Connect an inductor Between SW and the regulator output.
4	GND	Ground
5	FB	Feedback Input. Connect an external resistor divider from the output to FB and GND to set $V_{OUT}$
6	COMP	Regulator Compensation. Connect series RC network to GND.
7	EN	Enable pin for the IC. Drive this pin to high to enable the part, low to disable.
8	SS	Soft start pin. Connect a 0.1 $\mu$ F capacitor from this pin to GND

### Ordering information

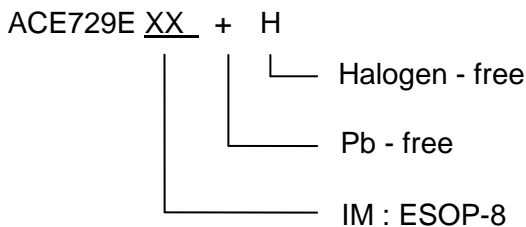



# ACE729E

## 3A, 18V High Efficiency Synchronous Step-Down Converter

### Typical Application

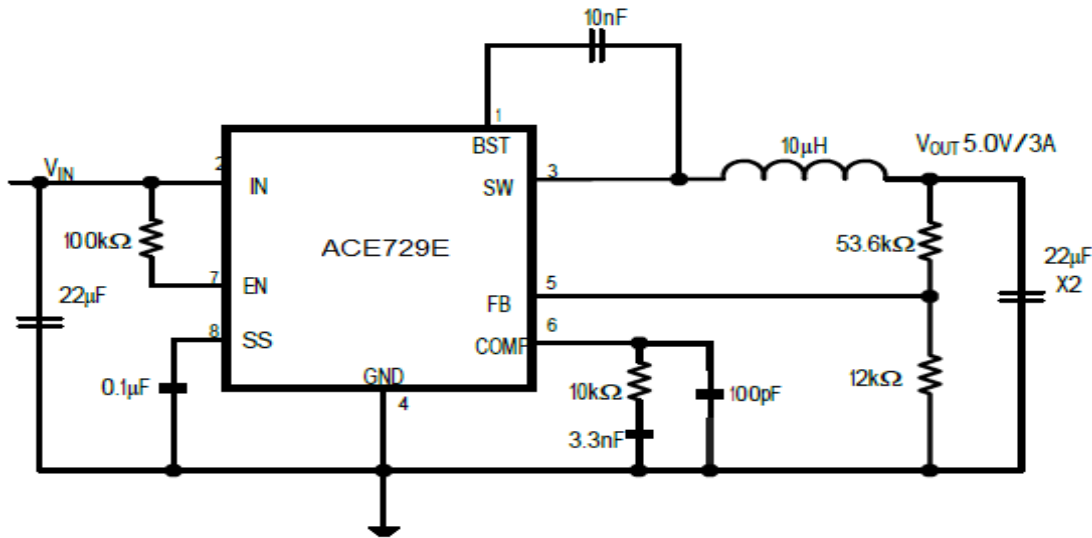

### 3A Wide Input Step Down Synchronous Converter

### Electrical Characteristics

( $V_{IN}=12V$ ,  $T_A=25^{\circ}C$ )

Parameter	Test Conditions	Min	Typ	Max	Unit
Input Voltage Range		4.2		18	V
Input UVLO	Rising, Hysteresis=140mV		3.55		V
Input Supply Current	$V_{FB}=1.0V$		1.6		mA
Input Shutdown Current			6		uA
FB Feedback Voltage		0.904	0.923	0.942	V
FB Input Current			0.01		uA
Error Amp Transconductance			800		uS
Switching Frequency			340		KHz
High side Switch On Resistance	$I_{SW}=200mA$		90		mΩ
Low side Switch On Resistance	$I_{SW}=200mA$		85		mΩ
High side Switch Current Limit			4		A
SW Leakage Current	$V_{IN}=12V, V_{SW}=0$ or $12V$ , $EN=GND$			10	uA
EN Input Current				1	uA
EN Input Low Voltage				0.5	uA
EN Input High Voltage		1.5			V
Thermal Shutdown	Hysteresis=40°C		150		°C



# ACE729E

## 3A, 18V High Efficiency Synchronous Step-Down Converter

### Typical performance characteristics

(Typical values are at  $T_A = 25^{\circ}\text{C}$  unless otherwise specified.)

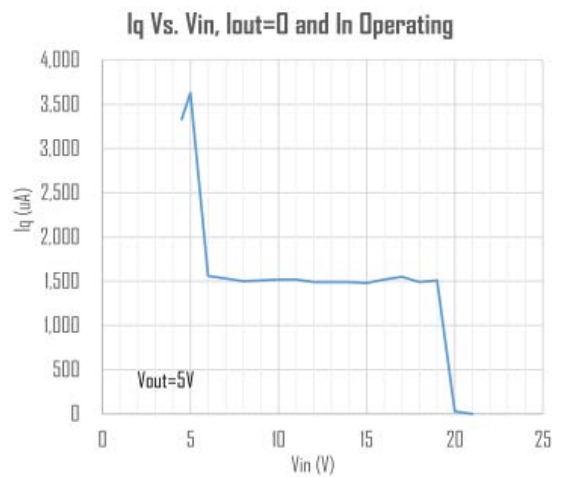
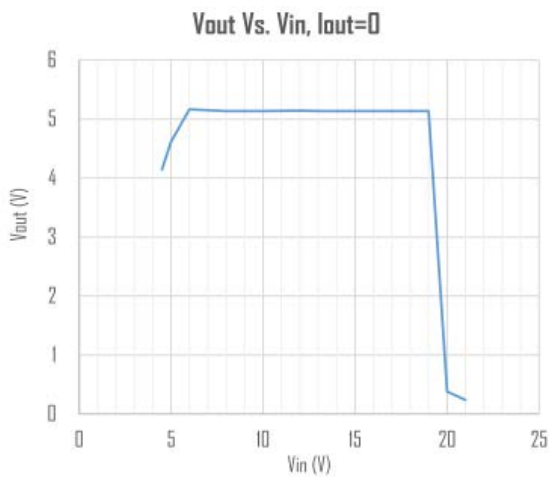
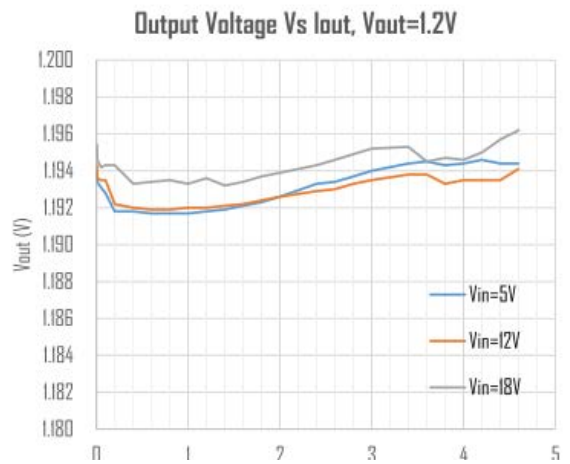
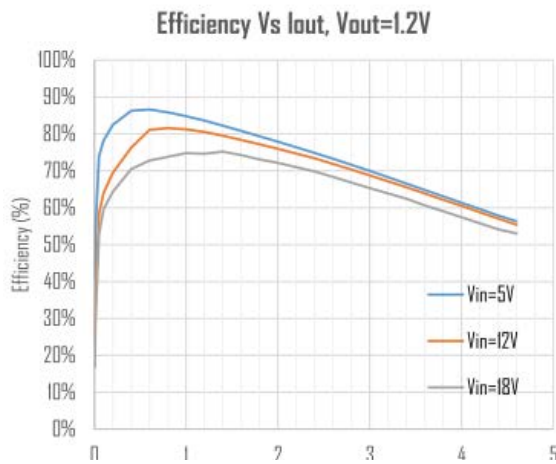
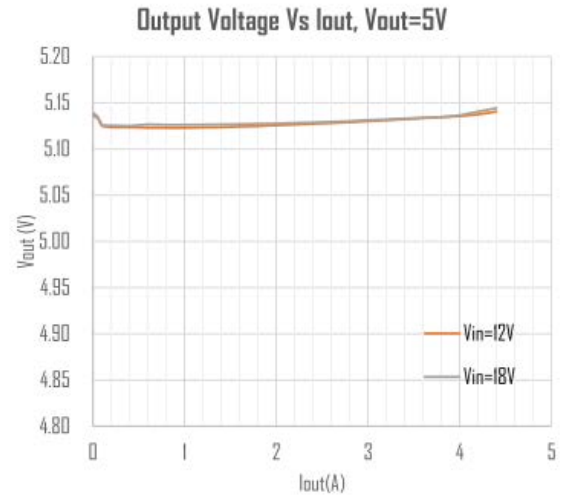
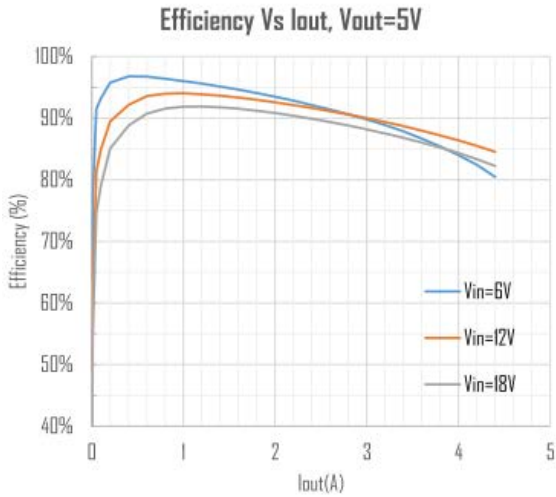



# ACE729E

## 3A, 18V High Efficiency Synchronous Step-Down Converter

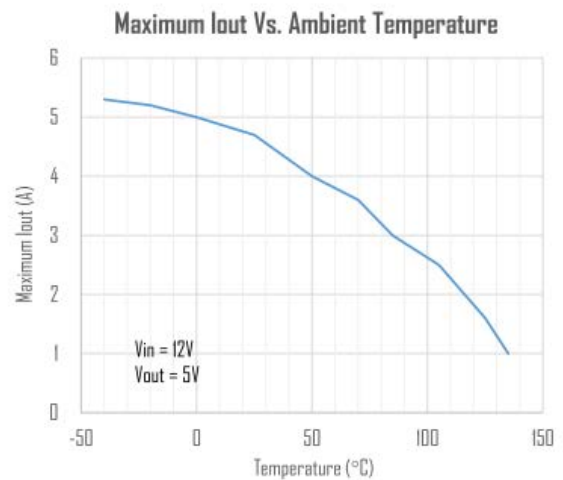
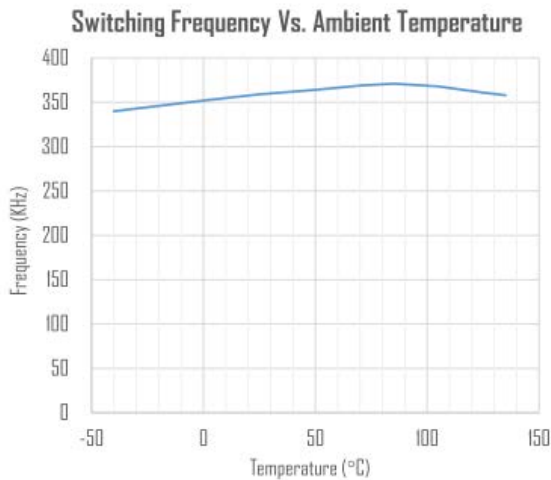

### Functional Descriptions

#### Loop Operation

The ACE729E is a wide input range, high-efficiency, DC-to-DC step-down switching regulator, capable of delivering up to 3A of output current, integrated with a 90/85mΩ synchronous MOSFET pair, eliminating the need for external diode. It uses a PWM current-mode control scheme. An error amplifier integrates error between the FB signal and the internal reference voltage. The output of the integrator is then compared to the sum of a current-sense signal and the slope compensation ramp. This operation generates a PWM signal that modulates the duty cycle of the power MOSFETs to achieve regulation for output voltage.

#### Current Limit

There is a cycle-by-cycle current limit on the high-side MOSFET of 4A(typ). When the current flowing out of SW exceeds this limit, the high-side MOSFET turns off and the synchronous rectifier turns on. Unlike the traditional method of current limiting by limiting the voltage at the compensation pin, which usually has large variation due to duty cycle variance, this type of peak current limiting scheme provides a relatively more accurate limit for output current, thereby lowering the requirements for system design.

#### Light Load Operation

Traditionally, a fixed constant frequency PWM DC-DC regulator always switches even when the output load is small. When energy is shuffling back and forth through the power MOSFETs, power is lost due to the finite RDSONs of the MOSFETs and parasitic capacitances. At light load, this loss is prominent and efficiency is therefore very low. ACE729E employs a proprietary control scheme that improves efficiency in this situation by enabling the device into a power save mode during light load, thereby extending the range of high efficiency operation.



# ACE729E

## 3A, 18V High Efficiency Synchronous Step-Down Converter

### APPLICATION INFORMATION

#### Components Selection

$V_{OUT}(V)$	1.2V	1.8V	2.5V	3.3V	5V	8V
$C_{OUT}(\mu F)$	22*2	22*2	22*2	22*2	22*2	22*2
$L(\mu H)$	3.3	4.7	6.8	10	15	22



# ACE729E

## 3A, 18V High Efficiency Synchronous Step-Down Converter

### Packing Information

#### ESOP-8

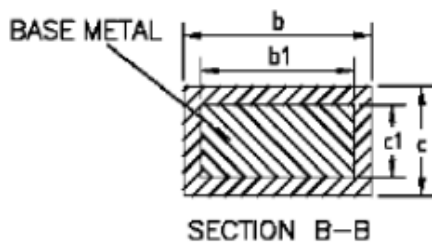
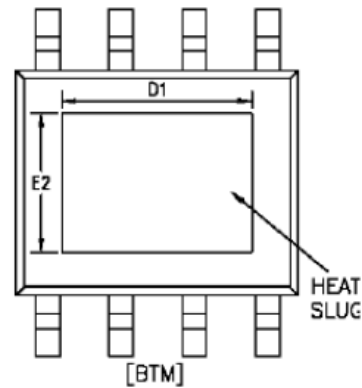
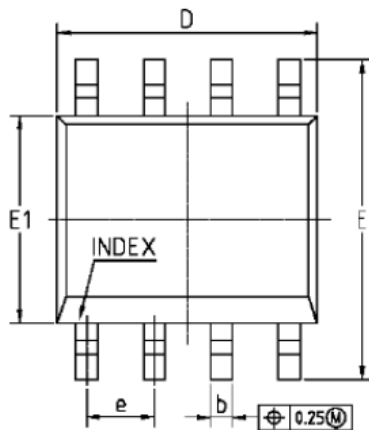
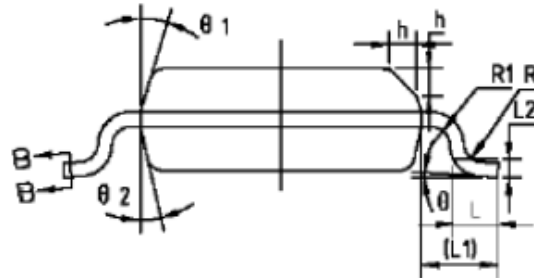
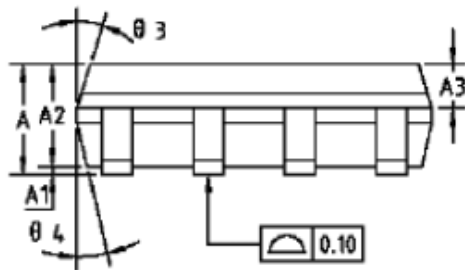

COMMON DIMENSIONS  
(UNITS OF MEASURE=MILLIMETER)

SYMBOL	MIN	NOM	MAX
A	1.35	1.55	1.75
A1	0	0.10	0.15
A2	1.25	1.40	1.65
A3	0.50	0.60	0.70
b	0.38	—	0.51
b1	0.37	0.42	0.47
c	0.17	—	0.25
c1	0.17	0.20	0.23
D	4.80	4.90	5.00
D1	3.10	3.30	3.50
E	5.80	6.00	6.20
E1	3.80	3.90	4.00
E2	2.20	2.40	2.60
e	1.27BSC		
L	0.45	0.60	0.80
L1	1.04REF		
L2	0.25BSC		
R	0.07	—	—
R1	0.07	—	—
h	0.30	0.40	0.50
theta	0°	—	8°
theta 1	15°	17°	19°
theta 2	11°	13°	15°
theta 3	15°	17°	19°
theta 4	11°	13°	15°

NOTES: ALL DIMENSIONS REFER TO JEDEC STANDARD MS-012 AA DO NOT INCLUDE MOLD FLASH OR PROTRUSIONS.



# ACE729E

## 3A, 18V High Efficiency Synchronous Step-Down Converter

### Notes

ACE does not assume any responsibility for use as critical components in life support devices or systems without the express written approval of the president and general counsel of ACE Electronics Co., LTD. As used herein:

1. Life support devices or systems are devices or systems which, (a) are intended for surgical implant into the body, or (b) support or sustain life, and whose failure to perform when properly used in accordance with instructions for use provided in the labeling, can be reasonably expected to result in a significant injury to the user.
2. A critical component is any component of a life support device or system whose failure to perform can be reasonably expected to cause the failure of the life support device or system, or to affect its safety or effectiveness.

ACE Technology Co., LTD.  
<http://www.ace-ele.com/>