



# **SUPERVERTER™**

## **150W and 240W DC-DC CONVERTERS MODELS: SV28-12-150/200**

**28VDC INPUT (18-36 VDC)**

**12 VDC @ 12.5A OUTPUT (-150)  
20A OUTPUT (-200)**

**Designed for Vehicle, Airborne  
and other rugged environment  
applications**



### **FEATURES**

- Industry Standard Half-brick Package
- High Efficiency
- Constant Frequency
- Clamp Over-Voltage Protection
- Remote Sense
- Trim Range: -40 to +10%
- Encapsulated
- High Power Density: up to 54 W/cu.in.
- Low Noise
- -40 to +100°C Operation
- 105°C Over Temperature Protection
- Choice of On/Off Logic
- UL/CSA/TUV & CE Compliant
- Threaded Mounting Holes

### **MODEL SELECTION**

Model Number	Input Voltage (Vdc)	Output Voltage (Vdc)	Output Current (A)
SV28-12-200-1	18-36	12	20
SV28-12-150-1	18-36	12	12.5

### **DESCRIPTION**

The SuperVerter series modules are high-density DC-DC converters designed for use in military and industrial applications such as on board vehicle and avionics electronic equipment. These are high power 28V input, 12V output, half brick modules that use insulated metal substrates, planar transformers, surface mount construction and thermally conductive potting to produce up to 240W of low noise, 12V output power.

# SUPERVERTER™ DC-DC Converters

## SV28-12-150/200

### ABSOLUTE MAXIMUM RATINGS

Exceeding absolute maximum ratings may cause permanent damage or reduce reliability.

PARAMETER	MIN	MAX	UNITS	CONDITIONS
Input Voltage (+In to -In)		40	Vdc	Continuous
Transient Input Voltage (+In to -In)		50	Vdc	100 msec. max.
Input/ Case Isolation		1500	Vdc	
Output/ Case Isolation		500	Vdc	
Input/ Output Isolation		1500	Vdc	
Storage Temperature	-40	+110	°C	
Operating Temperature	-40	+100	°C	Baseplate
Soldering Temperature (Wave Solder)		260	°C	< 5 sec.
Soldering Temperature (Hand Solder)		390	°C	< 7 sec.

### ELECTRICAL SPECIFICATIONS

Electrical specifications apply over the entire range of input voltage, output current, and temperature unless indicated.

INPUT PARAMETERS	MIN	TYP	MAX	UNITS	CONDITIONS
Input Voltage	18	28	36	Vdc	
Maximum Input Current SV28-12-150 SV28-12-200			10.6 15.8	A	Full load (See input characteristic curve)
Inrush Transient			1	A <sup>2</sup> sec	
Input Reflected Ripple Current		5		mAp-p	5Hz to 20MHz, 12μH source impedance
Input Ripple Rejection		60		dB	@120 Hz

OUTPUT PARAMETERS	MIN	TYP	MAX	UNITS	CONDITIONS
Voltage Set Point	11.78	12.00	12.22	Vdc	28 V <sub>in</sub> , 25°C, full load
Load Regulation		0.05	0.2	%	0.3 A to full load
Line Regulation		0.01	0.1	%	Over V <sub>in</sub> range
Voltage Drift w/Temperature		50	150	mV	-40 to +100 °C
Total Regulation			1.5	%	
Ripple			50 200	mV rms mV p-p	5 Hz to 20 MHz, ripple may exceed spec below minimum load
Rated Output Current SV28-12-150 SV28-12-200	0.3 0.3		12.5 20	A A	At I <sub>out</sub> < I <sub>out</sub> (min), the output ripple may exceed the specification. All other aspects of the unit will function properly at no load.

# SUPERVERTER™ DC-DC Converters

## SV28-12-150/200

### ELECTRICAL SPECIFICATIONS (continued)

Current Limit Inception SV28-12-150 SV28-12-200		14.4 23.0	16.3 25.0	A A	$V_{out} = 90\% V_{out\ nominal}$
Short Circuit Current			170	% F.L.	$V_{out} = 250\ mV$
Switching Frequency		370		kHz	
Transient Response Peak Deviation (0.1A/ $\mu$ sec slew rate)		2		% $V_{out}$	Load change from 50% to 75% or 50% to 25% full load
Transient Response Settling Time (0.1 A/ $\mu$ sec slew rate)			300	$\mu$ sec	$V_{in} = 28\ V$ , $T_{case} = 25\ ^\circ C$ , $V_{out}$ within 1% $V_{out\ nominal}$
Efficiency SV28-12-150 SV28-12-200	84 84	86 86		% %	$V_{in} = 28\ V$ , full load, $T_{case} = 70\ ^\circ C$
External Load Capacitance	0		5,000	$\mu$ F	Electrolytic Capacitor

ISOLATION PARAMETERS	MIN	TYP	MAX	UNITS	CONDITIONS
Input-to-Output Capacitance		2000		pF	
Input-to-Output Resistance	10			M Ohms	

FEATURE PARAMETERS	MIN	TYP	MAX	UNITS	CONDITIONS
Trim Range	60		110	% $V_{out}$	
Remote Sense Compensation			1.2	Vdc	
Over Voltage Clamp (Non-Shutdown, Auto. Recovery)	13.2		16	Vdc	
Over Temperature Shut-down		+105		$^\circ C$	
Turn-On Time		20	35	msec	80% load, $V_{out}$ within 1% of steady state
Logic On/Off *					
Logic Low $V_{on/off}$	0		1.2	V	@ $I_{on/off} = 1\ mA$
$I_{on/off}$			1.0	mA	@ $V_{on/off} = 0\ V$
Logic High: $V_{on/off}$			15	V	@ $I_{on/off} = 1\ mA$
$I_{on/off}$			50	$\mu$ A	@ $V_{on/off} = 15\ V$

\* Negative logic on/off is standard, positive logic is optional (delete the "-1" suffix from model number for positive logic). With negative logic, logic low turns module on, logic high turns it off. The reverse is true for positive logic.

# SUPERVERTER™ DC-DC Converter

## SV28-12-150/200

### MECHANICAL SPECIFICATIONS

MECHANICAL PARAMETERS	MIN	TYP	MAX	UNITS	CONDITIONS
Weight		118 (4.2)		g (oz.)	
Size		0.5 x 2.4 x 2.28		Inches	See Outline Drawing
Thermal Resistance, Case-to-Ambient		6.6		°C/W	T <sub>case</sub> = 100 °C

### TRIM CIRCUIT CONFIGURATIONS

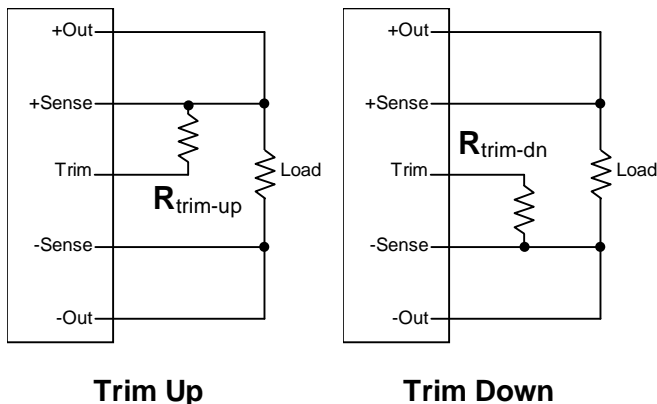

### OUTLINE DRAWING

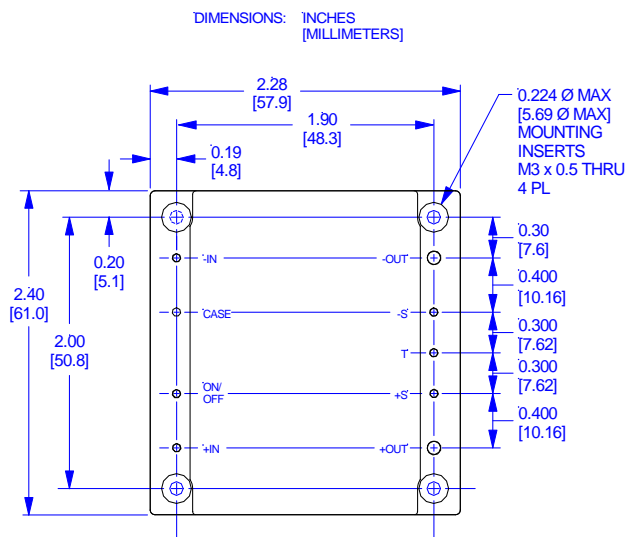

### TRIM RESISTOR CALCULATIONS

$$R_{\text{trim-up}} = \frac{12 \times (100 + \Delta\%)}{1.225 \times \Delta\%} - \frac{(100 + 2 \times \Delta\%)}{\Delta\%} \text{ kohms}$$

$$R_{\text{trim-down}} = \frac{100}{\Delta\%} - 2 \text{ kohms}$$

Δ% = Desired Output Voltage Change (Δ% > 0)

R<sub>trim-up</sub> = External Resistor Value to Increase V<sub>o</sub>

R<sub>trim-down</sub> = External Resistor Value to Decrease V<sub>o</sub>

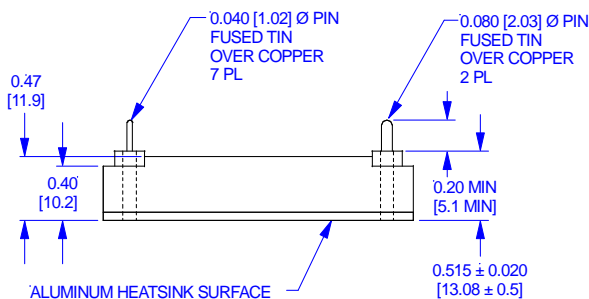

TOLERANCES:  $\begin{matrix} \text{x.xx in.} \pm 0.02 \text{ in.} \\ \text{[x.x mm.} \pm 0.5 \text{ mm.]} \end{matrix}$      $\begin{matrix} \text{x.xxx in.} \pm 0.010 \text{ in.} \\ \text{[x.xx mm.} \pm 0.25 \text{ mm.]} \end{matrix}$