

- Constant Current Operation Design to Eliminate LED Drivers
- UL8750
- Universal AC Input of 90-264VAC
- Built-In Active PFC Function ≥ 0.9 @ 100-230VAC
- Compliance to EN61000-3-2 Class C
- Adjustable OCP Level
- Auto Recovery Protections: Short Circuit/Overload/Over Voltage
- No Minimum Load Requirement
- Cooling by Free Air Convection
- Suitable for LED Lighting
- High Reliability, 150,000 Hours MTBF

Model Number	Output Voltage	Output Amps	Efficiency (typ)	OVP	Ripple & Noise	Current Adjust	Constant Current Region Vout Range
SINGLE OUTPUT							
OLP48-12	12 VDC	4 A	82%	14.4~17 VDC	2.0V pk-pk	2.8~4.0Amps	7.4~12Volts
OLP48-24	24 VDC	2 A	86%	28.8~34 VDC	3.0V pk-pk	1.4~2.0Amps	15~24Volts
OLP48-48	48 VDC	1 A	87%	57.6~68 VDC	4.8V pk-pk	0.7-1.0Amps	33~48Volts

All specifications are typical at nominal input, full load, and 25°C unless otherwise noted

48W Single Output Constant Current LED Power Supply

OLP48 series

INPUT SPECIFICATIONS

Input Voltage Range (Note 8)	90-264VAC
Frequency Range	47-63 Hz
Input Current (115/230 VAC)	0.8A/0.4A
Inrush Current (115/230VAC)	30/60A Cold Start, max.
Leakage Current (Safety Class II)	<0.25mA@240VAC, 50Hz
Power Factor	>0.9 at Full Load, 100-230VAC

OUTPUT SPECIFICATIONS

Voltage and Current (Note 3)	See Selection Chart
Line Regulation (Note 5 & 6)	±1%
Load Regulation (Note 5 & 7)	±2%
Ripple/Noise (Note 1 & 3)	See Selection Chart
Over Voltage Protection *	See Selection Chart Shut down Latch Mode, re-power
Over Current Protection *	Hiccup mode, auto recovery after fault condition is removed
Short Circuit *	Hiccup mode, auto recovery after fault condition is removed
Turn On Delay Time	<2S
Current Adjust Range (Note 2)	See Selection Chart
Constant Current Region (Note 2)	See Selection Chart
Over Shoot/Under Shoot	<10% nominal voltage, 100-240VAC

ENVIRONMENTAL SPECIFICATIONS

Oper. Temperature	-30°C to +80°C (See Derate Curve)
Relative Humidity	20~90% RH non cond
Storage Temperature	30°C to +85°C, 0~95% RH
MTBF	150KHrs min, MIL-HDBK-217F (25°C) Parts Count Method
Temp. Coefficient	±0.03%/°C (0~50°C)

PHYSICAL SPECIFICATIONS

Size (H x W x L)	1.34"x1.86"x4" (34 x 47 x 101.6 mm)
Weight	4.8 oz (136g)

* These are stress ratings. Exposure of the devices to any of these conditions may adversely affect long term reliability. Proper operation under conditions other than the standard operating conditions is neither warranted nor implied.

GENERAL SPECIFICATIONS

Safety	UL/cUL:	UL8750, UL60950-1 2nd ed./ C22.2 60950-1 2nd ed.
	UL-EU:	EN60950-1 2nd ed.
	CE:	EN60601-1-2
	CB:	IEC60950-1 2nd ed.
EMI Compliance		FCC Part 18 Class B & CISPR EN55015 Class B for Lighting
		Device; CISPR EN55022 Class B
Isolation (I/P-O/P) *		3KVAC (4242VDC), 60S
Isolation Resistance, (I/P-O/P)		>100MΩ / 500VDC @ 1S 25°C
Efficiency (Note 4)		See Selection Chart
EMS	Harmonics	Compliance to EN61000-3-2 Class C
	ESD	61000-4-2, Contact 6KV, Air 8KV,
	RS	FR: 80MHz-2.5GHz 61000-4-3, Field Strength: 3V/M
	EFT	61000-4-4, 2kV on AC power Line
	Surge	61000-4-5, 1kV (L-N)
	CS	61000-4-6, 3V (EFM)
	DIPS	61000-4-11, 95% 250Cy, 70% 25Cy, 40% 5Cy, 5% 0.5Cy, Applicable for 240VAC
	Vibration *	2G 's peak, 10~500Hz, 3 AXES, Period 30 Min each along X,Y,Z axes
Drop Test *		70 cm no damage / carton package

NOTES

- Ripple & noise are measured at 20MHz of bandwidth by using a 12" twisted pair-wire terminated with a 0.1uf & 47uf parallel capacitor
- Constant current adjustable from 70-100% by trim pot
- All measurements should be made directly at the output terminals. Operation outside the specified constant current range may cause hic-up resulting in LED blinking or LED dimming
- Efficiency is measured at 100-240VAC input incorporated with a constant load.
- Load/Line regulation measures constant current accuracy
- 100-240VAC Input, CC set @ 90% Load
- Set CC between 65%-95% load
- Derating may be needed at low input voltage. Please check the derating curve for more details.

OUTPUT POWER DERATING

Temperature Derating

- a. -30°C~60°C: No derating required
- b. Derate linearly 2%/°C from 60°C to 80°C at 100-265VAC input
See Curve Below

Input Voltage Derating

- c. Input voltage vs. operating temperature: Derate maximum output by 5 watts for input voltage 90-100VAC when operating temperature is >50°C

Derating Curve

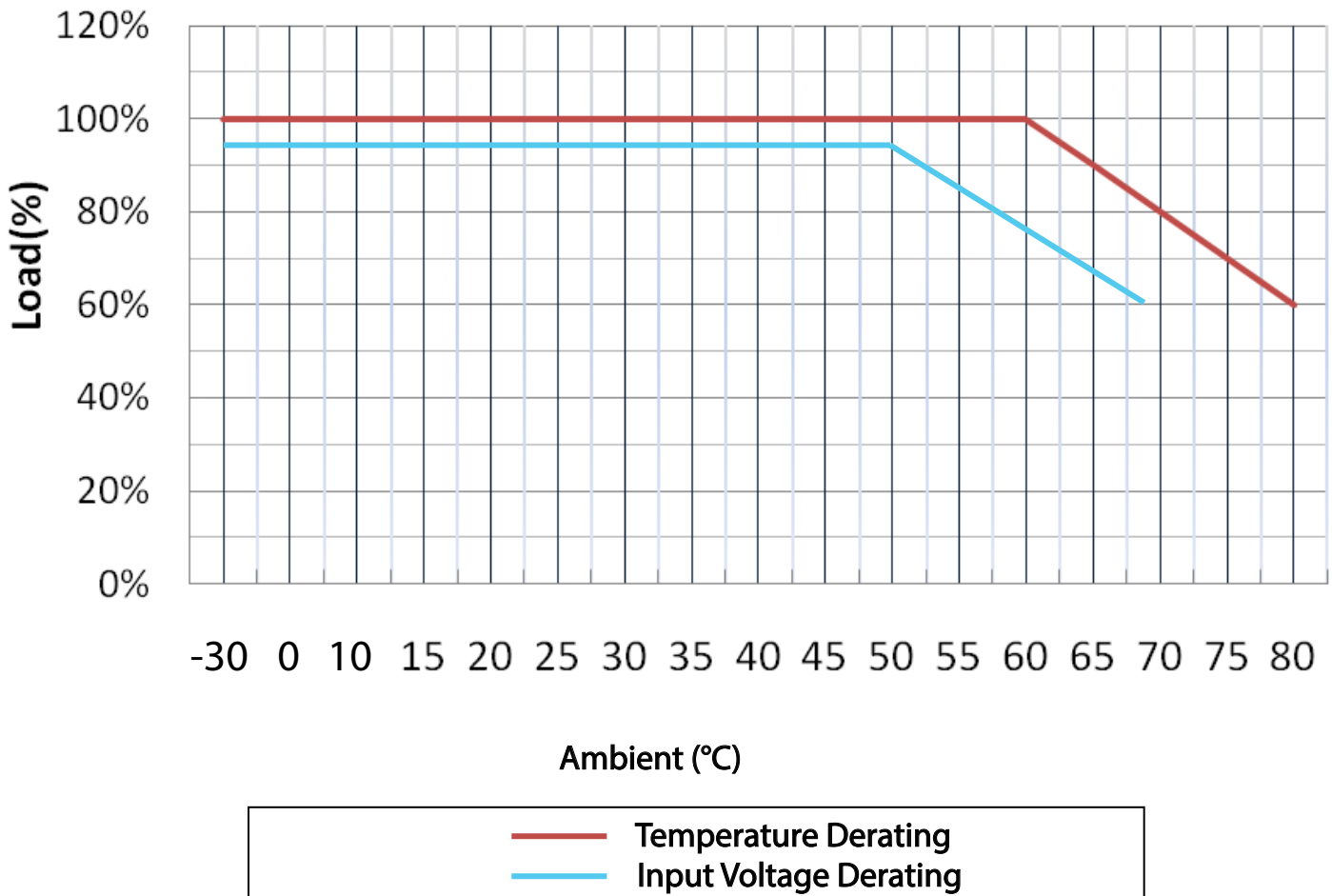

EFFICIENCY CURVE

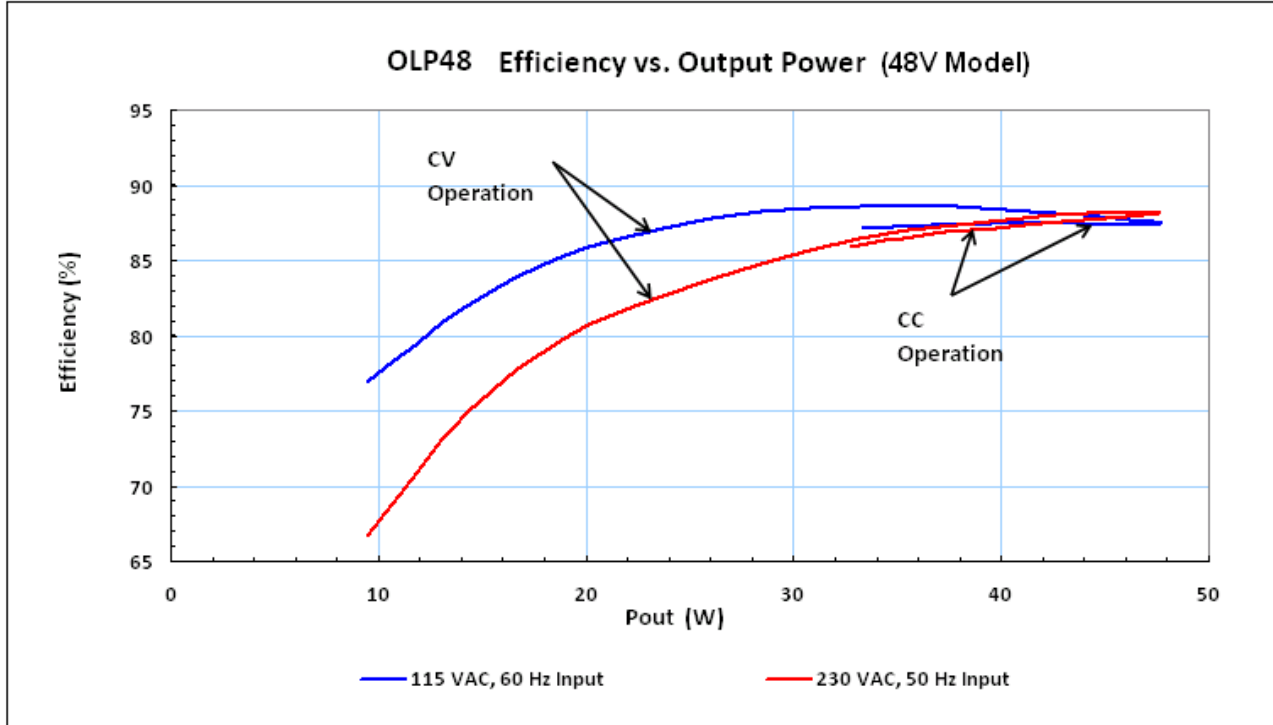

POWER LOSS CURVE

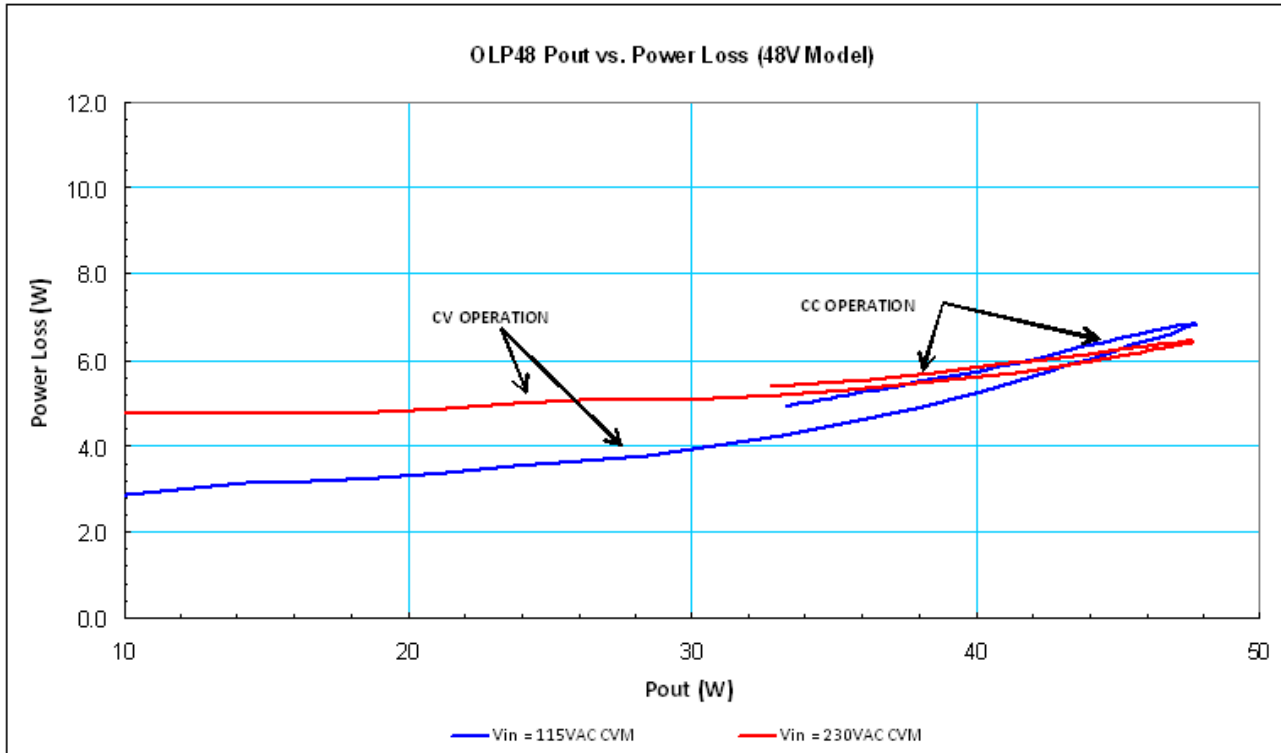

LED DRIVING METHODS CURVE

The OLP48 Series power supply can either work in "Constant Voltage (CV)" or "Constant Current (CC)" mode, to drive the LEDs.

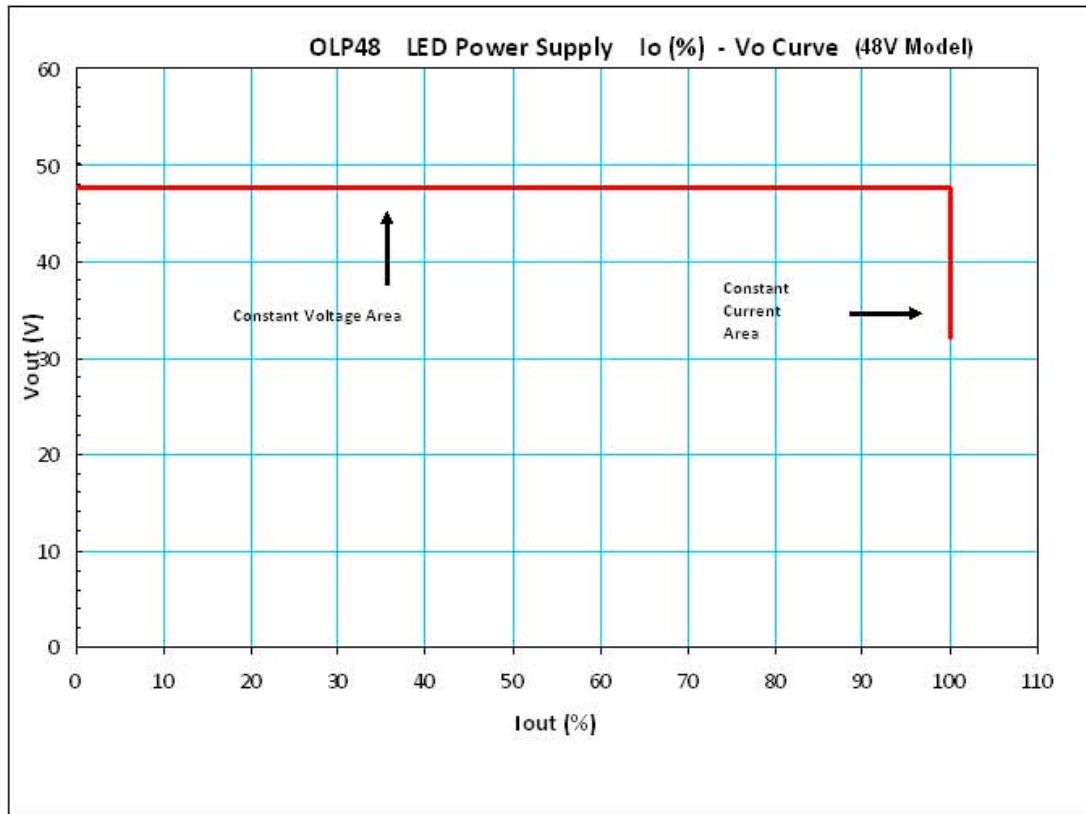

POWER FACTOR CHARACTERISTIC

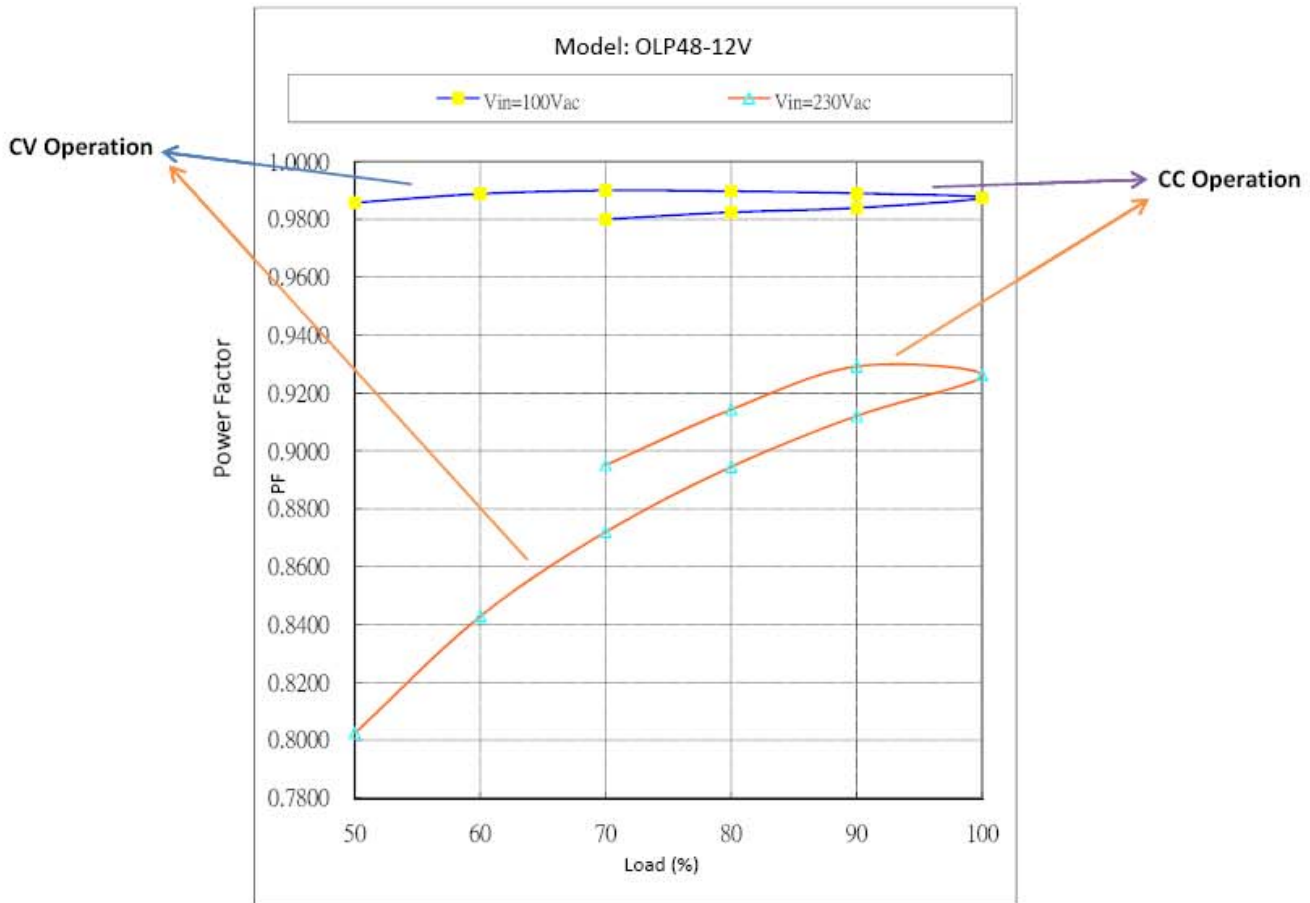

APPLICATION INFORMATION

A typical 3 Watt high brightness white LED at its operating temperature has a forward voltage drop of 3.3 volts draws 700mA. See the table below for examples.

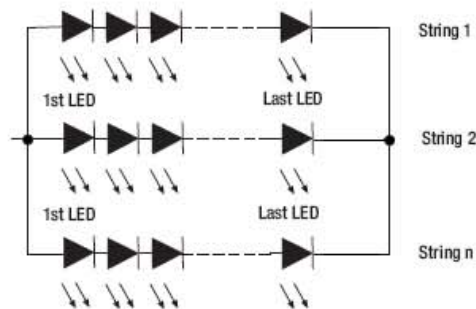

3W LEDs	LED Arrangement	AC/DC OLP48 Model
12	12 in Series	OLP48-48
14	2 Strings of 7	OLP48-24
15	5 Strings of 3	OLP48-12

Note : other LED combinations could have different forward voltage drops and operating currents. See LED datasheet specification for details.

MECHANICAL SPECIFICATION

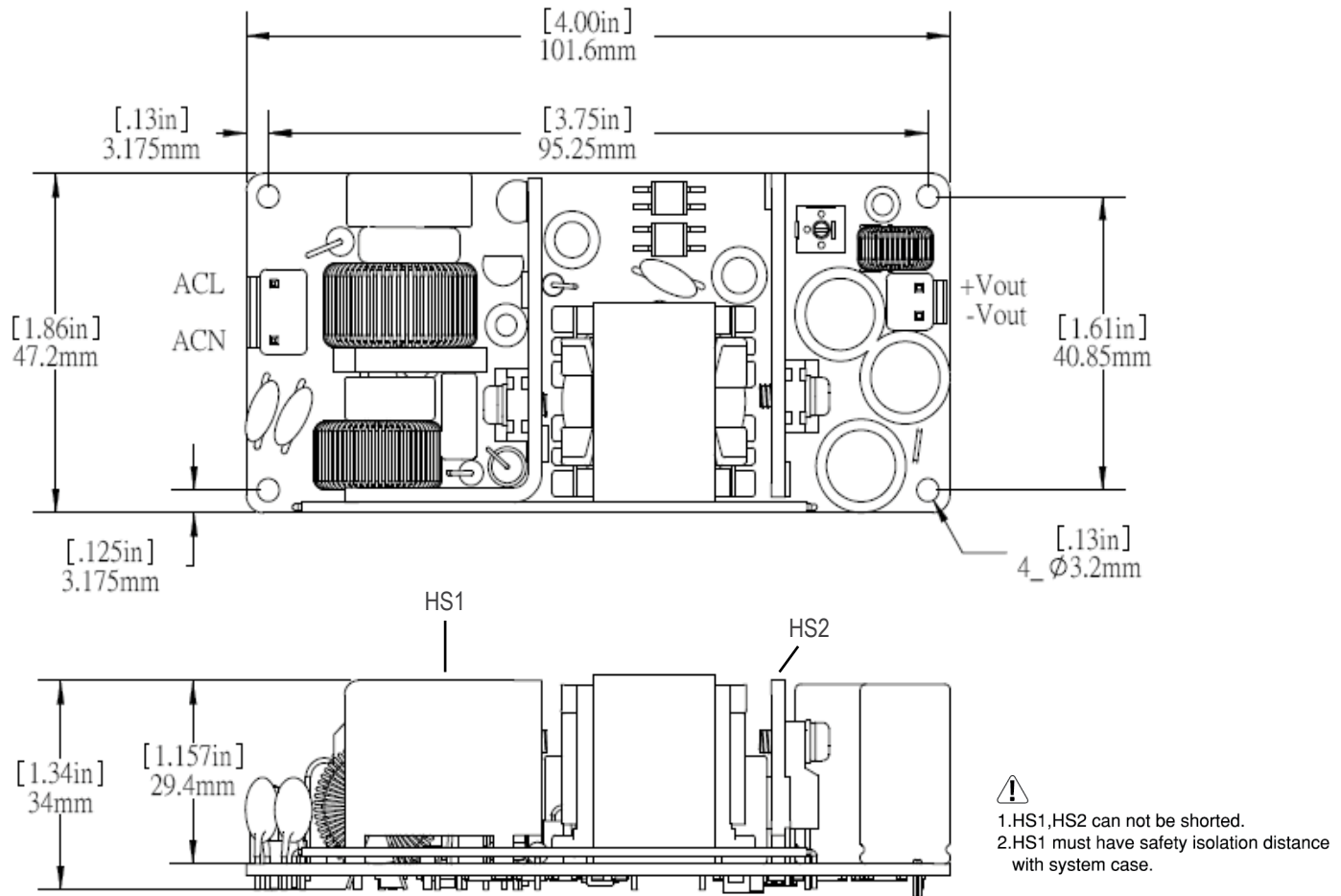

AC Input Connector (CN1) :

Pin No.	Assignment	Mating Housing	Terminal
1	AC/L	JST B3P-VH or equivalent	JST SVH-21-P1.1 or equivalent
2	No Pin		
3	AC/N		

DC Output Connector (CN2) :

Pin No.	Assignment	Mating Housing	Terminal
1	+V	JST VHR or equivalent	JST SVH-21T-P1.1 or equivalent
2	-V		