

## Single Chip Field Reprogrammable Battery Manager – Nickel Chemistries

- Single chip solution for rechargeable battery management
- Footprint compatible with PS402
- SMBus 1.1 and SBDData 1.1 compatible
- Precise capacity reporting for NiMH and NiCd battery chemistries
- Embedded Microchip patented Accuron® technology contained in customizable on-chip 16-Kbyte Flash memory
- User configurable and “learned” parameters stored in on-chip 256 x 8 EEPROM
- Algorithms and parameters fully field reprogrammable via SMBus interface
- Integrating sigma-delta A/D converter with 9 to 16-bit programmable resolution which accurately measures:
  - Current through sense resistor
  - High-voltage (18V) battery cells directly connected to VCELL inputs
  - Temperature measurement from on-chip sensor or optional external thermistor
- Integrated precision silicon time base
- Twelve individually programmable input/output pins that can be assigned as charge control I/O, secondary safety function I/O, SOC LED output or general purpose I/O
  - Two of the twelve I/Os are high-voltage, capable for direct drive of charge and safety FETs
- On-chip regulator generates precision digital and analog supply voltages directly from pack voltage
- Flexible power operating modes:
  - Run: Continuous operation
  - Sample: Periodic measurements at programmable intervals
  - Sleep: Shutdown mode due to low voltage; power consumption less than 25  $\mu$ A
  - Shelf-Sleep: Shuts off PS501-0901 power consumption for pack storage with automatic wake-up on pack insertion; power consumption is less than 1  $\mu$ A
- Integrated Reset Control
  - Power-on Reset
  - Watchdog Timer Reset
  - Brown-out Detection Reset

### Pin Description

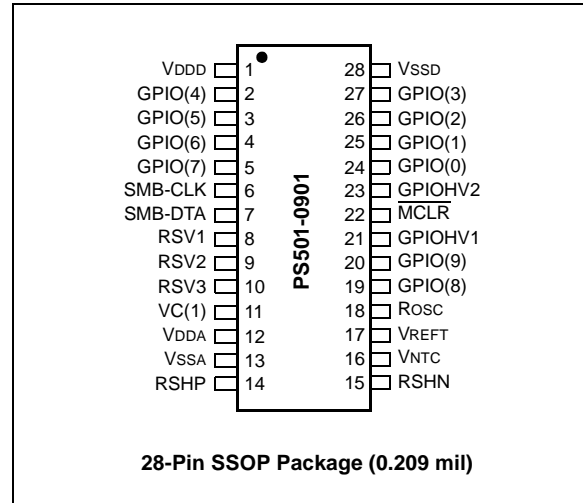

### Pin Summary

Pin Name	Type	Description
VDDD, VSSD	Supply	Digital supply voltage input, ground
GPIO(0..9)	I/O	Programmable digital I/O
GPIOHV1,2	I/O	Open-drain programmable digital I/O for direct drive of FETs
MCLR	I	Master Clear; pull-up in normal operation
SMB-CLK, SMB-DTA	I/O	SMBus interface
VC(1)	I	Pack voltage input
VDDA, VSSA	Supply	Voltage regulator output (internally connected to analog supply input); ground
RSHP, RSHN	I	Current sense resistor input
VNTC	I	External thermistor input
VREFT	O	Thermistor reference voltage
ROSC	I	Internal oscillator bias resistor
RSV1 -3	I	Reserved pins

# PS501-0901

## 1.0 PRODUCT OVERVIEW

The PS501-0901 combines a high-performance, low-power Microchip PIC18 microcontroller core, together with PowerSmart® proprietary monitor/control algorithms and 3D cell models, stored in 16 Kbytes of on-chip reprogrammable Flash memory.

Analog resources include a 16-bit sigma-delta integrating A/D and mixed signal circuitry for precision measurement of battery current, temperature and voltage. On-chip EEPROM is provided for storage of user customizable and "learned" battery parameters.

An industry standard 2-wire SMBus interface supports host communication using standard SBDData commands and status.

Additional integrated features include a high accuracy on-chip oscillator and temperature sensor. Twelve general purpose pins support charge or safety control or user programmable digital I/O. Eight of them can be used as LED drivers and two are open drain for direct FET drive.

The PS501-0901 can be configured to accommodate all Nickel rechargeable battery chemistries, including NiMH and NiCd. Nickel battery packs must contain between six and twelve series cells.

FIGURE 1-1: PS501-0901 INTERNAL BLOCK DIAGRAM

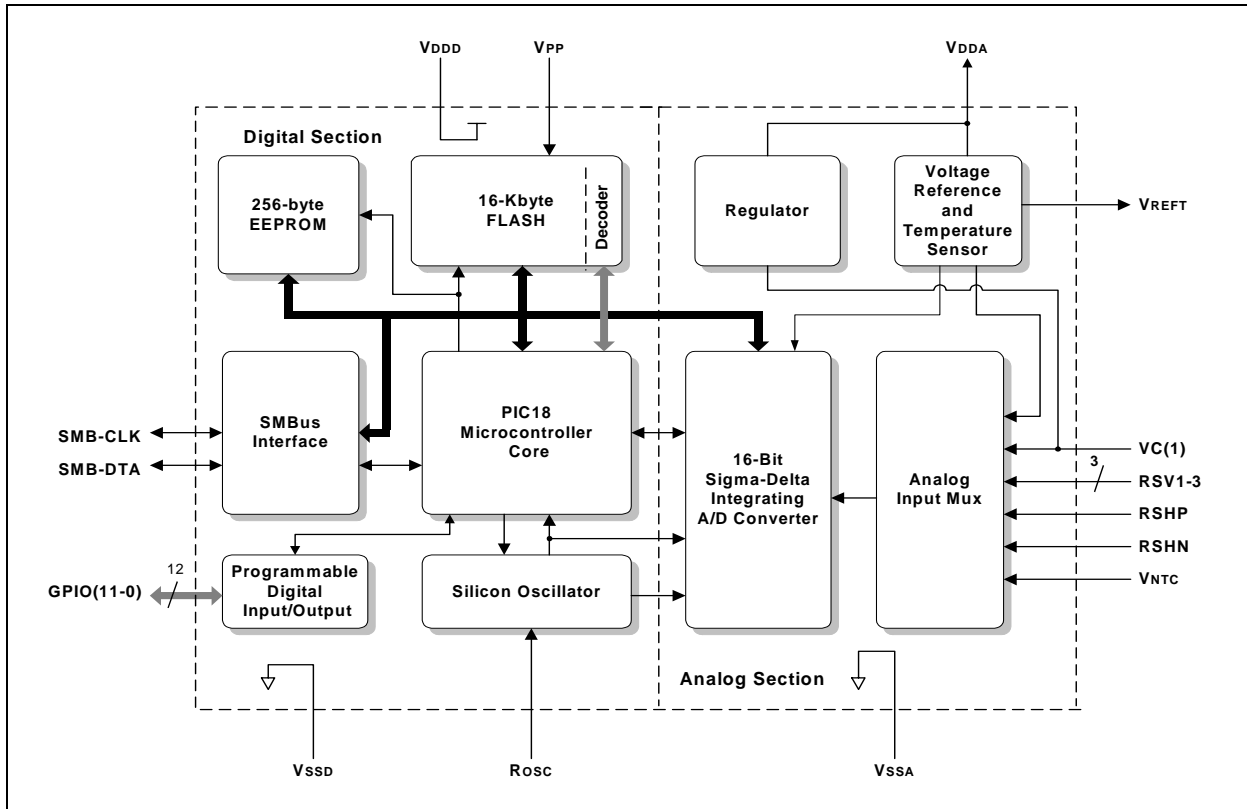

## 1.1 Architectural Description

The PS501-0901 is a fully field reprogrammable single chip solution for rechargeable battery management. Figure 1-1 is an internal block diagram highlighting the major architectural elements described below.

## 1.2 Microcontroller/Memory

The PS501-0901 incorporates an advanced, low-power Microchip PIC18 8-bit RISC microcontroller core. Memory resources include 16 Kbytes of reprogrammable Flash memory for program/data storage and 256 bytes of EEPROM for parameter storage. Both memory arrays may be reprogrammed through the SMBus interface.

## 1.3 A/D Converter

The PS501-0901 performs precise measurements of current, voltage and temperature, using a highly accurate 16-bit integrating sigma-delta A/D converter. The A/D can be calibrated to eliminate gain and offset errors and incorporates an auto-zero offset correction feature that can be performed while in the end system application.

## 1.4 Microchip Firmware/Battery Models

Contained within the 16-Kbyte Flash memory is the Microchip developed battery management firmware that incorporates proprietary algorithms and sophisticated 3-dimensional cell models. Developed by battery chemists, the patented, self-learning 3D cell models contain over 250 parameters and compensate for self-discharge, temperature and other factors. In addition, multiple capacity correction and error reducing functions are performed during charge/discharge cycles to enhance accuracy and improve fuel gauge and charge control performance. As a result, accurate battery capacity reporting and run-time predictions with less than 1% error are achievable.

The reprogrammability of the Flash allows firmware upgrades and customized versions to be rapidly created without the need for silicon revisions.

The PS501-0901 can be easily customized for a particular application's battery cell chemistry. Standard configuration files are provided by Microchip for a wide variety of popular rechargeable cells and battery pack configurations.

## 1.5 SMBus Interface/SBData Commands

Communication with the host is fully compliant with the industry standard Smart Battery System (SBS) specification. Included is an advanced SMBus communications engine that is compliant with the SMBus v1.1 protocols. The integrated firmware processes all the revised Smart Battery Data (SBData) v1.1 values.

## 1.6 Accurate Integrated Time Base

The PS501-0901 provides a highly accurate RC oscillator that provides accurate timing for self-discharge and capacity calculations and eliminates the need for an external crystal.

## 1.7 Temperature Sensing

An integrated temperature sensor is provided to minimize component count when the PS501-0901 IC is located in close physical proximity to the battery cells being monitored. As an option, a connection is provided for an external thermistor that can also be monitored.

## 1.8 General Purpose I/O

Twelve programmable digital input/output pins are provided by the PS501-0901. Eight of these pins can be used as LED outputs to display State-Of-Charge (SOC) or for direct control of external charge circuitry. Alternatively, they can be used as general purpose input/outputs. Two of the I/Os are open-drain outputs and can thus be used to directly drive FETs or other high-voltage applications.

# PS501-0901

**TABLE 1-1: PIN DESCRIPTIONS**

Pin	Name	Description
1	VDDD	(Input) Filter capacitor input for digital supply voltage.
2	GPIO(4)	(Bidirectional) Programmable general purpose digital input/output pin (4) or LED driver.
3	GPIO(5)	(Bidirectional) Programmable general purpose digital input/output pin (5) or LED driver.
4	GPIO(6)	(Bidirectional) Programmable general purpose digital input/output pin (6) or LED driver.
5	GPIO(7)	(Bidirectional) Programmable general purpose digital input/output pin (7) or LED driver.
6	SMB-CLK	SMBus clock pin connection.
7	SMB-DTA	SMBus data pin connection.
8	RSV1	Reserved – Must be connected to ground.
9	RSV2	Reserved – Must be connected to ground.
10	RSV3	Reserved – Must be connected to ground.
11	VC(1)	(Input) Pack voltage input.
12	VDDA	(Input) Analog supply voltage input.
13	VSSA	Analog ground reference point.
14	RSHP	(Input) Current measurement A/D input from positive side of the current sense resistor.
15	RSHN	(Input) Current measurement A/D input from negative side of the current sense resistor.
16	VNTC	(Input) A/D input for use with an external temperature circuit. This is the midpoint connection of a voltage divider where the upper leg is a thermistor (103ETB type) and the lower leg is a 3.65 kOhm resistor. This input should not go above 150 mV.
17	VREFT	(Output) Reference voltage output for use with temperature measuring A/D circuit. This 150 mV output is the top leg of the voltage divider and connects to an external thermistor.
18	ROSC	External bias resistor.
19	GPIO(8)	(Bidirectional) Programmable general purpose digital input/output pin (8).
20	GPIO(9)	(Bidirectional) Programmable general purpose digital input/output pin (9).
21	GPIOHV1	(Bidirectional) Programmable general purpose digital input/output pin (10). Open-drain, high-voltage tolerant.
22	MCLR	(Input) Master Clear. Must be pulled up for normal operation.
23	GPIOHV2	(Bidirectional) Programmable general purpose digital input/output pin (11). Open-drain, high-voltage tolerant.
24	GPIO(0)	(Bidirectional) Programmable general purpose digital input/output pin (0) or LED driver.
25	GPIO(1)	(Bidirectional) Programmable general purpose digital input/output pin (1) or LED driver.
26	GPIO(2)	(Bidirectional) Programmable general purpose digital input/output pin (2) or LED driver.
27	GPIO(3)	(Bidirectional) Programmable general purpose digital input/output pin (3) or LED driver.
28	VSSD	Digital ground reference point.

## 2.0 A/D OPERATION

The PS501-0901 A/D converter measures voltage, current and temperature and integrates the current over time to measure State-Of-Charge. The voltage of the entire pack is monitored and the pack is calibrated for accuracy. Using an external sense resistor, current is monitored during both charge and discharge and is integrated over time using the on-chip oscillator as the time base. Temperature is measured from the on-chip temperature sensor or an optional external thermistor. Current and temperature are also calibrated for accuracy.

### 2.1 A/D Converter List

The A/D converter alternately measures pack voltage, current, temperature and auto-offset as explained below. The schedule for the sequence and frequency of these measurements is programmable, as is the number of bits used. The default scheduling uses four lists. At near full (above the voltage point **ADLNearFull**) and near empty (below the voltage point **ADLNearEmpty**), voltage intensive lists are used to accurately end charge or discharge. In between **ADLNearFull** and **ADLNearEmpty**, a current intensive schedule is used to more accurately calculate capacity.

### 2.2 Current Measurement

The A/D input channels for current measurement are the RSHP and RSHN pins. The current is measured using an integrating method, which averages over time to get the current measurement and integrates over time to get a precise measurement value.

A 5 to 600 milliohm sense resistor is connected to RSHP and RSHN in a typical application schematic. The maximum input voltage at either RSHP or RSHN is +/-150 mV. The sense resistor should be properly sized to accommodate the lowest and highest expected charge and discharge currents, including suspend and/or standby currents.

Circuit traces from the sense resistor should be as short as practical without significant crossovers or feedthroughs. Failure to use a single ground reference point at the negative side of the sense resistor can significantly degrade current measurement accuracy.

The EEPROM value, **NullCurr**, represents the zero zone current of the battery. This is provided as a calibration guardband for reading zero current. Currents below the +/- **NullCurr** (in mA) limit are read as zero and are not included in the capacity algorithm calculations. A typical value for **NullCurr** is 3 mA, so currents between -3 mA and +3 mA will be reported as zero and not included in the capacity calculations.

The equation for current measurement resolution and sense resistor selection is shown in the following equation.

#### EQUATION 2-1:

$$9.15 \text{ mV/RSENSE (milliohms)} = \text{Current LSB}$$

(Minimum current measurement if > **NullCurr**)

$$\text{Current LSB} \times 16384 = \text{Maximum Current Measurement Possible}$$

In-circuit calibration of the current is done using the SMBus interface at time of manufacture to obtain absolute accuracy. The current measurement equation is:

#### EQUATION 2-2:

$$I(\text{ma}) = (I_{A/D} - \text{COCurr} - \text{COD}) * \text{CFCurr}/16384$$

where:  
 $I_{A/D}$  is the internal measurement

**COCurr** is the "Correction Offset for Current" which compensates for any offset error in current measurement stored in EEPROM.

**CFCurr** is the "Correction Factor for Current", which compensates for any variances in the actual sense resistance over varying currents stored in EEPROM.

Figure 2-1 shows the relationship of the **COCurr** and **CFCurr** values.

**FIGURE 2-1: COCurr AND CFCurr VALUE RELATIONSHIP**

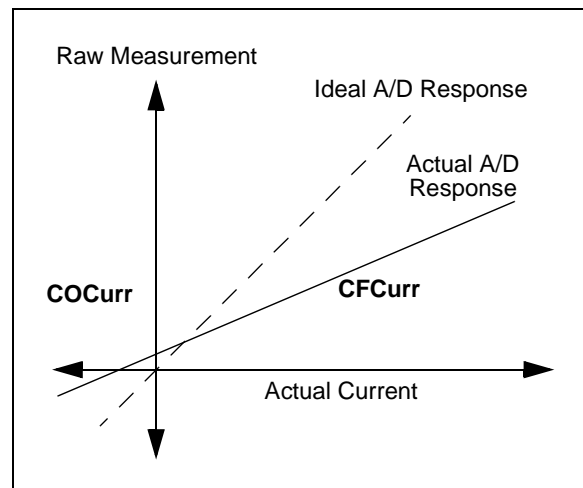

# PS501-0901

## 2.3 Auto-Offset Compensation

Accuracy drift is prevented using an automatic auto-zero self-calibration method, which 're-zeroes' the current measurement circuit every  $\text{AOMInt} * 0.5$  seconds when enabled. This feature can correct for drift in temperature during operation. The auto-offset compensation circuit works internally by disconnecting the RSHP and RSHN inputs and internally shorting these inputs to measure the zero input offset. The EEPROM and calibration value, **COD**, is the true zero offset value of the particular module.

## 2.4 Voltage Measurements

The A/D input channel for pack voltage measurements is the VC(1) pin. Measurements are taken each measurement period when the A/D is active. The maximum voltage at the VC(1) input pin is 19V absolute, but voltages above 18V are not suggested. The pack voltage is measured with an integration method to reduce any sudden spikes or fluctuations. The A/D uses an 11-bit Resolution mode for these measurements.

The pack voltage input is read twice per measurement period in Run mode. Voltage readings occur less frequently in Sample mode, where A/D measurements are not activated every measurement period, depending on the configuration of **SampleLimit** and **NSample** values. (See Section 3.0 "Operational Modes" for additional information.)

### 2.4.1 IMPEDANCE COMPENSATION

Since accurate measurement of pack voltage is critical to performance, the voltage measurements can be compensated for any impedance in the power path that might affect the voltage measurements.

The EEPROM value, **PackResistance**, is used to compensate for additional resistance that should be removed.

The equation for the compensation value (in ohms) is:

#### EQUATION 2-3:

$$\text{PackResistance} = \text{Trace Resistance} * 65535$$

(This is a 2-byte value, so the largest value is 1 ohm.)

This requires modification of overall voltage SBData function to compensate for pack resistance and shunt resistance of current sense resistor. Thus, the previous voltage equation is modified to:

#### EQUATION 2-4:

$$\text{SBData Voltage Value} = \text{VC}(1) + \text{Measured Current (mA)} * \text{PackResistance}/65535$$

The voltage measurement equation is:

#### EQUATION 2-5:

$$V \text{ (mV)} = (V_{A/D} - \text{COVPack}) * \text{CFVPack}/2048$$

where:

$V_{A/D}$  is the internal measurement output

**COVPack** is the "Correction Offset for Pack Voltage" which compensates for any offset error in voltage measurement. (Since the offset of the A/D is less than the voltage measurement resolution of +/-16.5 mV, the **COVPack** value is typically zero.)

FIGURE 2-2: PACK RESISTANCE VALUE COMPENSATIONS

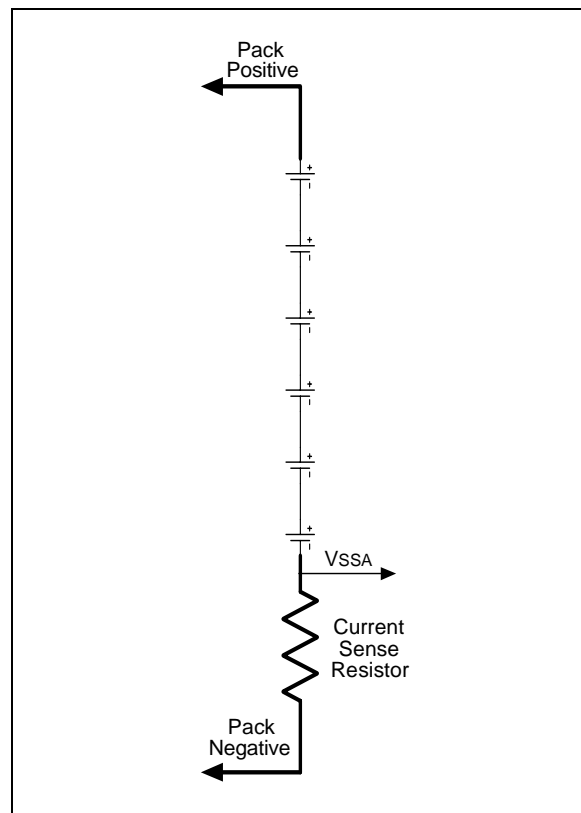

**CFVPack** is the "Correction Factor for Pack Voltage" which compensates for any variance in the actual A/D response versus an ideal A/D response over varying voltage inputs.

The **COVPack** and **CFVPack** are calibration constants that are stored in EEPROM.

Figure 2-3 shows the relationship of the **COVPack** and **CFVPack** values.

**FIGURE 2-3: COVPack AND CFVPack VALUE RELATIONSHIP**

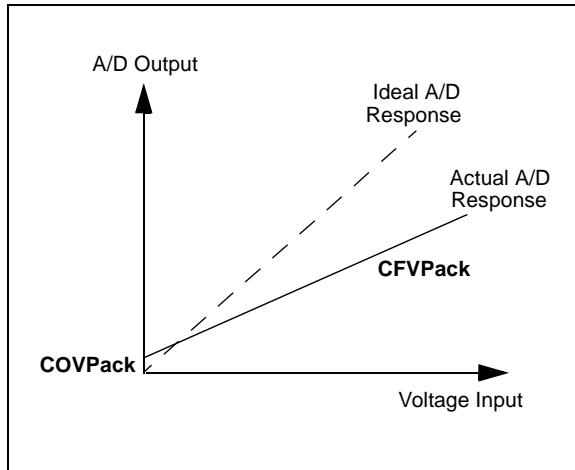

In-circuit calibration of the voltage is done at the time of manufacture to obtain absolute accuracy in addition to high resolution. Individual cell voltage measurements can be accurate to within  $\pm 20$  mV.

## 2.5 Temperature Measurements

The A/D receives input from the internal temperature sensor to measure the temperature. Optionally, an external thermistor can be connected to the VNTC pin which is also monitored by the A/D converter. An output reference voltage for use with an external thermistor is provided on the VREFT pin. The A/D uses an 11-bit Resolution mode for the temperature measurements.

A standard 10 kOhms at 25°C Negative-Temperature-Coefficient (NTC) device of the 103ETB type is suggested for the optional external thermistor. One leg of the NTC should be connected to the VREFT pin and the other to both the VNTC pin and a 3.65 kOhms resistor to analog ground (VSSA). The resistor forms the lower leg of a voltage divider circuit. To maintain high accuracy in temperature measurements, a 1% resistor should be used.

A look-up table is used to convert the voltage measurement seen at the VNTC pin to a temperature value. The external thermistor should be placed as close as possible to the battery cells and should be isolated from any other sources of heat that may affect its operation.

Calibration of the temperature measurements involves a correction factor and an offset exactly like the current and voltage measurements. The internal temperature measurement makes use of correction factor **CFTempI** and offset **COTempI**, while the VNTC and VREFT pins for the optional external thermistor make use of correction factor **CFTempE** and offset **COTempE**.

## 3.0 OPERATIONAL MODES

The PS501-0901 operates on a continuous cycle. The frequency of the cycles depends on the power mode selected. There are four power modes: Run, Sample, Sleep and Shelf-Sleep. Each mode has specific entry and exit conditions as listed below.

### 3.1 Run Mode

Whether the PS501-0901 is in Run mode or Sample mode depends on the magnitude of the current. The Run and Sample mode entry-exit threshold is calculated using the EEPROM parameter, **SampleLimit**.

**SampleLimit** is a programmable EEPROM value and **CFCurr** is an EEPROM value set by calibration.

Entry to Run mode occurs when the current is more than +/- **SampleLimit** mA for two consecutive measurements. Run mode may only be exited to Sample mode, not to Sleep mode, when Sample mode is enabled. Exit from Run mode to Sample mode occurs when the converted measured current is less than the +/- **SampleLimit** mA threshold for two consecutive measurements.

Run mode is the highest power consuming mode. During Run mode, all measurements and calculations occur once per measurement period. Current, voltage and temperature measurements are each typically made sequentially during every measurement period.

### 3.2 Sample Mode

Entry to Sample mode occurs when the measured current is less than +/- **SampleLimit** (EE parameter) two consecutive measurements. Sample mode may be exited to either Run mode or Sleep mode.

While in Sample mode, measurements of voltage, current and temperature occur only once per **NSample** counts of measurement periods, where **NSample** is a programmable EEPROM value. Calculations of State-Of-Charge, SMBus requests, etc. still continue at the normal Run mode rate, but measurements only occur once every measurement period x **NSample**. The minimum value for **NSample** is two.

The purpose of Sample mode is to reduce power consumption during periods of inactivity (low rate charge or discharge). Since the analog-to-digital converter is not active, except every **NSample** count of measurement periods, the overall power consumption is significantly reduced.

### EXAMPLE 3-1: CONFIGURATION

Measurement period is 500 ms  
**SampleLimit** is set to 20  
**NSample** is set to 16

Result:

Run/Sample Mode Entry-Exit Threshold = 20 mA

During Sample mode, measurements will occur every:

16 Measurement Periods of 500 ms = Every 8 Seconds

### 3.3 Low-Voltage Sleep Mode

Entry to Sleep mode can only occur when the measured pack voltage at the VC(1) input is below a preset limit, set by the EEPROM value **SleepVPack** (in mV). Sleep mode may be exited to Run mode, but only when one of the wake-up conditions is satisfied.

While in Sleep mode, no measurements occur and no calculations are made. The fuel gauge display is not operational, no SMBus communications are recognized and only a wake-up condition will permit an exit from Sleep mode. Sleep mode is one of the lowest power consuming modes and is used to conserve battery energy following a complete discharge.

There are two levels of Low-Voltage Sleep mode that can be used, each with a different wake-up criteria. Default Low-Power mode will use 25  $\mu$ A typical and will wake-up when the voltage exceeds the **WakeUp** voltage level. By setting bit 1 of the **WakeUp** register to '1', the Ultra Low-Power mode can be used. This will be entered by low voltage, but wake-up occurs by pulling the SMBus lines high. Ultra Low-Power mode uses less than 1  $\mu$ A.

### 3.4 Shelf-Sleep Mode

Shelf-Sleep mode is used to put the PS501-0901 into Low-Power mode, regardless of voltage level, for long term storage of battery packs. It is entered by an SMBus command. It is exited by the conditions selected in the **WakeUp** register. These can be voltage, current, GPIO or SMBus activity. If any of these four are selected for wake-up, the Shelf-Sleep mode will be Low-Power mode and will draw 25  $\mu$ A typical. If none of these options are selected and bit 3 of the **WakeUp** register is set, the Shelf-Sleep mode will be Ultra Low-Power mode, which will draw less than 1  $\mu$ A and wake-up will be by pulling SMBus high.

**TABLE 3-1: WakeUp EEPROM VALUE**

Bit	Name	Function
7	WakeIO	Wake-up from I/O Activity
6	WakeBus	Wake-up from SMBus Activity
5	WakeCurr	Wake-up from Current
4	WakeVolt	Wake-up from Voltage
3	Enable Shelf-Sleep	Use Ultra Low-Power mode for Shelf-Sleep mode. All other bits must be zero.
1	LV Sleep Mode	Use Ultra Low-Power mode as Low-Voltage Sleep mode
0	Zero Remcap	Set Remcap to zero when entering Low-Voltage Sleep mode

**TABLE 3-2: WakeLevels EEPROM VALUE**

WakeUp Voltage (2:0)	Voltage	Purpose
000	6.4V	2 cells Li Ion
001	6.66V	6 cells NiMH
010	8.88V	8 cells NiMH
011	9.6V	3 cells Li Ion
100	9.99V	9 cells NiMH
101	11.1V	10 cells NiMH
110	12.8V	4 cells Li Ion
111	13.3V	12 cells NiMH
WakeUp Current (7:3)	Voltage	Purpose
00000	Minimum	μV across Sense Resistor
11000	Typical Recommended	μV across Sense Resistor
11111	Maximum	μV across Sense Resistor

**TABLE 3-3: POWER MODE SUMMARY**

Mode	Entry	Exit	Notes
Run	Measured current > preset threshold (set by <b>SampleLimit</b> )	Measured current < preset threshold (set by <b>SampleLimit</b> )	Highest power consumption and accuracy for rapidly changing current.
Sample	Measured current < preset threshold (set by <b>SampleLimit</b> )	Measured current > preset threshold (set by <b>SampleLimit</b> )	Saves power for low, steady current consumption. Not as many measurements needed. Measurements made every <b>NSample</b> periods.
Sleep	VC(1) < <b>SleepVPack</b> and in Sample mode	<b>WakeUp</b> voltage level exceeded (Low-Power mode) or SMBus pulled high (Ultra Low-Power mode)	No measurements made.
Shelf-Sleep	SMBus command	<b>WakeUp</b> register conditions met (Low-Power mode) or SMBus pins pulled high (Ultra Low-Power mode)	No measurements made.

## 4.0 CAPACITY MONITORING

The PS501-0901 internal CPU uses the voltage, current and temperature data from the A/D converter, along with parameters and cell models to determine the state of the battery and to process the SBDData function instruction set.

By integrating measured current, monitoring voltages and temperature, adjusting for self-discharge and checking for End-Of-Charge and End-Of-Discharge conditions, the PS501-0901 creates an accurate fuel gauge under all battery conditions.

### 4.1 Capacity Calculations

The PS501-0901 calculates State-Of-Charge and fuel gauging functions using a 'coulomb counting' method, with additional inputs from battery voltage and temperature measurements. By continuously and accurately measuring all the current into and out of the battery cells, along with accurate three-dimensional cell models, the PS501-0901 is able to provide accurate predictions of SOC and run time.

The capacity calculations consider two separate states: charge acceptance or Capacity Increasing (CI) and discharge or Capacity Decreasing (CD). The CI state only occurs when a charge current larger than EEPROM **NullCurr** value is measured. Otherwise, while at rest and/or while being discharged, the state is CD. Conditions must persist for at least **NChangeState** measurement periods for a valid state change between CD and CI. A minimum value of 2 is suggested for **NChangeState**.

Regardless of the CI or CD state, self-discharge is also calculated and subtracted from the integrated capacity values. Even when charging, there is still a self-discharge occurring in the battery.

To compensate for known system errors in the capacity calculations, a separate error term is also continuously calculated. This term is the basis for the SBDData value of **MaxError**. Two error values are located in EEPROM. The **CurrError** value is the inherent error in current measurements and should be set based on the selection of a sense resistor and calibration results. The **SelfDischrgErr** value is the error in the parameter tables for self-discharge and depends on the accuracy of the cell chemistry model for self-discharge.

Since the PS501-0901 electronics also drain current from the battery system, another EEPROM value allows even this minor drain to be included in the capacity calculations. The **PwrConsumption** value represents the drain of the IC and associated circuitry, including additional safety monitoring electronics, if present. A typical value of 77 represents the module's nominal power consumption, including the PS501-0901 typical consumption.

The total capacity added or subtracted from the battery (change in charge) per measurement period is expressed by the following formula:

#### EQUATION 4-1:

$$\Delta\text{Charge} = \Sigma i\Delta t \text{ (the current integrated over time)}$$

- **CurrError** (Current Measurement Error)
- **PwrConsumption** \*  $\Delta t$  (PS501-0901 IDD)
- % of Self-Discharge \* FCC
- **SelfDischrgErr** (Self-Discharge Error)

The error terms are always subtracted, even though they are +/- errors, so that the fuel gauge value will never be overestimated. Current draw of the PS501-0901 and the self-discharge terms are also always subtracted. The SBDData value **MaxError** is the total accumulated error as the gas gauge is running.

The battery current will be precisely measured and integrated in order to calculate total charge removed from or added to the battery. Based on look-up table values, the capacity is adjusted with self-discharge relative to current, temperature and SOC.

### 4.2 Discharge Termination

Discharge termination is determined based on the End-Of-Discharge (EOD) voltage point. The voltage level at which this point occurs can be chosen to be constant, or to change, depending on the temperature and discharge rate, since these factors affect the voltage curve and total capacity of the battery. The EOD voltage parameter table predicts the voltage point at which this EOD will be reached, based on discharge rate and temperature.

The PS501-0901 will monitor temperature and discharge rate continuously and update the VEODx in real time. When the voltage measured on the pack is below EOD voltage for the duration of **EODRecheck** x periods (500 ms), a valid EOD has occurred.

When a valid EOD has been reached, the **TERMINATE\_DISCHARGE\_ALARM** bit (bit 11) in **BatteryStatus** will be set. This will cause an **AlarmWarning** condition with this bit set.

Additionally, the **REMAINING\_TIME\_ALARM** and/or **REMAINING\_CAPACITY\_ALARM** bits can be set first to give a user defined early warning prior to the **TERMINATE\_DISCHARGE\_ALARM**.

The **REMAINING\_TIME\_ALARM** will trigger in **BatteryStatus** when the remaining time calculation falls below a threshold set by the SMBus command. The **REMAINING\_CAPACITY\_ALARM** will be set in **BatteryStatus** when the capacity falls below a threshold set by the SMBus command. Use an SMBus write command to **RemainingTimeAlarm** (command code 0x02) or **RemainingCapacityAlarm** (command code 0x01) to set these values.

### 4.3 Capacity Relearn at Discharge Termination

To maintain accurate capacity prediction ability, the **FullCapacity** value is relearned on each discharge, which has reached a valid EOD after a previous valid fully charged condition (EOC). If a partial charge occurs before reaching a valid EOD, then no relearn will occur. If the discharge rate at EOD is greater than the 'C-rate' adjusted value in **RelearnCurrLim**, then no relearn will occur.

When a valid EOD has been reached, then the error calculations represented by the **SBDData** value of **MaxError** will be cleared to zero. If appropriate, the relearned value of **FullCapacity** (and **FullChargeCapacity**) will also be updated at this time.

### 4.4 Discharge Termination Voltage Look-up Table

#### 4.4.1 NEAR EMPTY SHUTDOWN POINT

As the graph in Table 4-1 shows, available capacity in the battery varies with temperature and discharge rate. Since the remaining capacity will vary, the save to disk point of a PC will also vary with temperature and discharge rate.

Knowing the discharge rate that occurs in the system during the shutdown process and knowing the temperature can pinpoint the exact shutdown point that will always leave the perfect shutdown capacity. The PS501-0901 uses this information to tailor the gas gauge to the system and the remaining capacity and RSOC fuel gauge function will always go to zero at the efficient shutdown point. The table will use the voltage points at which this happens as the error correction and **FullCapacity** relearn point. This will ensure a relearn point before shutdown occurs and will correct any error in remaining capacity, also to ensure proper shutdown reserve energy.

The shutdown point has to equal the capacity required to shut down the system under the conditions of the shutdown. That is, looking at the curve that represents the actual discharge C-rate that occurs during the system shutdown function, we must stop discharge and initiate shutdown when the system has used capacity equal to that point on the shutdown C-rate curve. Therefore, no matter what the C-rate is when the shutdown point is reached, the system will automatically switch to the C-rate curve that represents the actual current draw of the shutdown function. It doesn't matter if the system is in high discharge, or low discharge, it will be in "shutdown" discharge conditions when shutdown begins and there must be enough capacity left. An example is a computer's save to disk function.

Table 4-1 shows that the system will always shut down at the same capacity point regardless of C-rate conditions (since the C-rate of the shutdown procedure is a constant). Thus, we can automatically have an RSOC that is compensated for C-rate; it will go to zero when the capacity used is equal to the point at which shutdown occurs.

Ignoring the effects of temperature, we could mark the capacity used up to the shutdown point of the shutdown curve. All of the shutdown voltage points would then represent the same capacity and RSOC would always become zero at this capacity; FCC would always equal this capacity plus the residual capacity of the shutdown curve.

To compensate for temperature, we can look at the series of curves that represent the shutdown C-rate at different temperatures. The PS501-0901 implementation is to measure the temperature and choose a scaled RSOC value that will go to zero at the shutdown point at this temperature, assuming the temperature does not change. If it does change, then an adjustment to RSOC will be needed to make it go to zero at the shutdown point.

Taking temperature into consideration, the amount of capacity that can be used before shutdown is a constant as C-rate changes, but not constant as temperature changes. Thus, in the Look-up Table (LUT), the individual temperature columns will have voltage points that all represent the same capacity used, but the rows across temperature points (C-rate rows) will represent the different capacity used.

To compensate RSOC and RM, interpolation will be used and the compensation adjustment can happen in real time to avoid sudden drops or jumps. Every time the temperature decreases by one degree, a new interpolated value will be subtracted from RSOC and RM. Every time the temperature increases by one degree, RSOC and RM will be held constant until the discharged capacity equals the interpolated value that should have been added to RSOC and RM (to avoid capacity increases during discharge). With this interpolation happening in real time, there will be no big jumps or extended flat periods as we cross over boundaries in the LUT. This compensation will not begin until after the fully charged status is reset, allowing RSOC to be 100% always when the battery is full.

### 4.5 Age Compensation

The voltage EOD points will be compensated due to the age of the cells. A linear factor, **AgeFactor**, will be applied to the voltage points as a function of **CycleCount**. The voltage levels will decrease as the battery pack ages to model the flattening of the voltage vs. capacity curve that naturally happens to battery cells.

# PS501-0901

**TABLE 4-1: V\_EOD LOOK-UP TABLE**

	<0°	<4°	<10°	<17°	<24°	<40°	<44°	>44°
<0.2C	V1	V2	V3	—				
<0.5C								
<0.8C								
<1.1C								
<1.4C								
<1.7C								
<2.0C								
<2.0C					—	V62	V63	V64
Capacity	15%	13%	11%	9%	7%	5%	3%	1%

The above table is an example of the various voltage values that will signal the shutdown points as a function of temperature and discharge rate. Also shown is the amount of capacity left after shutdown that will compensate RSOC.

Table 4-2 shows the actual names of the values in the EEPROM.

**TABLE 4-2: VALUE NAMES IN THE EEPROM**

	TEOD(1)	TEOD(2)	TEOD(3)	TEOD(4)	TEOD(5)	TEOD(6)	TEOD(7)	TEOD(8)
CEOD(1)	VEOD1(1)	VEOD1(2)	VEOD1(3)	VEOD1(4)	VEOD1(5)	VEOD1(6)	VEOD1(7)	VEOD1(8)
CEOD(2)	VEOD2(1)	VEOD2(2)	VEOD2(3)	VEOD2(4)	VEOD2(5)	VEOD2(6)	VEOD2(7)	VEOD2(8)
CEOD(3)	VEOD3(1)	VEOD3(2)	VEOD3(3)	VEOD3(4)	VEOD3(5)	VEOD3(6)	VEOD3(7)	VEOD3(8)
CEOD(4)	VEOD4(1)	VEOD4(2)	VEOD4(3)	VEOD4(4)	VEOD4(5)	VEOD4(6)	VEOD4(7)	VEOD4(8)
CEOD(5)	VEOD5(1)	VEOD5(2)	VEOD5(3)	VEOD5(4)	VEOD5(5)	VEOD5(6)	VEOD5(7)	VEOD5(8)
CEOD(6)	VEOD6(1)	VEOD6(2)	VEOD6(3)	VEOD6(4)	VEOD6(5)	VEOD6(6)	VEOD6(7)	VEOD6(8)
CEOD(7)	VEOD7(1)	VEOD7(2)	VEOD7(3)	VEOD7(4)	VEOD7(5)	VEOD7(6)	VEOD7(7)	VEOD7(8)
CEOD(8)	VEOD8(1)	VEOD8(2)	VEOD8(3)	VEOD8(4)	VEOD8(5)	VEOD8(6)	VEOD8(7)	VEOD8(8)
	FCCP(1)	FCCP(2)	FCCP(3)	FCCP(4)	FCCP(5)	FCCP(6)	FCCP(7)	FCCP(8)

**TABLE 4-3: VALUE DEFINITIONS IN THE EEPROM**

<b>TEOD</b> 8 coded bytes	typ: 50, 62, 75, 94, 112, 150, 162	Range: 1-255 per byte
EOD temperature boundaries, 8 increasing values of temperature coded as TEODx = (Tcelsius * 10 + 200)/4		
<b>CEOD</b> 8 coded bytes	typ: 16, 24, 32, 43, 53, 64, 72	Range: 1-255
EOC C-rate boundaries, 8 increasing values of C-rates coded: CEODx = C-rate * (256/28/Rf), where Rf is the Rate Factor (RFACOR) EEPROM parameter. For Rf = 7, CEODx = C-rate * 64. Thus, a value of 32 is one-half C, etc.		
<b>FCCP</b> coded %	typ: 40, 35, 30, 25, 20, 15, 10, 5	Range: 1-255
Unusable residual capacity before save to disk, corresponding to temperature, 255 = 100%		
<b>VEOD</b> coded	typ: 75	Range: 1-255
End-Of-Discharge voltage, voltage = (VEOD * 2 + 700) * (# series cells). Pack voltage at which shutdown is signaled.		

## 5.0 CHARGE CONTROL

An SBS configuration normally allows the Smart Battery to broadcast the ChargingVoltage and ChargingCurrent values to the Smart Battery Charger (SMBus address 12 hex) to 'control' when to start charge, stop charge and when to signal a valid 'fully charged' condition. AlarmWarnings are also sent from the Smart Battery (SMBus address 16 hex) to the Smart Battery Charger.

Alternately, the SMBus host, or a "Level 3" Smart Battery Charger, may simply read the SBDData values for ChargingVoltage and ChargingCurrent from the Smart Battery directly. The host or "Level 3" Smart Battery Charger is also required to read the SBDData value of BatteryStatus to obtain the appropriate alarm and status bit flags. When used in this configuration, the ChargingCurrent and ChargingVoltage broadcasts can be disabled from the Smart Battery by setting the CHARGER\_MODE (bit 14) in the BatteryMode register. The PS501-0901 ICs support all of these functions. (Please refer to the SBS Smart Battery Charger specification for a definition of the "Level 3" Smart Battery Charger.)

The ChargingCurrent and ChargingVoltage registers contain the maximum charging parameters desired by the particular chemistry, configuration and environmental conditions. The environmental conditions include the measured temperature and the measured cell or pack voltages.

For Ni-based systems, ChargingVoltage should be set to 65535. This value indicates that the Smart Battery Charger should operate as a current source outside its maximum regulated voltage range.

The ChargingCurrent value is set to a maximum using the **ChrgCurr** value from the EEPROM and to a minimum using the **ChrgCurrOff** value. The value of ChargingCurrent may change when the temperature limits are exceeded during charge. When a valid End-Of-Charge (EOC) condition is detected and a fully charged state is reached, the ChargingCurrent value is set to the **ChrgCurrOff** value.

When ChargingCurrent is set to the **ChrgCurrOff** value, no broadcasts of either ChargingCurrent or ChargingVoltage will occur unless a charge current greater than **NullCurr** is detected by the A/D measurements. Temperature limits are set using the **ChrgMaxTemp**, **DischrgMaxTemp** and **ChrgMinTemp** values from EEPROM. These values represent the temperature limits within which ChargingCurrent will be set to **ChrgCurr**. Temperatures outside these limits will cause ChargingCurrent to be set to **ChrgCurrOff**.

If ChargingCurrent is set to **ChrgCurrOff** and the measured temperature is greater than **DischrgMaxTemp** and less than **ChrgMaxTemp** and a charge current is measured which is significantly larger than the

**ChrgCurrOff** value, then ChargingCurrent will be set to **ChrgCurr** unless a fully charged condition has already been reached.

If the CHARGER\_MODE bit in the BatteryMode register is cleared (enabling broadcasts of ChargingCurrent and ChargingVoltage), then these broadcasts will occur every **NChrgBroadcast** measurement cycle.

The Smart Battery Data and Smart Battery Charger specifications require that ChargingCurrent and ChargingVoltage broadcasts occur no faster than once per 5 seconds and no slower than once per 60 seconds when charging is occurring or desired. This requires that the **NChrgBroadcast** value must be set between 10 and 120. The SMBus specification also requires that no broadcasts occur during the first 10 seconds after SMBus initialization.

### EXAMPLE 5-1: CHARGE CONTROL

Measurement cycle is 500 msec  
**NChrgBroadcast** = 100 decimal  
**ChrgCurr** = 2500 decimal  
**ChrgCurrOff** = 10 decimal  
**ChrgMaxTemp** = 162 decimal  
**DischrgMaxTemp** = 137 decimal  
**ChrgMinTemp** = 50 decimal

Results:

ChargingCurrent and ChargingVoltage broadcasts:

100 cycles of 500 msec = every 50 seconds

Broadcast delay after SMBus initialization:

10 seconds

ChargingCurrent if Temperature > 45°C: 10 mA

ChargingCurrent if Temperature < 0°C: 10 mA

ChargingCurrent if Temperature < 35°C and > 0°C: 2500 mA

### 5.1 Full Charge Detection Methods

The PS501-0901 monitors pack voltage and temperature to determine the battery full End-Of-Charge (EOC) condition. There are five possible fully charged EOC conditions that are monitored according to control parameters. These methods are designed to detect a fully charged battery over a range of operating temperatures and charge rates. Figure 5-1 gives a summary of the EOC algorithm. **ConfigEOC** is used to choose which EOC methods will be monitored. A detailed parameter explanation for all of the full charge detection parameters is in **Section 8.0 "Parameter Setup"**.

FIGURE 5-1: EOC OVERVIEW FLOW CHART

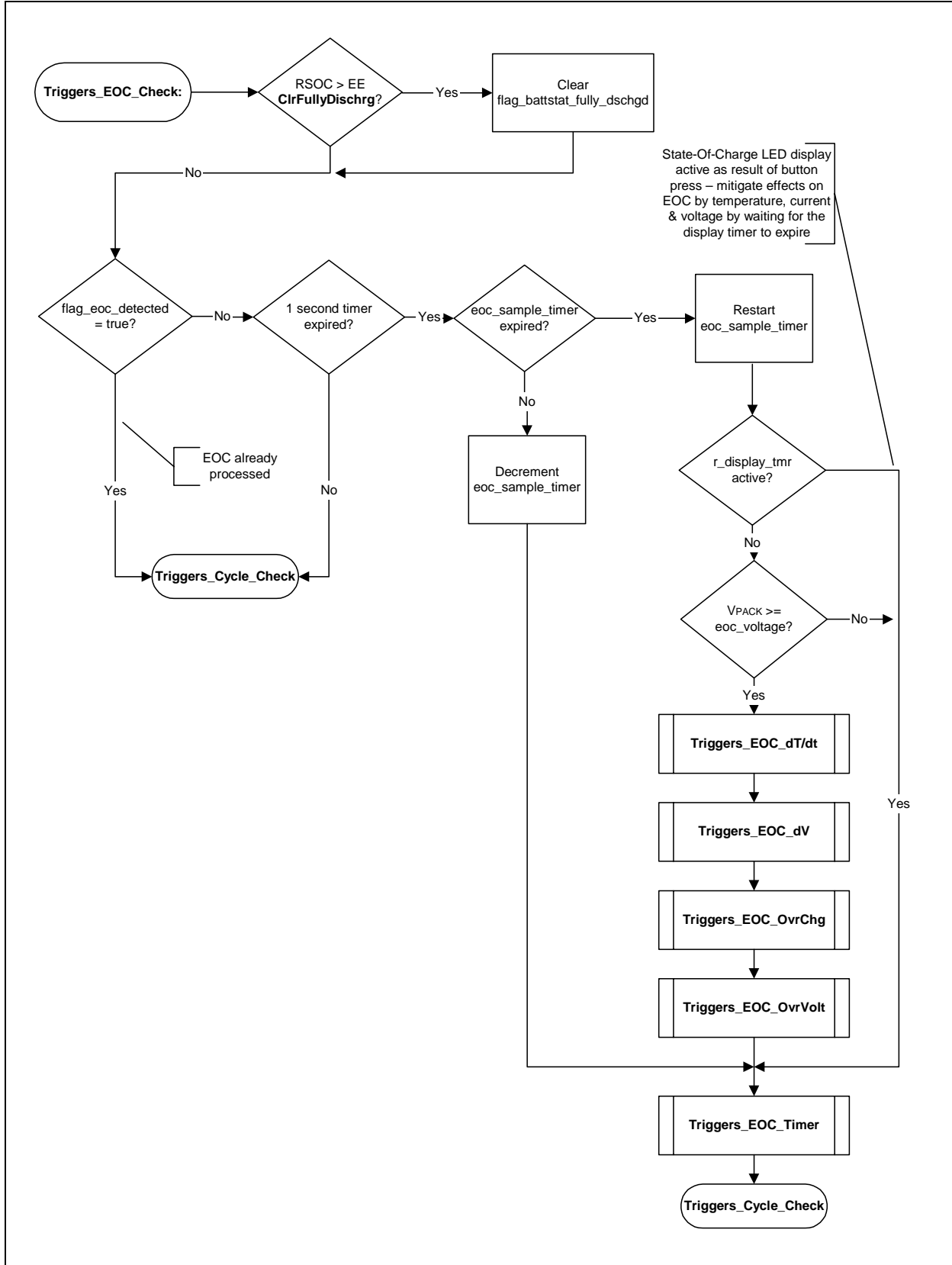

When a valid, fully charged EOC condition is detected, regardless of the detection method, the following actions occur:

- The FULLY\_CHARGED status bit (bit 5) in the SBData value of BatteryStatus is set to '1' to indicate a full condition. (This will remain set until RelativeStateOfCharge drops below the **ClrFullyChrg** value in EEPROM.)
- RelativeStateOfCharge is set to 100% except when EOC is triggered by dT/dt and it is set to 95%.
- ChargingCurrent is set to **ChrgCurrOff** value.
- SBData value for MaxError is cleared to zero percent (0%).
- The TERMINATE\_CHARGE\_ALARM bit (bit 14) is set in BatteryStatus and an AlarmWarning broadcast is sent to the SMBus host and Smart Battery Charger addresses.
- The **OverChrg** value is incremented for any charge received above 100% after a valid fully charged EOC condition.
- Control flags for internal operations are set to indicate a valid full charge condition was achieved.
- Other BatteryStatus or AlarmWarning flag bits may also be set depending on the conditions causing the EOC.
  - The charge timer, **EOCTimer**, is exceeded
  - Cell voltage is higher than **TCAVolt**

## 5.1.1 TEMPERATURE EOC

The rate of rise of the battery temperature is the first and primary full charge detection mechanism. This is a well known method used for Nickel-based chemistries and is commonly referenced as the "dT/dt" method (delta-Temperature over delta-time). The rate of temperature rise over a finite period of time is continually monitored. A rapid increase at an inflection point is detected as End-Of-Charge point. This inflection point is usually seen just before a fully charged state, so the resulting State-Of-Charge (SOC) Reset may be slightly less than 100%. Typically, a dT/dt rate of 1°C per minute can accurately detect the 95% full point when used with charging rates near the 1°C or 1 hour rate. Although this method is active during any charge rate, it typically only occurs for charge rates of 0.8°C or higher. Figure 5-2 gives an overview of the temperature EOC algorithm.

FIGURE 5-2: dT/dt FLOW CHART

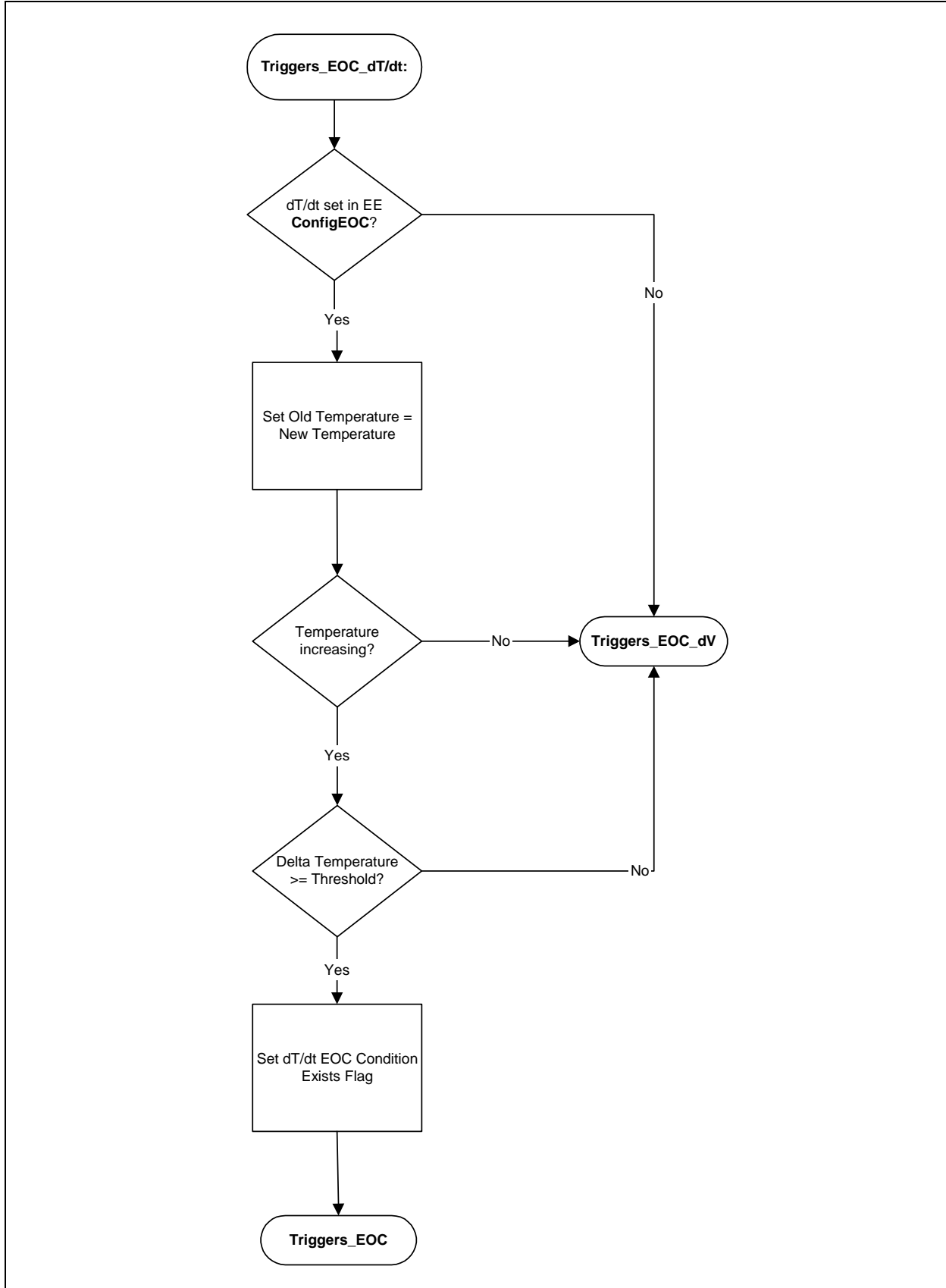

All of the control parameters regarding a temperature (dT/dt) EOC are available for customizing:

**TABLE 5-1: dT/dt CONTROL PARAMETERS**

Parameter	Description
<b>EOCdTSOC</b>	SOC Reset value when a dT/dt EOC condition occurs
<b>EOCdTTemp</b>	Minimum temperature change between two samples to cause EOC

## 5.1.2 VOLTAGE DROP EOC

The second full charge detection mechanism looks for a negative voltage drop after reaching a peak. This is also an established method for Nickel-based chemistries and is termed the “-dV” method (negative delta-V). Just at the point of full charge, the voltage profile of the battery cells will start to drop from a peak value. This drop, if measured while the current remains stable, indicates a 100% full charge condition. Generally, a -10 mV per cell drop occurs. Charge rates above 0.5°C are typically required to cause this method to be observed. This voltage drop method looks for a total pack voltage drop. If the charge current is stable and the voltage drops the programmed amount, a full charge EOC is signaled. Figure 5-3 gives an overview of the voltage drop EOC algorithm.

FIGURE 5-3: -dV FLOW CHART

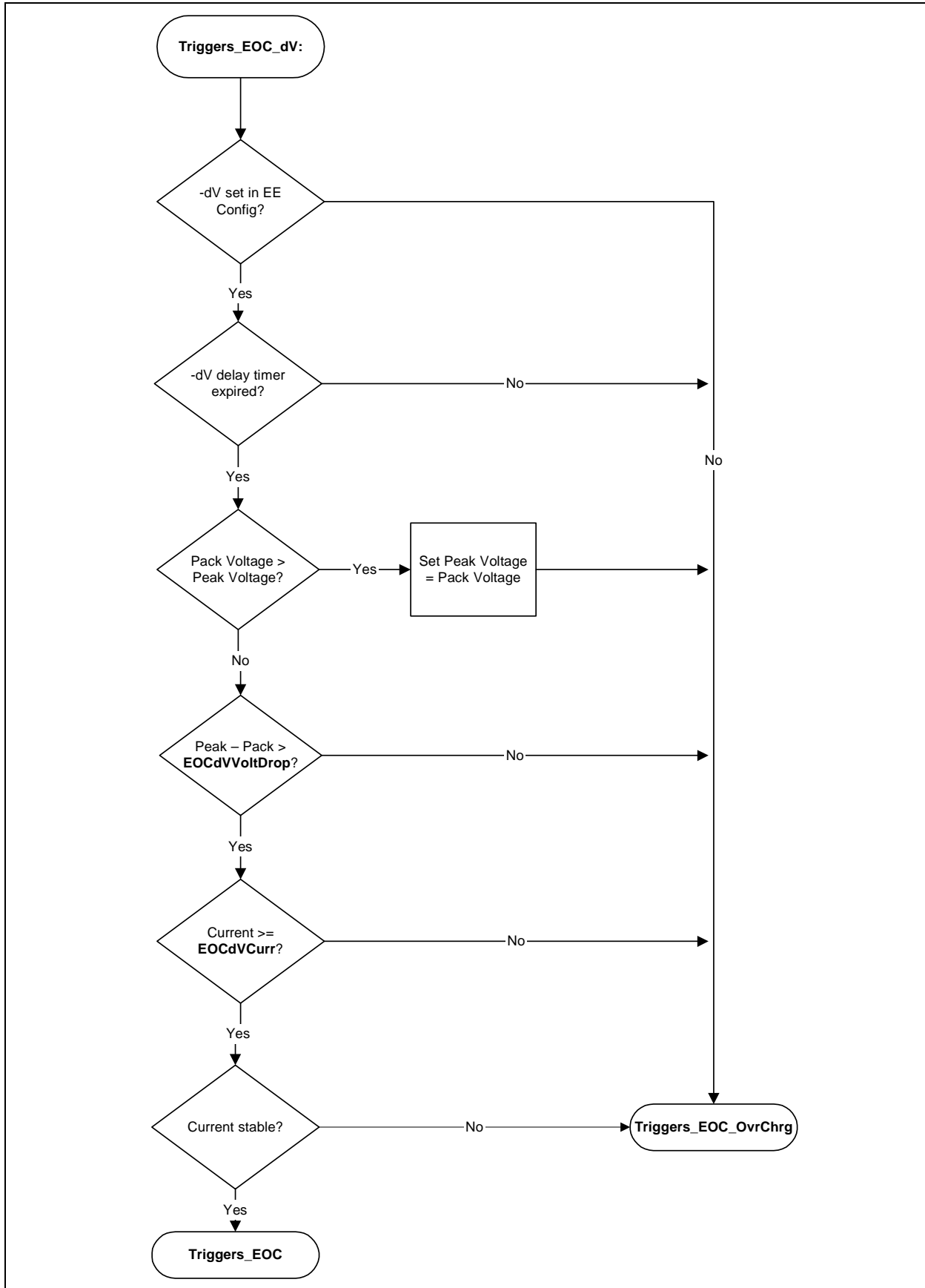

All of the control parameters regarding a voltage drop (-dV) EOC are available for customizing:

**TABLE 5-2: -dV CONTROL PARAMETERS**

Parameter	Description
<b>EOCdVCurr</b>	Minimum charge current required to enable -dV EOC
<b>EOCdVDelay</b>	Delay prior to -dV samples
<b>EOCdVVoltDrop</b>	Minimum voltage drop required to trigger EOC

### 5.1.3 FIXED OVERCHARGE EOC

When charging at low rates, neither of the previously mentioned full charge EOC conditions may occur. Since there are no signals from the battery temperature, voltage or current to aid in determining a full charge, a simple 'count' mechanism is used. By simply integrating the total charge that has entered the battery cells, a fixed amount of overcharge can signal a full charge EOC condition. For Nickel-based chemistries, this varies between 20 and 50% of their rated capacity. Typically, at charge rates less than 0.4C, neither the dT/dt or -dV EOC methods will occur. An accumulated charge of 120 to 150% of the last full charge capacity is a good indicator of full charge. This fixed amount of overcharge method is reliable for low rate charging, or long term charging, since it effectively serves as a charge timer as well.

### 5.1.4 TIMER EOC

The overcharging of Nickel batteries, even by trickle charging, causes deterioration in the characteristics of the batteries. To prevent overcharging, an EOC timer can be used to discontinue charging when the charge time has exceeded **EOCTimeout**.

## 5.2 Temperature Algorithms

The PS501-0901 SMBus Smart Battery IC provides multiple temperature alarm set points and charging conditions. The following EEPROM parameters control how the temperature alarms and charging conditions operate.

**HighTempAl:** When the measured temperature is greater than **HighTempAl**, the **OVER\_TEMP\_ALARM** is set. If the battery is charging, then the **TERMINATE\_CHARGE\_ALARM** is also set.

**ChrgMinTemp, DischrgMaxTemp, ChrgMaxTemp:** If the measured temperature is less than **ChrgMinTemp**, the ChargingCurrent is set to **ChrgCurrOff** and the ChargingVoltage is set to **ChrgVolt** to communicate to the charger that the non-charging state of current and voltage should be given. When measured temperature is greater than **ChrgMaxTemp** and the system is charging, or greater than **DischrgMaxTemp** and the system is discharging, then ChargingCurrent is set to **ChrgCurrOff** and the ChargingVoltage is set to **ChrgVoltOff** also. Otherwise, ChargingCurrent = **ChrgCurr** and ChargingVoltage = **ChrgVolt**.

# PS501-0901

## 6.0 GPIO CONFIGURATION

GPIOs can be set up to act as inputs or outputs that are based on conditions involving SBData parameters, or GPIO levels, compared to constants. This powerful programming model allows for customizing GPIO to set on any possible fuel gauge conditions and reset on any other possible fuel gauge conditions in any groupings.

**TABLE 6-1: GPIO CONFIGURATIONS**

Name	Length	Definition
GPIOSTATE	2	Initialized default state (positive logic)
GPIODIRECTION	2	Initialized direction: 1 = input 0 = output
GPIOCONFIG	2	GPIO configuration <u>Bit 8:</u> 1 = Pull-ups/downs disabled 0 = Pull-downs enabled <u>Bits 7-0:</u> If input: 1 = Pulled down 0 = Pulled up If output: 1 = LED drive (GPIO0-7 only) 0 = Standard logic
GIOPOLARITY	2	“Polarity” mask applied to invert positive logic

GPIOs configured above as standard logic output can be programmed to activate or reset in response to any group of fuel gauge conditions. Each “condition” is defined by 4 bytes.

**TABLE 6-2: GPIO CONDITIONS**

Byte	Condition	Definition
Byte 1	Flags	bit 7: ‘1’ signifies last condition in group bit 4: Combination function (1: AND, 0: OR) bit 3: Signed (‘1’) or unsigned (‘0’) bits 2-0: Comparison function (0 : >, 1 : <, 2 : =, 3 : AND, 4 : NOR)
Byte 2	Condition selection	x00-x3F – SBData command code x40 – State flags x41 – GPIO flags x42 – N/A x43 – N/A x44 – N/A x45 – Misc. flags
Byte 3 Byte 4	Condition threshold	Constant

Each condition in the table is processed by applying a “comparison function” to the selected data (“condition selection”) and the given constant (“condition threshold”). The result of this operation (“true” or “false”) from each condition in the group is combined as dictated by the “AND-OR” “combination function” bit in the flag byte. Because the “AND” function has precedence over the “OR”, processing the CG can be described as OR’ing subgroups of ANDs (see Example 6-1 below).

One 8-bit timer (clocked at 500 msec) is associated with all 16 CSF(s). The timer compared to its threshold is an implied “AND” term to the CG (i.e., if processing

of the CG to set the CSF results in “true”, the timer is incremented and if timer  $\geq$  threshold, the SF is set; otherwise, the SF is not set even though the GC is satisfied). If processing of the CG to set the CSF results in “false”, the timer is set to zero. The timer is not allowed to increment past the threshold.

The conditions in the order they are stored in memory will build the activation equation until bit 7 of byte 1 is set, signifying the last condition of the group. At that point, the next group of conditions is the Reset equation. When the next to last condition bit is set, a new activation group begins.

## EXAMPLE 6-1: CONDITION GROUPS

### Example Condition Group:

$(VPACK < 9000) .AND. (CURR > 100) .OR. (TEMP > 60) .AND. (CURR > 200)$

because of precedence, the equation would be interpreted:

$((VPACK < 9000) .AND. (CURR > 100)) .OR. ((TEMP > 60) .AND. (CURR > 200))$

### Example Reset Condition Group:

$(VPACK > 9000) OR (CURR = 200)$

**TABLE 6-3: CONDITIONS FOR EXAMPLE 6-1**

Condition	Byte 1	Byte 2	Byte 3, 4	Description
1	x01	x42	x0C80	OR VPACK < 9000
2	x10	x0A	x0064	AND CURR > 100
3	x00	x08	x0D02	OR TEMP > 60°C (3330 degrees K * 10)
4	x80	x0A	x00C8	AND CURR > 200 (last condition bit set)
1	x00	x42	x0C80	OR VPACK > 9000
2	x82	x0A	x00C8	OR CURR = 200 (last condition bit set)

**TABLE 6-4: PARAMETERS**

Name	Length	Description
SAFE_GPIO_MASK_00	2	Mask applied to the CSF, if $\langle \rangle$ 0, GPIO is set
SAFE_GPIO_MASK_01	2	Mask applied to the CSF, if $\langle \rangle$ 0, GPIO is set
SAFE_GPIO_MASK_02	2	Mask applied to the CSF, if $\langle \rangle$ 0, GPIO is set
SAFE_GPIO_MASK_03	2	Mask applied to the CSF, if $\langle \rangle$ 0, GPIO is set
SAFE_GPIO_MASK_04	2	Mask applied to the CSF, if $\langle \rangle$ 0, GPIO is set
SAFE_GPIO_MASK_05	2	Mask applied to the CSF, if $\langle \rangle$ 0, GPIO is set
SAFE_GPIO_MASK_06	2	Mask applied to the CSF, if $\langle \rangle$ 0, GPIO is set
SAFE_GPIO_MASK_07	2	Mask applied to the CSF, if $\langle \rangle$ 0, GPIO is set
SAFE_GPIO_MASK_08	2	Mask applied to the CSF, if $\langle \rangle$ 0, GPIO is set
SAFE_GPIO_MASK_09	2	Mask applied to the CSF, if $\langle \rangle$ 0, GPIO is set
SAFE_GPIO_MASK_10	2	Mask applied to the CSF, if $\langle \rangle$ 0, GPIO is set
SAFE_GPIO_MASK_11	2	Mask applied to the CSF, if $\langle \rangle$ 0, GPIO is set

# PS501-0901

**TABLE 6-4: PARAMETERS (CONTINUED)**

Name	Length	Description
SAFE_TIMER_LIMIT_0	1	Timer threshold/limit (500 msec tics)
SAFE_TIMER_LIMIT_1	1	
SAFE_TIMER_LIMIT_2	1	
SAFE_TIMER_LIMIT_3	1	
SAFE_TIMER_LIMIT_4	1	
SAFE_TIMER_LIMIT_5	1	
SAFE_TIMER_LIMIT_6	1	
SAFE_TIMER_LIMIT_7	1	
SAFE_TIMER_LIMIT_8	1	
SAFE_TIMER_LIMIT_9	1	
SAFE_TIMER_LIMIT_10	1	
SAFE_TIMER_LIMIT_11	1	
SAFE_TIMER_LIMIT_12	1	
SAFE_TIMER_LIMIT_13	1	
SAFE_TIMER_LIMIT_14	1	
SAFE_TIMER_LIMIT_15	1	
SAFE_FLAG_COUNT	1	Number of CSF(s) to process, 0-16 (there must be 2 condition groups (CGs) per CSF)
SAFE_CONDITION	4	Condition (start of table)
...	4	Condition
SAFE_CONDITION	4	Condition (end of table)

## 6.1 LED Parameters

When configured as LED drivers, the following parameters determine the State-Of-Charge at which each LED will turn on.

**TABLE 6-5: LED PARAMETERS**

Name	Length	Definition
LED_MASK	1	Mask defining GPIO(s) used for LED display(s) (1 = LED).
LED_VALUE_0	1	GPIO 0 SOC value (SOC >= LED_VALUE, LED = on).
LED_VALUE_1	1	GPIO 1 SOC value (SOC >= LED_VALUE, LED = on).
LED_VALUE_2	1	GPIO 2 SOC value (SOC >= LED_VALUE, LED = on).
LED_VALUE_3	1	GPIO 3 SOC value (SOC >= LED_VALUE, LED = on).
LED_VALUE_4	1	GPIO 4 SOC value (SOC >= LED_VALUE, LED = on).
LED_VALUE_5	1	GPIO 5 SOC value (SOC >= LED_VALUE, LED = on).
LED_VALUE_6	1	GPIO 6 SOC value (SOC >= LED_VALUE, LED = on).
LED_VALUE_7	1	GPIO 7 SOC value (SOC >= LED_VALUE, LED = on).
LED_ICHG	2	Current threshold for LED display.
LED_DUTYCYCLE	1	Duty cycle of LED drivers.
GPIO_SWITCHMASK	2	Mask for switch input(s). If switch is active-high, all bits are '0' except switch pin. If switch is active-low, all bits are '1' except switch pin.
LED_DISPLAY_TIME	1	Number of 500 ms periods LEDs are lit after switch press.

## 7.0 SMBus/SBData INTERFACE

The PS501-0901 uses a two-pin System Management Bus (SMBus) protocol to communicate to the host. One pin is the clock and one is the data. The SMBus port responds to all commands in the Smart Battery Data specification (SBData). To receive information about the battery, the host sends the appropriate commands to the SMBus port. Certain alarms, warnings and charging information may be sent to the host by the PS501-0901 automatically. The SMBus protocol is explained in this chapter. The SBData command set is summarized in Table 7-1.

The PS501-0901 SMBus communications port is fully compliant with the System Management Bus specification, version 1.1 and supports all previous and new requirements, including bus time-outs (both slave and master), multi-master arbitration, collision detection/recovery and PEC (CRC-8) error checking. The SMBus port serves as a slave for both read and write functions, as well as a master for write word functions. SMBus slave protocols supported include read word, write word, read block and write block, all with or without PEC (CRC-8) error correction. Master mode supports write word protocols. The PS501-0901 meets and exceeds the Smart Battery Data specification, version 1.1/1.1a requirements. The PS501-0901 is compliant with System Management Bus specification 1.0.

The PS501-0901 fully implements the Smart Battery Data (SBData) specification v1.1. The SBData specification defines the interface and data reporting mechanism for an SBS compliant Smart Battery. It defines a consistent set of battery data to be used by a power management system to improve battery life and system run time, while providing the user with accurate information. This is accomplished by incorporating fixed, measured, calculated and predicted values, along with charging and alarm messages, with a simple communications mechanism between a host system, Smart Batteries and a Smart Charger.

The PS501-0901 provides full implementation of the SBData set with complete execution of all the data functions, including subfunctions and control bits and flags, compliance to the accuracy and granularity associated with particular data values and proper SMBus protocols and timing.

# PS501-0901

## 7.1 SBData Function Description

The subsections following Table 7-1 document the detailed operation of all of the individual SBData commands.

**TABLE 7-1: SMART BATTERY DATA FUNCTIONS**

SBData Function Name	Command Code	Access	Parameter Reference	Units
<u>ManufacturerAccess-Write</u>	0x00	R/W	<b>PW1, PW2</b>	Code
<u>ManufacturerAccess-Read</u>	0x00	R/W	Chip version	Code
<u>RemainingCapacityAlarm</u>	0x01	R/W	<b>RemCapAI</b>	mAh or 10 mWh
<u>RemainingTimeAlarm</u>	0x02	R/W	<b>RemTimeAI</b>	Minutes
<u>BatteryMode</u>	0x03	R/W		Bit code
<u>AtRate</u>	0x04	Read		mAh or 10 mWh
<u>AtRateTimeToFull</u>	0x05	Read		Minutes
<u>AtRateTimeToEmpty</u>	0x06	Read		Minutes
<u>AtRateOK</u>	0x07	Read		Binary 0/1 (LSB)
<u>Temperature</u>	0x08	Read		0.1°K
<u>Voltage</u>	0x09	Read		mV
<u>Current</u>	0x0a	Read		mA
<u>AverageCurrent</u>	0x0b	Read		mA
<u>MaxError</u>	0x0c	Read		%
<u>RelativeStateOfCharge</u>	0x0d	Read		%
<u>AbsoluteStateOfCharge</u>	0x0e	Read		%
<u>RemainingCapacity</u>	0x0f	Read		mAh or 10 mWh
<u>FullChargeCapacity</u>	0x10	Read		mAh or 10 mWh
<u>RunTimeToEmpty</u>	0x11	Read		Minutes
<u>AverageTimeToEmpty</u>	0x12	Read		Minutes
<u>AverageTimeToFull</u>	0x13	Read		Minutes
<u>ChargingCurrent</u>	0x14	Read	<b>ChrgCurr</b> or <b>ChrgCurrOff</b>	mA
<u>ChargingVoltage</u>	0x15	Read	<b>ChrgVolt</b> or <b>ChrgVoltOff</b>	mV
<u>BatteryStatus</u>	0x16	Read	<b>BatStatus</b>	Bit code
<u>CycleCount</u>	0x17	Read	<b>Cycles</b>	Integer
<u>DesignCapacity</u>	0x18	Read	<b>DesignCapacity</b>	mAh or 10 mWh
<u>DesignVoltage</u>	0x19	Read	<b>DesignVPack</b>	mV
<u>SpecificationInfo</u>	0x1a	Read	<b>SBDataVersion</b>	Coded
<u>ManufactureDate</u>	0x1b	Read	<b>Date</b>	Coded
<u>SerialNumber</u>	0x1c	Read	<b>SerialNumber</b>	Not specified
<u>FirmwareInfo<sup>(1)</sup></u>	0x1d	Read	FW Version and <b>PW1, PW2</b>	Coded
<u>ManufacturerName</u>	0x20	Read	<b>MFGName</b>	ASCII text string
<u>DeviceName</u>	0x21	Read	<b>DeviceName</b>	ASCII text string
<u>DeviceChemistry</u>	0x22	Read	<b>Chemistry</b>	ASCII text string
<u>ManufacturerData</u>	0x23	Read	<b>MFGData</b>	HEX string
<u>OptionalMfgFunction4</u>	0x3c	Read		
<u>OptionalMfgFunction3</u>	0x3d	Read		
<u>OptionalMfgFunction2</u>	0x3e	Read		
<u>OptionalMfgFunction1</u>	0x3f	Read		
<u>OptionalMfgFunction5</u>	0x2f	Read	GPIO pin status	Bit-coded data

**Note 1:** Reports internal software version when read, opens EEPROM (and selected other values) for programming when written.

## 7.1.1 ManufacturerAccess (0x00)

Reports internal software version when read, opens EEPROM for programming when written with the password.

## 7.1.2 RemainingCapacityAlarm (0x01)

Sets or reads the low capacity alarm value. Whenever the remaining capacity falls below the low capacity alarm value, the Smart Battery sends alarm warning messages to the SMBus host with the REMAINING\_CAPACITY\_ALARM bit set. A low capacity alarm value of '0' disables this alarm.

## 7.1.3 RemainingTimeAlarm (0x02)

Sets or reads the remaining time alarm value. Whenever the AverageTimeToEmpty falls below the remaining time value, the Smart Battery sends alarm warning messages to the SMBus host with the REMAINING\_TIME\_ALARM bit set. A remaining time value of '0' disables this alarm.

## 7.1.4 BatteryMode (0x03)

This function selects the various battery operational modes and reports the battery's capabilities, modes and condition.

### **Bit 0:** INTERNAL\_CHARGE\_CONTROLLER

Bit set indicates that the battery pack contains its own internal charge controller. When the bit is set, this optional function is supported and the CHARGE\_CONTROLLER\_ENABLED bit will be activated.

### **Bit 1:** PRIMARY\_BATTERY\_SUPPORT

Bit set indicates that the battery pack has the ability to act as either the primary or secondary battery in a system. When the bit is set, this optional function is supported and the PRIMARY\_BATTERY bit will be activated.

### **Bit 2-6:** Reserved

### **Bit 7:** CONDITION\_FLAG

Bit set indicates that the battery is requesting a conditioning cycle. This typically will consist of a full charge to full discharge, back to full charge of the pack. The battery will clear this flag after it detects that a conditioning cycle has been completed.

### **Bit 8:** CHARGE\_CONTROLLER\_ENABLED

Bit is set to enable the battery pack's internal charge controller. When this bit is cleared, the internal charge controller is disabled (default). This bit is active only when the INTERNAL\_CHARGE\_CONTROLLER bit is set.

### **Bit 9:** PRIMARY\_BATTERY

Bit is set to enable a battery to operate as the primary battery in a system. When this bit is cleared, the battery operates in a secondary role (default). This bit is active only when the PRIMARY\_BATTERY\_SUPPORT bit is set.

### **Bit 10-13:** Reserved

### **Bit 14:** CHARGER\_MODE

Enables or disables the Smart Battery's transmission of ChargingCurrent and ChargingVoltage messages to the Smart Battery Charger. When set, the Smart Battery will not transmit ChargingCurrent and ChargingVoltage values to the charger. When cleared, the Smart Battery will transmit the ChargingCurrent and ChargingVoltage values to the charger when charging is desired.

### **Bit 15:** CAPACITY\_MODE

Indicates if capacity information will be reported in mA/mAh or 10 mW/10 mWh. When set, the capacity information will be reported in 10 mW/10 mWh. When cleared, the capacity information will be reported in mA/mAh.

## 7.1.5 AtRate (0x04)

AtRate is a value of current or power that is used by three other functions: AtRateTimeToFull, AtRateTimeToEmpty and AtRateOK:

- AtRateTimeToFull returns the predicted time to full charge at the AtRate value of charge current.
- AtRateTimeToEmpty function returns the predicted operating time at the AtRate value of discharge current.
- AtRateOK function returns a Boolean value that predicts the battery's ability to supply the AtRate value of additional discharge current for 10 seconds.

## 7.1.6 AtRateTimeToFull (0x05)

Returns the predicted remaining time to fully charge the battery at the AtRate value (mA). The AtRateTimeToFull function is part of a two-function call set used to determine the predicted remaining charge time at the AtRate value in mA. It will be used immediately after the SMBus host sets the AtRate value.

## 7.1.7 AtRateTimeToEmpty (0x06)

Returns the predicted remaining operating time if the battery is discharged at the AtRate value. The AtRateTimeToEmpty function is part of a two-function call set used to determine the remaining operating time at the AtRate value. It will be used immediately after the SMBus host sets the AtRate value.

# PS501-0901

---

## 7.1.8 AtRateOK (0x07)

Returns a Boolean value that indicates whether or not the battery can deliver the AtRate value of additional energy for 10 seconds (Boolean). If the AtRate value is zero or positive, the AtRateOK function will always return true. The AtRateOK function is part of a two-function call set used by power management systems to determine if the battery can safely supply enough energy for an additional load. It will be used immediately after the SMBus host sets the AtRate value.

## 7.1.9 Temperature (0x08)

Returns the cell pack's internal temperature in units of 0.1K.

## 7.1.10 Voltage (0x09)

Returns the pack voltage (mV).

## 7.1.11 Current (0x0a)

Returns the current being supplied (or accepted) through the battery's terminals (mA).

## 7.1.12 AverageCurrent (0x0b)

Returns a one-minute rolling average based on at least 60 samples of the current being supplied (or accepted) through the battery's terminals (mA).

## 7.1.13 MaxError (0x0c)

Returns the expected margin of error (%) in the State-Of-Charge calculation. For example, when MaxError returns 10% and RelativeStateOfCharge returns 50%, the RelativeStateOfCharge is actually between 50% and 60%. The MaxError of a battery is expected to increase until the Smart Battery identifies a condition that will give it higher confidence in its own accuracy. For example, when a Smart Battery senses that it has been fully charged from a fully discharged state, it may use that information to reset or partially reset MaxError. The Smart Battery can signal when MaxError has become too high by setting the CONDITION\_FLAG bit in BatteryMode.

## 7.1.14 RelativeStateOfCharge (0x0d)

Returns the predicted remaining battery capacity expressed as a percentage of FullChargeCapacity (%).

## 7.1.15 AbsoluteStateOfCharge (0x0e)

Returns the predicted remaining battery capacity expressed as a percentage of DesignCapacity (%). Note that AbsoluteStateOfCharge can return values greater than 100%.

## 7.1.16 RemainingCapacity (0x0f)

Returns the predicted remaining battery capacity. The RemainingCapacity value is expressed in either current (mAh) or power (10 mWh), depending on the setting of the BatteryMode's CAPACITY\_MODE bit.

## 7.1.17 FullChargeCapacity (0x10)

Returns the predicted pack capacity when it is fully charged. It is based on either current or power, depending on the setting of the BatteryMode's CAPACITY\_MODE bit.

## 7.1.18 RunTimeToEmpty (0x11)

Returns the predicted remaining battery life at the present rate of discharge (minutes). The RunTimeToEmpty value is calculated based on either current or power, depending on the setting of the BatteryMode's CAPACITY\_MODE bit. This is an important distinction because use of the wrong Calculation mode may result in inaccurate return values.

## 7.1.19 AverageTimeToEmpty (0x12)

Returns a one-minute rolling average of the predicted remaining battery life (minutes). The AverageTimeToEmpty value is calculated based on either current or power, depending on the setting of the BatteryMode's CAPACITY\_MODE bit. This is an important distinction because use of the wrong Calculation mode may result in inaccurate return values.

## 7.1.20 AverageTimeToFull (0x13)

Returns a one-minute rolling average of the predicted remaining time until the Smart Battery reaches full charge (minutes).

## 7.1.21 ChargingCurrent (0x14)

Sets the maximum charging current for the Smart Battery Charger to charge the battery. This can be written to the Smart Battery Charger from the Smart Battery or requested by the Smart Battery Charger from the battery.

## 7.1.22 ChargingVoltage (0x15)

Sets the maximum charging voltage for the Smart Battery Charger to charge the battery. This can be written to the Smart Battery Charger from the Smart Battery or requested by the Smart Battery Charger from the battery.

## 7.1.23 BatteryStatus (0x16)

Returns the Smart Battery's status word (flags). Some of the BatteryStatus flags, like REMAINING\_CAPACITY\_ALARM and REMAINING\_TIME\_ALARM, are calculated based on either current or power, depending on the setting of the BatteryMode's CAPACITY\_MODE bit. This is important because use of the wrong Calculation mode may result in an inaccurate alarm. The BatteryStatus function is used by the power management system to get alarm and status bits, as well as error codes, from the Smart Battery. This is basically the same information returned by the SBData AlarmWarning function, except that the AlarmWarning function sets the error code bits all high before sending the data. Also, information broadcasting is disabled in the PS501-0901.

### Battery Status Bits:

- bit 15:** OVER\_CHARGED\_ALARM
- bit 14:** TERMINATE\_CHARGE\_ALARM
- bit 13:** Reserved
- bit 12:** OVER\_TEMP\_ALARM
- bit 11:** TERMINATE\_DISCHARGE\_ALARM
- bit 10:** Reserved
- bit 9:** REMAINING\_CAPACITY\_ALARM
- bit 8:** REMAINING\_TIME\_ALARM
- bit 7:** INITIALIZED
- bit 6:** DISCHARGING
- bit 5:** FULLY\_CHARGED
- bit 4:** FULLY\_DISCHARGED

The host system assumes responsibility for detecting and responding to Smart Battery alarms by reading the BatteryStatus to determine if any of the alarm bit flags are set. At a minimum, this requires the system to poll the Smart Battery BatteryStatus every 10 seconds at all times the SMBus is active.

## 7.1.24 CycleCount (0x17)

CycleCount is updated to keep track of the total usage of the battery. CycleCount is increased whenever an amount of charge has been delivered to, or removed from the battery, equivalent to the full capacity.

## 7.1.25 DesignCapacity (0x18)

Returns the theoretical capacity of a new pack. The DesignCapacity value is expressed in either current or power, depending on the setting of the BatteryMode's CAPACITY\_MODE bit.

## 7.1.26 DesignVoltage (0x19)

Returns the theoretical voltage of a new pack (mV).

## 7.1.27 SpecificationInfo (0x1a)

Returns the version number of the Smart Battery specification the battery pack supports.

## 7.1.28 ManufactureDate (0x1b)

This function returns the date the cell pack was manufactured in a packed integer. The date is packed in the following fashion: (year-1980) \* 512 + month \* 32 + day.

## 7.1.29 SerialNumber (0x1c)

This function is used to return a serial number. This number, when combined with the ManufacturerName, the DeviceName and the ManufactureDate, will uniquely identify the battery.

## 7.1.30 ManufacturerName (0x20)

This function returns a character array containing the battery manufacturer's name.

## 7.1.31 DeviceName (0x21)

This function returns a character string that contains the battery's name.

## 7.1.32 DeviceChemistry (0x22)

This function returns a character string that contains the battery's chemistry. For example, if the DeviceChemistry function returns "NiMH", the battery pack would contain nickel metal hydride cells. The following is a partial list of chemistries and their expected abbreviations. These abbreviations are not case sensitive.

- Lead Acid: PbAc
- Lithium Ion: LiON
- Nickel Cadmium: NiCd
- Nickel Metal Hydride: NiMH
- Nickel Zinc: NiZn
- Rechargeable Alkaline-Manganese: RAM
- Zinc Air: ZnAr

## 7.1.33 ManufacturerData (0x23)

This function allows access to the manufacturer data contained in the battery (data).

## 7.1.34 OptionalMfgFunction

The PS501-0901 does not implement this function.

# PS501-0901

**TABLE 7-2: PS501-0901 ALARMS AND STATUS SUMMARY**

Battery Status	Set Condition	Clear Condition
FULLY_CHARGED bit	Set at End-Of-Charge Condition: Charge FET off AND Any VC(x) input > 4.175V AND IAVG < EOC_IAVG for <b>ChrgCntrlTimer</b> number of consecutive counts	<u>RelativeStateOfCharge</u> ( ) < <b>ClrFullyChrg</b> (default RSOC = 80%)
OVER_CHARGED_ALARM bit	Valid EOC	VPACK < Reset <b>TCAVolt</b>
TERMINATE_CHARGE_ALARM bit	Charging Temperature ( ) > <b>ChrgMaxTemp</b> (default 60°C) OR FULLY_CHARGED bit = 1	VPACK < Reset <b>TCAVolt</b> AND <u>Temperature</u> ( ) < <b>ChrgRecTemp</b> = AND <u>Current</u> ( ) = < 0
OVER_TEMP_ALARM bit	Temperature ( ) > <b>HighTempAI</b> (default 55°C)	<u>Temperature</u> ( ) < <b>HighTempAI</b>
TERMINATE_DISCHARGE_ALARM bit	Primary Method: VPACK < <b>VPackEOD1</b> (per Look-up Table) AND Above condition continues for near <b>EOD1Recheck</b> time Secondary Method: VPACK < <b>VPackEOD2</b> AND Above condition continues for <b>EOD2Recheck</b> time	Primary Method: All VPACK > <b>VPackEOD1</b> OR <u>Current</u> ( ) > 0  Secondary Method: All VPACK > <b>VPackEOD2</b> OR <u>Current</u> ( ) > 0
REMAINING_CAPACITY_ALARM bit	<u>RemainingCapacity</u> ( ) < <u>RemainingCapacityAlarm</u> ( )	<u>RemainingCapacity</u> ( ) > <u>RemainingCapacityAlarm</u> ( )
REMAINING_TIME_ALARM bit	<u>AverageTimeToEmpty</u> ( ) < <u>RemainingTimeAlarm</u> ( )	<u>AverageTimeToEmpty</u> ( ) > <u>RemainingTimeAlarm</u> ( )
FULLY_DISCHARGED bit	<u>RemainingCapacity</u> ( ) = 0	<u>RelativeStateOfCharge</u> ( ) > <b>ClrFullyDischrg</b> (default RSOC = 20%)

## 8.0 PARAMETER SETUP

This section documents all of the programmable parameters that are resident in memory. It includes parameters that are common to the standard PS501-0901 parameter set. The parameter set is organized into the following functional groups:

1. Configuration
2. Calibration
3. Safety
4. Charge and Discharge
5. Capacity

**TABLE 8-1: CONFIGURATION**

Parameter Name	# Bytes	Lower Limit	Upper Limit	Typical Value	Operational Description																		
<b>Cells</b>	1	0	255	6	Number of series cells in the battery pack.																		
<b>Date</b>	2	0	0xFFFF	0x2B7E	SBDData value for <u>ManufactureDate</u> . The date of manufacture of the battery pack can be programmed here and retrieved with the SBDData <u>ManufactureDate</u> command. Coding: Date = (Year-1980) x 512 + Month x 32 + Day																		
<b>SerialNumber</b>	2	0	65535	1	SBDData value for <u>SerialNumber</u> . The serial number of the battery pack can be programmed here and retrieved with the SBDData <u>SerialNumber</u> command.																		
<b>MFGData</b>	4	–	–	0x0	SBS string for <u>ManufacturerData</u> .																		
<b>PackResistance</b>	2	0	65535	65	Resistance of pack.																		
<b>NullCurr</b>	1	0	255	3	A zero zone control is built into the PS501-0901 so that any small inaccuracy doesn't actually drain the fuel gauge, when in fact, the current is zero. For this reason, current less than <b>NullCurr</b> mA in either direction will be measured as zero.																		
<b>Flags1</b>	1	0	255	b00100110	Bit coded as follows: <table border="1" style="font-size: small;"> <thead> <tr> <th>Bit</th> <th>Function</th> </tr> </thead> <tbody> <tr> <td>7</td> <td>Enable precharge max current check</td> </tr> <tr> <td>6</td> <td>Hold charge current = 0 until next discharge</td> </tr> <tr> <td>5</td> <td>Int/Ext temperature</td> </tr> <tr> <td>4</td> <td>Disable Sleep in main Idle mode</td> </tr> <tr> <td>3</td> <td>Require null current for low-voltage Sleep</td> </tr> <tr> <td>2</td> <td>Disable safety GPIO</td> </tr> <tr> <td>1</td> <td>Enable pack resistance</td> </tr> <tr> <td>0</td> <td>Enable Sample mode detect</td> </tr> </tbody> </table>	Bit	Function	7	Enable precharge max current check	6	Hold charge current = 0 until next discharge	5	Int/Ext temperature	4	Disable Sleep in main Idle mode	3	Require null current for low-voltage Sleep	2	Disable safety GPIO	1	Enable pack resistance	0	Enable Sample mode detect
Bit	Function																						
7	Enable precharge max current check																						
6	Hold charge current = 0 until next discharge																						
5	Int/Ext temperature																						
4	Disable Sleep in main Idle mode																						
3	Require null current for low-voltage Sleep																						
2	Disable safety GPIO																						
1	Enable pack resistance																						
0	Enable Sample mode detect																						
<b>LowCurrError</b>	1	0	255	0	Current offset for error calculation. Since the error of the A/D converter is proportional to the level of current it is measuring, the error term can be too low when the current is very low. For this reason, the <b>LowCurrError</b> will compensate the error term for low currents. <b>LowCurrError</b> milliamps are added to the current when factoring in the error. Thus, the error is: Error = (Current + <b>LowCurrError</b> ) * <b>CurrError</b> .																		
<b>CurrError</b>	1	0	255	0	Current measurement error. This is the error due to the accuracy of the A/D converter to measure and integrate the current, 255 = 100%.																		
<b>StableCurr</b>	1	0	255	50	EOC trigger current deviation level. In order to prevent current spikes from causing a premature taper current trigger, the average current and the instantaneous current must be within <b>StableCurr</b> of each other for the End-Of-Charge to trigger.																		
<b>RelearnLimit</b>	1	0	255	205	The maximum relearn limit. The maximum percentage that the <b>FullCapacity</b> can change after a learning cycle, where 255 = 100%.																		

# PS501-0901

TABLE 8-1: CONFIGURATION (CONTINUED)

Parameter Name	# Bytes	Lower Limit	Upper Limit	Typical Value	Operational Description																		
DesignVPack	2	0	65535	9000	SBDData value for <u>DesignVoltage</u> .																		
PW1	2	0	65535	AA4D	First password for the battery pack lock.																		
PW2	2	0	65535	D4AA	Second password for the battery pack lock.																		
SpecInfo	2	0	0xFFFF	0x21	<b>SpecInfo</b> refers to Smart Battery specification version 1.1.																		
BatStatus	1	0	255	b01000000	SBDData register for <u>BatteryStatus</u> .																		
Cycles	2	0	65535	0	SBDData register for <u>CycleCount</u> . <b>Cycles</b> is updated to keep track of the total usage of the battery. A cycle is the amount of discharge approximately equal to the value of <u>DesignCapacity</u> . For a 4000 mAh battery, <b>Cycles</b> is increased every time 4000 mAh is discharged from the battery.																		
SMBMstrBaud	1	0	127	1	Master broadcast baud rate (512 kHz/4)/( <b>SMBMstrBaud</b> + 1).																		
ConfigLED	1	0	255	b10000010	Bit coded as follows: <table border="0"> <tr> <td><u>Bit</u></td> <td><u>Function</u></td> </tr> <tr> <td>7</td> <td>Disable Master mode</td> </tr> <tr> <td>6</td> <td>Unused</td> </tr> <tr> <td>5</td> <td>Enable fast LED time base</td> </tr> <tr> <td>4</td> <td>LED display while charging</td> </tr> <tr> <td>3</td> <td>Display the most significant LED only</td> </tr> <tr> <td>2</td> <td>LED using absolute SOC, else relative SOC</td> </tr> <tr> <td>1</td> <td>Flash LEDs on remaining time or remaining cap alarm</td> </tr> <tr> <td>0</td> <td>Flash LEDs while charging</td> </tr> </table>	<u>Bit</u>	<u>Function</u>	7	Disable Master mode	6	Unused	5	Enable fast LED time base	4	LED display while charging	3	Display the most significant LED only	2	LED using absolute SOC, else relative SOC	1	Flash LEDs on remaining time or remaining cap alarm	0	Flash LEDs while charging
<u>Bit</u>	<u>Function</u>																						
7	Disable Master mode																						
6	Unused																						
5	Enable fast LED time base																						
4	LED display while charging																						
3	Display the most significant LED only																						
2	LED using absolute SOC, else relative SOC																						
1	Flash LEDs on remaining time or remaining cap alarm																						
0	Flash LEDs while charging																						
SMBChrgAddr	1	0x0	0xFF	0x12	Broadcast charger address.																		
SMBHostAddr	1	0x0	0xFF	0x10	Broadcast host address.																		
NChrgBroadcast	1	0	255	20	Frequency of charging condition broadcasts.																		
SMBAlrmInterval	1	0	255	120	Delay between alarm broadcasts, units 0.5 seconds.																		
Flags2	1	0	255	0b1000000 0	Bit coded as follows: <table border="0"> <tr> <td><u>Bit</u></td> <td><u>Function</u></td> </tr> <tr> <td>7</td> <td>1 = Compensate remcap only on discharge</td> </tr> <tr> <td>6</td> <td>Internal test bit (CJ)</td> </tr> <tr> <td>5</td> <td>Internal test bit (CL)</td> </tr> <tr> <td>4</td> <td>1 = Compensate remcap on null current</td> </tr> <tr> <td>3</td> <td>1 = Disable charge acceptance</td> </tr> <tr> <td>2</td> <td>Unused</td> </tr> <tr> <td>1</td> <td>Unused</td> </tr> <tr> <td>0</td> <td>Unused</td> </tr> </table>	<u>Bit</u>	<u>Function</u>	7	1 = Compensate remcap only on discharge	6	Internal test bit (CJ)	5	Internal test bit (CL)	4	1 = Compensate remcap on null current	3	1 = Disable charge acceptance	2	Unused	1	Unused	0	Unused
<u>Bit</u>	<u>Function</u>																						
7	1 = Compensate remcap only on discharge																						
6	Internal test bit (CJ)																						
5	Internal test bit (CL)																						
4	1 = Compensate remcap on null current																						
3	1 = Disable charge acceptance																						
2	Unused																						
1	Unused																						
0	Unused																						
PwrConsumption	2	0	65535	36	Current consumption of the battery module. This is the average current that the battery module typically draws from the battery (255 = 1 mA).																		
SelfDischrgErr	1	0	255	1	Self-discharge error. This is the error inherent in the ability of the self-discharge look-up tables to meet actual battery characteristics, 255 = 100%.																		
SampleModeRecheck	1	0	255	6	Number of operating cycles needed with current < <b>SampleLimit</b> before entering Sample mode.																		
SampleLimit	2	0	65535	15	Value used to determine the current threshold for entry/exit for Sample and Run modes in mA.																		
AOMInt	1	0	255	60	The frequency of the auto-offset calibration cycle.																		

**TABLE 8-1: CONFIGURATION (CONTINUED)**

Parameter Name	# Bytes	Lower Limit	Upper Limit	Typical Value	Operational Description
<b>AgeFactor</b>	1	0	255	0	Scale factor for EOD voltage due to aging.
<b>PwrUpTimer</b>	1	0	255	4	Time during which GPIO are inactive after first power-up.
<b>NPermLogCnt</b>	1	0	255	0	Counter for logging Faults.
<b>NPermLogReg</b>	1	0	255	0	Register for logging Faults.
<b>RelnitGPIO</b>	2	0	65535	0	Register for resetting all GPIO during testing.
<b>GPiODelayFlags</b>	2	0	65535	0	Positive logic change of GPIO is delayed when upper byte is set. Lower byte maps to GPIO.
<b>GPiODelayMS</b>	1	0	255	0	GPIO delay in milliseconds when <b>GPiODelayFlags</b> has the delay enabled.
<b>MFGName</b>	10	–	–	Microchip	SBS string for <u>ManufacturerName</u> . Can be any ASCII string, typically the name of the battery pack manufacturer. Length of string is defined by <u>MFGNameLength</u> .
<b>DeviceName</b>	8	–	–	PS501-0901	SBData value for <u>DeviceName</u> . Can be any ASCII string. Length defined by <u>DeviceNameLength</u> . The battery circuit device name can be programmed here and retrieved with the SBData <u>DeviceName</u> command.
<b>Chemistry</b>	8	–	–	NIMH	SBS data for <u>DeviceChemistry</u> . Can be any ASCII string. Length defined by <u>ChemistryLength</u> . The <b>Chemistry</b> name can be programmed here and retrieved with the SBData <u>DeviceChemistry</u> command.
<b>ParamVersion</b>	1	0	255	0	EEPROM version control number.
<b>KeyByte</b>	1	0x0	0xFF	0xDA	EE <b>KeyByte</b> must be 0xDA before P5 will exit Bootloader mode.

# PS501-0901

TABLE 8-2: CALIBRATION

Parameter Name	# Bytes	Lower Limit	Upper Limit	Typical Value	Operational Description																						
Config1	1	0x0	0xFF	0x69	Bootload configuration.																						
OSCTrim	1	0	255	200	RC oscillator trimming.																						
BGCal	1	0	255	11	Band gap voltage calibration factor.																						
RefCal	1	0	255	19	Reference voltage calibration factor.																						
CFCurr	2	0	65535	6844	Correction Factor for Current. Adjusts the scaling of the sense resistor current measurements. Used to calibrate the measurement of current at the RSHP and RSHN input pins. This is set for the size of the current sense resistor.																						
COCurr	1	-128	127	-12	Correction Offset for Current. This is the value the A/D reads when zero current is flowing through the sense resistor.																						
COD	1	-128	127	-12	Correction Offset Deviation. Offset value for the auto-zero calibration of the current readings. $SBDData_{Current} [mA] = (I_{A/D} - COCurr - COD) \times CFCurr / 16384$ Calibration: $CFCurr = ((Ammeter [mA] \times 16384) - 8192) / (Current - I_{A/D} \text{ at OCV})$																						
CFTempE	2	0	65535	1300	Correction Factor for Temperature. Adjusts the scaling of temperature measured across an external thermistor at the VNTC input pin.																						
COTempE	1	-128	127	-2	Correction Offset for Temperature. Offset = 0 used for temperature measurement using internal temperature sensor.																						
CFTempl	2	0	65535	23800	Correction Factor for Temperature. Adjusts the scaling of temperature measured from the internal temperature sensor. Calibration: $New\ CFTemp = Old\ CFTemp \times (Thermometer [^{\circ}C] / SBDData_{Temperature} [^{\circ}C])$ <b>Note:</b> $SBDData_{Temperature}$ is reported in 0.1K normally. It must be converted to $^{\circ}C$ for this equation.																						
COTempl	2	-32768	32767	-11375	Correction Offset for Temperature. Offset = 0 used for temperature measurement using internal temperature sensor.																						
CFVPack	2	0	65535	20045	Correction Factor for Pack Voltage. Adjusts the scaling of the pack voltage measurements. Used to calibrate the measurement of pack voltage.																						
COVPack	1	-128	127	0	Correction Offset for Voltage. Offset factor used for pack voltage reading.																						
CalStatus	1	0	255	b00000000	<table border="0"> <tr> <td><b>Bit</b></td> <td><b>Function</b></td> </tr> <tr> <td>7</td> <td>Factory calibrated</td> </tr> <tr> <td>6</td> <td>EE/Flash downloaded</td> </tr> <tr> <td>5</td> <td>RC oscillator</td> </tr> <tr> <td>4</td> <td>External temperature</td> </tr> <tr> <td>3</td> <td>Internal temperature</td> </tr> <tr> <td>2</td> <td>Current</td> </tr> <tr> <td>1</td> <td>Pack voltage</td> </tr> <tr> <td>0</td> <td>Cell voltages</td> </tr> <tr> <td colspan="2">0 = Not calibrated</td> </tr> <tr> <td colspan="2">1 = Calibrated</td> </tr> </table>	<b>Bit</b>	<b>Function</b>	7	Factory calibrated	6	EE/Flash downloaded	5	RC oscillator	4	External temperature	3	Internal temperature	2	Current	1	Pack voltage	0	Cell voltages	0 = Not calibrated		1 = Calibrated	
<b>Bit</b>	<b>Function</b>																										
7	Factory calibrated																										
6	EE/Flash downloaded																										
5	RC oscillator																										
4	External temperature																										
3	Internal temperature																										
2	Current																										
1	Pack voltage																										
0	Cell voltages																										
0 = Not calibrated																											
1 = Calibrated																											

**TABLE 8-3: SAFETY**

Parameter Name	# Bytes	Lower Limit	Upper Limit	Typical Value	Operational Description																											
<b>RemCapAI</b>	2	0	65535	440	SBDData value for <u>RemainingCapacityAlarm</u> . The SBDData specification requires a default of <u>DesignCapacity</u> /10 for this value. When the remaining capacity calculation reaches the value of <b>RemCapAI</b> , the REMAINING_CAPACITY_ALARM bit will be set in the <u>BatteryStatus</u> register and an alarm broadcast to the host will occur if alarm broadcasts are enabled.																											
<b>RemTimeAI</b>	2	0	65535	10	SBDData value for <u>RemainingTimeAlarm</u> . SBDData requires a default of 10 minutes for this value. When the <u>RunTimeToEmpty</u> calculation reaches the value of <b>RemTimeAI</b> , the REMAINING_TIME_ALARM bit in <u>BatteryStatus</u> will be set.																											
<b>MaxTemp</b>	1	0	65535	112	Maximum temperature measured (including external and internal sensor). Coded value = (Celsius * 10 + 200)/4. This is where the PS501-0901 keeps track of the highest temperature it has measured.																											
<b>HighTempAI</b>	1	0	65535	200	OVER_TEMP_ALARM threshold bit in <u>AlarmWarning</u> register, 0.1°C increments, Coded value = (Celsius * 10 + 200)/4. When the temperature exceeds <b>HighTempAI</b> , the OVER_TEMP_ALARM becomes active. If charging, the TERMINATE_CHARGE_ALARM also becomes active.																											
<b>VPackTermChAI</b>	2	0	65535	10800	Pack voltage (mV) which determines when TERMINATE_CHARGE_ALARM is broadcast. This is a voltage higher than the End-Of-Charge voltage that will trigger a TERMINATE_CHARGE_ALARM in case EOC is not responded to by the charger.																											
<b>SleepVPack</b>	2	0	65535	5000	The pack voltage at which the PS501-0901 will enter Low-Voltage Sleep mode.																											
<b>WakeUp</b>	1	0	255	b00001011	When in the Low-Voltage Sleep mode (entry due to low voltage and Sample mode), there are four methods for waking up. They are voltage level, current level, SMBus activity and I/O pin activity. This value defines which wake-up functions are enabled and also the voltage wake-up level. The table below indicates the appropriate setting. Note that the setting is independent of the number of cells or their configuration. Wake-up: <table border="1"> <thead> <tr> <th>Bit</th> <th>Name</th> <th>Function</th> </tr> </thead> <tbody> <tr> <td>7</td> <td>WakeIO</td> <td>Wake-up from I/O activity</td> </tr> <tr> <td>6</td> <td>WakeBus</td> <td>Wake-up from SMBus activity</td> </tr> <tr> <td>5</td> <td>WakeCurr</td> <td>Wake-up from current</td> </tr> <tr> <td>4</td> <td>WakeVolt</td> <td>Wake-up from voltage</td> </tr> <tr> <td>3</td> <td>Shelf-Sleep</td> <td>Use Ultra Low-Power mode for Shelf-Sleep mode</td> </tr> <tr> <td>2</td> <td>Unused</td> <td></td> </tr> <tr> <td>1</td> <td>LV Sleep Mode</td> <td>Use Ultra Low-Power mode as Low-Voltage Sleep mode</td> </tr> <tr> <td>0</td> <td>Zero Remcap</td> <td>Set remcap to zero when entering Low-Voltage Sleep mode</td> </tr> </tbody> </table>	Bit	Name	Function	7	WakeIO	Wake-up from I/O activity	6	WakeBus	Wake-up from SMBus activity	5	WakeCurr	Wake-up from current	4	WakeVolt	Wake-up from voltage	3	Shelf-Sleep	Use Ultra Low-Power mode for Shelf-Sleep mode	2	Unused		1	LV Sleep Mode	Use Ultra Low-Power mode as Low-Voltage Sleep mode	0	Zero Remcap	Set remcap to zero when entering Low-Voltage Sleep mode
Bit	Name	Function																														
7	WakeIO	Wake-up from I/O activity																														
6	WakeBus	Wake-up from SMBus activity																														
5	WakeCurr	Wake-up from current																														
4	WakeVolt	Wake-up from voltage																														
3	Shelf-Sleep	Use Ultra Low-Power mode for Shelf-Sleep mode																														
2	Unused																															
1	LV Sleep Mode	Use Ultra Low-Power mode as Low-Voltage Sleep mode																														
0	Zero Remcap	Set remcap to zero when entering Low-Voltage Sleep mode																														
<b>WakeUpLevels</b>	2	0	255	0	<table border="1"> <thead> <tr> <th><u>WakeUp (2:0)</u></th> <th><u>Voltage</u></th> <th><u>Purpose</u></th> </tr> </thead> <tbody> <tr> <td>000</td> <td>6.4V</td> <td>2 cells Li Ion</td> </tr> <tr> <td>001</td> <td>6.66V</td> <td>6 cells NiMH</td> </tr> <tr> <td>010</td> <td>8.88V</td> <td>8 cells NiMH</td> </tr> <tr> <td>011</td> <td>9.6V</td> <td>3 cells Li Ion</td> </tr> <tr> <td>100</td> <td>9.99V</td> <td>9 cells NiMH</td> </tr> <tr> <td>101</td> <td>11.1V</td> <td>10 cells NiMH</td> </tr> <tr> <td>110</td> <td>12.8V</td> <td>4 cells Li Ion</td> </tr> <tr> <td>111</td> <td>13.3V</td> <td>12 cells NiMH</td> </tr> </tbody> </table>	<u>WakeUp (2:0)</u>	<u>Voltage</u>	<u>Purpose</u>	000	6.4V	2 cells Li Ion	001	6.66V	6 cells NiMH	010	8.88V	8 cells NiMH	011	9.6V	3 cells Li Ion	100	9.99V	9 cells NiMH	101	11.1V	10 cells NiMH	110	12.8V	4 cells Li Ion	111	13.3V	12 cells NiMH
<u>WakeUp (2:0)</u>	<u>Voltage</u>	<u>Purpose</u>																														
000	6.4V	2 cells Li Ion																														
001	6.66V	6 cells NiMH																														
010	8.88V	8 cells NiMH																														
011	9.6V	3 cells Li Ion																														
100	9.99V	9 cells NiMH																														
101	11.1V	10 cells NiMH																														
110	12.8V	4 cells Li Ion																														
111	13.3V	12 cells NiMH																														

# PS501-0901

TABLE 8-4: CHARGE AND DISCHARGE

Parameter Name	# Bytes	Lower Limit	Upper Limit	Typical Value	Operational Description																		
ChrgVolt	2	0	65535	65535	This is the voltage required by the battery during normal charging.																		
ChrgCurr	2	0	65535	3500	This is the full charging current that the battery requires during normal charging. It can be broadcasted to the charger or read from the PS501-0901.																		
ChrgVoltOff	2	0	65535	0	The voltage requested by the battery when charging is complete.																		
ChrgCurrOff	2	0	65535	100	Trickle charging current. This is a small amount of current that the charger should deliver when full charging needs to be halted temporarily due to high temperature.																		
PrechargeCurr	2	0	65535	300	Precharge nominal current.																		
ChrgMinTemp	2	0	65535	50	Low temperature threshold, charging coded value = (Temp [°C] * 10 + 200)/4. When charging, if the temperature is less than <b>ChrgMinTemp</b> , then <u>ChargingCurrent</u> is set to <b>ChrgCurrOff</b> and <u>ChargingVoltage</u> is set to <b>ChrgVoltOff</b> .																		
ChrgMaxTemp	2	0	65535	175	Temperature threshold when charging, coded value = (Temp [°C] * 10 + 200)/4. When the temperature exceeds <b>ChrgMaxTemp</b> and the battery is charging, then <u>ChargingCurrent</u> is set to <b>ChrgCurrOff</b> and <u>ChargingVoltage</u> is set to <b>ChrgVoltOff</b> .																		
PrechargeTemp	2	0	65535	50	Precharge temperature, coded value = (Temp [°C] * 10 + 200)/4. This is the temperature under which precharging should occur.																		
PrechargeVPack	2	0	65535	7000	Precharge pack voltage. This is the voltage under which precharging should occur.																		
PrechargeMax	2	0	65535	500	Precharge max current.																		
ConfigEOC	1	0	255	b11001111	Bit coded as follows: <table border="1"> <thead> <tr> <th>Bit</th> <th>Function</th> </tr> </thead> <tbody> <tr> <td>7</td> <td>EOC on <b>EOCTimer</b></td> </tr> <tr> <td>6</td> <td>EOC on <b>TCAVolt</b></td> </tr> <tr> <td>5</td> <td>Limit remcap to FCC</td> </tr> <tr> <td>4</td> <td>Set overcharge alarm at EOC</td> </tr> <tr> <td>3</td> <td>Load remcap with FCC at EOC</td> </tr> <tr> <td>2</td> <td>EOC on RSOC &gt; <b>MaxSOC</b></td> </tr> <tr> <td>1</td> <td>EOC on -dV</td> </tr> <tr> <td>0</td> <td>EOC on dT/dt</td> </tr> </tbody> </table>	Bit	Function	7	EOC on <b>EOCTimer</b>	6	EOC on <b>TCAVolt</b>	5	Limit remcap to FCC	4	Set overcharge alarm at EOC	3	Load remcap with FCC at EOC	2	EOC on RSOC > <b>MaxSOC</b>	1	EOC on -dV	0	EOC on dT/dt
Bit	Function																						
7	EOC on <b>EOCTimer</b>																						
6	EOC on <b>TCAVolt</b>																						
5	Limit remcap to FCC																						
4	Set overcharge alarm at EOC																						
3	Load remcap with FCC at EOC																						
2	EOC on RSOC > <b>MaxSOC</b>																						
1	EOC on -dV																						
0	EOC on dT/dt																						
ConfigEOD	1	0	255	b11111100	Bit coded as follows: <table border="1"> <thead> <tr> <th>Bit</th> <th>Function</th> </tr> </thead> <tbody> <tr> <td>7</td> <td>Evaluate EOD1 on fixed voltage (else look-up table)</td> </tr> <tr> <td>6</td> <td>Set fully charged bit on EOD1</td> </tr> <tr> <td>5</td> <td>Set capacity to residual capacity value on VEOD1</td> </tr> <tr> <td>4</td> <td>Set TERMINATE_DISCHARGE_ALARM on VEOD1 (0 on VEOD2)</td> </tr> <tr> <td>3</td> <td>Learn FCC at VEOD1</td> </tr> <tr> <td>2</td> <td>TERMINATE_DISCHARGE_ALARM on EOD2</td> </tr> <tr> <td>1</td> <td>Set capacity to zero at VEOD2</td> </tr> <tr> <td>0</td> <td>Do not allow remcap &lt; <b>EOD1Cap</b></td> </tr> </tbody> </table>	Bit	Function	7	Evaluate EOD1 on fixed voltage (else look-up table)	6	Set fully charged bit on EOD1	5	Set capacity to residual capacity value on VEOD1	4	Set TERMINATE_DISCHARGE_ALARM on VEOD1 (0 on VEOD2)	3	Learn FCC at VEOD1	2	TERMINATE_DISCHARGE_ALARM on EOD2	1	Set capacity to zero at VEOD2	0	Do not allow remcap < <b>EOD1Cap</b>
Bit	Function																						
7	Evaluate EOD1 on fixed voltage (else look-up table)																						
6	Set fully charged bit on EOD1																						
5	Set capacity to residual capacity value on VEOD1																						
4	Set TERMINATE_DISCHARGE_ALARM on VEOD1 (0 on VEOD2)																						
3	Learn FCC at VEOD1																						
2	TERMINATE_DISCHARGE_ALARM on EOD2																						
1	Set capacity to zero at VEOD2																						
0	Do not allow remcap < <b>EOD1Cap</b>																						
ClrFullyDischrg	1	0	255	10	Clear fully discharged bit (%). Once fully discharged bit is set, it will stay set until capacity rises above this value, typically 10%.																		

**TABLE 8-4: CHARGE AND DISCHARGE (CONTINUED)**

Parameter Name	# Bytes	Lower Limit	Upper Limit	Typical Value	Operational Description
<b>EOCVolt</b>	2	0	65535	7000	Pack voltage (mV) at which the algorithm will start to monitor the selected EOC options to determine the EOC point.
<b>ClrFullyChrg</b>	1	0	255	90	Clear fully charged bit (%). Once the FULLY_CHARGED bit is set, it will remain set until the battery has discharged to less than 90%.
<b>EOD1Voltage</b>	2	0	65535	6000	First End-Of-Discharge voltage (mV) point if using a fixed voltage instead of look-up table.
<b>RelearnCurrLim</b>	2	0	65535	10000	Value of measured current that prevents a capacity relearn from occurring when a terminate discharge alarm condition is reached at End-Of-Discharge (EOD). A learning cycle will happen when the battery discharges from fully charged, all the way to fully discharged, with no charging in between and the discharge current never exceeds <b>RelearnCurrLim</b> (Example: 3000). A relearn will only occur if current does not exceed 3000 mA.
<b>RelearnMaxErr</b>	2	0	65535	300	Maximum error for learning <b>FullCapacity</b> . The <b>FullCapacity</b> will not be learned after a learning cycle if the error is too great.
<b>EOD1Recheck</b>	1	0	255	2	Number of operating cycles where the voltage must be below the selected End-Of-Discharge voltage for a valid EOD1.
<b>EOD2Recheck</b>	1	0	255	0	Number of operating cycles where the voltage must be below the selected End-Of-Discharge voltage for a valid EOD2.
<b>EOD2Voltage</b>	2	0	65535	5400	Second End-Of-Discharge voltage (mV) point.
<b>NChangeState</b>	1	0	255	2	State change delay filter. Delays the change between "charge increasing" state and "charge decreasing" state based on current direction. To avoid problems with current spikes in opposite directions, a delay filter is built in to control when to change from charging status to discharging status. The current must change directions and stay in the new direction for this many operational cycles before the status is changed and capacity is increased or decreased as a result of the new current direction.
<b>ADLNearEmpty</b>	1	0	255	6500	Pack voltage (mV) at which A/D changes to a measurement list optimized for near EOD.
<b>ADLNearFull</b>	1	0	255	7000	Pack voltage (mV) at which A/D changes to a measurement list optimized for near EOC.
<b>RemCapDelta</b>	1	0	255	1	Maximum change in remaining capacity (mAh) per measurement period during charge.
<b>EOCTimeout</b>	2	0	65535	35156	If selected as an EOC termination method, an EOC condition will be valid when charge time exceeds this value (units: 1.024 seconds).
<b>MaxDischTemp</b>	1	0	255	255	Temperature threshold when discharging, coded value = (Celsius * 10 + 200)/4. When discharging, if the temperature exceeds this value, <u>ChargingCurrent</u> is set to <b>ChrgCurrOff</b> and <u>ChargingVoltage</u> is set to <b>ChrgVoltOff</b> .
<b>EOCSample</b>	1	0	255	58	Time (units: 1.024 seconds) between EOC condition evaluation.
<b>EOCdTTemp</b>	1	0	255	3	Minimum temperature change between <b>EOCSample</b> to cause a temperature EOC (units: 0.4°C).
<b>EOCdTSOC</b>	1	0	255	95	Relative SOC is set to this value after a full charge temperature EOC condition occurs (%).

# PS501-0901

TABLE 8-4: CHARGE AND DISCHARGE (CONTINUED)

Parameter Name	# Bytes	Lower Limit	Upper Limit	Typical Value	Operational Description
EOCdVDelay	1	0	255	5	Delay, after Start-Of-Charge, before full charge -dV EOC conditions can be considered (minutes).
EOCdVVoltDrop	2	0	65535	60	Minimum voltage drop change to cause a -dV EOC. Typically, 10 mV per series cell.
EOCdVCurr	2	0	65535	1000	Minimum current (mA) required for -dV EOC to be considered.
EOCChrgMaxSOC	1	0	255	120	Overcharge EOC (%). If the Start-Of-Charge exceeds this value (%), End-Of-Charge will be triggered.

TABLE 8-5: CAPACITY

Parameter Name	# Bytes	Lower Limit	Upper Limit	Typical Value	Operational Description																		
InitialCap	2	0	65535	2048	The initial capacity (mAh) of the battery. When the PS501-0901 is first powered up and initialized, remaining capacity will take the value programmed into <b>InitialCap</b> to compute relative State-Of-Charge percentage.																		
ConfigCap	1	0	255	0b11010000	Bit coded as follows: <table border="1"> <thead> <tr> <th>Bit</th> <th>Function</th> </tr> </thead> <tbody> <tr> <td>7</td> <td>Compensated remcap</td> </tr> <tr> <td>6</td> <td>Remcap decreasing only</td> </tr> <tr> <td>5</td> <td>Compensated FCC</td> </tr> <tr> <td>4</td> <td>Limit RSOC to 99% until EOC</td> </tr> <tr> <td>3</td> <td>Report compensated FCC</td> </tr> <tr> <td>2</td> <td>Increase capacity on discharge to charge transition</td> </tr> <tr> <td>1</td> <td>Learn FCC unconditionally</td> </tr> <tr> <td>0</td> <td>Self-discharge disabled</td> </tr> </tbody> </table>	Bit	Function	7	Compensated remcap	6	Remcap decreasing only	5	Compensated FCC	4	Limit RSOC to 99% until EOC	3	Report compensated FCC	2	Increase capacity on discharge to charge transition	1	Learn FCC unconditionally	0	Self-discharge disabled
Bit	Function																						
7	Compensated remcap																						
6	Remcap decreasing only																						
5	Compensated FCC																						
4	Limit RSOC to 99% until EOC																						
3	Report compensated FCC																						
2	Increase capacity on discharge to charge transition																						
1	Learn FCC unconditionally																						
0	Self-discharge disabled																						
EOD1Cap	2	0	65535	0	The capacity (mAh) that remains in the battery at VEOD1. This is typically a small amount used to power a shutdown sequence for the system.																		
FullCapacity	2	0	65535	3700	Learned value of battery capacity (mAh). Used for SBData value of <u>FullChargeCapacity</u> . This is a learned parameter, which is the equivalent of all charge counted from fully charged to fully discharged, including self-discharge and error terms. This is reset after a learning cycle and used for remaining capacity and relative State-Of-Charge calculations.																		
CapErrReset	2	0	65535	0	Value to set <b>MaxError</b> to at EOD.																		
RLCycles	1	0	255	2	The number of initial cycles without <b>RelearnLimit</b> . The initial number of cycles where <b>RelearnLimit</b> is not active. <b>FullCapacity</b> can vary greatly with the first learning cycle, since the initial capacity may not be correct, thus this should be set to at least '2'.																		
DesignCapacity	2	0	65535	3700	SBData value for <u>DesignCapacity</u> . This is the capacity (mAh) loaded into the <u>FullChargeCapacity</u> upon power-up.																		
mWhConv	2	0	65535	20000	Constant for conversion from mAh to mWh.																		

## 9.0 ELECTRICAL CHARACTERISTICS

**TABLE 9-1: ABSOLUTE MAXIMUM RATINGS**

Symbol	Parameter	Min	Max	Units
VCX	Voltage at any VC(x) pin	-0.5	18.5	V
VPIN	Voltage directly at any pin (except VC(x))	-0.5	7.0	V
TBIAS	Temperature under Bias	-20	85	°C
TSTORAGE	Storage Temperature (package dependent)	-35	125	°C

**Note 1:** These are stress ratings only. Stress greater than the listed ratings may cause permanent damage to the device. Exposure to absolute maximum ratings for an extended period may affect device reliability. Functional operation is implied only at the listed operating conditions below.

**TABLE 9-2: DC CHARACTERISTICS (TA = -20°C TO +85°C; V REG (INTERNAL) = +3.3V ±10%)**

Symbol	Characteristic	Min	Typ	Max	Units	Condition
VSUPPLY	Supply Voltage – Applied to VC(1)	5.6	—	18.0	V	
VDDA	Supply Voltage – Output from Internal Regulator on VDDA pin	4.5	5.0	5.5	V	(Note 1)
IDD	Instantaneous Supply Current	—	375	400	µA	(Note 2)
IDDRUN	Average Supply Current – Run Mode	—	300	385	µA	A/D active (Note 2)
IDDINS	Inactive Supply Current – Sample Mode	—	225	250	µA	A/D inactive (Note 2,3)
IDDSLEEP	Average Supply Current – Sleep Mode	—	12	25	µA	Sleep mode (Note 2)
IWAKE	Wake-up Current Threshold from Sleep Mode – Voltage across Sense Resistor	2.50	3.75	5.00	mV	
VIL	Input Low Voltage – GPIO(7-0)	—	—	0.2 * VDDD	V	
VIH	Input High Voltage – GPIO(7-0)	0.8 * VDDD	—	—	V	
IIL-IOPU	GPIO Input Low Current – Pull-up Mode	—	50	—	µA	
IiH-IOPD	GPIO Input High Current – Pull-down Mode	—	25	—	µA	
IL	Leakage Current – GPIO pins Programmed as Outputs	—	1	2	µA	
VOL	Output Low Voltage for GPIO(7-0)	—	—	0.4	V	IoL = 0.5 mA
VOH-IO	Output High Voltage for GPIO(7-0) (non-LED mode)	2.0	—	—	V	IoH = 100 µA
VOH-LED	Output High Voltage for GPIO(7-0) (LED mode)	2.0	—	—	V	IoH = 10 mA (Note 4)
VSR	Sense Resistor Input Voltage Range	-152	—	152	mV	
VNTC	Thermistor Input Voltage Range	0	—	152	mV	
VREFT	NTC Reference Voltage Output at VREFT pin	—	150	—	mV	
VIL-SMB	Input Low Voltage for SMBus pins	-0.5	—	0.8	V	
VIH-SMB	Input High Voltage for SMBus pins	2.0	—	5.5	V	
VOL-SMB	Output Low Voltage for SMBus pins	—	—	0.4	V	IPULLUP = 350 µA
VOH-SMB	Output High Voltage for SMBus pins	2.1	—	5.5	V	
IPULLUP-SMB	Current through Pull-up Resistor or Current Source for SMBus pins	100	—	350	µA	
I <sub>LEAK-SMB</sub>	Input Leakage Current – SMBus pins	—	—	± 5	µA	

**Note 1:** VREG is the on-chip regulator voltage. It is internally connected to the analog supply voltage and is output on the VDDA pin.

**2:** Does not include current consumption due to external loading on pins.

**3:** Sample mode current is specified during an A/D inactive cycle. Sample mode average current can be calculated using the formula: Average Sample Mode Supply Current = (IDDRUN + (n – 1) \* IDDINS)/n; where “n” is the programmed sample rate.

**4:** During LED illumination, currents may peak at 10 mA, but average individual LED current is typically 5 mA (using low-current, high brightness devices).

# PS501-0901

**TABLE 9-3: AC CHARACTERISTICS (TA = -20°C TO +85°C; V REG (INTERNAL) = +3.3V ±10%)**

Symbol	Characteristic	Min	Typ	Max	Units	Condition
dfRC	Internal RC Oscillator Frequency	—	512	—	kHz	
t <sub>CONV</sub>	A/D Conversion Measurement Time, n-bit + sign	—	2 <sup>n</sup> /fA/D	—	ms	

**TABLE 9-4: AC CHARACTERISTICS: SMBus (TA = -20°C TO +85°C; V REG (INTERNAL) = +3.3V ±10%)**

Symbol	Characteristic	Min	Typ	Max	Units	Condition
fSMB	SMBus Clock Operating Frequency	<1.0	—	100	kHz	Slave mode
fSMB-MAS	SMBus Clock Operating Frequency	50	fRC/8	68	kHz	Master mode ( <b>Note 1</b> )
tBUF	Bus Free Time between Start and Stop	4.7	—	—	μs	
tSHLD	Bus Hold Time after Repeated Start	4.0	—	—	μs	
tSU:STA	Setup Time before Repeated Start	4.7	—	—	μs	
tSU:STOP	Stop Setup Time	4.0	—	—	μs	
tHLD	Data Hold Time	300	—	—	μs	
tSETUP	Data Setup Time	250	—	—	μs	
tTIMEOUT	Clock Low Time-out Period	10	—	35	ms	<b>(Note 2)</b>
tLOW	Clock Low Period	4.7	—	—	μs	
tHIGH	Clock High Period	4.0	—	50	μs	<b>(Note 3)</b>
tLOW:SEXT	Message Buffering Time	—	—	10	ms	<b>(Note 4)</b>
tLOW:MEXT	Message Buffering Time	—	—	10	ms	<b>(Note 5)</b>
tF	Clock/Data Fall Time	—	—	300	ns	<b>(Note 6)</b>
tR	Clock/Data Rise Time	—	—	1000	ns	<b>(Note 6)</b>

- Note 1:** Used when broadcasting AlarmWarning, ChargingCurrent, and/or ChargingVoltage values to either a SMBus host or a SMBus Smart Battery Charger. This is only used when the PS501-0901 becomes an SMBus master for these functions. The receiving (slave) device may slow the transfer frequency. See the SMBus tutorial in “PS401 User’s Guide” (DS40239) for additional information.
- 2:** The PS501-0901 will time-out when the cumulative message time defined from Start-to-Ack, Ack-to-Ack or Ack-to-Stop exceeds the value of tTIMEOUT, min. of 25 ms. The PS501-0901 will reset the communication no later than tTIMEOUT, max. of 35 ms.
- 3:** tHIGH max. provides a simple, ensured method for devices to detect bus Idle conditions.
- 4:** tLOW:SEXT is the cumulative time a slave device is allowed to extend the clock cycles in one message from the initial start to the stop.
- 5:** tLOW:MEXT is the cumulative time a master device is allowed to extend its clock cycles within each byte of a message as defined from Start-to-Ack, Ack-to-Ack or Ack-to-Stop.
- 6:** Rise and fall time is defined as follows:  
 $t_R = (V_{IL\_MAX} - 0.15) \text{ to } (V_{IH\_MIN} + 0.15)$   
 $t_F = 0.9 V_{DD} \text{ to } (V_{IL\_MAX} - 0.15)$

**TABLE 9-5: A/D CONVERTER CHARACTERISTICS (TA = -20°C TO +85°C;  
VREG (INTERNAL) = +3.3V ±10%)**

Symbol	Characteristic	Min	Typ	Max	Units	Condition
ADRES	A/D Converter Resolution	8	—	15	bits	(Note 1)
VADIN	A/D Converter Input Voltage Range (internal)	-152	—	152	mV	Differential mode (Note 2)
		0	—	300	mV	Single-Ended mode (Note 2)
EVGAIN	Supply Voltage Gain Error	—	—	0.100	%	
EVOFFSET	Compensated Offset Error	—	—	0.100	%	
ETEMP	Temperature Gain Error	—	—	0.100	%	
EINL	Integrated Nonlinearity Error	—	—	0.004	%	

**Note 1:** Voltage is internal at A/D converter inputs. VSR and VNTC are measured directly. VC(x) inputs are measured using internal level translation circuitry that scales the input voltage range appropriately for the converter.

**FIGURE 9-1: SMBus AC TIMING DIAGRAMS**

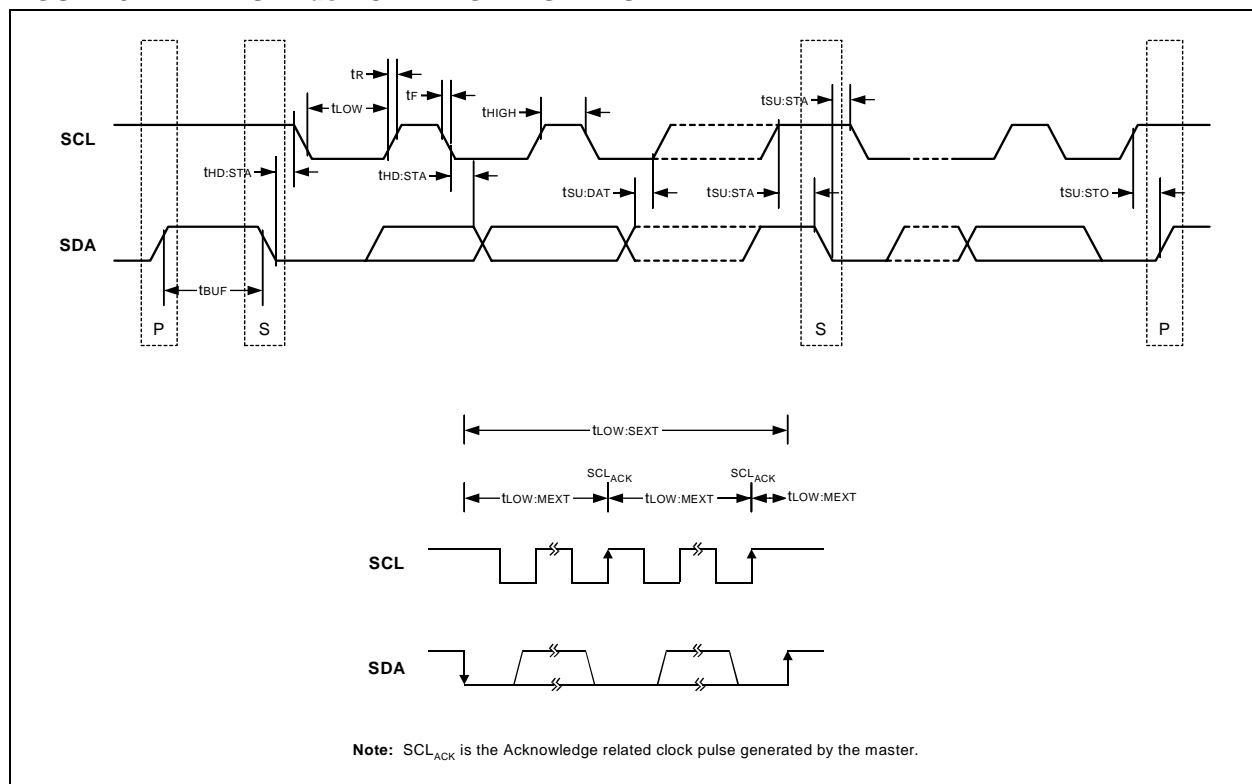

**TABLE 9-6: SILICON TIME BASE CHARACTERISTICS (TA = -20°C TO +85°C;  
VREG (INTERNAL) = +5.0V ±10%)**

Symbol	Characteristic	Min	Typ	Max	Units	Condition
ETIME	Silicon Time Base Error	—	—	0.25	%	Bias Resistor ROSC Tolerance = 1%, TL = ±100 PPM

# PS501-0901

---

## 10.0 PACKAGING INFORMATION

### 10.1 Packaging Marking Information

28-Lead SSOP



Example

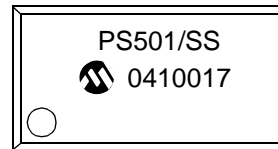

<b>Legend:</b>	XX...X	Customer specific information*
	Y	Year code (last digit of calendar year)
	YY	Year code (last 2 digits of calendar year)
	WW	Week code (week of January 1 is week '01')
	NNN	Alphanumeric traceability code

**Note:** In the event the full Microchip part number cannot be marked on one line, it will be carried over to the next line thus limiting the number of available characters for customer specific information.

- \* Standard device marking consists of Microchip part number, year code, week code, and traceability code. For device marking beyond this, certain price adders apply. Please check with your Microchip Sales Office. For QTP devices, any special marking adders are included in QTP price.

## 10.2 Package Details

The following sections give the technical details of the packages.

### 28-Lead Plastic Shrink Small Outline (SS) – 209 mil Body, 5.30 mm (SSOP)

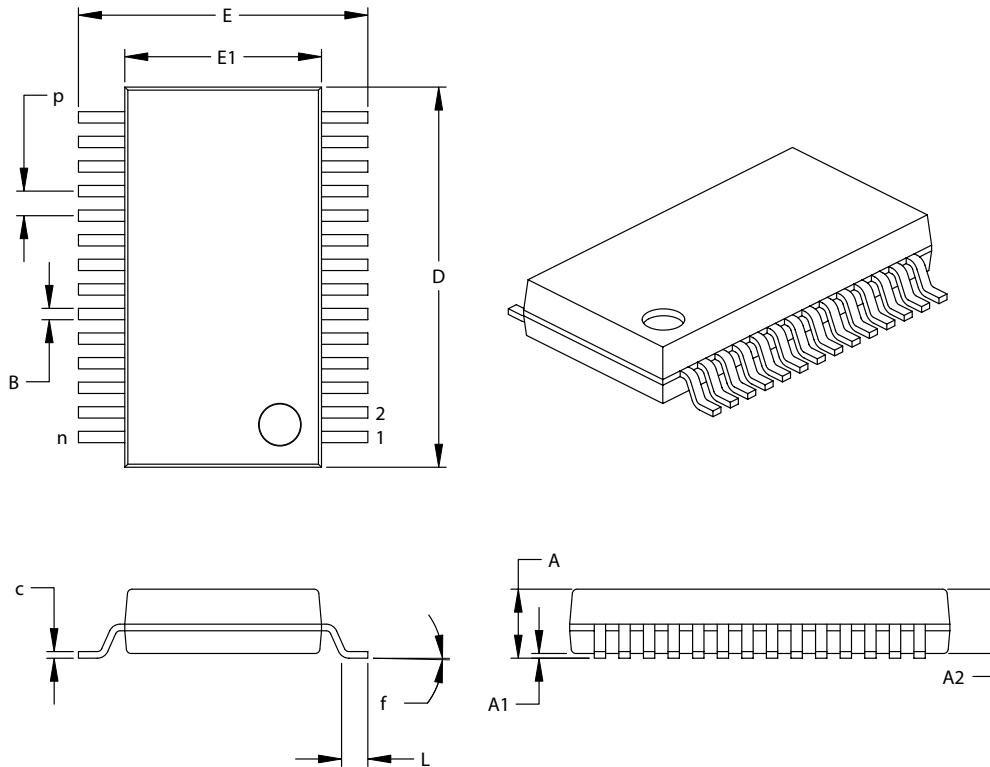

Dimension Limits	Units	INCHES			MILLIMETERS*		
		MIN	NOM	MAX	MIN	NOM	MAX
Number of Pins	n	28			28		
Pitch	P		.026			0.65	
Overall Height	A	-	-	.079	-	-	2.0
Molded Package Thickness	A2	.065	.069	.073	1.65	1.75	1.85
Standoff	A1	.002	-	-	0.05	-	-
Overall Width	E	.295	.307	.323	7.49	7.80	8.20
Molded Package Width	E1	.009	.209	.220	5.00	5.30	5.60
Overall Length	D	.390	.402	.413	9.90	10.20	10.50
Foot Length	L	.022	.030	.037	0.55	0.75	0.95
Lead Thickness	c	.004	-	.010	0.09	-	0.25
Foot Angle	f	0°	4°	8°	0°	4°	8°
Lead Width	B	.009	-	.015	0.22	-	0.38

\*Controlling Parameter

Notes:

Dimensions D and E1 do not include mold flash or protrusions. Mold flash or protrusions shall not exceed .010" (0.254mm) per side.

JEDEC Equivalent: MO-150

Drawing No. C04-073

# PS501-0901

---

NOTES:

Information contained in this publication regarding device applications and the like is intended through suggestion only and may be superseded by updates. It is your responsibility to ensure that your application meets with your specifications. No representation or warranty is given and no liability is assumed by Microchip Technology Incorporated with respect to the accuracy or use of such information, or infringement of patents or other intellectual property rights arising from such use or otherwise. Use of Microchip's products as critical components in life support systems is not authorized except with express written approval by Microchip. No licenses are conveyed, implicitly or otherwise, under any intellectual property rights.

## **Trademarks**

The Microchip name and logo, the Microchip logo, Accuron, PIC, PICmicro, PowerSmart and SmartShunt are registered trademarks of Microchip Technology Incorporated in the U.S.A. and other countries.

SmartSensor is a registered trademark of Microchip Technology Incorporated in the U.S.A.

PowerCal, PowerInfo, PowerMate, PowerTool and SmartTel are trademarks of Microchip Technology Incorporated in the U.S.A. and other countries.

All other trademarks mentioned herein are property of their respective companies.

© 2004, Microchip Technology Incorporated. Printed in the U.S.A., All Rights Reserved.



Printed on recycled paper.



---

---

## WORLDWIDE SALES AND SERVICE

---

---

### AMERICAS

**Corporate Office**  
2355 West Chandler Blvd.  
Chandler, AZ 85224-6199  
Tel: 480-792-7200  
Fax: 480-792-7277  
Technical Support:  
480-792-7627  
Web Address:  
www.microchip.com

**Atlanta**  
Alpharetta, GA  
Tel: 770-640-0034  
Fax: 770-640-0307

**Boston**  
Westford, MA  
Tel: 978-692-3848  
Fax: 978-692-3821

**Chicago**  
Itasca, IL  
Tel: 630-285-0071  
Fax: 630-285-0075

**Dallas**  
Addison, TX  
Tel: 972-818-7423  
Fax: 972-818-2924

**Detroit**  
Farmington Hills, MI  
Tel: 248-538-2250  
Fax: 248-538-2260

**Kokomo**  
Kokomo, IN  
Tel: 765-864-8360  
Fax: 765-864-8387

**Los Angeles**  
Mission Viejo, CA  
Tel: 949-462-9523  
Fax: 949-462-9608

**San Jose**  
Mountain View, CA  
Tel: 650-215-1444  
Fax: 650-961-0286

**Toronto**  
Mississauga, Ontario,  
Canada  
Tel: 905-673-0699  
Fax: 905-673-6509

### ASIA/PACIFIC

**Australia - Sydney**  
Tel: 61-2-9868-6733  
Fax: 61-2-9868-6755

**China - Beijing**  
Tel: 86-10-8528-2100  
Fax: 86-10-8528-2104

**China - Chengdu**  
Tel: 86-28-8676-6200  
Fax: 86-28-8676-6599

**China - Fuzhou**  
Tel: 86-591-750-3506  
Fax: 86-591-750-3521

**China - Hong Kong SAR**  
Tel: 852-2401-1200  
Fax: 852-2401-3431

**China - Shanghai**  
Tel: 86-21-6275-5700  
Fax: 86-21-6275-5060

**China - Shenzhen**  
Tel: 86-755-8290-1380  
Fax: 86-755-8295-1393

**China - Shunde**  
Tel: 86-757-2839-5507  
Fax: 86-757-2839-5571

**China - Qingdao**  
Tel: 86-532-502-7355  
Fax: 86-532-502-7205

### ASIA/PACIFIC

**India - Bangalore**  
Tel: 91-80-2229-0061  
Fax: 91-80-2229-0062

**India - New Delhi**  
Tel: 91-11-5160-8632  
Fax: 91-11-5160-8632

**Japan - Kanagawa**  
Tel: 81-45-471- 6166  
Fax: 81-45-471-6122

**Korea - Seoul**  
Tel: 82-2-554-7200  
Fax: 82-2-558-5932 or  
82-2-558-5934

**Singapore**  
Tel: 65-6334-8870  
Fax: 65-6334-8850

**Taiwan - Kaohsiung**  
Tel: 886-7-536-4816  
Fax: 886-7-536-4817

**Taiwan - Taipei**  
Tel: 886-2-2500-6610  
Fax: 886-2-2508-0102

**Taiwan - Hsinchu**  
Tel: 886-3-572-9526  
Fax: 886-3-572-6459

### EUROPE

**Austria - Weis**  
Tel: 43-7242-2244-399  
Fax: 43-7242-2244-393

**Denmark - Ballerup**  
Tel: 45-4420-9895  
Fax: 45-4420-9910

**France - Massy**  
Tel: 33-1-69-53-63-20  
Fax: 33-1-69-30-90-79

**Germany - Ismaning**  
Tel: 49-89-627-144-0  
Fax: 49-89-627-144-44

**Italy - Milan**  
Tel: 39-0331-742611  
Fax: 39-0331-466781

**Netherlands - Drunen**  
Tel: 31-416-690399  
Fax: 31-416-690340

**England - Berkshire**  
Tel: 44-118-921-5869  
Fax: 44-118-921-5820

08/24/04