



PIC18F6393/6493/8393/8493

Data Sheet

64/80-Pin High-Performance,
Flash Microcontrollers with LCD Driver,
12-Bit ADC and nanoWatt Technology

Note the following details of the code protection feature on Microchip devices:

- Microchip products meet the specification contained in their particular Microchip Data Sheet.
- Microchip believes that its family of products is one of the most secure families of its kind on the market today, when used in the intended manner and under normal conditions.
- There are dishonest and possibly illegal methods used to breach the code protection feature. All of these methods, to our knowledge, require using the Microchip products in a manner outside the operating specifications contained in Microchip's Data Sheets. Most likely, the person doing so is engaged in theft of intellectual property.
- Microchip is willing to work with the customer who is concerned about the integrity of their code.
- Neither Microchip nor any other semiconductor manufacturer can guarantee the security of their code. Code protection does not mean that we are guaranteeing the product as "unbreakable."

Code protection is constantly evolving. We at Microchip are committed to continuously improving the code protection features of our products. Attempts to break Microchip's code protection feature may be a violation of the Digital Millennium Copyright Act. If such acts allow unauthorized access to your software or other copyrighted work, you may have a right to sue for relief under that Act.

Information contained in this publication regarding device applications and the like is provided only for your convenience and may be superseded by updates. It is your responsibility to ensure that your application meets with your specifications. MICROCHIP MAKES NO REPRESENTATIONS OR WARRANTIES OF ANY KIND WHETHER EXPRESS OR IMPLIED, WRITTEN OR ORAL, STATUTORY OR OTHERWISE, RELATED TO THE INFORMATION, INCLUDING BUT NOT LIMITED TO ITS CONDITION, QUALITY, PERFORMANCE, MERCHANTABILITY OR FITNESS FOR PURPOSE. Microchip disclaims all liability arising from this information and its use. Use of Microchip devices in life support and/or safety applications is entirely at the buyer's risk, and the buyer agrees to defend, indemnify and hold harmless Microchip from any and all damages, claims, suits, or expenses resulting from such use. No licenses are conveyed, implicitly or otherwise, under any Microchip intellectual property rights.

QUALITY MANAGEMENT SYSTEM
CERTIFIED BY DNV
== ISO/TS 16949:2002 ==



MICROCHIP

PIC18F6393/6493/8393/8493

64/80-Pin High-Performance, Flash Microcontrollers with LCD Driver, 12-Bit ADC and nanoWatt Technology

LCD Driver Module Features:

- Direct Driving of LCD Panel
- Up to 192 Pixels: Software-Selectable
- Programmable LCD Timing module:
 - Multiple LCD timing sources available
 - Up to four commons: Static, 1/2, 1/3 or 1/4 multiplex
 - Static, 1/2 or 1/3 bias configuration
- Can Drive LCD Panel while in Sleep mode for Low-Power Operation

Power-Managed Modes:

- Run: CPU On, Peripherals On
- Idle: CPU Off, Peripherals On
- Sleep: CPU Off, Peripherals Off
- Ultra Low 50 nA Input Leakage
- Run mode Current Down to 14 μ A Typical
- Idle mode Currents Down to 2.3 μ A Typical
- Sleep mode Currents Down to 0.1 μ A Typical
- Timer1 Oscillator: 1.0 μ A, 32 kHz, 2V Typical
- Watchdog Timer: 1.7 μ A Typical
- Two-Speed Oscillator Start-up

Flexible Oscillator Structure:

- Four Crystal modes, up to 40 MHz
- 4x Phase Lock Loop (available for crystal and internal oscillators)
- Two External RC modes, up to 4 MHz
- Two External Clock modes, up to 40 MHz
- Internal Oscillator Block:
 - Fast wake from Sleep and Idle, 1 μ s typical
 - Eight selectable frequencies, from 31 kHz to 8 MHz
 - Provides a complete range of clock speeds from 31 kHz to 32 MHz when used with PLL
 - User-tunable to compensate for frequency drift
- Secondary Oscillator Using Timer1 at 32 kHz
- Fail-Safe Clock Monitor:
 - Allows for safe shutdown if peripheral clock stops

Peripheral Highlights:

- 12-Bit, up to 12-Channel Analog-to-Digital (A/D) Converter module:
 - Auto-acquisition capability
 - Conversion available during Sleep
- High-Current Sink/Source 25 mA/25 mA
- Four External Interrupts
- Four Input Change Interrupts
- Four 8-Bit/16-Bit Timer/Counter modules
- Real-Time Clock (RTC) Software module:
 - Configurable 24-hour clock, calendar, automatic 100-year or 12,800-year, day-of-week calculator
 - Uses Timer1
- Up to Two Capture/Compare/PWM (CCP) modules
- Master Synchronous Serial Port (MSSP) module Supporting Three-Wire SPI (all four modes) and I²C™ Master and Slave modes
- Addressable USART module:
 - Supports RS-485 and RS-232
- Enhanced Addressable USART module:
 - Supports RS-485, RS-232 and LIN/J2602
 - Auto-wake-up on Start bit
 - Auto-Baud Detect
- Dual Analog Comparators with Input Multiplexing
- Programmable 16-Level High/Low-Voltage Detection (HLVD) module:
 - Supports interrupt on High/Low-Voltage Detection

Special Microcontroller Features:

- C Compiler Optimized Architecture:
 - Optional extended instruction set designed to optimize re-entrant code
- 1000 Erase/Write Cycle Flash Program Memory, Typical
- Flash Retention: 100 Years Typical
- Priority Levels for Interrupts
- 8 x 8 Single-Cycle Hardware Multiplier
- Extended Watchdog Timer (WDT):
 - Programmable period from 4 ms to 132s
 - 2% stability over VDD and temperature
- In-Circuit Serial Programming™ (ICSP™) via Two Pins
- In-Circuit Debug (ICD) via Two Pins
- Wide Operating Voltage Range: 2.0V to 5.5V
- Programmable Brown-out Reset (BOR) with Software Enable Option

Note: This document is supplemented by the "PIC18F6390/6490/8390/8490 Data Sheet" (DS39629). See Section 1.0 "Device Overview".

Device	Program Memory		Data Memory	I/O	LCD (pixel)	12-Bit A/D (channels)	CCP (PWM)	MSSP		EUSART/AUSART	Comparators	Timers 8/16-Bit
	Flash (bytes)	# Single-Word Instructions	SRAM (bytes)					SPI	Master I ² C™			
PIC18F6393	8K	4096	768	50	128	12	2	Y	Y	1/1	2	1/3
PIC18F6493	16K	8192	768	50	128	12	2	Y	Y	1/1	2	1/3
PIC18F8393	8K	4096	768	66	192	12	2	Y	Y	1/1	2	1/3
PIC18F8493	16K	8192	768	66	192	12	2	Y	Y	1/1	2	1/3

PIC18F6393/6493/8393/8493

Pin Diagrams

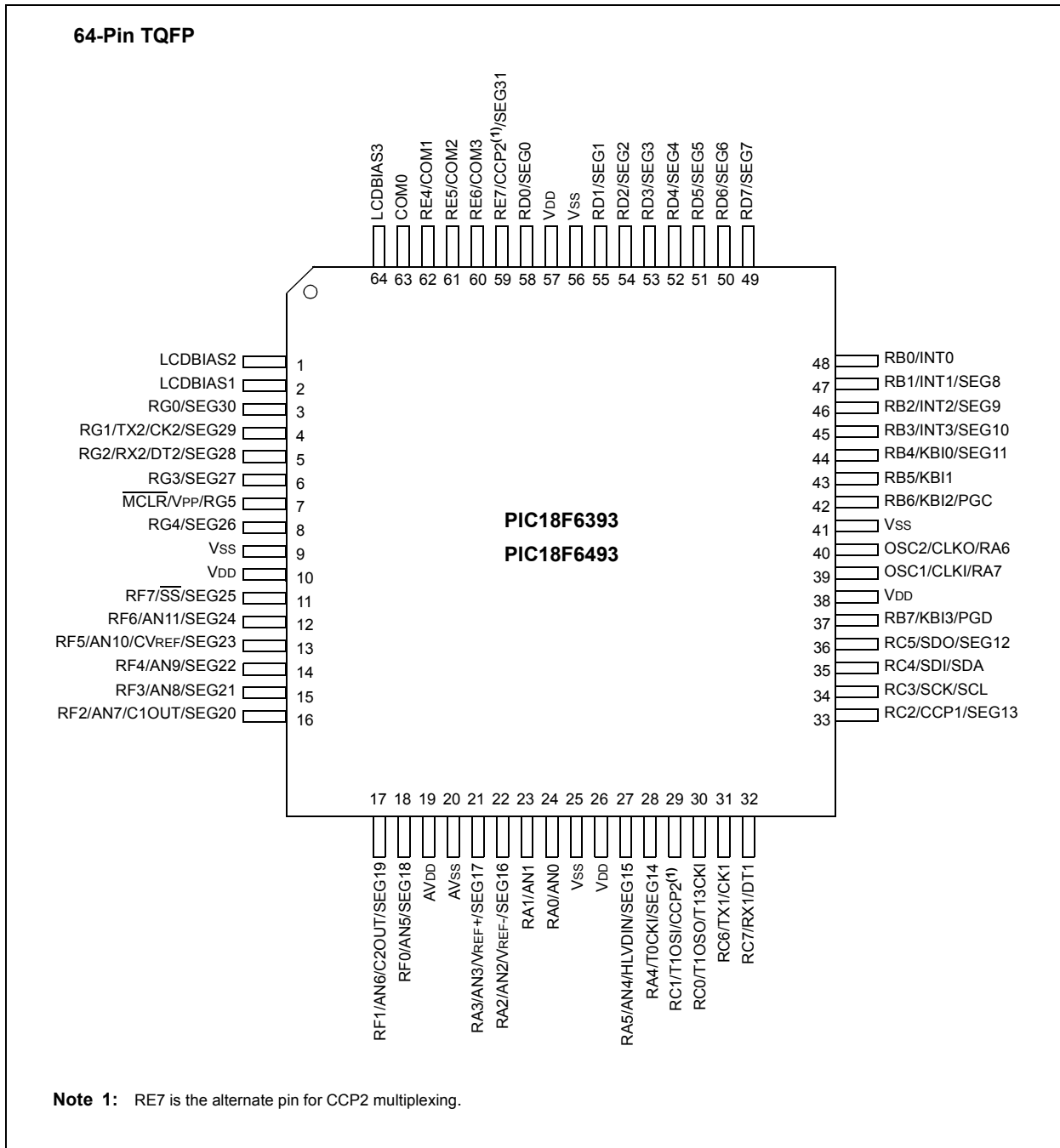

PIC18F6393/6493/8393/8493

Pin Diagrams (Continued)

80-Pin TQFP

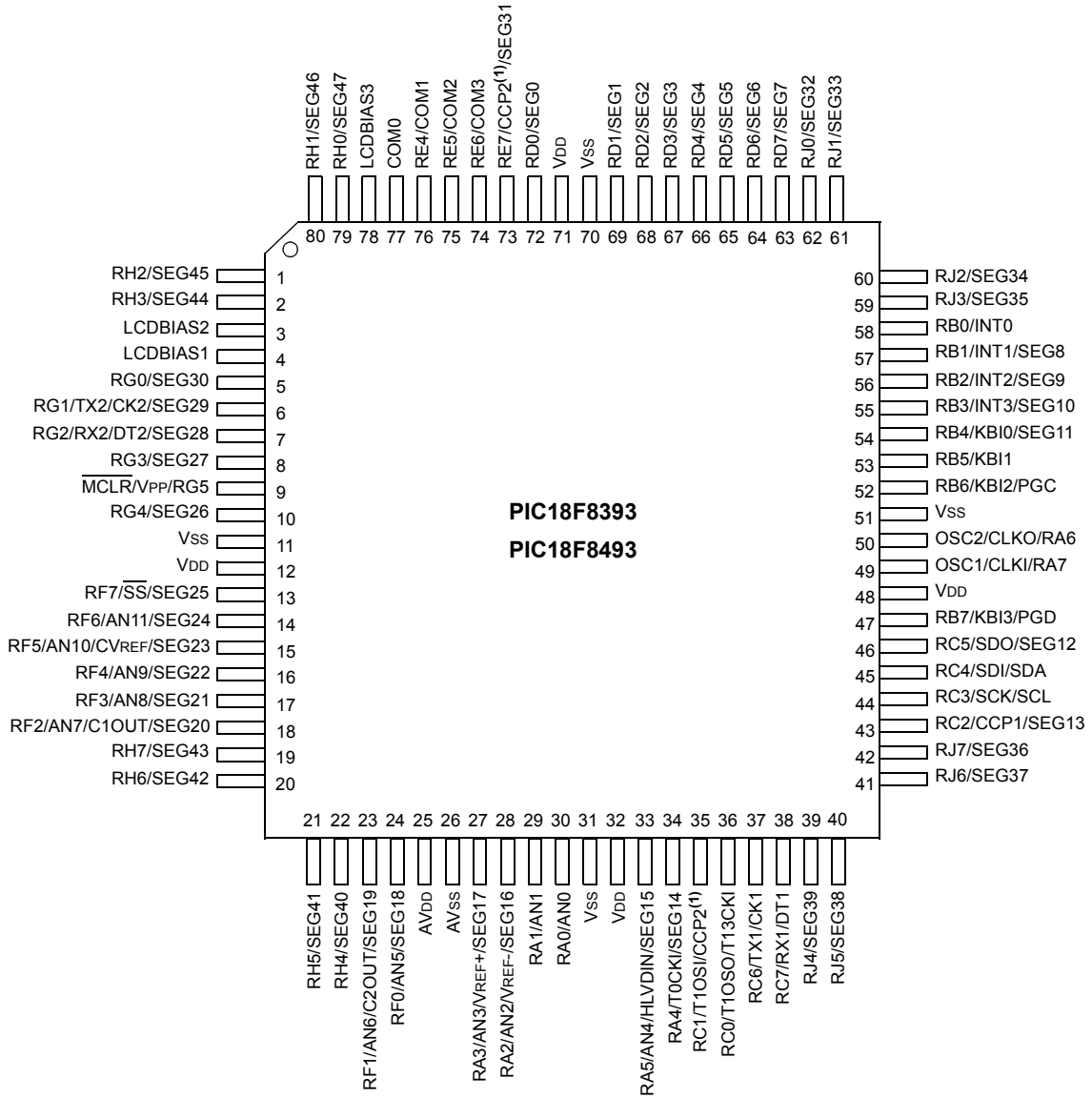

Note 1: RE7 is the alternate pin for CCP2 multiplexing.

PIC18F6393/6493/8393/8493

Table of Contents

1.0	Device Overview	9
2.0	12-Bit Analog-to-Digital Converter (A/D) Module	31
3.0	Special Features of the CPU	41
4.0	Electrical Characteristics	43
5.0	Packaging Information.....	47
	Appendix A: Revision History.....	53
	Appendix B: Device Differences.....	53
	Appendix C: Conversion Considerations	54
	Appendix D: Migration from Baseline to Enhanced Devices.....	54
	Appendix E: migration from Mid-Range to Enhanced Devices	55
	Appendix F: Migration from High-End to Enhanced Devices.....	55
	Index	57
	The Microchip Web Site	59
	Customer Change Notification Service	59
	Customer Support	59
	Reader Response	60
	Product Identification System.....	61

TO OUR VALUED CUSTOMERS

It is our intention to provide our valued customers with the best documentation possible to ensure successful use of your Microchip products. To this end, we will continue to improve our publications to better suit your needs. Our publications will be refined and enhanced as new volumes and updates are introduced.

If you have any questions or comments regarding this publication, please contact the Marketing Communications Department via E-mail at docerrors@microchip.com or fax the **Reader Response Form** in the back of this data sheet to (480) 792-4150. We welcome your feedback.

Most Current Data Sheet

To obtain the most up-to-date version of this data sheet, please register at our Worldwide Web site at:

<http://www.microchip.com>

You can determine the version of a data sheet by examining its literature number found on the bottom outside corner of any page. The last character of the literature number is the version number, (e.g., DS30000A is version A of document DS30000).

Errata

An errata sheet, describing minor operational differences from the data sheet and recommended workarounds, may exist for current devices. As device/documentation issues become known to us, we will publish an errata sheet. The errata will specify the revision of silicon and revision of document to which it applies.

To determine if an errata sheet exists for a particular device, please check with one of the following:

- Microchip's Worldwide Web site; <http://www.microchip.com>
- Your local Microchip sales office (see last page)

When contacting a sales office, please specify which device, revision of silicon and data sheet (include literature number) you are using.

Customer Notification System

Register on our web site at www.microchip.com to receive the most current information on all of our products.

PIC18F6393/6493/8393/8493

NOTES:

PIC18F6393/6493/8393/8493

1.0 DEVICE OVERVIEW

This document contains device-specific information for the following devices:

- PIC18F6393
- PIC18F8393
- PIC18F6493
- PIC18F8493

Note: This data sheet documents only the devices' features and specifications that are in addition to the features and specifications of the PIC18F6390/6490/8390/8490 devices. For information on the features and specifications shared by the PIC18F6393/6493/8393/8493 and PIC18F6390/6490/8390/8490 devices, see the "PIC18F6390/6490/8390/8490 Data Sheet" (DS39629).

This family offers the advantages of all PIC18 microcontrollers – namely, high computational performance at an economical price. In addition to these features, the PIC18F6393/6493/8393/8493 family introduces design enhancements that make these microcontrollers a logical choice for many high-performance, power-sensitive applications.

1.1 Special Features

- **12-Bit A/D Converter:** This module incorporates programmable acquisition time, allowing for a channel to be selected and a conversion to be initiated without waiting for a sampling period and thus, reduces code overhead.

1.2 Details on Individual Family Members

Devices in the PIC18F6393/6493/8393/8493 family are available in 64-pin (PIC18F6X93) and 80-pin (PIC18F8X93) packages. Block diagrams for the two groups are shown in Figure 1-1 and Figure 1-2, respectively.

The devices are differentiated from each other in the following ways:

- I/O Ports:
 - 64-pin devices – 7 bidirectional ports
 - 80-pin devices – 9 bidirectional ports
- LCD Pixels:
 - 64-pin devices – 128 (32 SEGs x 4 COMs) pixels can be driven
 - 80-pin devices – 192 (48 SEGs x 4 COMs) pixels can be driven
- Flash Program Memory:
 - PIC18FX393 devices – 8 Kbytes
 - PIC18FX493 devices – 16 Kbytes

All other features for devices in this family are identical. These are summarized in Table 1-1.

The pinouts for all devices are listed in Table 1-2 and Table 1-3.

Like all Microchip PIC18 devices, members of the PIC18F6393/6493/8393/8493 family are available as both standard and low-voltage devices. Standard devices with Flash memory, designated with an "F" in the part number (such as PIC18F6393), accommodate an operating VDD range of 4.2V to 5.5V. Low-voltage parts, designated by "LF" (such as PIC18LF6490), function over an extended VDD range of 2.0V to 5.5V.

PIC18F6393/6493/8393/8493

TABLE 1-1: DEVICE FEATURES

Features	PIC18F6393	PIC18F6493	PIC18F8393	PIC18F8493
Operating Frequency	DC – 40 MHz	DC – 40 MHz	DC – 40 MHz	DC – 40 MHz
Program Memory (Bytes)	8K	16K	8K	16K
Program Memory (Instructions)	4096	8192	4096	8192
Data Memory (Bytes)	768	768	768	768
Interrupt Sources	22	22	22	22
I/O Ports	Ports A, B, C, D, E, F, G	Ports A, B, C, D, E, F, G	Ports A, B, C, D, E, F, G, H, J	Ports A, B, C, D, E, F, G, H, J
Number of Pixels the LCD Driver Can Drive	128 (32 SEGs x 4 COMs)	128 (32 SEGs x 4 COMs)	192 (48 SEGs x 4 COMs)	192 (48 SEGs x 4 COMs)
Timers	4	4	4	4
Capture/Compare/PWM Modules	2	2	2	2
Serial Communications	MSSP, AUSART, Enhanced USART	MSSP, AUSART, Enhanced USART	MSSP, AUSART, Enhanced USART	MSSP, AUSART, Enhanced USART
12-Bit Analog-to-Digital Module	12 Input Channels	12 Input Channels	12 Input Channels	12 Input Channels
Resets (and Delays)	POR, BOR, RESET Instruction, Stack Full, Stack Underflow (PWRT, OST), MCLR (optional), WDT	POR, BOR, RESET Instruction, Stack Full, Stack Underflow (PWRT, OST), MCLR (optional), WDT	POR, BOR, RESET Instruction, Stack Full, Stack Underflow (PWRT, OST), MCLR (optional), WDT	POR, BOR, RESET Instruction, Stack Full, Stack Underflow (PWRT, OST), MCLR (optional), WDT
Programmable Low-Voltage Detect	Yes	Yes	Yes	Yes
Programmable Brown-out Reset	Yes	Yes	Yes	Yes
Instruction Set	75 Instructions; 83 with Extended Instruction Set Enabled	75 Instructions; 83 with Extended Instruction Set Enabled	75 Instructions; 83 with Extended Instruction Set Enabled	75 Instructions; 83 with Extended Instruction Set Enabled
Packages	64-Pin TQFP	64-Pin TQFP	80-Pin TQFP	80-Pin TQFP

PIC18F6393/6493/8393/8493

FIGURE 1-1: PIC18F6X93 (64-PIN) BLOCK DIAGRAM

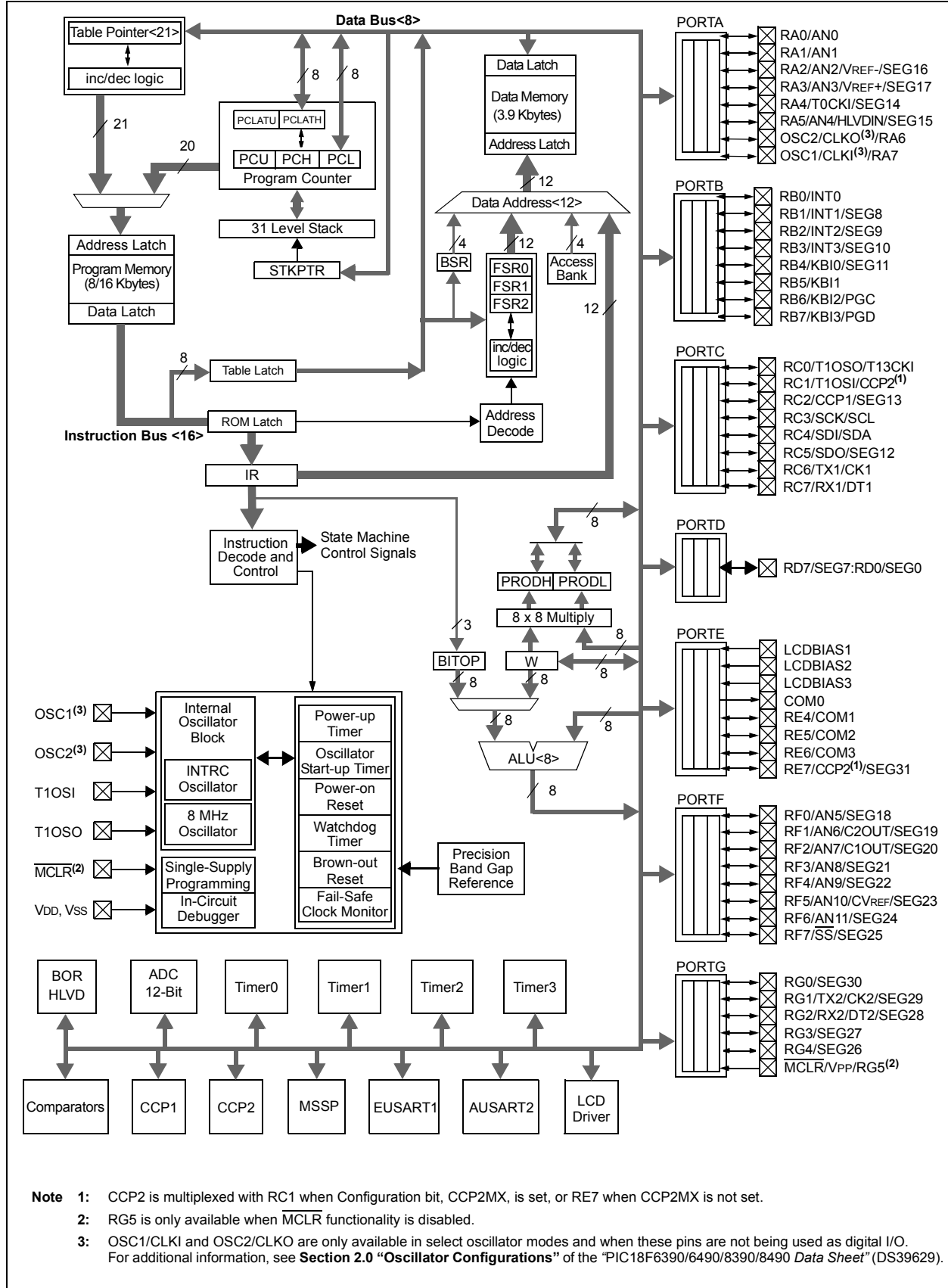

PIC18F6393/6493/8393/8493

FIGURE 1-2: PIC18F8X93 (80-PIN) BLOCK DIAGRAM

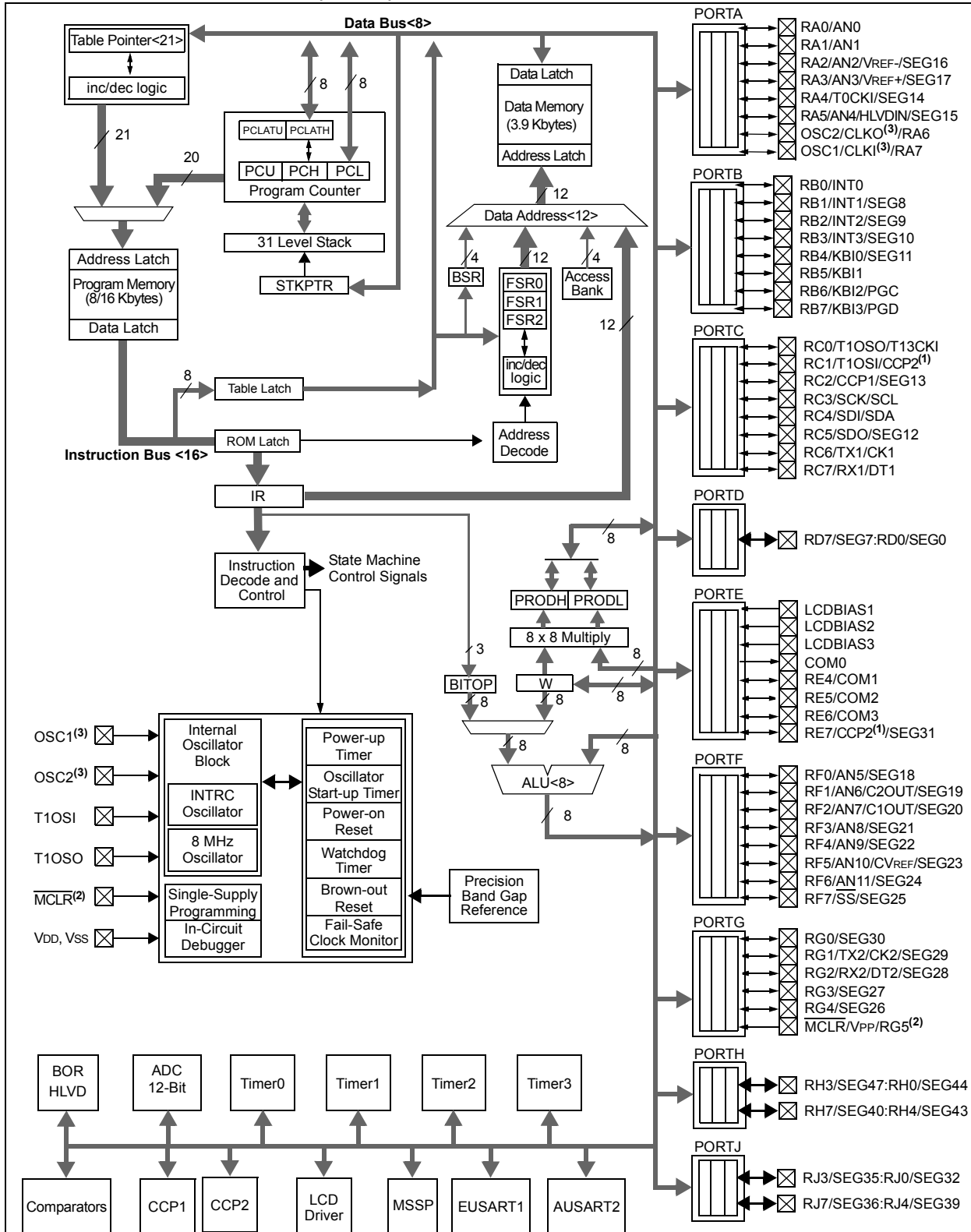

- Note**
- 1: CCP2 is multiplexed with RC1 when Configuration bit, CCP2MX, is set and RE7 when CCP2MX is not set.
 - 2: RG5 is only available when MCLR functionality is disabled.
 - 3: OSC1/CLKI and OSC2/CLKO are only available in select oscillator modes and when these pins are not being used as digital I/O. For additional information, see Section 2.0 "Oscillator Configurations" of the "PIC18F6390/6490/8390/8490 Data Sheet" (DS39629).

PIC18F6393/6493/8393/8493

TABLE 1-2: PIC18F6X93 PINOUT I/O DESCRIPTIONS (CONTINUED)

Pin Name	Pin Number	Pin Type	Buffer Type	Description
	TQFP			
RB0/INT0 RB0 INT0	48	I/O I	TTL ST	PORTB is a bidirectional I/O port. PORTB can be software programmed for internal weak pull-ups on all inputs. Digital I/O. External Interrupt 0.
RB1/INT1/SEG8 RB1 INT1 SEG8	47	I/O I O	TTL ST Analog	Digital I/O. External Interrupt 1. SEG8 output for LCD.
RB2/INT2/SEG9 RB2 INT2 SEG9	46	I/O I O	TTL ST Analog	Digital I/O. External Interrupt 2. SEG9 output for LCD.
RB3/INT3/SEG10 RB3 INT3 SEG10	45	I/O I O	TTL ST Analog	Digital I/O. External Interrupt 3. SEG10 output for LCD.
RB4/KBI0/SEG11 RB4 KBI0 SEG11	44	I/O I O	TTL TTL Analog	Digital I/O. Interrupt-on-change pin. SEG11 output for LCD.
RB5/KBI1 RB5 KBI1	43	I/O I	TTL TTL	Digital I/O. Interrupt-on-change pin.
RB6/KBI2/PGC RB6 KBI2 PGC	42	I/O I I/O	TTL TTL ST	Digital I/O. Interrupt-on-change pin. In-Circuit Debugger and ICSP™ programming clock pin.
RB7/KBI3/PGD RB7 KBI3 PGD	37	I/O I I/O	TTL TTL ST	Digital I/O. Interrupt-on-change pin. In-Circuit Debugger and ICSP programming data pin.

Legend: TTL = TTL compatible input CMOS = CMOS compatible input or output
ST = Schmitt Trigger input with CMOS levels Analog = Analog input
I = Input O = Output
P = Power I²C = ST with I²C™ or SMB levels

Note 1: Default assignment for CCP2 when Configuration bit, CCP2MX, is set.
2: Alternate assignment for CCP2 when Configuration bit, CCP2MX, is cleared.

PIC18F6393/6493/8393/8493

TABLE 1-2: PIC18F6X93 PINOUT I/O DESCRIPTIONS (CONTINUED)

Pin Name	Pin Number	Pin Type	Buffer Type	Description
	TQFP			
RC0/T1OSO/T13CKI	30			PORTC is a bidirectional I/O port.
RC0		I/O	ST	Digital I/O.
T1OSO		O	—	Timer1 oscillator output.
T13CKI		I	ST	Timer1/Timer3 external clock input.
RC1/T1OSI/CCP2	29			
RC1		I/O	ST	Digital I/O.
T1OSI		I	Analog	Timer1 oscillator input.
CCP2 ⁽¹⁾		I/O	ST	Capture 2 input/Compare 2 output/PWM2 output.
RC2/CCP1/SEG13	33			
RC2		I/O	ST	Digital I/O.
CCP1		I/O	ST	Capture 1 input/Compare 1 output/PWM1 output.
SEG13		O	Analog	SEG13 output for LCD.
RC3/SCK/SCL	34			
RC3		I/O	ST	Digital I/O.
SCK		I/O	ST	Synchronous serial clock input/output for SPI mode.
SCL		I/O	I ² C	Synchronous serial clock input/output for I ² C™ mode.
RC4/SDI/SDA	35			
RC4		I/O	ST	Digital I/O.
SDI		I	ST	SPI data in.
SDA		I/O	I ² C	I ² C data I/O.
RC5/SDO/SEG12	36			
RC5		I/O	ST	Digital I/O.
SDO		O	—	SPI data out.
SEG12		O	Analog	SEG12 output for LCD.
RC6/TX1/CK1	31			
RC6		I/O	ST	Digital I/O.
TX1		O	—	EUSART1 asynchronous transmit.
CK1		I/O	ST	EUSART1 synchronous clock (see related RX1/DT1).
RC7/RX1/DT1	32			
RC7		I/O	ST	Digital I/O.
RX1		I	ST	EUSART1 asynchronous receive.
DT1		I/O	ST	EUSART1 synchronous data (see related TX1/CK1).

Legend: TTL = TTL compatible input CMOS = CMOS compatible input or output
ST = Schmitt Trigger input with CMOS levels Analog = Analog input
I = Input O = Output
P = Power I²C = ST with I²C™ or SMB levels

Note 1: Default assignment for CCP2 when Configuration bit, CCP2MX, is set.
2: Alternate assignment for CCP2 when Configuration bit, CCP2MX, is cleared.

PIC18F6393/6493/8393/8493

TABLE 1-2: PIC18F6X93 PINOUT I/O DESCRIPTIONS (CONTINUED)

Pin Name	Pin Number	Pin Type	Buffer Type	Description
	TQFP			
				PORTE is a bidirectional I/O port.
LCDBIAS1 LCDBIAS1	2	I	Analog	BIAS1 input for LCD.
LCDBIAS2 LCDBIAS2	1	I	Analog	BIAS2 input for LCD.
LCDBIAS3 LCDBIAS3	64	I	Analog	BIAS3 input for LCD.
COM0 COM0	63	O	Analog	COM0 output for LCD.
RE4/COM1 RE4 COM1	62	I/O O	ST Analog	Digital I/O. COM1 output for LCD.
RE5/COM2 RE5 COM2	61	I/O O	ST Analog	Digital I/O. COM2 output for LCD.
RE6/COM3 RE6 COM3	60	I/O O	ST Analog	Digital I/O. COM3 output for LCD.
RE7/CCP2/SEG31 RE7 CCP2 ⁽²⁾ SEG31	59	I/O I/O O	ST ST Analog	Digital I/O. Capture 2 input/Compare 2 output/PWM2 output. SEG31 output for LCD.

Legend: TTL = TTL compatible input CMOS = CMOS compatible input or output
 ST = Schmitt Trigger input with CMOS levels Analog = Analog input
 I = Input O = Output
 P = Power I²C = ST with I²C™ or SMB levels

Note 1: Default assignment for CCP2 when Configuration bit, CCP2MX, is set.
2: Alternate assignment for CCP2 when Configuration bit, CCP2MX, is cleared.

PIC18F6393/6493/8393/8493

TABLE 1-2: PIC18F6X93 PINOUT I/O DESCRIPTIONS (CONTINUED)

Pin Name	Pin Number	Pin Type	Buffer Type	Description
	TQFP			
RF0/AN5/SEG18	18	I/O I O	ST Analog Analog	PORTF is a bidirectional I/O port.
RF0				Digital I/O.
AN5 SEG18				Analog input 5. SEG18 output for LCD.
RF1/AN6/C2OUT/SEG19	17	I/O I O O	ST Analog — Analog	Digital I/O.
RF1				Analog input 6.
AN6				Comparator 2 output.
C2OUT SEG19				SEG19 output for LCD.
RF2/AN7/C1OUT/SEG20	16	I/O I O O	ST Analog — Analog	Digital I/O.
RF2				Analog input 7.
AN7				Comparator 1 output.
C1OUT SEG20				SEG20 output for LCD.
RF3/AN8/SEG21	15	I/O I O	ST Analog Analog	Digital I/O.
RF3				Analog input 8.
AN8 SEG21				SEG21 output for LCD.
RF4/AN9/SEG22	14	I/O I O	ST Analog Analog	Digital I/O.
RF4				Analog input 9.
AN9 SEG22				SEG22 output for LCD.
RF5/AN10/CVREF/SEG23	13	I/O I O O	ST Analog Analog Analog	Digital I/O.
RF5				Analog input 10.
AN10				Comparator reference voltage output.
CVREF SEG23				SEG23 output for LCD.
RF6/AN11/SEG24	12	I/O I O	ST Analog Analog	Digital I/O.
RF6				Analog input 11.
AN11 SEG24				SEG24 output for LCD.
RF7/ \overline{SS} /SEG25	11	I/O I O	ST TTL Analog	Digital I/O.
RF7				SPI™ slave select input.
\overline{SS}				
SEG25				SEG25 output for LCD.

Legend: TTL = TTL compatible input CMOS = CMOS compatible input or output
 ST = Schmitt Trigger input with CMOS levels Analog = Analog input
 I = Input O = Output
 P = Power I²C = ST with I²C™ or SMB levels

Note 1: Default assignment for CCP2 when Configuration bit, CCP2MX, is set.
2: Alternate assignment for CCP2 when Configuration bit, CCP2MX, is cleared.

PIC18F6393/6493/8393/8493

TABLE 1-3: PIC18F8X93 PINOUT I/O DESCRIPTIONS (CONTINUED)

Pin Name	Pin Number	Pin Type	Buffer Type	Description
	TQFP			
RB0/INT0 RB0 INT0	58	I/O I	TTL ST	PORTB is a bidirectional I/O port. PORTB can be software programmed for internal weak pull-ups on all inputs. Digital I/O. External interrupt 0.
RB1/INT1/SEG8 RB1 INT1 SEG8	57	I/O I O	TTL ST Analog	Digital I/O. External interrupt 1. SEG8 output for LCD.
RB2/INT2/SEG9 RB2 INT2 SEG9	56	I/O I O	TTL ST Analog	Digital I/O. External interrupt 2. SEG9 output for LCD.
RB3/INT3/SEG10 RB3 INT3 SEG10	55	I/O I O	TTL ST Analog	Digital I/O. External interrupt 3. SEG10 output for LCD.
RB4/KBI0/SEG11 RB4 KBI0 SEG11	54	I/O I O	TTL TTL Analog	Digital I/O. Interrupt-on-change pin. SEG11 output for LCD.
RB5/KBI1 RB5 KBI1	53	I/O I	TTL TTL	Digital I/O. Interrupt-on-change pin.
RB6/KBI2/PGC RB6 KBI2 PGC	52	I/O I I/O	TTL TTL ST	Digital I/O. Interrupt-on-change pin. In-Circuit Debugger and ICSP™ programming clock pin.
RB7/KBI3/PGD RB7 KBI3 PGD	47	I/O I I/O	TTL TTL ST	Digital I/O. Interrupt-on-change pin. In-Circuit Debugger and ICSP programming data pin.

Legend: TTL = TTL compatible input CMOS = CMOS compatible input or output
ST = Schmitt Trigger input with CMOS levels Analog = Analog input
I = Input O = Output
P = Power I²C = ST with I²C™ or SMB levels

- Note 1:** Default assignment for CCP2 when Configuration bit, CCP2MX, is set.
2: Alternate assignment for CCP2 when Configuration bit, CCP2MX, is cleared.

PIC18F6393/6493/8393/8493

TABLE 1-3: PIC18F8X93 PINOUT I/O DESCRIPTIONS (CONTINUED)

Pin Name	Pin Number	Pin Type	Buffer Type	Description
	TQFP			
RC0/T1OSO/T13CKI	36			PORTC is a bidirectional I/O port.
RC0		I/O	ST	Digital I/O.
T1OSO		O	—	Timer1 oscillator output.
T13CKI		I	ST	Timer1/Timer3 external clock input.
RC1/T1OSI/CCP2	35			
RC1		I/O	ST	Digital I/O.
T1OSI		I	CMOS	Timer1 oscillator input.
CCP2 ⁽¹⁾		I/O	ST	Capture 2 input/Compare 2 output/PWM2 output.
RC2/CCP1/SEG13	43			
RC2		I/O	ST	Digital I/O.
CCP1		I/O	ST	Capture 1 input/Compare 1 output/PWM1 output.
SEG13		O	Analog	SEG13 output for LCD.
RC3/SCK/SCL	44			
RC3		I/O	ST	Digital I/O.
SCK		I/O	ST	Synchronous serial clock input/output for SPI mode.
SCL		I/O	I ² C	Synchronous serial clock input/output for I ² C™ mode.
RC4/SDI/SDA	45			
RC4		I/O	ST	Digital I/O.
SDI		I	ST	SPI data in.
SDA		I/O	I ² C	I ² C data I/O.
RC5/SDO/SEG12	46			
RC5		I/O	ST	Digital I/O.
SDO		O	—	SPI data out.
SEG12		O	Analog	SEG12 output for LCD.
RC6/TX1/CK1	37			
RC6		I/O	ST	Digital I/O.
TX1		O	—	EUSART1 asynchronous transmit.
CK1		I/O	ST	EUSART1 synchronous clock (see related RX1/DT1).
RC7/RX1/DT1	38			
RC7		I/O	ST	Digital I/O.
RX1		I	ST	EUSART1 asynchronous receive.
DT1		I/O	ST	EUSART1 synchronous data (see related TX1/CK1).

Legend: TTL = TTL compatible input CMOS = CMOS compatible input or output
ST = Schmitt Trigger input with CMOS levels Analog = Analog input
I = Input O = Output
P = Power I²C = ST with I²C™ or SMB levels

Note 1: Default assignment for CCP2 when Configuration bit, CCP2MX, is set.
2: Alternate assignment for CCP2 when Configuration bit, CCP2MX, is cleared.

PIC18F6393/6493/8393/8493

TABLE 1-3: PIC18F8X93 PINOUT I/O DESCRIPTIONS (CONTINUED)

Pin Name	Pin Number	Pin Type	Buffer Type	Description
	TQFP			
RD0/SEG0 RD0 SEG0	72	I/O O	ST Analog	PORTD is a bidirectional I/O port. Digital I/O. SEG0 output for LCD.
RD1/SEG1 RD1 SEG1	69	I/O O	ST Analog	Digital I/O. SEG1 output for LCD.
RD2/SEG2 RD2 SEG2	68	I/O O	ST Analog	Digital I/O. SEG2 output for LCD.
RD3/SEG3 RD3 SEG3	67	I/O O	ST Analog	Digital I/O. SEG3 output for LCD.
RD4/SEG4 RD4 SEG4	66	I/O O	ST Analog	Digital I/O. SEG4 output for LCD.
RD5/SEG5 RD5 SEG5	65	I/O O	ST Analog	Digital I/O. SEG5 output for LCD.
RD6/SEG6 RD6 SEG6	64	I/O O	ST Analog	Digital I/O. SEG6 output for LCD.
RD7/SEG7 RD7 SEG7	63	I/O O	ST Analog	Digital I/O. SEG7 output for LCD.

Legend: TTL = TTL compatible input CMOS = CMOS compatible input or output
 ST = Schmitt Trigger input with CMOS levels Analog = Analog input
 I = Input O = Output
 P = Power I²C = ST with I²C™ or SMB levels

Note 1: Default assignment for CCP2 when Configuration bit, CCP2MX, is set.

2: Alternate assignment for CCP2 when Configuration bit, CCP2MX, is cleared.

PIC18F6393/6493/8393/8493

TABLE 1-3: PIC18F8X93 PINOUT I/O DESCRIPTIONS (CONTINUED)

Pin Name	Pin Number	Pin Type	Buffer Type	Description
	TQFP			
LCDBIAS1 LCDBIAS1	4	I	Analog	BIAS1 input for LCD.
LCDBIAS2 LCDBIAS2	3	I	Analog	BIAS2 input for LCD.
LCDBIAS3 LCDBIAS3	78	I	Analog	BIAS3 input for LCD.
COM0 COM0	77	O	Analog	COM0 output for LCD.
RE4/COM1 RE4 COM1	76	I/O O	ST Analog	Digital I/O. COM1 output for LCD.
RE5/COM2 RE5 COM2	75	I/O O	ST Analog	Digital I/O. COM2 output for LCD.
RE6/COM3 RE6 COM3	74	I/O O	ST Analog	Digital I/O. COM3 output for LCD.
RE7/CCP2/SEG31 RE7 CCP2 ⁽²⁾ SEG31	73	I/O I/O O	ST ST Analog	Digital I/O. Capture 2 input/Compare 2 output/PWM2 output. SEG31 output for LCD.

Legend: TTL = TTL compatible input CMOS = CMOS compatible input or output
 ST = Schmitt Trigger input with CMOS levels Analog = Analog input
 I = Input O = Output
 P = Power I²C = ST with I²C™ or SMB levels

Note 1: Default assignment for CCP2 when Configuration bit, CCP2MX, is set.
2: Alternate assignment for CCP2 when Configuration bit, CCP2MX, is cleared.

PIC18F6393/6493/8393/8493

TABLE 1-3: PIC18F8X93 PINOUT I/O DESCRIPTIONS (CONTINUED)

Pin Name	Pin Number	Pin Type	Buffer Type	Description
	TQFP			
RF0/AN5/SEG18	24	I/O	ST	PORTF is a bidirectional I/O port. Digital I/O. Analog Input 5. SEG18 output for LCD.
RF0		I	Analog	
AN5		O	Analog	
SEG18		O	Analog	
RF1/AN6/C2OUT/SEG19	23	I/O	ST	Digital I/O. Analog Input 6. Comparator 2 output. SEG19 output for LCD.
RF1		I	Analog	
AN6		O	—	
C2OUT		O	Analog	
SEG19		O	Analog	
RF2/AN7/C1OUT/SEG20	18	I/O	ST	Digital I/O. Analog Input 7. Comparator 1 output. SEG20 output for LCD.
RF2		I	Analog	
AN7		O	—	
C1OUT		O	Analog	
SEG20		O	Analog	
RF3/AN8/SEG21	17	I/O	ST	Digital I/O. Analog Input 8. SEG21 output for LCD.
RF3		I	Analog	
AN8		O	Analog	
SEG21		O	Analog	
RF4/AN9/SEG22	16	I/O	ST	Digital I/O. Analog Input 9. SEG22 output for LCD.
RF4		I	Analog	
AN9		O	Analog	
SEG22		O	Analog	
RF5/AN10/CVREF/SEG23	15	I/O	ST	Digital I/O. Analog Input 10. Comparator reference voltage output. SEG23 output for LCD.
RF5		I	Analog	
AN10		O	Analog	
CVREF		O	Analog	
SEG23		O	Analog	
RF6/AN11/SEG24	14	I/O	ST	Digital I/O. Analog Input 11. SEG24 output for LCD.
RF6		I	Analog	
AN11		O	Analog	
SEG24		O	Analog	
RF7/ \overline{SS} /SEG25	13	I/O	ST	Digital I/O. SPI slave select input. SEG25 output for LCD.
RF7		I	TTL	
\overline{SS}		O	Analog	
SEG25		O	Analog	

Legend: TTL = TTL compatible input CMOS = CMOS compatible input or output
ST = Schmitt Trigger input with CMOS levels Analog = Analog input
I = Input O = Output
P = Power I²C = ST with I²C™ or SMB levels

Note 1: Default assignment for CCP2 when Configuration bit, CCP2MX, is set.
2: Alternate assignment for CCP2 when Configuration bit, CCP2MX, is cleared.

PIC18F6393/6493/8393/8493

TABLE 1-3: PIC18F8X93 PINOUT I/O DESCRIPTIONS (CONTINUED)

Pin Name	Pin Number	Pin Type	Buffer Type	Description
	TQFP			
RG0/SEG30 RG0 SEG30	5	I/O O	ST Analog	PORTG is a bidirectional I/O port. Digital I/O. SEG30 output for LCD.
RG1/TX2/CK2/SEG29 RG1 TX2 CK2 SEG29	6	I/O O I/O O	ST — ST Analog	Digital I/O. AUSART2 asynchronous transmit. AUSART2 synchronous clock (see related RX2/DT2). SEG29 output for LCD.
RG2/RX2/DT2/SEG28 RG2 RX2 DT2 SEG28	7	I/O I I/O O	ST ST ST Analog	Digital I/O. AUSART2 asynchronous receive. AUSART2 synchronous data (see related TX2/CK2). SEG28 output for LCD.
RG3/SEG27 RG3 SEG27	8	I/O O	ST Analog	Digital I/O. SEG27 output for LCD.
RG4/SEG26 RG4 SEG26	10	I/O O	ST Analog	Digital I/O. SEG26 output for LCD.
RG5				See $\overline{\text{MCLR}}/\text{VPP}/\text{RG5}$ pin.

Legend: TTL = TTL compatible input CMOS = CMOS compatible input or output
 ST = Schmitt Trigger input with CMOS levels Analog = Analog input
 I = Input O = Output
 P = Power I²C = ST with I²C™ or SMB levels

Note 1: Default assignment for CCP2 when Configuration bit, CCP2MX, is set.
2: Alternate assignment for CCP2 when Configuration bit, CCP2MX, is cleared.

PIC18F6393/6493/8393/8493

2.0 12-BIT ANALOG-TO-DIGITAL CONVERTER (A/D) MODULE

The Analog-to-Digital (A/D) Converter module converts an analog input signal to a 12-bit digital number. The module has 12 inputs for both PIC18F6393/6493 (64-pin) and PIC18F8393/8493 (80-pin) devices.

The module has five registers:

- A/D Result High Register (ADRESH)
- A/D Result Low Register (ADRESL)
- A/D Control Register 0 (ADCON0)
- A/D Control Register 1 (ADCON1)
- A/D Control Register 2 (ADCON2)

The ADCON0 register, shown in Register 2-1, controls the operation of the A/D module. The ADCON1 register, shown in Register 2-2, configures the functions of the port pins. The ADCON2 register, shown in Register 2-3, configures the A/D clock source, programmed acquisition time and justification.

REGISTER 2-1: ADCON0: A/D CONTROL REGISTER 0

U-0	U-0	R/W-0	R/W-0	R/W-0	R/W-0	R/W-0	R/W-0
—	—	CHS3	CHS2	CHS1	CHS0	GO/DONE	ADON
bit 7						bit 0	

Legend:

R = Readable bit
-n = Value at POR

W = Writable bit
'1' = Bit is set

U = Unimplemented bit, read as '0'
'0' = Bit is cleared
x = Bit is unknown

- bit 7-6 **Unimplemented:** Read as '0'
- bit 5-2 **CHS<3:0>:** Analog Channel Select bits
- 0000 = Channel 0 (AN0)
 - 0001 = Channel 1 (AN1)
 - 0010 = Channel 2 (AN2)
 - 0011 = Channel 3 (AN3)
 - 0100 = Channel 4 (AN4)
 - 0101 = Channel 5 (AN5)
 - 0110 = Channel 6 (AN6)
 - 0111 = Channel 7 (AN7)
 - 1000 = Channel 8 (AN8)
 - 1001 = Channel 9 (AN9)
 - 1010 = Channel 10 (AN10)
 - 1011 = Channel 11 (AN11)
 - 1100 = Unimplemented⁽¹⁾
 - 1101 = Unimplemented⁽¹⁾
 - 1110 = Unimplemented⁽¹⁾
 - 1111 = Unimplemented⁽¹⁾
- bit 1 **GO/DONE:** A/D Conversion Status bit
- When ADON = 1:
- 1 = A/D conversion in progress
 - 0 = A/D Idle
- bit 0 **ADON:** A/D On bit
- 1 = A/D Converter module is enabled
 - 0 = A/D Converter module is disabled

Note 1: Performing a conversion on unimplemented channels will return a floating input measurement.

PIC18F6393/6493/8393/8493

REGISTER 2-2: ADCON1: A/D CONTROL REGISTER 1

U-0	U-0	R/W-0	R/W-0	R/W-0	R/W-0	R/W-0	R/W-0
—	—	VCFG1	VCFG0	PCFG3	PCFG2	PCFG1	PCFG0
bit 7							bit 0

Legend:

R = Readable bit W = Writable bit U = Unimplemented bit, read as '0'
 -n = Value at POR '1' = Bit is set '0' = Bit is cleared x = Bit is unknown

bit 7-6 **Unimplemented:** Read as '0'

bit 5-4 **VCFG<1:0>:** Voltage Reference Configuration bits

	A/D VREF+	A/D VREF-
00	AVDD	AVSS
01	External VREF+	AVSS
10	AVDD	External VREF-
11	External VREF+	External VREF-

bit 3-0 **PCFG<3:0>:** A/D Port Configuration Control bits

PCFG<3:0>	AN11	AN10	AN9	AN8	AN7	AN6	AN5	AN4	AN3	AN2	AN1	AN0
0000	A	A	A	A	A	A	A	A	A	A	A	A
0001	A	A	A	A	A	A	A	A	A	A	A	A
0010	A	A	A	A	A	A	A	A	A	A	A	A
0011	A	A	A	A	A	A	A	A	A	A	A	A
0100	D	A	A	A	A	A	A	A	A	A	A	A
0101	D	D	A	A	A	A	A	A	A	A	A	A
0110	D	D	D	A	A	A	A	A	A	A	A	A
0111	D	D	D	D	A	A	A	A	A	A	A	A
1000	D	D	D	D	D	A	A	A	A	A	A	A
1001	D	D	D	D	D	D	A	A	A	A	A	A
1010	D	D	D	D	D	D	D	A	A	A	A	A
1011	D	D	D	D	D	D	D	D	A	A	A	A
1100	D	D	D	D	D	D	D	D	D	A	A	A
1101	D	D	D	D	D	D	D	D	D	D	A	A
1110	D	D	D	D	D	D	D	D	D	D	D	A
1111	D	D	D	D	D	D	D	D	D	D	D	D

A = Analog input

D = Digital I/O

PIC18F6393/6493/8393/8493

REGISTER 2-3: ADCON2: A/D CONTROL REGISTER 2

R/W-0	U-0	R/W-0	R/W-0	R/W-0	R/W-0	R/W-0	R/W-0
ADFM	—	ACQT2	ACQT1	ACQT0	ADCS2	ADCS1	ADCS0
bit 7							bit 0

Legend:

R = Readable bit W = Writable bit U = Unimplemented bit, read as '0'
 -n = Value at POR '1' = Bit is set '0' = Bit is cleared x = Bit is unknown

- bit 7 **ADFM:** A/D Result Format Select bit
 1 = Right justified
 0 = Left justified
- bit 6 **Unimplemented:** Read as '0'
- bit 5-3 **ACQT<2:0>:** A/D Acquisition Time Select bits
 111 = 20 TAD
 110 = 16 TAD
 101 = 12 TAD
 100 = 8 TAD
 011 = 6 TAD
 010 = 4 TAD
 001 = 2 TAD
 000 = 0 TAD⁽¹⁾
- bit 2-0 **ADCS<2:0>:** A/D Conversion Clock Select bits
 111 = FRC (clock derived from A/D RC oscillator)⁽¹⁾
 110 = FOSC/64
 101 = FOSC/16
 100 = FOSC/4
 011 = FRC (clock derived from A/D RC oscillator)⁽¹⁾
 010 = FOSC/32
 001 = FOSC/8
 000 = FOSC/2

Note 1: If the A/D FRC clock source is selected, a delay of one T_{CY} (instruction cycle) is added before the A/D clock starts. This allows the SLEEP instruction to be executed before starting a conversion.

PIC18F6393/6493/8393/8493

The analog reference voltage is software-selectable to either the device's positive and negative supply voltage (AVDD and AVSS), or the voltage level on the RA3/AN3/VREF+/SEG17 and RA2/AN2/VREF-/SEG16 pins.

The A/D Converter has a unique feature of being able to operate while the device is in Sleep mode. To operate in Sleep, the A/D conversion clock must be derived from the A/D's internal RC oscillator.

The output of the sample and hold is the input into the converter, which generates the result via successive approximation.

A device Reset forces all registers to their Reset state. This forces the A/D module to be turned off and any conversion in progress is aborted.

Each port pin associated with the A/D Converter can be configured as an analog input or a digital I/O. The ADRESH and ADRESL registers contain the result of the A/D conversion. When the A/D conversion is complete, the result is loaded into the ADRESH:ADRESL register pair, the GO/DONE bit (ADCON0<1>) is cleared and the A/D Interrupt Flag bit, ADIF, is set. The block diagram of the A/D module is shown in Figure 2-1.

FIGURE 2-1: A/D BLOCK DIAGRAM

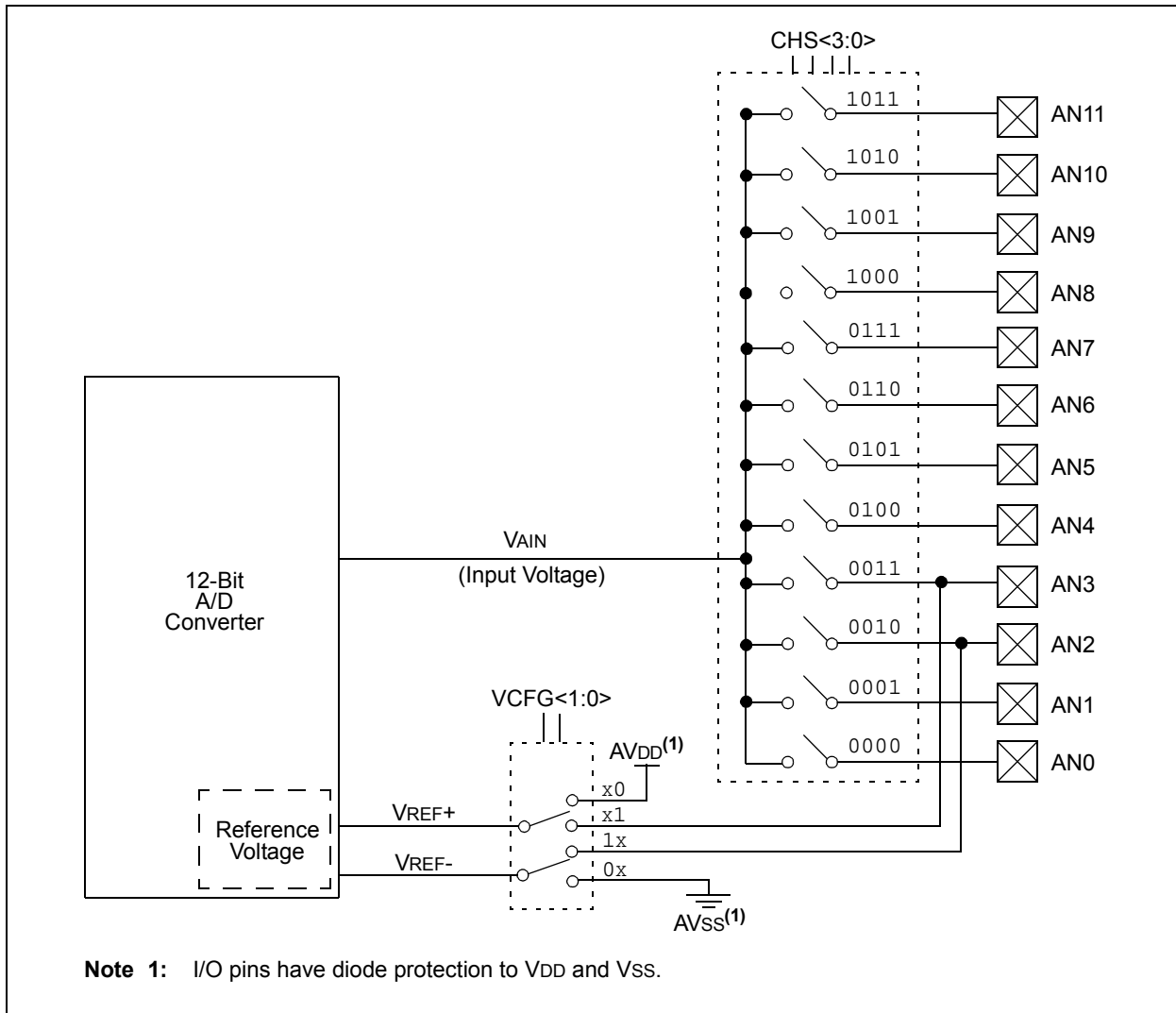

PIC18F6393/6493/8393/8493

The value in the ADRESH:ADRESL registers is unknown following Power-on and Brown-out Resets and is not affected by any other Reset.

After the A/D module has been configured as desired, the selected channel must be acquired before the conversion is started. The analog input channels must have their corresponding TRIS bits selected as an input. To determine acquisition time, see **Section 2.1 “A/D Acquisition Requirements”**. After this acquisition time has elapsed, the A/D conversion can be started. An acquisition time can be programmed to occur between setting the GO/DONE bit and the actual start of the conversion.

The following steps should be followed to perform an A/D conversion:

1. Configure the A/D module:
 - Configure analog pins, voltage reference and digital I/O (ADCON1)
 - Select A/D input channel (ADCON0)
 - Select A/D acquisition time (ADCON2)
 - Select A/D conversion clock (ADCON2)
 - Turn on A/D module (ADCON0)
2. Configure A/D interrupt (if desired):
 - Clear ADIF bit
 - Set ADIE bit
 - Set GIE bit
3. Wait the required acquisition time (if required).
4. Start conversion:
 - Set GO/DONE bit (ADCON0<1>)

5. Wait for A/D conversion to complete by either:
 - Polling for the GO/DONE bit to be cleared
 - OR
 - Waiting for the A/D interrupt
6. Read A/D Result registers (ADRESH:ADRESL); clear bit, ADIF, if required.
7. For the next conversion, go to Step 1 or Step 2, as required. The A/D conversion time per bit is defined as TAD. A minimum wait of 2 TAD is required before the next acquisition starts.

FIGURE 2-2: A/D TRANSFER FUNCTION

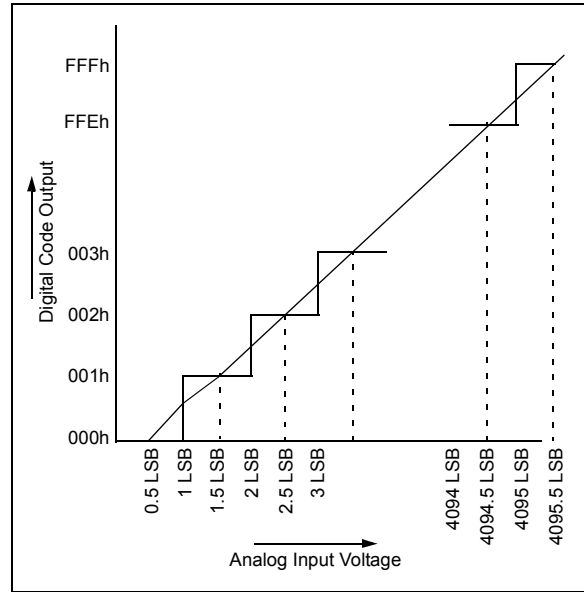
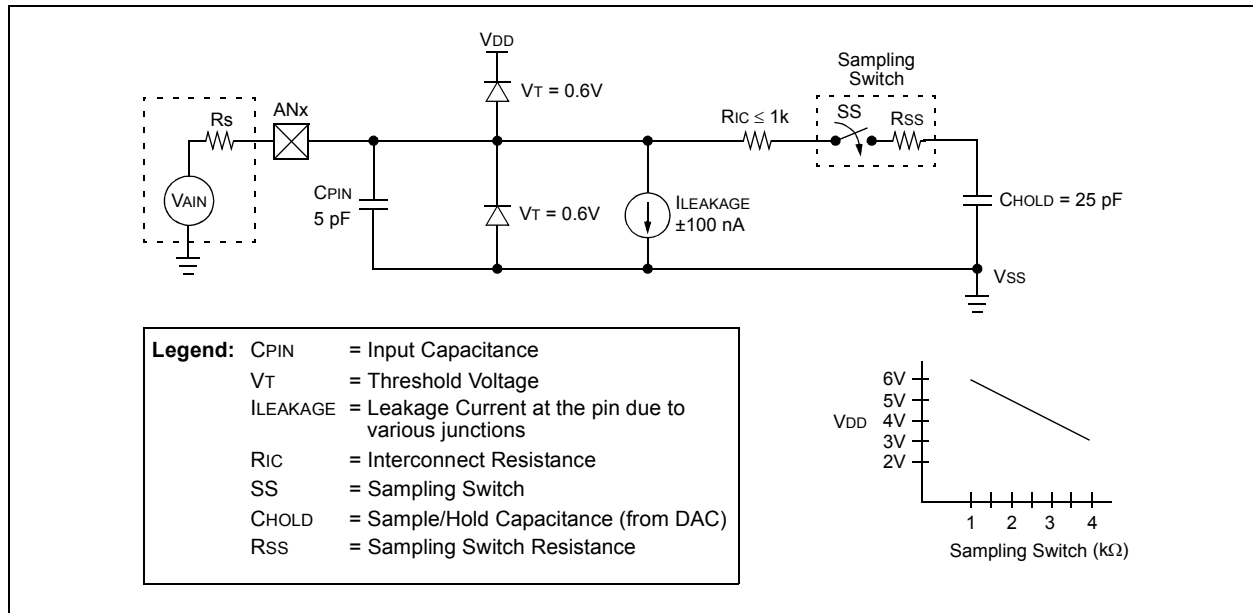

FIGURE 2-3: ANALOG INPUT MODEL



PIC18F6393/6493/8393/8493

2.1 A/D Acquisition Requirements

For the A/D Converter to meet its specified accuracy, the charge holding capacitor (CHOLD) must be allowed to fully charge to the input channel voltage level. The analog input model is shown in Figure 2-3. The source impedance (Rs) and the internal sampling switch (Rss) impedance directly affect the time required to charge the capacitor, CHOLD. The sampling switch (Rss) impedance varies over the device voltage (VDD). The source impedance affects the offset voltage at the analog input (due to pin leakage current). **The maximum recommended impedance for analog sources is 2.5 kΩ.** After the analog input channel is selected (changed), the channel must be sampled for at least the minimum acquisition time before starting a conversion.

Note: When the conversion is started, the holding capacitor is disconnected from the input pin.

To calculate the minimum acquisition time, Equation 2-1 may be used. This equation assumes that 1/2 LSB error is used (4096 steps for the 12-bit A/D). The 1/2 LSB error is the maximum error allowed for the A/D to meet its specified resolution.

Equation 2-3 shows the calculation of the minimum required acquisition time, TACQ. This calculation is based on the following application system assumptions:

CHOLD	=	25 pF
Rs	=	2.5 kΩ
Conversion Error	≤	1/2 LSB
VDD	=	3V → Rss = 4 kΩ
Temperature	=	85°C (system max.)

EQUATION 2-1: A/D ACQUISITION TIME

$$\begin{aligned}TACQ &= \text{Amplifier Settling Time} + \text{Holding Capacitor Charging Time} + \text{Temperature Coefficient} \\ &= TAMP + TC + TCOFF\end{aligned}$$

EQUATION 2-2: A/D MINIMUM CHARGING TIME

$$\begin{aligned}V_{HOLD} &= (V_{REF} - (V_{REF}/4096)) \cdot (1 - e^{-(Tc/CHOLD)(R_{IC} + R_{SS} + R_s)}) \\ \text{or} \\ Tc &= (CHOLD)(R_{IC} + R_{SS} + R_s) \ln(1/4096)\end{aligned}$$

EQUATION 2-3: CALCULATING THE MINIMUM REQUIRED ACQUISITION TIME

$$TACQ = TAMP + TC + TCOFF$$

$$TAMP = 0.2 \mu s$$

$$\begin{aligned}TCOFF &= (\text{Temp} - 25^\circ\text{C})(0.02 \mu s/^\circ\text{C}) \\ &= (85^\circ\text{C} - 25^\circ\text{C})(0.02 \mu s/^\circ\text{C}) \\ &= 1.2 \mu s\end{aligned}$$

Temperature coefficient is only required for temperatures > 25°C. Below 25°C, TCOFF = 0 μs.

$$\begin{aligned}Tc &= -(CHOLD)(R_{IC} + R_{SS} + R_s) \ln(1/4096) \mu s \\ &= -(25 \text{ pF})(1 \text{ k}\Omega + 4 \text{ k}\Omega + 2.5 \text{ k}\Omega) \ln(0.0002441) \mu s \\ &= 1.56 \mu s\end{aligned}$$

$$\begin{aligned}TACQ &= 0.2 \mu s + 1.56 \mu s + 1.2 \mu s \\ &= 2.96 \mu s\end{aligned}$$

2.2 Selecting and Configuring Acquisition Time

The ADCON2 register allows the user to select an acquisition time that occurs each time the GO/DONE bit is set. It also gives users the option to use an automatically determined acquisition time.

Acquisition time may be set with the ACQT<2:0> bits (ADCON2<5:3>), which provide a range of 2 to 20 TAD. When the GO/DONE bit is set, the A/D module continues to sample the input for the selected acquisition time, then automatically begins a conversion. Since the acquisition time is programmed, there may be no need to wait for an acquisition time between selecting a channel and setting the GO/DONE bit.

Manual acquisition is selected when ACQT<2:0> = 000. When the GO/DONE bit is set, sampling is stopped and a conversion begins. The user is responsible for ensuring the required acquisition time has passed between selecting the desired input channel and setting the GO/DONE bit. This option is also the default Reset state of the ACQT<2:0> bits and is compatible with devices that do not offer programmable acquisition times.

In either case, when the conversion is completed, the GO/DONE bit is cleared, the ADIF flag is set and the A/D begins sampling the currently selected channel again. If an acquisition time is programmed, there is nothing to indicate if the acquisition time has ended or if the conversion has begun.

2.3 Selecting the A/D Conversion Clock

The A/D conversion time per bit is defined as TAD. The A/D conversion requires 13 TAD per 12-bit conversion. The source of the A/D conversion clock is software-selectable. There are seven possible options for TAD:

- 2 TOSC
- 4 TOSC
- 8 TOSC
- 16 TOSC
- 32 TOSC
- 64 TOSC
- Internal RC Oscillator

For correct A/D conversions, the A/D conversion clock (TAD) must be as short as possible, but greater than the minimum TAD. (See parameter 130 for more information.)

Table 2-1 shows the resultant TAD times derived from the device operating frequencies and the A/D clock source selected.

TABLE 2-1: TAD vs. DEVICE OPERATING FREQUENCIES

A/D Clock Source (TAD)		Assumes TAD Min. = 0.8 μs
Operation	ADCS<2:0>	Maximum Fosc
2 TOSC	000	2.5 MHz
4 TOSC	100	5 MHz
8 TOSC	001	10 MHz
16 TOSC	101	20 MHz
32 TOSC	010	40 MHz
64 TOSC	110	40 MHz
RC ⁽¹⁾	x11	1 MHz ⁽²⁾

Note 1: The RC source has a typical TAD time of 2.5 μs.

2: For device frequencies above 1 MHz, the device must be in Sleep for the entire conversion or a Fosc divider should be used instead; otherwise, the A/D accuracy specification may not be met.

2.4 Operation in Power-Managed Modes

If the A/D is expected to operate while the device is in a power-managed mode, the ACQT<2:0> and ADCS<2:0> bits in ADCON2 should be updated in accordance with the clock source to be used in that mode. After entering the mode, an A/D acquisition or conversion may be started. Once started, the device should continue to be clocked by the same clock source until the conversion has been completed.

If desired, the device may be placed into the corresponding Idle mode during the conversion. If the device clock frequency is less than 1 MHz, the A/D RC clock source should be selected.

Operation in Sleep mode requires the A/D FRC clock to be selected. If bits, ACQT<2:0>, are set to '000' and a conversion is started, the conversion will be delayed one instruction cycle to allow execution of the SLEEP instruction, and entry to Sleep mode. The IDLEN bit (OSCCON<7>) must have already been cleared prior to starting the conversion.

2.5 Configuring Analog Port Pins

The ADCON1, TRISA, TRISF and TRISH registers all configure the A/D port pins. The port pins needed as analog inputs must have their corresponding TRIS bits set (input). If the TRIS bit is cleared (output), the digital output level (VOH or VOL) will be converted.

The A/D operation is independent of the state of the CHS<3:0> bits and the TRIS bits.

Note 1: When reading the PORT register, all pins configured as analog input channels will read as cleared (a low level). Analog conversion on pins configured as digital pins can be performed. The voltage on the pin will be accurately converted.

2: Analog levels on any pin defined as a digital input may cause the digital input buffer to consume current out of the device's specification limits.

2.6 A/D Conversions

Figure 2-4 shows the operation of the A/D Converter after the $\overline{\text{GO/DONE}}$ bit has been set and the $\text{ACQT}<2:0>$ bits are cleared. A conversion is started after the following instruction to allow entry into Sleep mode before the conversion begins.

Figure 2-5 shows the operation of the A/D Converter after the $\overline{\text{GO/DONE}}$ bit has been set, the $\text{ACQT}<2:0>$ bits are set to '010' and a 4 TAD acquisition time has been selected before the conversion starts.

Clearing the $\overline{\text{GO/DONE}}$ bit during a conversion will abort the current conversion. The A/D Result register pair will *not* be updated with the partially completed A/D conversion sample. This means the ADRESH:ADRESL registers will continue to contain the value of the last completed conversion (or the last value written to the ADRESH:ADRESL registers).

After the A/D conversion is completed or aborted, a 2 TAD wait is required before the next acquisition can be started. After this wait, acquisition on the selected channel is automatically started.

Note: The $\overline{\text{GO/DONE}}$ bit should **NOT** be set in the same instruction that turns on the A/D. Code should wait at least 2 μs after enabling the A/D before beginning an acquisition and conversion cycle.

2.7 Discharge

The discharge phase is used to initialize the value of the holding capacitor. The array is discharged before every sample. This feature helps to optimize the unity gain amplifier, as the circuit always needs to charge the capacitor array, rather than charge/discharge based on previous measure values.

FIGURE 2-4: A/D CONVERSION TAD CYCLES ($\text{ACQT}<2:0> = 000, \text{TACQ} = 0$)

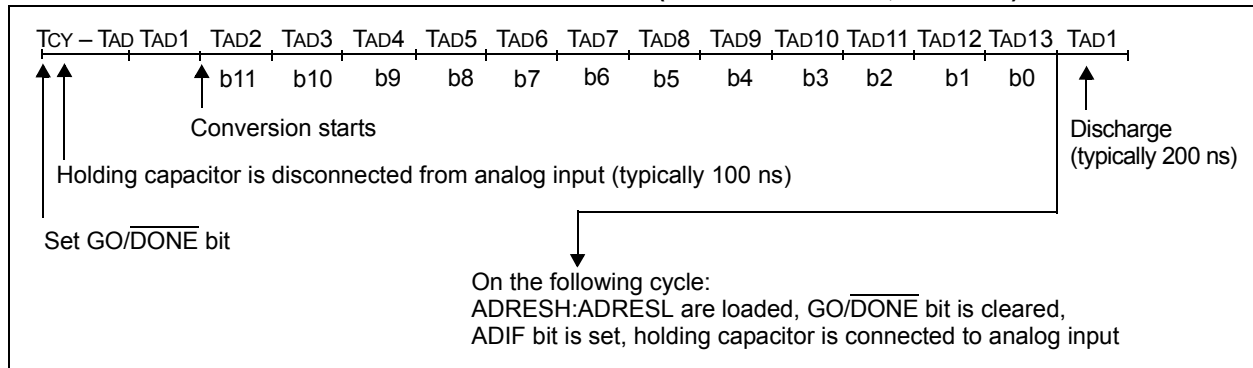
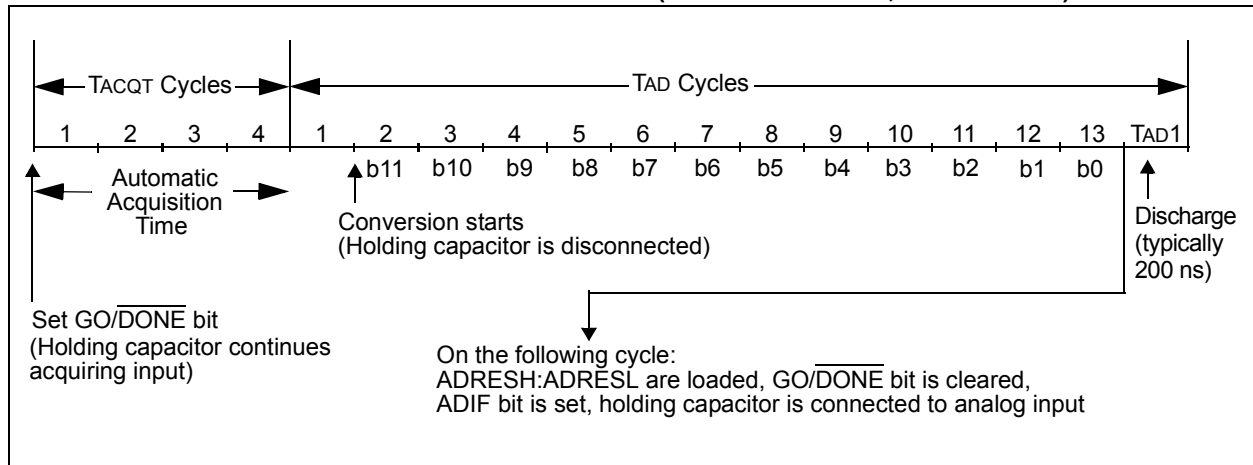

FIGURE 2-5: A/D CONVERSION TAD CYCLES ($\text{ACQT}<2:0> = 010, \text{TACQ} = 4 \text{TAD}$)



PIC18F6393/6493/8393/8493

2.8 Use of the ECCP2 Trigger

An A/D conversion can be started by the Special Event Trigger of the ECCP2 module. This requires that the CCP2M<3:0> bits (CCP2CON<3:0>) be programmed as '1011' and that the A/D module is enabled (ADON bit is set). When the trigger occurs, the GO/DONE bit will be set, starting the A/D acquisition and conversion, and the Timer1 (or Timer3) counter will be reset to zero. Timer1 (or Timer3) is reset to automatically repeat the A/D acquisition period with minimal software overhead (moving ADRESH:ADRESL to the desired location).

The appropriate analog input channel must be selected and the minimum acquisition period is either timed by the user, or an appropriate TACQ time selected before the Special Event Trigger sets the GO/DONE bit (starts a conversion).

If the A/D module is not enabled (ADON is cleared), the Special Event Trigger will be ignored by the A/D module, but will still reset the Timer1 (or Timer3) counter.

TABLE 2-2: REGISTERS ASSOCIATED WITH A/D OPERATION

Name	Bit 7	Bit 6	Bit 5	Bit 4	Bit 3	Bit 2	Bit 1	Bit 0	Reset Values
INTCON	GIE/GIEH	PEIE/GIEL	TMR0IE	INT0IE	RBIE	TMR0IF	INT0IF	RBIF	(3)
PIR1	—	ADIF	RC1IF	TX1IF	SSP1IF	CCP1IF	TMR2IF	TMR1IF	(3)
PIE1	—	ADIE	RC1IE	TX1IE	SSP1IE	CCP1IE	TMR2IE	TMR1IE	(3)
IPR1	—	ADIP	RC1IP	TX1IP	SSP1IP	CCP1IP	TMR2IP	TMR1IP	(3)
PIR2	OSCFIF	CMIF	—	—	BCL1IF	HLVDIF	TMR3IF	CCP2IF	(3)
PIE2	OSCFIE	CMIE	—	—	BCL1IE	HLVDIE	TMR3IE	CCP2IE	(3)
IPR2	OSCFIP	CMIP	—	—	BCL1IP	HLVDIP	TMR3IP	CCP2IP	(3)
ADRESH	A/D Result Register High Byte								(3)
ADRESL	A/D Result Register Low Byte								(3)
ADCON0	—	—	CHS3	CHS2	CHS1	CHS0	GO/DONE	ADON	(3)
ADCON1	—	—	VCFG1	VCFG0	PCFG3	PCFG2	PCFG1	PCFG0	(3)
ADCON2	ADFM	—	ACQT2	ACQT1	ACQT0	ADCS2	ADCS1	ADCS0	(3)
TRISA	TRISA7 ⁽¹⁾	TRISA6 ⁽¹⁾	TRISA5	TRISA4	TRISA3	TRISA2	TRISA1	TRISA0	(3)
TRISF	TRISF7	TRISF6	TRISF5	TRISF4	TRISF3	TRISF2	TRISF1	TRISF0	(3)
TRISH ⁽²⁾	TRISH7	TRISH6	TRISH5	TRISH4	TRISH3	TRISH2	TRISH1	TRISH0	(3)

Legend: — = unimplemented, read as '0'. Shaded cells are not used for A/D conversion.

Note 1: PORTA<7:6> and their direction bits are individually configured as port pins based on various primary oscillator modes. When disabled, these bits read as '0'.

2: These registers are not implemented on 64-pin devices.

3: For these Reset values, see the "PIC18F6390/6490/8390/8490 Data Sheet" (DS39629).

PIC18F6393/6493/8393/8493

3.0 SPECIAL FEATURES OF THE CPU

Note: For additional details on the Configuration bits, refer to **Section 23.1 “Configuration Bits”** in the “PIC18F6390/6490/8390/8490 Data Sheet” (DS39629). Device ID information presented in this section is for the PIC18F6393/6493/8393/8493 devices only.

PIC18F6393/6493/8393/8493 devices include several features intended to maximize reliability and minimize cost through elimination of external components. These include:

- Device ID Registers

3.1 Device ID Registers

The Device ID registers are “read-only” registers. They identify the device type and revision to device programmers and can be read by firmware using table reads.

TABLE 3-1: DEVICE IDs

File Name	Bit 7	Bit 6	Bit 5	Bit 4	Bit 3	Bit 2	Bit 1	Bit 0	Default/ Unprogrammed Value
3FFFEh DEVID1	DEV2	DEV1	DEV0	REV4	REV3	REV2	REV1	REV0	xxxx xxxx ⁽¹⁾
3FFFFh DEVID2	DEV10	DEV9	DEV8	DEV7	DEV6	DEV5	DEV4	DEV3	xxxx xxxx ⁽¹⁾

Legend: x = unknown

Note 1: See Register 3-1 and Register 3-2 for DEVID values. DEVID registers are read-only and cannot be programmed by the user.

PIC18F6393/6493/8393/8493

REGISTER 3-1: DEVID1: DEVICE ID REGISTER 1 FOR PIC18F6393/6493/8393/8493 DEVICES

R	R	R	R	R	R	R	R
DEV2	DEV1	DEV0	REV4	REV3	REV2	REV1	REV0
bit 7							bit 0

Legend:

R = Read-only bit P = Programmable bit U = Unimplemented bit, read as '0'
 -n = Value when device is unprogrammed u = Unchanged from programmed state

bit 7-5 **DEV<2:0>**: Device ID bits
 See Register 3-2 for a complete listing.
 bit 4-0 **REV<4:0>**: Revision ID bits
 These bits are used to indicate the device revision.

REGISTER 3-2: DEVID2: DEVICE ID REGISTER 2 FOR PIC18F6393/6493/8393/8493 DEVICES

R	R	R	R	R	R	R	R
DEV10	DEV9	DEV8	DEV7	DEV6	DEV5	DEV4	DEV3
bit 7							bit 0

Legend:

R = Read-only bit P = Programmable bit U = Unimplemented bit, read as '0'
 -n = Value when device is unprogrammed u = Unchanged from programmed state

bit 7-0 **DEV10:DEV3**: Device ID bits

Device	DEV<10:3> (DEVID2<7:0>)	DEV<2:0> (DEVID1<7:5>)
PIC18F6393	0001 1010	000
PIC18F6493	0000 1110	000
PIC18F8393	0001 1010	001
PIC18F8493	0000 1110	001

PIC18F6393/6493/8393/8493

4.0 ELECTRICAL CHARACTERISTICS

Note: Other than some basic data, this section documents only the PIC18F6393/6493/8393/8493 devices' specifications that differ from those of the PIC18F6390/6490/8390/8490 devices. For detailed information on the electrical specifications shared by the PIC18F6393/6493/8393/8493 and PIC18F6390/6490/8390/8490 devices, see the "PIC18F6390/6490/8390/8490 Data Sheet" (DS39629).

Absolute Maximum Ratings^(†)

Ambient temperature under bias	-40°C to +125°C
Storage temperature	-65°C to +150°C
Voltage on any pin with respect to V _{SS} (except V _{DD} and $\overline{\text{MCLR}}$)	-0.3V to (V _{DD} + 0.3V)
Voltage on V _{DD} with respect to V _{SS}	-0.3V to +7.5V
Voltage on $\overline{\text{MCLR}}$ with respect to V _{SS} (Note 2)	0V to +13.25V
Total power dissipation (Note 1)	1.0W
Maximum current out of V _{SS} pin	300 mA
Maximum current into V _{DD} pin	250 mA
Input clamp current, I _{IK} (V _I < 0 or V _I > V _{DD})	±20 mA
Output clamp current, I _{OK} (V _O < 0 or V _O > V _{DD})	±20 mA
Maximum output current sunk by any I/O pin	25 mA
Maximum output current sourced by any I/O pin	25 mA
Maximum current sunk by all ports	200 mA
Maximum current sourced by all ports	200 mA

Note 1: Power dissipation is calculated as follows:

$$P_{DIS} = V_{DD} \times \{I_{DD} - \sum I_{OH}\} + \sum \{(V_{DD} - V_{OH}) \times I_{OH}\} + \sum (V_{OL} \times I_{OL})$$

2: Voltage spikes below V_{SS} at the $\overline{\text{MCLR}}$ /V_{PP}/RG5 pin, inducing currents greater than 80 mA, may cause latch-up. Thus, a series resistor of 50-100Ω should be used when applying a "low" level to the $\overline{\text{MCLR}}$ /V_{PP}/RG5 pin, rather than pulling this pin directly to V_{SS}.

† **NOTICE:** Stresses above those listed under "Absolute Maximum Ratings" may cause permanent damage to the device. This is a stress rating only and functional operation of the device at those or any other conditions above those indicated in the operation listings of this specification is not implied. Exposure to maximum rating conditions for extended periods may affect device reliability.

PIC18F6393/6493/8393/8493

FIGURE 4-1: PIC18F6393/6493/8393/8493 VOLTAGE-FREQUENCY GRAPH (INDUSTRIAL)

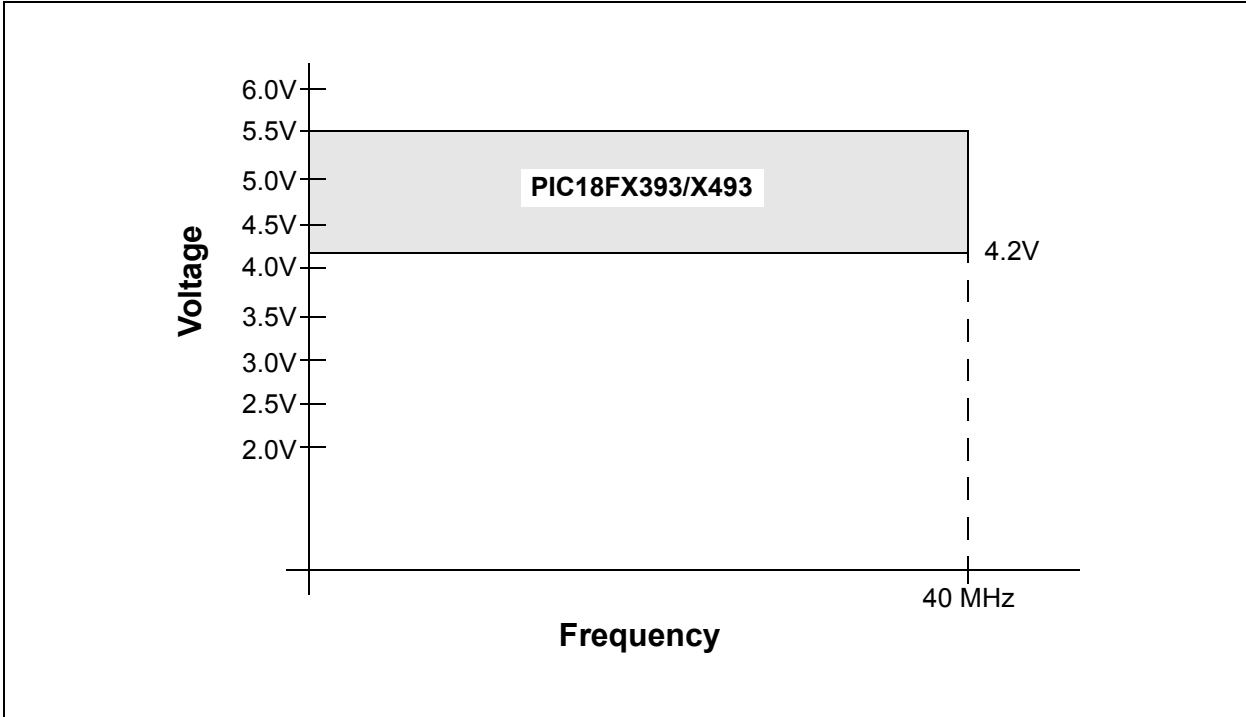
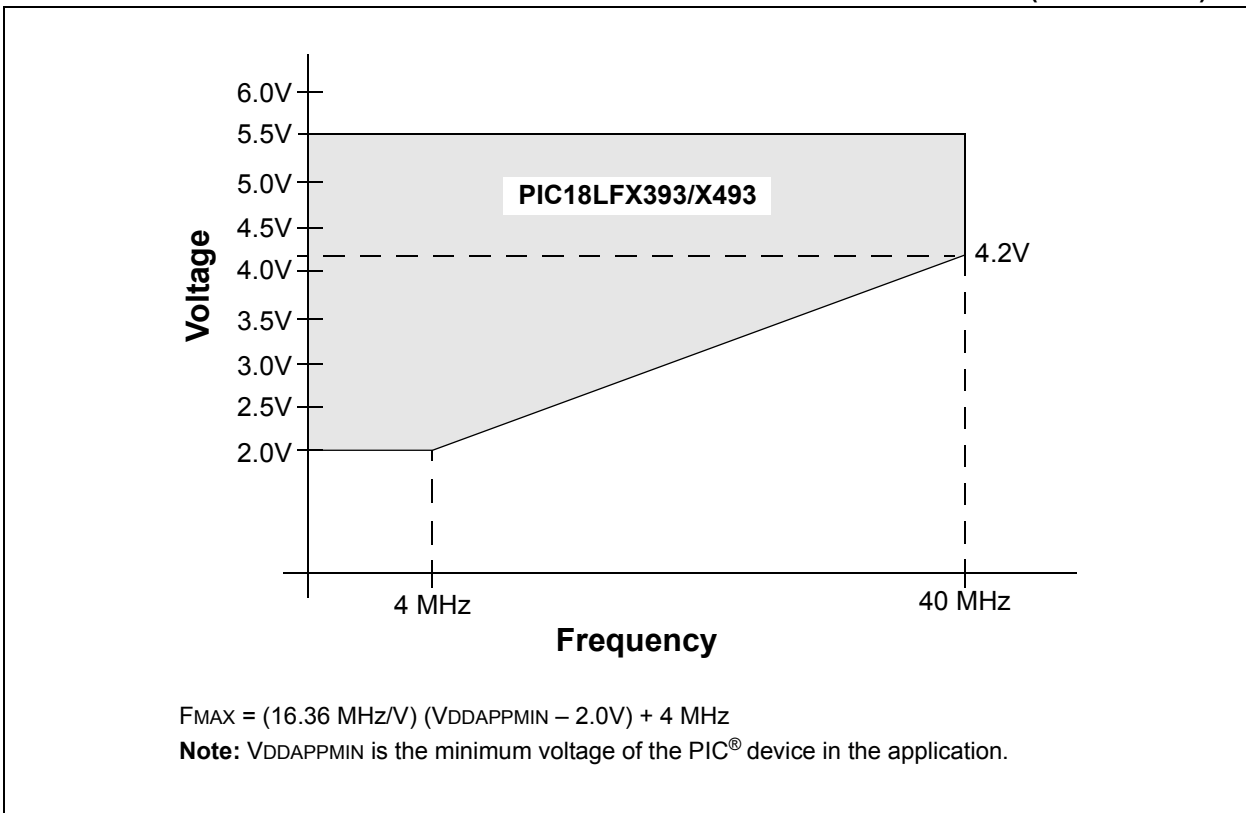

FIGURE 4-2: PIC18LF6393/6493/8393/8493 VOLTAGE-FREQUENCY GRAPH (INDUSTRIAL)



PIC18F6393/6493/8393/8493

TABLE 4-1: A/D CONVERTER CHARACTERISTICS: PIC18F6393/6493/8393/8493 (INDUSTRIAL)

Param No.	Sym	Characteristic	Min	Typ	Max	Units	Conditions	
A01	NR	Resolution	—	—	12	bit		$\Delta V_{REF} \geq 3.0V$
A03	EIL	Integral Linearity Error	—	$<\pm 1$	± 2.0	LSB	$V_{DD} = 3.0V$	$\Delta V_{REF} \geq 3.0V$
			—	—	± 2.0	LSB	$V_{DD} = 5.0V$	
A04	EDL	Differential Linearity Error	—	$<\pm 1$	+1.5/-1.0	LSB	$V_{DD} = 3.0V$	$\Delta V_{REF} \geq 3.0V$
			—	—	+1.5/-1.0	LSB	$V_{DD} = 5.0V$	
A06	EOFF	Offset Error	—	$<\pm 1$	± 5	LSB	$V_{DD} = 3.0V$	$\Delta V_{REF} \geq 3.0V$
			—	—	± 3	LSB	$V_{DD} = 5.0V$	
A07	EGN	Gain Error	—	$<\pm 1$	± 2.00	LSB	$V_{DD} = 3.0V$	$\Delta V_{REF} \geq 3.0V$
			—	—	± 2.00	LSB	$V_{DD} = 5.0V$	
A10	—	Monotonicity	Guaranteed ⁽¹⁾			—		$V_{SS} \leq V_{AIN} \leq V_{REF}$
A20	ΔV_{REF}	Reference Voltage Range ($V_{REFH} - V_{REFL}$)	3	—	$V_{DD} - V_{SS}$	V		For 12-bit resolution
A21	V_{REFH}	Reference Voltage High	$V_{SS} + \Delta V_{REF}$	—	V_{DD}	V		For 12-bit resolution
A22	V_{REFL}	Reference Voltage Low	V_{SS}	—	$V_{DD} - \Delta V_{REF}$	V		For 12-bit resolution
A25	V_{AIN}	Analog Input Voltage	V_{REFL}	—	V_{REFH}	V		
A30	Z_{AIN}	Recommended Impedance of Analog Voltage Source	—	—	2.5	k Ω		
A50	IREF	V_{REF} Input Current ⁽²⁾	—	—	5	μA		During V_{AIN} acquisition. During A/D conversion cycle.
			—	—	150	μA		

Note 1: The A/D conversion result never decreases with an increase in the input voltage and has no missing codes.

Note 2: V_{REFH} current is from the RA3/AN3/ V_{REF+} /SEG17 pin or V_{DD} , whichever is selected as the V_{REFH} source. V_{REFL} current is from the RA2/AN2/ V_{REF-} /SEG16 pin or V_{SS} , whichever is selected as the V_{REFL} source.

PIC18F6393/6493/8393/8493

FIGURE 4-3: A/D CONVERSION TIMING

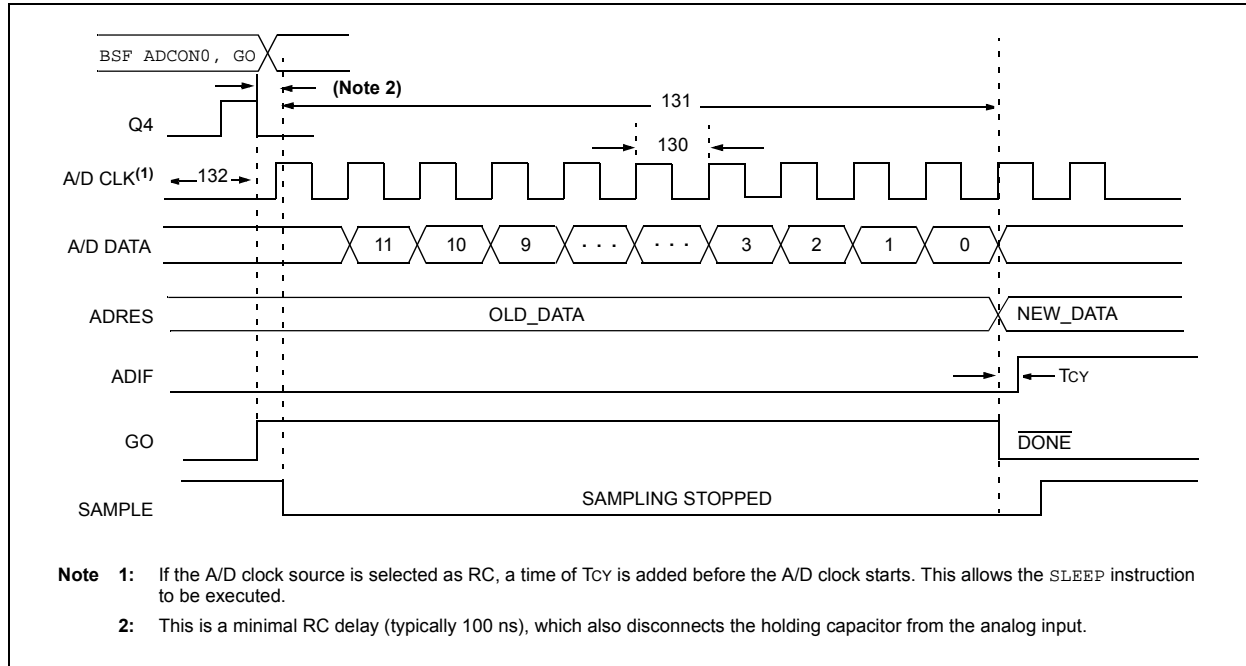

TABLE 4-2: A/D CONVERSION REQUIREMENTS

Param No.	Symbol	Characteristic	Min	Max	Units	Conditions	
130	TAD	A/D Clock Period	PIC18FXXXX	0.8	12.5 ⁽¹⁾	μs	TOSC based, VREF ≥ 3.0V
			PIC18LFXXXX	1.4	25.0 ⁽¹⁾	μs	VDD = 3.0V; TOSC based, VREF full range
		PIC18FXXXX	—	1	μs	A/D RC mode	
		PIC18LFXXXX	—	3	μs	VDD = 3.0V; A/D RC mode	
131	T _{CV}	Conversion Time (not including acquisition time) ⁽²⁾	13	14	TAD		
132	T _{ACQ}	Acquisition Time ⁽³⁾	1.4	—	μs		
135	T _{SWC}	Switching Time from Convert → Sample	—	(Note 4)			
137	T _{DIS}	Discharge Time	0.2	—	μs		

- Note 1:** The time of the A/D clock period is dependent on the device frequency and the TAD clock divider.
- Note 2:** ADRES registers may be read on the following T_{CY} cycle.
- Note 3:** The time for the holding capacitor to acquire the “New” input voltage when the voltage changes full scale after the conversion (VDD to VSS or VSS to VDD). The source impedance (R_S) on the input channels is 50Ω.
- Note 4:** On the following cycle of the device clock.

PIC18F6393/6493/8393/8493

5.0 PACKAGING INFORMATION

5.1 Package Marking Information

64-Lead TQFP (10x10x1mm)

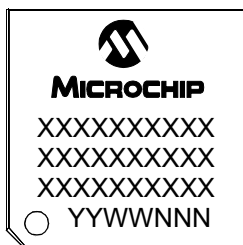

Example

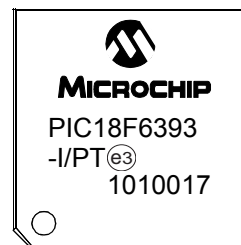

80-Lead TQFP (12x12x1mm)

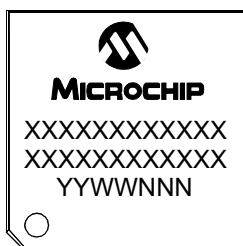

Example

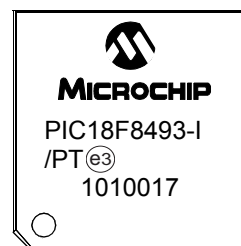

Legend:	XX...X	Customer-specific information
	Y	Year code (last digit of calendar year)
	YY	Year code (last 2 digits of calendar year)
	WW	Week code (week of January 1 is week '01')
	NNN	Alphanumeric traceability code
	*	Pb-free JEDEC designator for Matte Tin (Sn)
		This package is Pb-free. The Pb-free JEDEC designator (e3) can be found on the outer packaging for this package.
Note:	In the event the full Microchip part number cannot be marked on one line, it will be carried over to the next line, thus limiting the number of available characters for customer-specific information.	

PIC18F6393/6493/8393/8493

64-Lead Plastic Thin Quad Flatpack (PT) – 10x10x1 mm Body, 2.00 mm [TQFP]

Note: For the most current package drawings, please see the Microchip Packaging Specification located at <http://www.microchip.com/packaging>

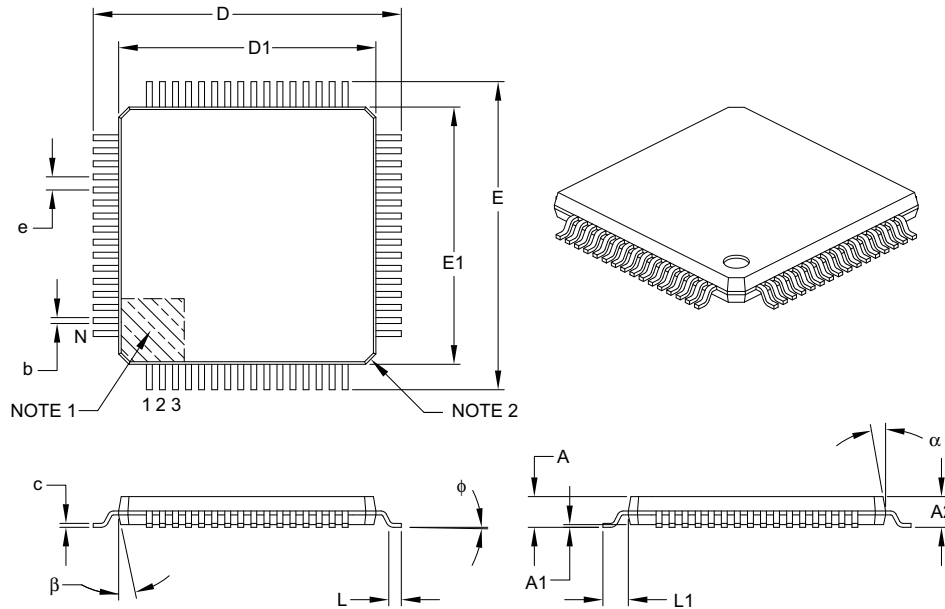

Dimension Limits	Units	MILLIMETERS		
		MIN	NOM	MAX
Number of Leads	N	64		
Lead Pitch	e	0.50 BSC		
Overall Height	A	–	–	1.20
Molded Package Thickness	A2	0.95	1.00	1.05
Standoff	A1	0.05	–	0.15
Foot Length	L	0.45	0.60	0.75
Footprint	L1	1.00 REF		
Foot Angle	ϕ	0°	3.5°	7°
Overall Width	E	12.00 BSC		
Overall Length	D	12.00 BSC		
Molded Package Width	E1	10.00 BSC		
Molded Package Length	D1	10.00 BSC		
Lead Thickness	c	0.09	–	0.20
Lead Width	b	0.17	0.22	0.27
Mold Draft Angle Top	α	11°	12°	13°
Mold Draft Angle Bottom	β	11°	12°	13°

Notes:

- Pin 1 visual index feature may vary, but must be located within the hatched area.
- Chamfers at corners are optional; size may vary.
- Dimensions D1 and E1 do not include mold flash or protrusions. Mold flash or protrusions shall not exceed 0.25 mm per side.
- Dimensioning and tolerancing per ASME Y14.5M.

BSC: Basic Dimension. Theoretically exact value shown without tolerances.

REF: Reference Dimension, usually without tolerance, for information purposes only.

Microchip Technology Drawing C04-085B

PIC18F6393/6493/8393/8493

64-Lead Plastic Thin Quad Flatpack (PT) – 10x10x1 mm Body, 2.00 mm [TQFP]

Note: For the most current package drawings, please see the Microchip Packaging Specification located at <http://www.microchip.com/packaging>

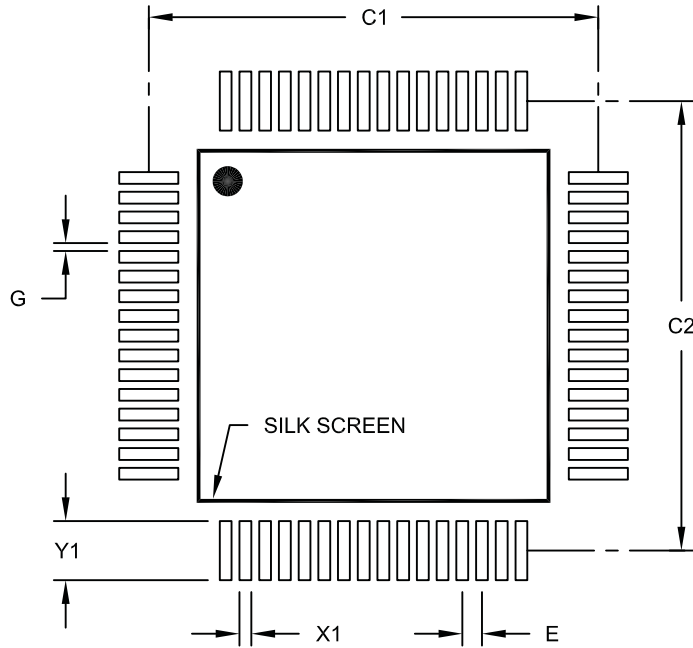

RECOMMENDED LAND PATTERN

Dimension Limits	Units	MILLIMETERS		
		MIN	NOM	MAX
Contact Pitch	E	0.50 BSC		
Contact Pad Spacing	C1		11.40	
Contact Pad Spacing	C2		11.40	
Contact Pad Width (X64)	X1			0.30
Contact Pad Length (X64)	Y1			1.50
Distance Between Pads	G	0.20		

Notes:

1. Dimensioning and tolerancing per ASME Y14.5M

BSC: Basic Dimension. Theoretically exact value shown without tolerances.

Microchip Technology Drawing No. C04-2085A

PIC18F6393/6493/8393/8493

80-Lead Plastic Thin Quad Flatpack (PT) – 12x12x1 mm Body, 2.00 mm [TQFP]

Note: For the most current package drawings, please see the Microchip Packaging Specification located at <http://www.microchip.com/packaging>

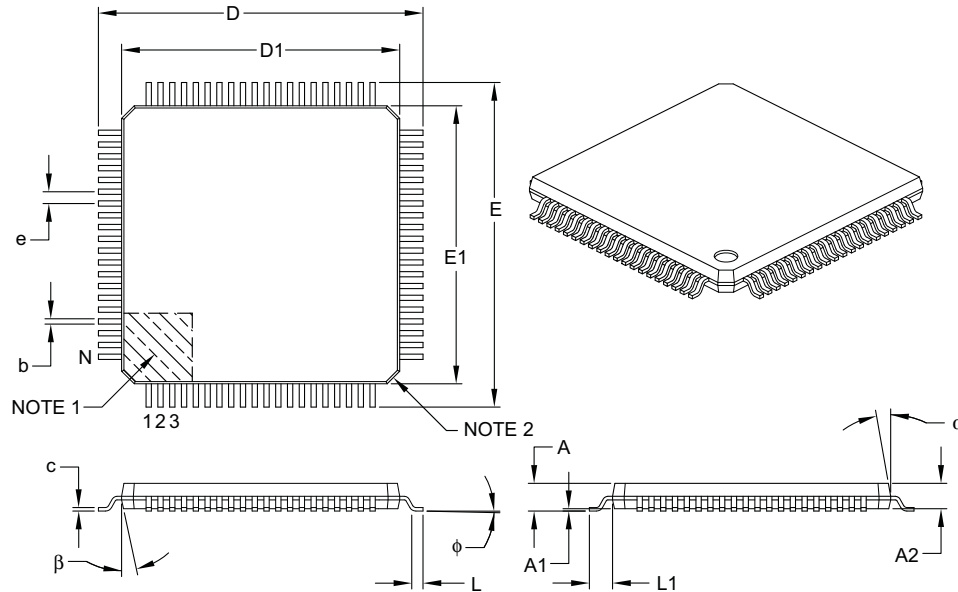

Dimension Limits	Units	MILLIMETERS		
		MIN	NOM	MAX
Number of Leads	N	80		
Lead Pitch	e	0.50 BSC		
Overall Height	A	–	–	1.20
Molded Package Thickness	A2	0.95	1.00	1.05
Standoff	A1	0.05	–	0.15
Foot Length	L	0.45	0.60	0.75
Footprint	L1	1.00 REF		
Foot Angle	ϕ	0°	3.5°	7°
Overall Width	E	14.00 BSC		
Overall Length	D	14.00 BSC		
Molded Package Width	E1	12.00 BSC		
Molded Package Length	D1	12.00 BSC		
Lead Thickness	c	0.09	–	0.20
Lead Width	b	0.17	0.22	0.27
Mold Draft Angle Top	α	11°	12°	13°
Mold Draft Angle Bottom	β	11°	12°	13°

Notes:

- Pin 1 visual index feature may vary, but must be located within the hatched area.
- Chamfers at corners are optional; size may vary.
- Dimensions D1 and E1 do not include mold flash or protrusions. Mold flash or protrusions shall not exceed 0.25 mm per side.
- Dimensioning and tolerancing per ASME Y14.5M.

BSC: Basic Dimension. Theoretically exact value shown without tolerances.

REF: Reference Dimension, usually without tolerance, for information purposes only.

Microchip Technology Drawing C04-092B

PIC18F6393/6493/8393/8493

80-Lead Plastic Thin Quad Flatpack (PT) – 12x12x1 mm Body, 2.00 mm [TQFP]

Note: For the most current package drawings, please see the Microchip Packaging Specification located at <http://www.microchip.com/packaging>

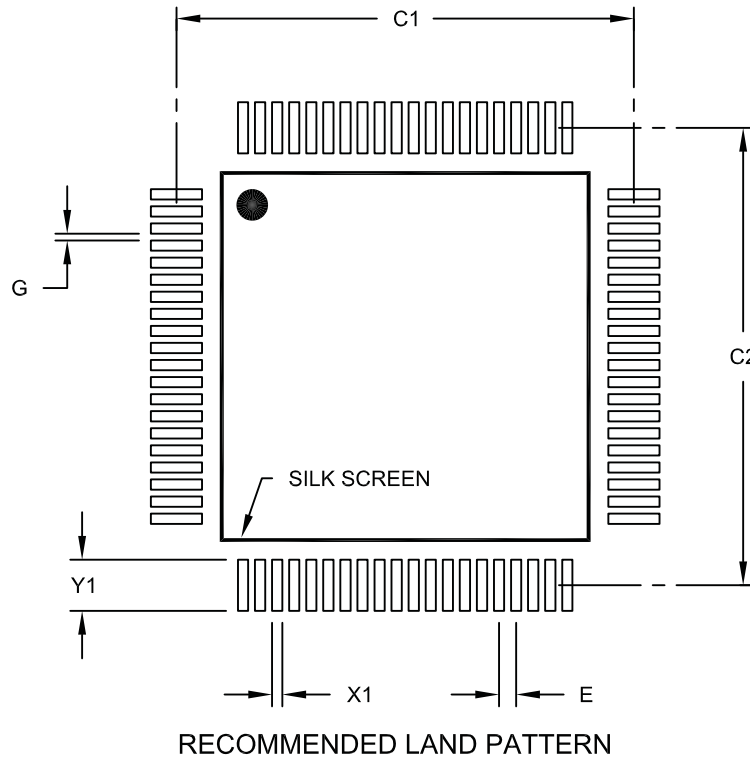

		Units	MILLIMETERS		
		Dimension Limits	MIN	NOM	MAX
Contact Pitch	E		0.50 BSC		
Contact Pad Spacing	C1			13.40	
Contact Pad Spacing	C2			13.40	
Contact Pad Width (X80)	X1				0.30
Contact Pad Length (X80)	Y1				1.50
Distance Between Pads	G	0.20			

Notes:

1. Dimensioning and tolerancing per ASME Y14.5M

BSC: Basic Dimension. Theoretically exact value shown without tolerances.

Microchip Technology Drawing No. C04-2092A

PIC18F6393/6493/8393/8493

NOTES:

PIC18F6393/6493/8393/8493

APPENDIX A: REVISION HISTORY

Revision A (September 2007)

Original data sheet for the PIC18F6393/6493/8393/8493 devices.

Revision B (October 2009)

Removed "Preliminary" marking.

Revision C (August 2010)

Changes and additions were made to the "Power-Managed Modes", "Flexible Oscillator Structure", "Peripheral Highlights" and "Special Microcontroller Features" sections. Changes were made to Figure 1-1, Figure 1-2, Table 1-2 and Table 1-3, including edits to the

legends of those tables. New text has replaced all in 2.4 "Operation in Power-Managed Modes". Corrections have been made to 4.0 "Electrical Characteristics". The extended temperature has been removed from the "Product Identification System" information. New packaging diagrams were added because the diagrams referenced in the document, "PIC18F6390/6490/8390/8490 Data Sheet" (DS39629), have not been updated. Minor typographical edits throughout the document.

APPENDIX B: DEVICE DIFFERENCES

The differences between the devices listed in this data sheet are shown in Table B-1.

TABLE B-1: DEVICE DIFFERENCES

Features	PIC18F6393	PIC18F6493	PIC18F8393	PIC18F8493
Number of Pixels the LCD Driver Can Drive	128 (4 x 32)	128 (4 x 32)	192 (4 x 48)	192 (4 x 48)
I/O Ports	Ports A, B, C, D, E, F, G	Ports A, B, C, D, E, F, G	Ports A, B, C, D, E, F, G, H, J	Ports A, B, C, D, E, F, G, H, J
Flash Program Memory	8 Kbytes	16 Kbytes	8 Kbytes	16 Kbytes
Packages	64-Pin TQFP	64-Pin TQFP	80-Pin TQFP	80-Pin TQFP

PIC18F6393/6493/8393/8493

APPENDIX C: CONVERSION CONSIDERATIONS

This appendix discusses the considerations for converting from previous versions of a device to the ones listed in this data sheet. Typically, these changes are due to the differences in the process technology used. An example of this type of conversion is from a PIC16C74A to a PIC16C74B.

Not Applicable

APPENDIX D: MIGRATION FROM BASELINE TO ENHANCED DEVICES

This section discusses how to migrate from a Baseline device (i.e., PIC16C5X) to an Enhanced MCU device (i.e., PIC18FXXX).

The following are the list of modifications over the PIC16C5X microcontroller family:

Not Currently Available

APPENDIX E: MIGRATION FROM MID-RANGE TO ENHANCED DEVICES

A detailed discussion of the differences between the mid-range MCU devices (i.e., PIC16CXXX) and the enhanced devices (i.e., PIC18FXXX) is provided in AN716, “*Migrating Designs from PIC16C74A/74B to PIC18C442*”. The changes discussed, while device-specific, are generally applicable to all mid-range to enhanced device migrations.

This Application Note is available as Literature Number DS00716.

APPENDIX F: MIGRATION FROM HIGH-END TO ENHANCED DEVICES

A detailed discussion of the migration pathway, and differences between the high-end MCU devices (i.e., PIC17CXXX), and the enhanced devices (i.e., PIC18FXXX) is provided in AN726, “*PIC17CXXX to PIC18CXXX Migration*”. This Application Note is available as Literature Number DS00726.

PIC18F6393/6493/8393/8493

NOTES:

INDEX

A

A/D	31
A/D Converter Interrupt, Configuring	35
Acquisition Requirements	36
ADCON0 Register	31
ADCON1 Register	31
ADCON2 Register	31
ADRESH Register	31, 34
ADRESL Register	31
Analog Port Pins, Configuring	38
Associated Registers	40
Configuring the Module	35
Conversion Clock (TAD)	37
Conversion Requirements	46
Conversion Status (GO/DONE Bit)	34
Conversions	39
Converter Characteristics	45
Discharge	39
Operation in Power-Managed Modes	38
Selecting and Configuring Acquisition Time	37
Special Event Trigger (ECCP2)	40
Transfer Function	35
Use of the ECCP2 Trigger	40
Absolute Maximum Ratings	43
ADCON0 Register	31
GO/DONE Bit	34
ADCON1 Register	31
ADCON2 Register	31
ADRESH Register	31
ADRESL Register	31, 34
Analog-to-Digital Converter. <i>See</i> A/D.	

B

Block Diagrams	
A/D	34
Analog Input Model	35
PIC18F6X93 (64-Pin)	11
PIC18F8X93 (80-Pin)	12

C

Compare (ECCP2 Module)	
Special Event Trigger	40
Conversion Considerations	54
Customer Change Notification Service	59
Customer Notification Service	59
Customer Support	59

D

Device Differences	53
Device ID Registers	41
Device Overview	9
Details of Individual Devices	9
Features (table)	10
Special Features	9
Documentation	
Most Current Versions	7
Related Data Sheet	9

E

Electrical Characteristics	43
A/D Converter	45
Absolute Maximum Ratings	43
Low-Power Voltage-Frequency Graph	44
Voltage-Frequency Graph	44
Equations	
A/D Acquisition Time	36
A/D Minimum Charging Time	36
Calculating the Minimum Required Acquisition Time	36
Errata	7

I

Internet Address	59
Interrupt Sources	
A/D Conversion Complete	35

L

LCD Driver	
Features	3

M

Microchip Internet Web Site	59
Microcontroller	
Special Features	3
Migration from Baseline to Enhanced Devices	54
Migration from High-End to Enhanced Devices	55
Migration from Mid-Range to Enhanced Devices	55

O

Oscillator Structure	
Features	3

P

Packaging	
Information	47
Marking	47
Peripheral Highlights	3
Pin Diagrams	
64-Pin TQFP	4
80-Pin TQFP	5
Pin Functions	
AVDD	30
AVDD	20
AVss	20
AVss	30
COM0	18, 26
LCDBIAS1	18, 26
LCDBIAS2	18, 26
LCDBIAS3	18, 26
MCLR/VPP/RG5	13, 21
OSC1/CLKI/RA7	13, 21
OSC2/CLKO/RA6	13, 21
RA0/AN0	14, 22
RA1/AN1	14, 22
RA2/AN2/VREF-/SEG16	14, 22

PIC18F6393/6493/8393/8493

RA3/AN3/VREF+/SEG17	14, 22	RH2/SEG45	29
RA4/T0CKI/SEG14	14, 22	RH3/SEG44	29
RA5/AN4/HLVDIN/SEG15	14, 22	RH4/SEG40	29
RB0/INT0	15, 23	RH5/SEG41	29
RB1/INT1/SEG8	15, 23	RH6/SEG42	29
RB2/INT2/SEG9	15, 23	RH7/SEG43	29
RB3/INT3/SEG10	15, 23	RJ0/SEG32	30
RB4/KBI0/SEG11	15, 23	RJ1/SEG33	30
RB5/KBI1	15, 23	RJ2/SEG34	30
RB6/KBI2/PGC	15, 23	RJ3/SEG35	30
RB7/KBI3/PGD	15, 23	RJ4/SEG39	30
RC0/T1OSO/T13CKI	16, 24	RJ5/SEG38	30
RC1/T1OSI/CCP2	16, 24	RJ6/SEG37	30
RC2/CCP1/SEG13	16, 24	RJ7/SEG36	30
RC3/SCK/SCL	16, 24	VDD	30
RC4/SDI/SDA	16, 24	VDD	20
RC5/SDO/SEG12	16, 24	Vss	30
RC6/TX1/CK1	16, 24	Vss	20
RC7/RX1/DT1	16, 24	Pinout I/O Descriptions	
RD0/SEG0	17, 25	PIC18F6X93	13
RD0/SEG1	17	PIC18F8X93	21
RD1/SEG1	25	Power-Managed Modes	
RD2/SEG2	17, 25	and A/D Operation	38
RD3/SEG3	17, 25	Features	3
RD4/SEG4	17, 25	Product Identification System	61
RD5/SEG5	17, 25	R	
RD6/SEG6	17, 25	Reader Response	60
RD7/SEG7	17, 25	Registers	
RE4/COM1	18, 26	ADCON0 (A/D Control 0)	31
RE5/COM2	18, 26	ADCON1 (A/D Control 1)	32
RE6/COM3	18, 26	ADCON2 (A/D Control 2)	33
RE7/CCP2/SEG31	18, 26	DEVID1 (Device ID 1)	42
RF0/AN5/SEG18	19, 27	DEVID2 (Device ID 2)	42
RF1/AN6/C2OUT/SEG19	19, 27	Revision History	53
RF2/AN7/C1OUT/SEG20	19, 27	S	
RF3/AN8/SEG21	19, 27	Special Features of the CPU	41
RF4/AN9/SEG22	19, 27	Device ID Registers	41
RF5/AN10/CVREF/SEG23	19, 27	T	
RF6/AN11/SEG24	19, 27	Timing Diagrams	
RF7/SS/SEG25	19, 27	A/D Conversion	46
RG0/SEG30	20, 28	W	
RG1/TX2/CK2/SEG29	20, 28	WWW Address	59
RG2/RX2/DT2/SEG28	20, 28	WWW, On-Line Support	7
RG3/SEG27	20, 28		
RG4/SEG26	20, 28		
RG5	20, 28		
RH0/SEG47	29		
RH1/SEG46	29		

THE MICROCHIP WEB SITE

Microchip provides online support via our WWW site at www.microchip.com. This web site is used as a means to make files and information easily available to customers. Accessible by using your favorite Internet browser, the web site contains the following information:

- **Product Support** – Data sheets and errata, application notes and sample programs, design resources, user's guides and hardware support documents, latest software releases and archived software
- **General Technical Support** – Frequently Asked Questions (FAQ), technical support requests, online discussion groups, Microchip consultant program member listing
- **Business of Microchip** – Product selector and ordering guides, latest Microchip press releases, listing of seminars and events, listings of Microchip sales offices, distributors and factory representatives

CUSTOMER CHANGE NOTIFICATION SERVICE

Microchip's customer notification service helps keep customers current on Microchip products. Subscribers will receive e-mail notification whenever there are changes, updates, revisions or errata related to a specified product family or development tool of interest.

To register, access the Microchip web site at www.microchip.com, click on Customer Change Notification and follow the registration instructions.

CUSTOMER SUPPORT

Users of Microchip products can receive assistance through several channels:

- Distributor or Representative
- Local Sales Office
- Field Application Engineer (FAE)
- Technical Support
- Development Systems Information Line

Customers should contact their distributor, representative or field application engineer (FAE) for support. Local sales offices are also available to help customers. A listing of sales offices and locations is included in the back of this document.

Technical support is available through the web site at: <http://support.microchip.com>

PIC18F6393/6493/8393/8493

READER RESPONSE

It is our intention to provide you with the best documentation possible to ensure successful use of your Microchip product. If you wish to provide your comments on organization, clarity, subject matter, and ways in which our documentation can better serve you, please FAX your comments to the Technical Publications Manager at (480) 792-4150.

Please list the following information, and use this outline to provide us with your comments about this document.

To: Technical Publications Manager
RE: Reader Response
Total Pages Sent _____

From: Name _____
Company _____
Address _____
City / State / ZIP / Country _____
Telephone: (_____) _____ - _____ FAX: (_____) _____ - _____

Application (optional):

Would you like a reply? ___Y ___N

Device: PIC18F6393/6493/8393/8493 Literature Number: DS39896C

Questions:

1. What are the best features of this document?

2. How does this document meet your hardware and software development needs?

3. Do you find the organization of this document easy to follow? If not, why?

4. What additions to the document do you think would enhance the structure and subject?

5. What deletions from the document could be made without affecting the overall usefulness?

6. Is there any incorrect or misleading information (what and where)?

7. How would you improve this document?

PIC18F6393/6493/8393/8493

PRODUCT IDENTIFICATION SYSTEM

To order or obtain information, e.g., on pricing or delivery, refer to the factory or the listed sales office.

<u>PART NO.</u>	<u>X</u>	<u>/XX</u>	<u>XXX</u>
Device	Temperature Range	Package	Pattern
Device ^{(1), (2)}	PIC18F6393, PIC18F6493, PIC18F8393, PIC18F8493 – VDD range: 4.2V to 5.5V PIC18LF6393, PIC18LF6493, PIC18LF8393, PIC18LF8493 – VDD range: 2.0V to 5.5V		
Temperature Range	I	= -40°C to +85°C (Industrial)	
Package	PT	= TQFP (Thin Quad Flatpack)	
Pattern	QTP, SQTP, Code or Special Requirements (blank otherwise)		

Examples:

a) PIC18LF6393-I/PT 301 = Industrial temp., TQFP package, Extended VDD limits, QTP pattern #301.

b) PIC18LF6393-I/PT = Industrial temp., TQFP package, Extended VDD limits.

Note 1: F = Standard Voltage Range
 LF = Wide Voltage Range

2: T = in Tape and Reel TQFP packages only.



WORLDWIDE SALES AND SERVICE

AMERICAS

Corporate Office
2355 West Chandler Blvd.
Chandler, AZ 85224-6199
Tel: 480-792-7200
Fax: 480-792-7277
Technical Support:
<http://support.microchip.com>
Web Address:
www.microchip.com

Atlanta
Duluth, GA
Tel: 678-957-9614
Fax: 678-957-1455

Boston
Westborough, MA
Tel: 774-760-0087
Fax: 774-760-0088

Chicago
Itasca, IL
Tel: 630-285-0071
Fax: 630-285-0075

Cleveland
Independence, OH
Tel: 216-447-0464
Fax: 216-447-0643

Dallas
Addison, TX
Tel: 972-818-7423
Fax: 972-818-2924

Detroit
Farmington Hills, MI
Tel: 248-538-2250
Fax: 248-538-2260

Kokomo
Kokomo, IN
Tel: 765-864-8360
Fax: 765-864-8387

Los Angeles
Mission Viejo, CA
Tel: 949-462-9523
Fax: 949-462-9608

Santa Clara
Santa Clara, CA
Tel: 408-961-6444
Fax: 408-961-6445

Toronto
Mississauga, Ontario,
Canada
Tel: 905-673-0699
Fax: 905-673-6509

ASIA/PACIFIC

Asia Pacific Office
Suites 3707-14, 37th Floor
Tower 6, The Gateway
Harbour City, Kowloon
Hong Kong
Tel: 852-2401-1200
Fax: 852-2401-3431

Australia - Sydney
Tel: 61-2-9868-6733
Fax: 61-2-9868-6755

China - Beijing
Tel: 86-10-8528-2100
Fax: 86-10-8528-2104

China - Chengdu
Tel: 86-28-8665-5511
Fax: 86-28-8665-7889

China - Chongqing
Tel: 86-23-8980-9588
Fax: 86-23-8980-9500

China - Hong Kong SAR
Tel: 852-2401-1200
Fax: 852-2401-3431

China - Nanjing
Tel: 86-25-8473-2460
Fax: 86-25-8473-2470

China - Qingdao
Tel: 86-532-8502-7355
Fax: 86-532-8502-7205

China - Shanghai
Tel: 86-21-5407-5533
Fax: 86-21-5407-5066

China - Shenyang
Tel: 86-24-2334-2829
Fax: 86-24-2334-2393

China - Shenzhen
Tel: 86-755-8203-2660
Fax: 86-755-8203-1760

China - Wuhan
Tel: 86-27-5980-5300
Fax: 86-27-5980-5118

China - Xian
Tel: 86-29-8833-7252
Fax: 86-29-8833-7256

China - Xiamen
Tel: 86-592-2388138
Fax: 86-592-2388130

China - Zhuhai
Tel: 86-756-3210040
Fax: 86-756-3210049

ASIA/PACIFIC

India - Bangalore
Tel: 91-80-3090-4444
Fax: 91-80-3090-4123

India - New Delhi
Tel: 91-11-4160-8631
Fax: 91-11-4160-8632

India - Pune
Tel: 91-20-2566-1512
Fax: 91-20-2566-1513

Japan - Yokohama
Tel: 81-45-471- 6166
Fax: 81-45-471-6122

Korea - Daegu
Tel: 82-53-744-4301
Fax: 82-53-744-4302

Korea - Seoul
Tel: 82-2-554-7200
Fax: 82-2-558-5932 or
82-2-558-5934

Malaysia - Kuala Lumpur
Tel: 60-3-6201-9857
Fax: 60-3-6201-9859

Malaysia - Penang
Tel: 60-4-227-8870
Fax: 60-4-227-4068

Philippines - Manila
Tel: 63-2-634-9065
Fax: 63-2-634-9069

Singapore
Tel: 65-6334-8870
Fax: 65-6334-8850

Taiwan - Hsin Chu
Tel: 886-3-6578-300
Fax: 886-3-6578-370

Taiwan - Kaohsiung
Tel: 886-7-213-7830
Fax: 886-7-330-9305

Taiwan - Taipei
Tel: 886-2-2500-6610
Fax: 886-2-2508-0102

Thailand - Bangkok
Tel: 66-2-694-1351
Fax: 66-2-694-1350

EUROPE

Austria - Wels
Tel: 43-7242-2244-39
Fax: 43-7242-2244-393

Denmark - Copenhagen
Tel: 45-4450-2828
Fax: 45-4485-2829

France - Paris
Tel: 33-1-69-53-63-20
Fax: 33-1-69-30-90-79

Germany - Munich
Tel: 49-89-627-144-0
Fax: 49-89-627-144-44

Italy - Milan
Tel: 39-0331-742611
Fax: 39-0331-466781

Netherlands - Drunen
Tel: 31-416-690399
Fax: 31-416-690340

Spain - Madrid
Tel: 34-91-708-08-90
Fax: 34-91-708-08-91

UK - Wokingham
Tel: 44-118-921-5869
Fax: 44-118-921-5820