



PARA LIGHT ELECTRONICS CO., LTD.

4F, No.1, Lane 93, Chien Yi Road, Chung Ho City, Taipei, Taiwan
Tel: 886-2-2225-3733 Fax: 886-2-2225-4800
E-mail: para@para.com.tw <http://www.para.com.tw>

DATA SHEET

PART NO. : EP501IR1L015W

REV : A/1

CUSTOMER'S APPROVAL : _____

DCC : _____

DRAWING NO. : DS-50-10-XXX

DATE : 2011-07-29

Page : 1

●Package Dimension

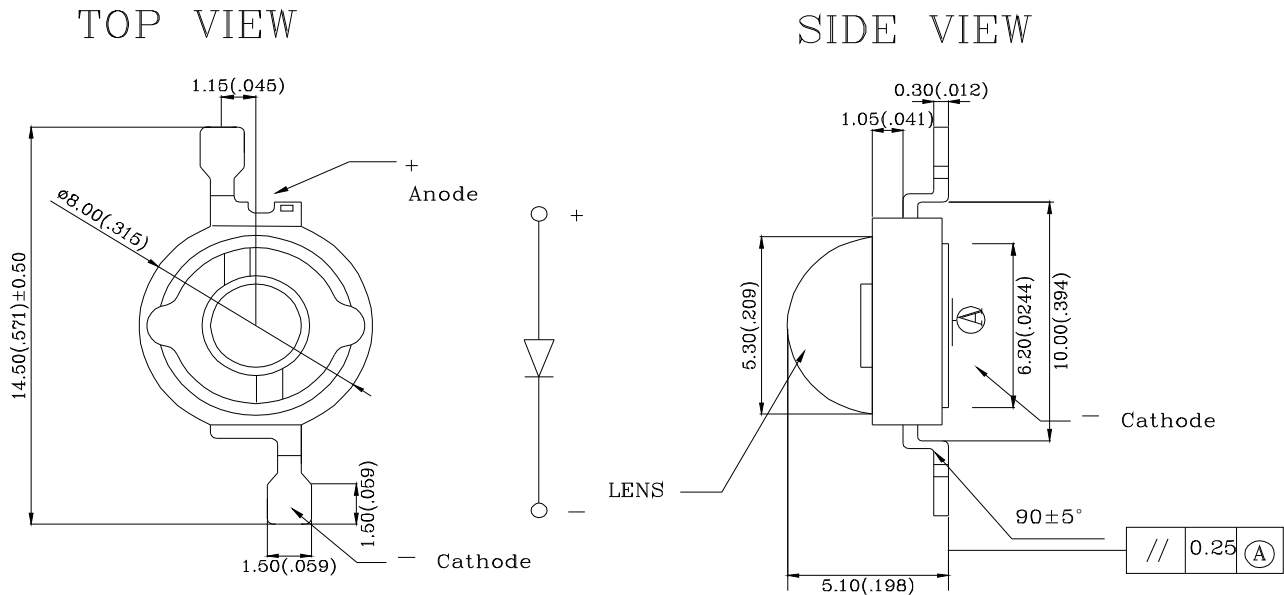

Note:

1. All dimensions are in millimeters.
2. Tolerance is ± 0.25 mm (.010") unless otherwise noted.

●Feature

1. Long operating life.
2. Low voltage DC operated.
3. Instant light (Less than 100NS).
4. RoHS Compliant.
5. Cool beam safe to touch.
6. Compatible to assemble, lead free reflow soldering process.
7. Night surveillance CCD camera illumination.



Enhance Power LED

EP501IR1L015W

REV:A/1

●Chip Material

1. Dice Material : GaAIAs
2. Light Color : Infrared
3. Lens Color : Water Clear

●Absolute Maximum Rating(Ta=25°C)

Symbol	Parameter	Rating	Unit
IF	DC Forward Current	350	mA
I _{pulse}	Peak Pulse Current; ($t_p \leq 100\mu s$, duty cycle=0.25)	500	mA
VR	Reverse Voltage	5	V
I _r	Reverse Current(VR=5V)	50	μA
T _j	LED Junction Temperature(at IF=700mA)	115	°C
*Topr	Operating Temperature	-30 ~ +100	°C
*Tstg	Storage Temperature	-40 ~ +100	°C
Tsol	Manual Soldering Time at 260°C(Max.)	5	seconds

Note :

* : Temperature for using with aluminum board.

●Electro-Optical Characteristic(Ta=25°C)

Parameter	Symbol	Min.	Typ.	Max.	Unit	Test Condition
Radiant Intensity	IE		25		mw/sr	IF=350mA
Viewing Angle	2 θ 1/2		120		deg	
Peak Emission Wavelength	λ_p		940		nm	IF=350mA
Spectral Line Half-Width	$\Delta\lambda$		50		nm	
Forward Voltage	VF		1.95	2.15	V	IF =350mA
Reverse Current	IR			50	μA	VR = 5V

● Typical Optical and Electrical

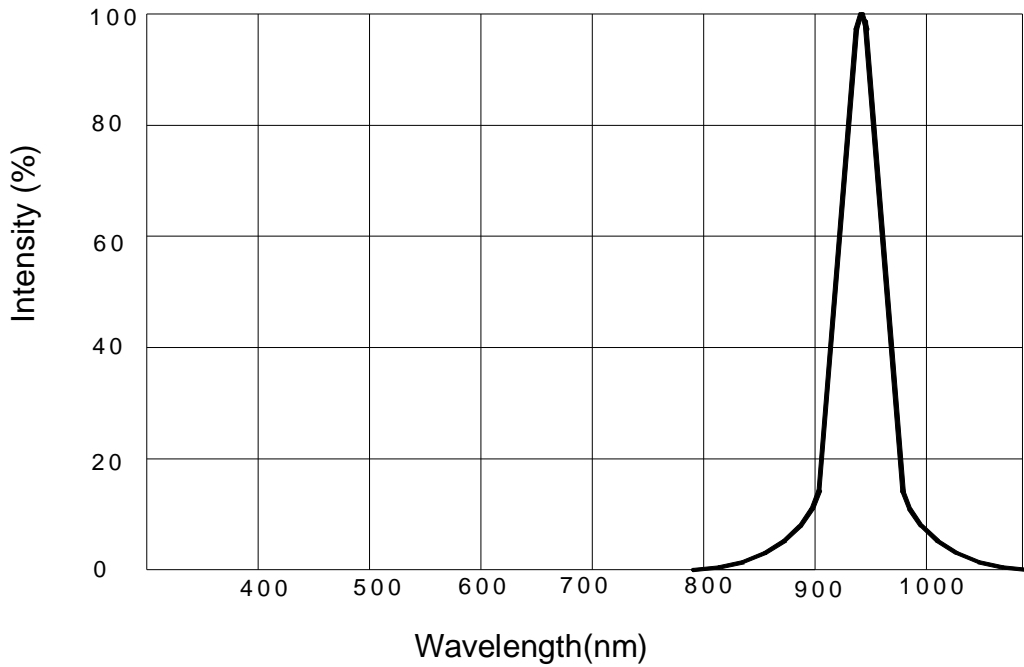

Relative Intensity VS Wavelength

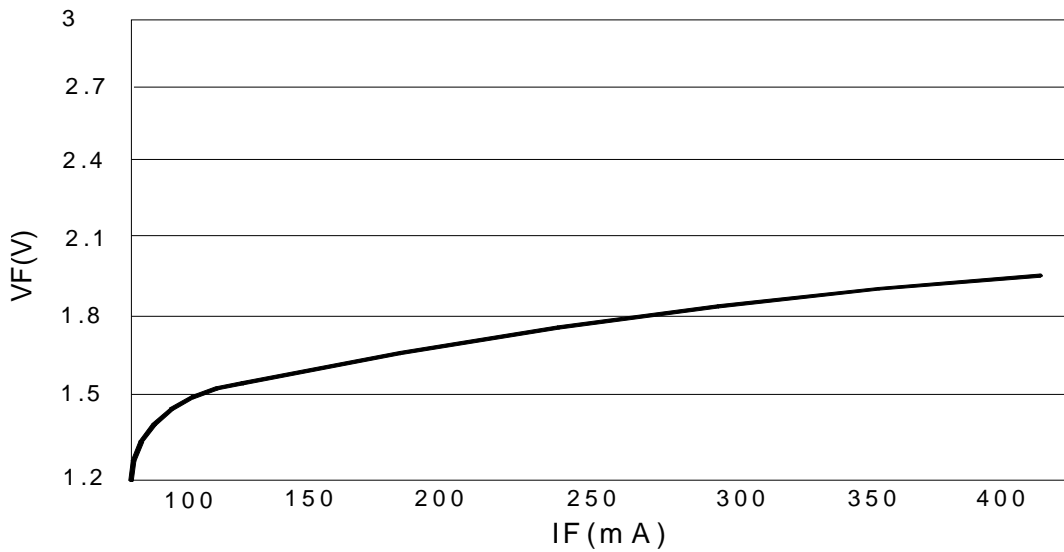

Operating Current VS Forward Voltage



Enhance Power LED

EP501IR1L015W

REV:A/1

•Typical Optical and Electrical

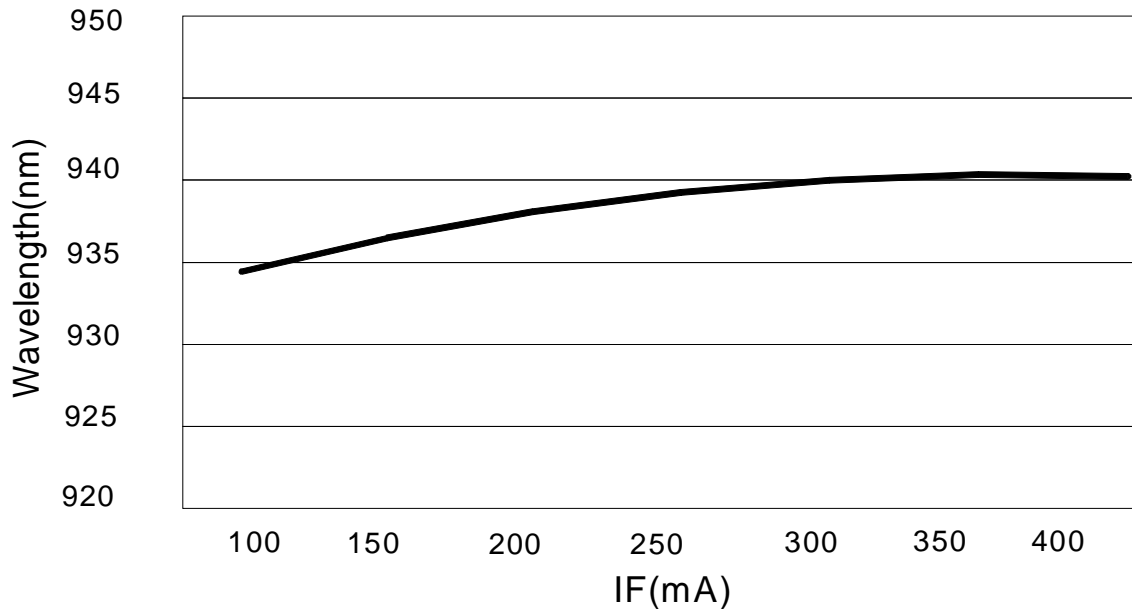

Forward Current VS Wavelength

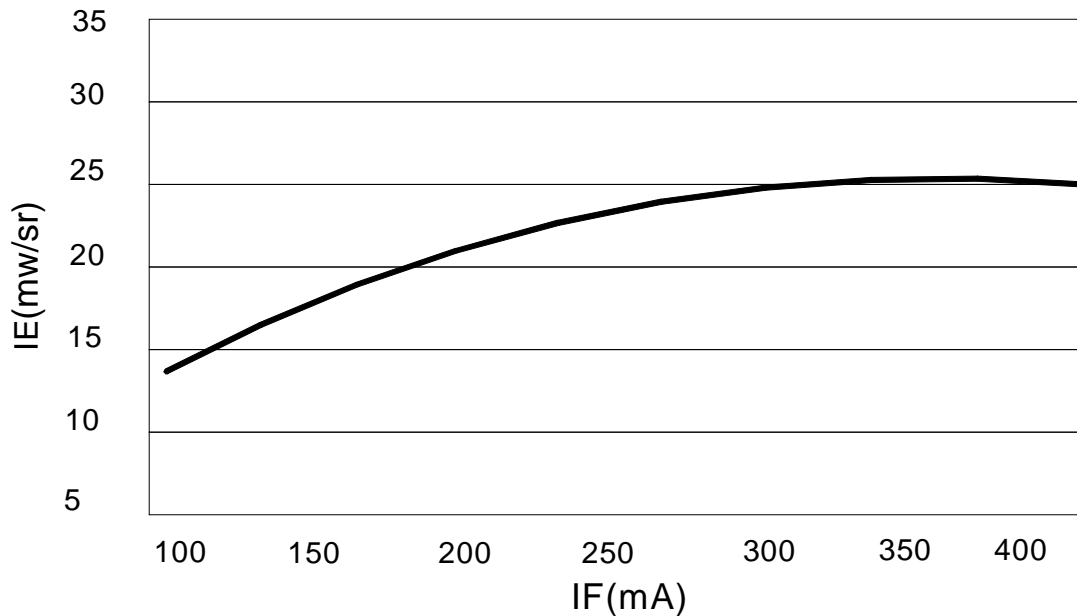

Forward Current VS IE

●Typical Optical and Electrical

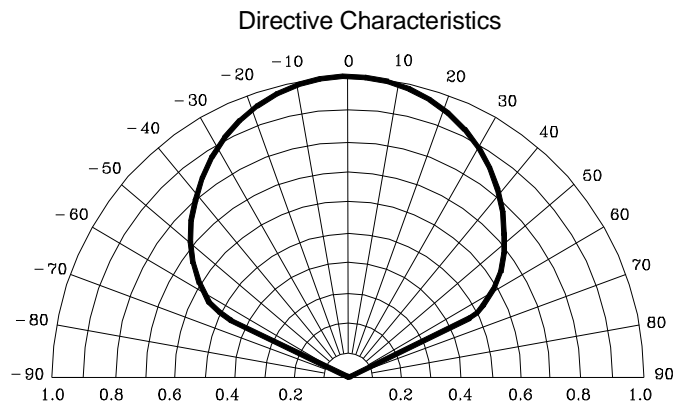

●Bin Code List

Radiant Intensity(IE)(Unit: mw/sr ,IF=350mA)		
Bin Code	Min	Max
E	20	23
F	23	27
G	27	33

Including test tolerance $\pm 10\%$

Forward Voltage(VF)(Unit: V ,IF=350mA)		
Bin Code	Min	Max
V1	1.55	1.75
V2	1.75	1.85
V3	1.85	1.95
V4	1.95	2.15

Including test tolerance $\pm 0.1V$



Enhance Power LED

EP501IR1L015W

REV:A/1

●Label Explanation

P/N: _____ EP501IR1L015W _____
QTY: _____ XXXX _____ PCS
LOT NO.: _____ LEM1001001 _____
BIN NO.: _____ Y/V3 _____

PART NO: EP501IR1L015W

LOT NO: L E M 10 1 001
 A B C D E F

A---L: Local F: Foreign

B---E: E-power

C---M: For series number

D---Year

E---Month

F---Spec.

BIN NO: Bin Code

●Caution

Handling note: Do not touch LED's lens.

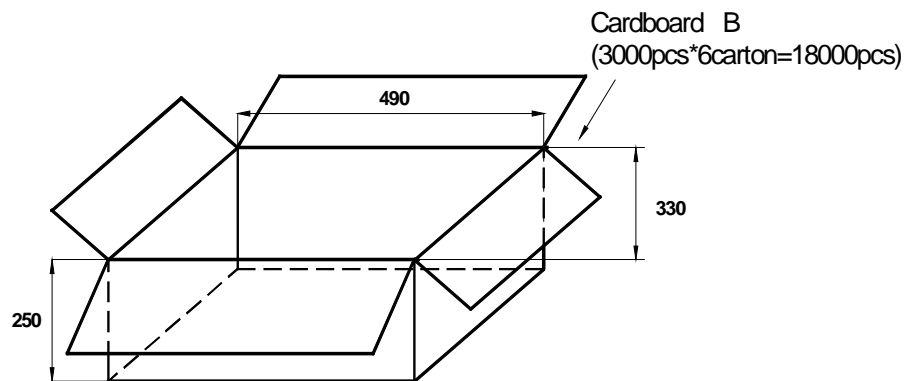
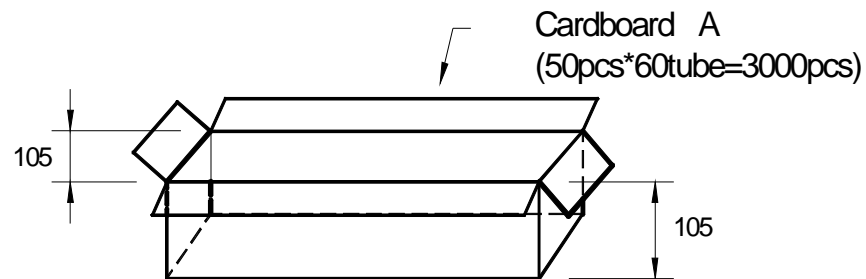
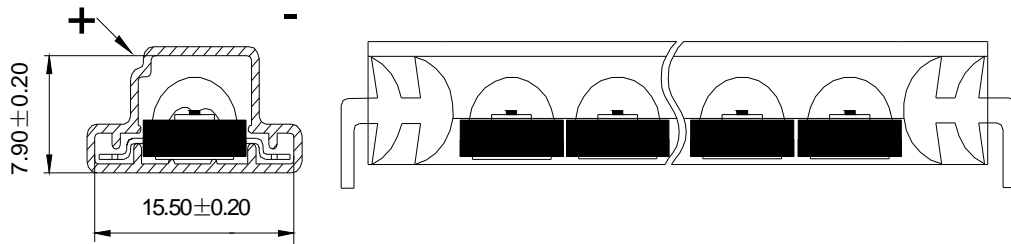

●Packing Specification**Note:**

1. All dimensions are in millimeters.
2. Normal packing Quantity:3000pcs.
3. The carton B contains 6 cartons A at maximum.

●Suggest Soldering Pad Dimension

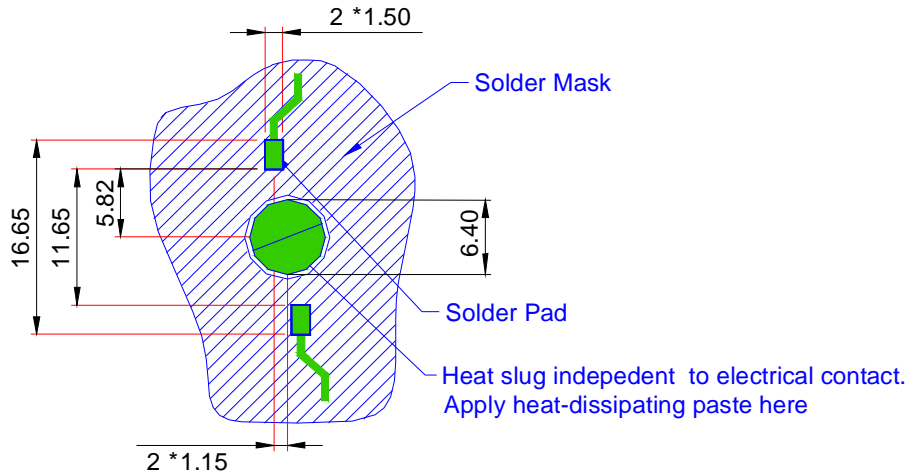

Note:

1. All dimensions are in millimeters .
2. The drawings are not to scale.
3. Solder pad can't be connected to slug.

●IR Reflow soldering profile for lead free soldering(J-STD-020C)

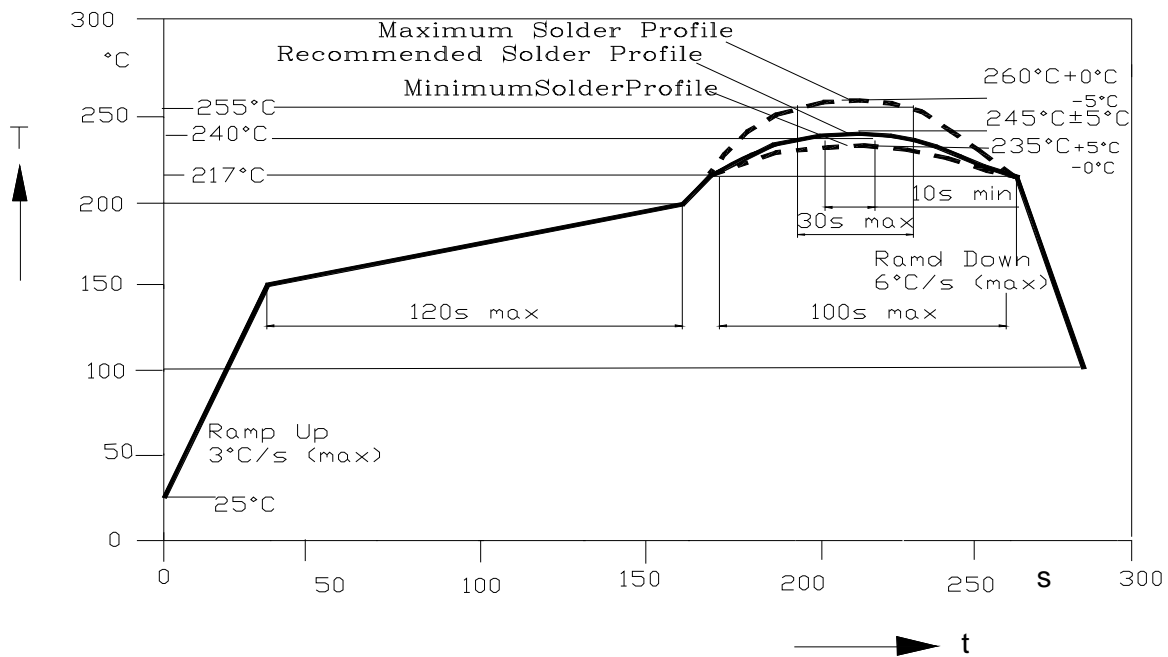



Enhance Power LED

EP501IR1L015W

REV:A/1

●Storage

1. Do not open the moisture proof bag before the devices are ready to use.
2. Before the package is opened, LED should be stored at temperatures less than 30°C and humidity less than 50%.
3. LED may be stored for 6 months. When the storage time has reached more than 6 months, LED should be stored in a sealed container filled with Nitrogen gas.
4. After the package is opened, LED should be stored at temperatures less than 30°C and humidity less than 30%.
5. LED should be used within 168 hours (7 days) after the package is opened.
6. Before using LED, baking treatment should be implemented based on the following condition: pre-curing at 60±5°C for 24 hours.

●E-Power Operating Procedure

1. E-power350 series products should be operated at 350 mA for ideal performance, but not more than 700mA.
2. E-power 350 series products must be used in conjunction with heat-sinking devices. Soldering on Al PCB with mid-connection point while keeping the layout pattern (\varnothing 19.9mm,thickness2.5mm) is another way to help heat dissipation. Thermal Resistance for aluminum board must be less than 0.65 °C/W.
3. A non-conductive heat-dissipating paste should be applied between E-power and heat-sinking device.
4. Sufficient thermal management must be applied. Large LED forward current will cause high junction temperature and reduce LED life.



Enhance Power LED

EP501IR1L015W

REV:A/1

●Reliability Test

Test Item	Test Condition	Stress Duration
Reflow	Tsol=260°C,10sec	3 times
Temperature Cycle	H:+100±5°C 15mins L: -40±5°C 15mins	300 Cycles
High Temperature High Humidity Operation	Ta=85°C±5°C RH= 90~95% IF=350mA	500 hours
High Temperature High Humidity Storage	Ta:65°C±5°C RH:90~95%RH	1000hours
Room Temperature Operation	Ta= 25±5°C IF =350mA	1000hours
Low Temperature Operation	Ta= -40±5°C IF=350mA	1000hours
High Temperature Operation	Ta= 110±5°C IF=350mA	1000hours
Salt Spray	Ta=35°C	48 hours

Temperature for using with aluminum board, in a good thermal-exchange surroundings.

Failure Criteria:

1. LED are open or shorted,
2. Radiant intensity attenuate difference(1000hours)> 30%,
3. Forward voltage difference(1000hours) >20%.

● Part NO. System of E-Power LED

EP 5 01 IR1 L 015 W

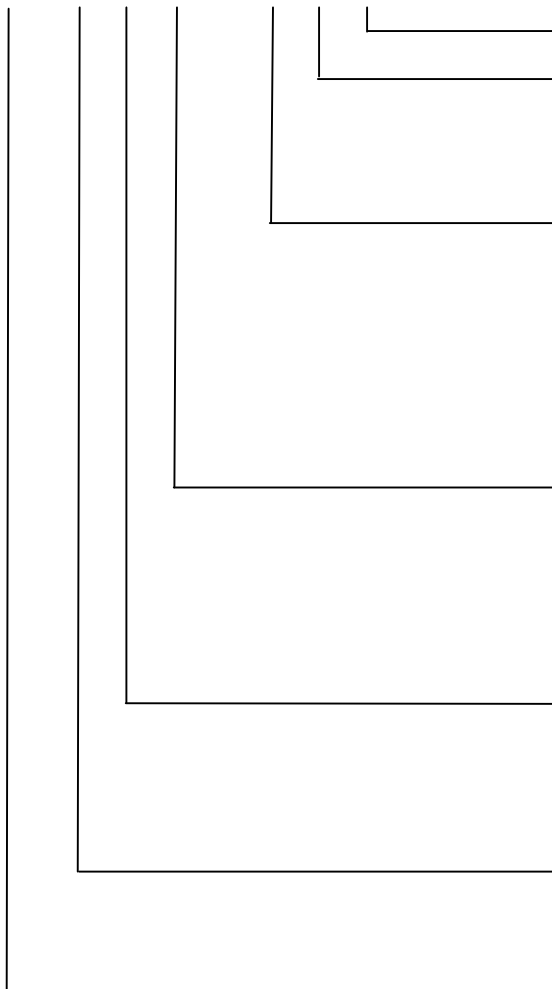

Special mark: W:white, B:black
Series Number
View Angle: 2: 2*5=10° L: L*5=130° 3: 3*5=15° M: M*5=160° 6 : 6*5=30° C: C*5=60°
R1: λ d =625nm Y1: λ d=590nm G1: λ d =525nm B1: λ d = 460nm IR: λ d =850nm A1: λ d =615nm W1: White WY: Warm white IR1: λ d =940nm
Power: 00—0.5W , 01—1W , 02—2W , 03—3W , 05—5W, ...0A-100W
PCB material: 1—Al,2—silicon,3—Fe,4—chinaware, 5—Cu
EP: Enhance Power