



# MICROCHIP MCP102/103/121/131

## Micropower Voltage Supervisors

### Features

- Ultra low supply current: 1.75  $\mu$ A (steady-state max.)
- Precision monitoring options of:
  - 1.90V, 2.32V, 2.63V, 2.93V, 3.08V, 4.38V and 4.63V
- Resets microcontroller in a power-loss event
- RST pin (Active-low):
  - **MCP121**: Active-low, open-drain
  - **MCP131**: Active-low, open-drain with internal pull-up resistor
  - **MCP102** and **MCP103**: Active-low, push-pull
- Reset Delay Timer (120 ms delay, typ.)
- Available in SOT23-3, TO-92 and SC-70 packages
- Temperature Range:
  - Extended: -40°C to +125°C (except MCP1XX-195)
  - Industrial: -40°C to +85°C (MCP1XX-195 only)
- Pb-free devices

### Applications

- Critical Microcontroller and Microprocessor Power-monitoring Applications
- Computers
- Intelligent Instruments
- Portable Battery-powered Equipment

### General Description

The MCP102/103/121/131 are voltage supervisor devices designed to keep a microcontroller in reset until the system voltage has reached and stabilized at the proper level for reliable system operation. Table 1 shows the available features for these devices.

**TABLE 1: DEVICE FEATURES**

| Device        | Output     |                            | Reset Delay (typ) | Package Pinout (Pin # 1, 2, 3)                       | Comment                                    |
|---------------|------------|----------------------------|-------------------|--|--|
|               | Type       | Pull-up Resistor           |                   |  |  |
| <b>MCP102</b> | Push-pull  | No                         | 120 ms            | RST, V <sub>DD</sub> , V <sub>SS</sub>               |  |
| <b>MCP103</b> | Push-pull  | No                         | 120 ms            | V <sub>SS</sub> , RST, V <sub>DD</sub>               |  |
| <b>MCP121</b> | Open-drain | External                   | 120 ms            | RST, V <sub>DD</sub> , V <sub>SS</sub>               |  |
| <b>MCP131</b> | Open-drain | Internal (~95 k $\Omega$ ) | 120 ms            | RST, V <sub>DD</sub> , V <sub>SS</sub>               |  |
| <b>MCP111</b> | Open-drain | External                   | No                | V <sub>OUT</sub> , V <sub>SS</sub> , V <sub>DD</sub> | See <b>MCP111/112</b> Data Sheet (DS21889) |
| <b>MCP112</b> | Push-Pull  | No                         | No                | V <sub>OUT</sub> , V <sub>SS</sub> , V <sub>DD</sub> | See <b>MCP111/112</b> Data Sheet (DS21889) |

### Package Types

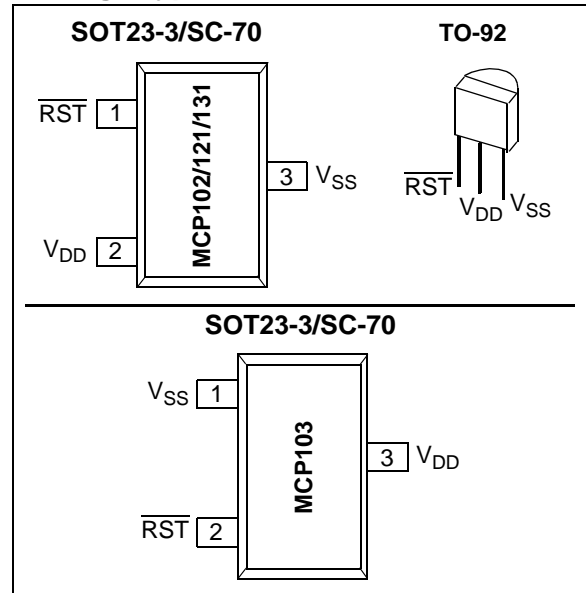

### Block Diagram

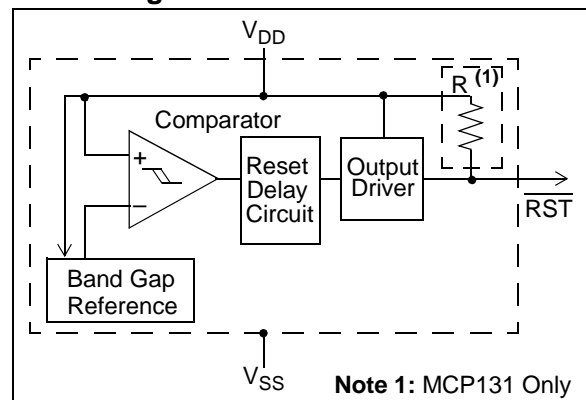

# MCP102/103/121/131

## 1.0 ELECTRICAL CHARACTERISTICS

### Absolute Maximum Ratings†

|  |                              |
|--|------------------------------|
| $V_{DD}$ .....   | 7.0V                         |
| Input current ( $V_{DD}$ ) .....   | 10 mA                        |
| Output current ( $\overline{RST}$ ) .....                                  | 10 mA                        |
| Rated Rise Time of $V_{DD}$ .....  | 100V/ $\mu$ s                |
| All inputs and outputs (except $\overline{RST}$ ) w.r.t. $V_{SS}$<br>..... | -0.6V to ( $V_{DD} + 1.0$ V) |
| $\overline{RST}$ output w.r.t. $V_{SS}$ .....                              | -0.6V to 13.5V               |
| Storage temperature .....  | -65°C to +150°C              |
| Ambient temp. with power applied .....                                     | -40°C to +125°C              |
| Maximum Junction temp. with power applied .....                            | 150°C                        |
| ESD protection on all pins .....   | $\geq 2$ kV                  |

† **Notice:** Stresses above those listed under “Maximum Ratings” may cause permanent damage to the device. This is a stress rating only and functional operation of the device at those or any other conditions above those indicated in the operational listings of this specification is not implied. Exposure to maximum rating conditions for extended periods may affect device reliability.

### DC CHARACTERISTICS

| Electrical Specifications: Unless otherwise indicated, all limits are specified for: $V_{DD} = 1$ V to 5.5V, $R_{PU} = 100$ k $\Omega$ (MCP121 only), $T_A = -40^\circ$ C to +125°C. |                              |          |     |     |       |  |   |
|--|------------------------------|----------|-----|-----|-------|--|---|
| Parameters   | Sym                          | Min      | Typ | Max | Units | Conditions   |   |
| Operating Voltage Range  | $V_{DD}$                     | 1.0      | —   | 5.5 | V     |  |   |
| Specified $V_{DD}$ Value to $\overline{RST}$ low   | $V_{DD}$                     | 1.0      | —   |     | V     | $I_{\overline{RST}} = 10$ uA, $V_{\overline{RST}} < 0.2$ V |   |
| Operating Current  | MCP102,<br>MCP103,<br>MCP121 | $I_{DD}$ | —   | < 1 | 1.75  | $\mu$ A  | Reset Power-up Timer ( $t_{RPU}$ ) Inactive   |
|  |                              |          | —   | —   | 20.0  | $\mu$ A  | Reset Power-up Timer ( $t_{RPU}$ ) Active   |
|  | MCP131                       | $I_{DD}$ | —   | < 1 | 1.75  | $\mu$ A  | $V_{DD} > V_{TRIP}$ and Reset Power-up Timer ( $t_{RPU}$ ) Inactive                   |
|  |                              |          | —   | —   | 75    | $\mu$ A  | $V_{DD} < V_{TRIP}$ and Reset Power-up Timer ( $t_{RPU}$ ) Inactive ( <b>Note 3</b> ) |
|  |                              |          | —   | —   | 90    | $\mu$ A  | Reset Power-up Timer ( $t_{RPU}$ ) Active ( <b>Note 4</b> )                           |

- Note 1:** Trip point is  $\pm 1.5\%$  from typical value.  
**Note 2:** Trip point is  $\pm 2.5\%$  from typical value.  
**Note 3:**  $\overline{RST}$  output is forced low. There is a current through the internal pull-up resistor.  
**Note 4:** This includes the current through the internal pull-up resistor and the reset power-up timer.  
**Note 5:** This specification allows this device to be used in PICmicro<sup>®</sup> microcontroller applications that require In-Circuit Serial Programming™ (ICSP™) (see device-specific programming specifications for voltage requirements). This specification DOES NOT allow a continuous high voltage to be present on the open-drain output pin ( $V_{OUT}$ ). The total time that the  $V_{OUT}$  pin can be above the maximum device operational voltage (5.5V) is 100s. Current into the  $V_{OUT}$  pin should be limited to 2 mA and it is recommended that the device operational temperature be maintained between 0°C to 70°C (+25°C preferred). For additional information, please refer to Figure 2-33.  
**Note 6:** This parameter is established by characterization and not 100% tested.

## DC CHARACTERISTICS (CONTINUED)

**Electrical Specifications:** Unless otherwise indicated, all limits are specified for:  $V_{DD} = 1V$  to  $5.5V$ ,  $R_{PU} = 100\text{ k}\Omega$  (**MCP121** only),  $T_A = -40^\circ\text{C}$  to  $+125^\circ\text{C}$ .

| Parameters  |                   | Sym               | Min                   | Typ   | Max                                      | Units  | Conditions   |
|---|-------------------|-------------------|-----------------------|-------|--|--------|--|
| V <sub>DD</sub> Trip Point  | <b>MCP1XX-195</b> | V <sub>TRIP</sub> | 1.872                 | 1.900 | 1.929                                    | V      | T <sub>A</sub> = +25°C ( <b>Note 1</b> )   |
|   |                   |                   | 1.853                 | 1.900 | 1.948                                    | V      | T <sub>A</sub> = -40°C to +85°C ( <b>Note 2</b> )  |
|   | <b>MCP1XX-240</b> |                   | 2.285                 | 2.320 | 2.355                                    | V      | T <sub>A</sub> = +25°C ( <b>Note 1</b> )   |
|   |                   |                   | 2.262                 | 2.320 | 2.378                                    | V      | <b>Note 2</b>  |
|   | <b>MCP1XX-270</b> |                   | 2.591                 | 2.630 | 2.670                                    | V      | T <sub>A</sub> = +25°C ( <b>Note 1</b> )   |
|   |                   |                   | 2.564                 | 2.630 | 2.696                                    | V      | <b>Note 2</b>  |
|   | <b>MCP1XX-300</b> |                   | 2.886                 | 2.930 | 2.974                                    | V      | T <sub>A</sub> = +25°C ( <b>Note 1</b> )   |
|   |                   |                   | 2.857                 | 2.930 | 3.003                                    | V      | <b>Note 2</b>  |
|   | <b>MCP1XX-315</b> |                   | 3.034                 | 3.080 | 3.126                                    | V      | T <sub>A</sub> = +25°C ( <b>Note 1</b> )   |
|   |                   |                   | 3.003                 | 3.080 | 3.157                                    | V      | <b>Note 2</b>  |
|   | <b>MCP1XX-450</b> |                   | 4.314                 | 4.380 | 4.446                                    | V      | T <sub>A</sub> = +25°C ( <b>Note 1</b> )   |
|   |                   |                   | 4.271                 | 4.380 | 4.490                                    | V      | <b>Note 2</b>  |
| <b>MCP1XX-475</b>   | 4.561             | 4.630             | 4.700                 | V     | T <sub>A</sub> = +25°C ( <b>Note 1</b> ) |        |  |
|   | 4.514             | 4.630             | 4.746                 | V     | <b>Note 2</b>                            |        |  |
| V <sub>DD</sub> Trip Point Tempco                                     |                   | T <sub>TPCO</sub> | —                     | ±100  | —  | ppm/°C |  |
| Threshold Hysteresis (min. = 1%, max = 6%)                            | <b>MCP1XX-195</b> | V <sub>HYS</sub>  | 0.019                 | —     | 0.114                                    | V      | T <sub>A</sub> = +25°C   |
|   | <b>MCP1XX-240</b> |                   | 0.023                 | —     | 0.139                                    | V      |  |
|   | <b>MCP1XX-270</b> |                   | 0.026                 | —     | 0.158                                    | V      |  |
|   | <b>MCP1XX-300</b> |                   | 0.029                 | —     | 0.176                                    | V      |  |
|   | <b>MCP1XX-315</b> |                   | 0.031                 | —     | 0.185                                    | V      |  |
|   | <b>MCP1XX-450</b> |                   | 0.044                 | —     | 0.263                                    | V      |  |
|   | <b>MCP1XX-475</b> |                   | 0.046                 | —     | 0.278                                    | V      |  |
| RST Low-level Output Voltage  |                   | V <sub>OL</sub>   | —                     | —     | 0.4                                      | V      | I <sub>OL</sub> = 500 μA, V <sub>DD</sub> = V <sub>TRIP(MIN)</sub>   |
| RST High-level Output Voltage ( <b>MCP102</b> and <b>MCP103</b> only) |                   | V <sub>OH</sub>   | V <sub>DD</sub> - 0.6 | —     | —  | V      | I <sub>OH</sub> = 1 mA, For <b>MCP102/MCP103</b> only (push-pull output)   |
| Internal Pull-up Resistor ( <b>MCP131</b> only)                       |                   | R <sub>PU</sub>   | —                     | 95    | —  | kΩ     | V <sub>DD</sub> = 5.5V   |
| Open-drain High Voltage on Output ( <b>MCP121</b> only)               |                   | V <sub>ODH</sub>  | —                     | —     | 13.5 <sup>(5)</sup>                      | V      | V <sub>DD</sub> = 3.0V, Time voltage > 5.5V applied ≤ 100s, current into pin limited to 2 mA, 25°C operation recommended ( <b>Note 5</b> , <b>Note 6</b> ) |
| Open-drain Output Leakage Current ( <b>MCP121</b> only)               |                   | I <sub>OD</sub>   | —                     | 0.1   | —  | μA     |  |

**Note 1:** Trip point is ±1.5% from typical value.

**Note 2:** Trip point is ±2.5% from typical value.

**Note 3:** RST output is forced low. There is a current through the internal pull-up resistor.

**Note 4:** This includes the current through the internal pull-up resistor and the reset power-up timer.

**Note 5:** This specification allows this device to be used in PICmicro<sup>®</sup> microcontroller applications that require In-Circuit Serial Programming™ (ICSP™) (see device-specific programming specifications for voltage requirements). This specification DOES NOT allow a continuous high voltage to be present on the open-drain output pin (V<sub>OUT</sub>). The total time that the V<sub>OUT</sub> pin can be above the maximum device operational voltage (5.5V) is 100s. Current into the V<sub>OUT</sub> pin should be limited to 2 mA and it is recommended that the device operational temperature be maintained between 0°C to 70°C (+25°C preferred). For additional information, please refer to Figure 2-33.

**Note 6:** This parameter is established by characterization and not 100% tested.

# MCP102/103/121/131

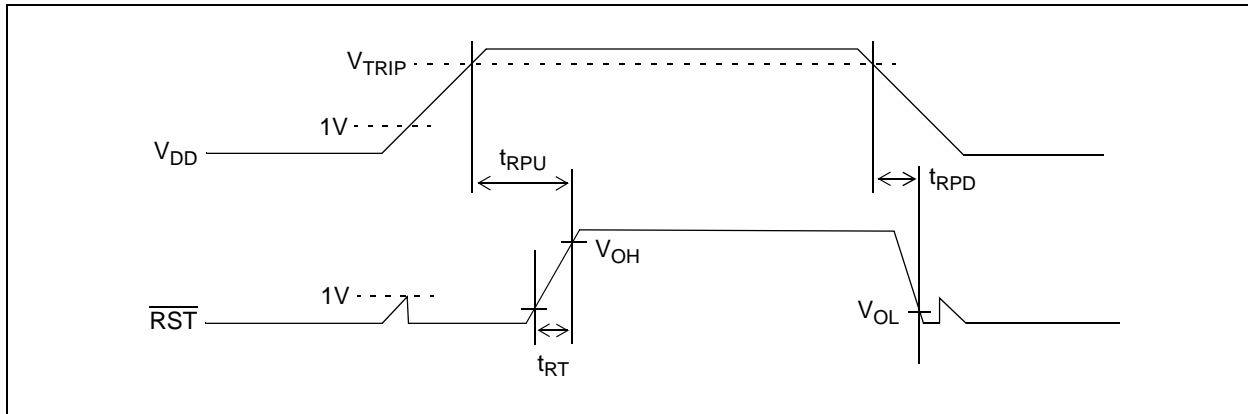

**FIGURE 1-1:** Timing Diagram.

## AC CHARACTERISTICS

**Electrical Specifications:** Unless otherwise indicated, all limits are specified for: V<sub>DD</sub> = 1V to 5.5V, R<sub>PU</sub> = 100 kΩ (MCP121 only), T<sub>A</sub> = -40°C to +125°C.

| Parameters  | Sym              | Min | Typ | Max | Units | Conditions   |
|---|------------------|-----|-----|-----|-------|--|
| V <sub>DD</sub> Detect to $\overline{\text{RST}}$ Inactive                                      | t <sub>RPU</sub> | 80  | 120 | 180 | ms    | Figure 1-1 and C <sub>L</sub> = 50 pF  |
| V <sub>DD</sub> Detect to $\overline{\text{RST}}$ Active  | t <sub>RPD</sub> | —   | 130 | —   | μs    | V <sub>DD</sub> ramped from V <sub>TRIP(MAX)</sub> + 250 mV down to V <sub>TRIP(MIN)</sub> - 250 mV, per Figure 1-1, C <sub>L</sub> = 50 pF (Note 1) |
| $\overline{\text{RST}}$ Rise Time After $\overline{\text{RST}}$ Active (MCP102 and MCP103 only) | t <sub>RT</sub>  | —   | 5   | —   | μs    | For $\overline{\text{RST}}$ 10% to 90% of final value per Figure 1-1, C <sub>L</sub> = 50 pF (Note 1)  |

**Note 1:** These parameters are for design guidance only and are not 100% tested.

## TEMPERATURE CHARACTERISTICS

**Electrical Specifications:** Unless otherwise noted, all limits are specified for: V<sub>DD</sub> = 1V to 5.5V, R<sub>PU</sub> = 100 kΩ (MCP121 only), T<sub>A</sub> = -40°C to +125°C.

| Parameters                         | Sym             | Min | Typ   | Max  | Units | Conditions        |
|------------------------------------|-----------------|-----|-------|------|-------|-------------------|
| <b>Temperature Ranges</b>          |                 |     |       |      |       |                   |
| Specified Temperature Range        | T <sub>A</sub>  | -40 | —     | +85  | °C    | MCP1XX-195        |
| Specified Temperature Range        | T <sub>A</sub>  | -40 | —     | +125 | °C    | Except MCP1XX-195 |
| Maximum Junction Temperature       | T <sub>J</sub>  | —   | —     | +150 | °C    |                   |
| Storage Temperature Range          | T <sub>A</sub>  | -65 | —     | +150 | °C    |                   |
| <b>Package Thermal Resistances</b> |                 |     |       |      |       |                   |
| Thermal Resistance, 3L-SOT23       | θ <sub>JA</sub> | —   | 336   | —    | °C/W  |                   |
| Thermal Resistance, 3L-SC-70       | θ <sub>JA</sub> | —   | 340   | —    | °C/W  |                   |
| Thermal Resistance, 3L-TO-92       | θ <sub>JA</sub> | —   | 131.9 | —    | °C/W  |                   |

## 2.0 TYPICAL PERFORMANCE CURVES

**Note:** The graphs and tables provided following this note are a statistical summary based on a limited number of samples and are provided for informational purposes only. The performance characteristics listed herein are not tested or guaranteed. In some graphs or tables, the data presented may be outside the specified operating range (e.g., outside specified power supply range) and therefore outside the warranted range.

**Note:** Unless otherwise indicated, all limits are specified for:  $V_{DD} = 1V$  to  $5.5V$ ,  $R_{PU} = 100\text{ k}\Omega$  (MCP121 only; see Figure 4-1),  $T_A = -40^\circ\text{C}$  to  $+125^\circ\text{C}$ .

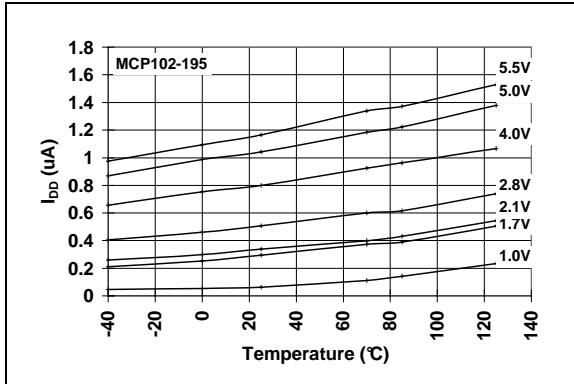

**FIGURE 2-1:**  $I_{DD}$  vs. Temperature (Reset Power-up Timer Inactive) (MCP102-195).

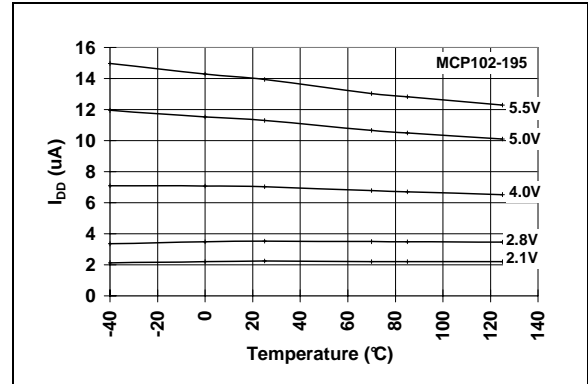

**FIGURE 2-4:**  $I_{DD}$  vs. Temperature (Reset Power-up Timer Active) (MCP102-195).

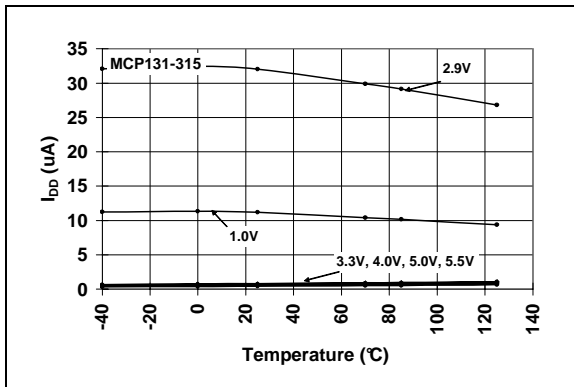

**FIGURE 2-2:**  $I_{DD}$  vs. Temperature (Reset Power-up Timer Inactive) (MCP131-315).

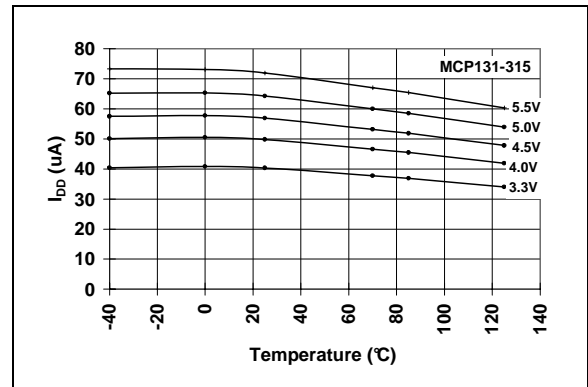

**FIGURE 2-5:**  $I_{DD}$  vs. Temperature (Reset Power-up Timer Active) (MCP131-315).

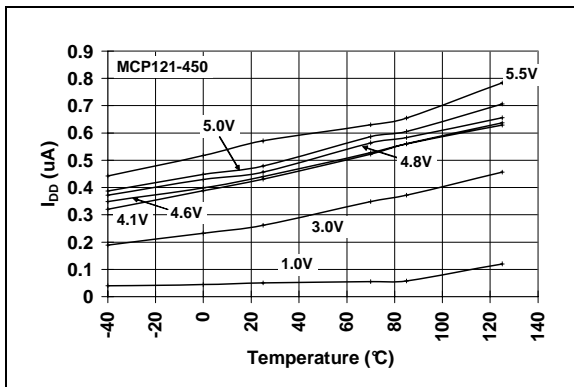

**FIGURE 2-3:**  $I_{DD}$  vs. Temperature (Reset Power-up Timer Inactive) (MCP121-450).

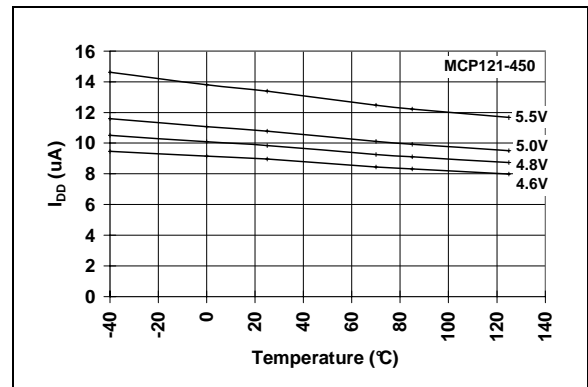

**FIGURE 2-6:**  $I_{DD}$  vs. Temperature (Reset Power-up Timer Active) (MCP121-450).

# MCP102/103/121/131

**Note:** Unless otherwise indicated, all limits are specified for:  $V_{DD} = 1V$  to  $5.5V$ ,  $R_{PU} = 100\text{ k}\Omega$  (MCP121 only; see Figure 4-1),  $T_A = -40^\circ\text{C}$  to  $+125^\circ\text{C}$ .

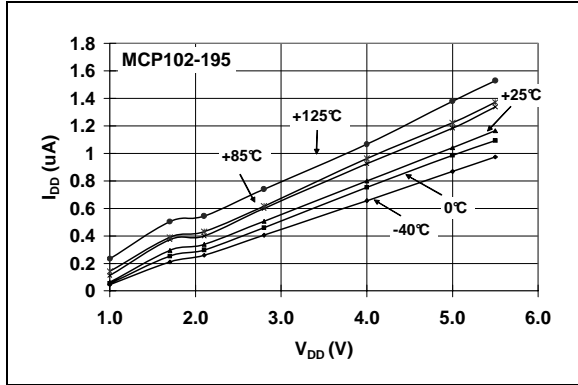

**FIGURE 2-7:**  $I_{DD}$  vs.  $V_{DD}$   
(Reset Power-up Timer Inactive) (MCP102-195).

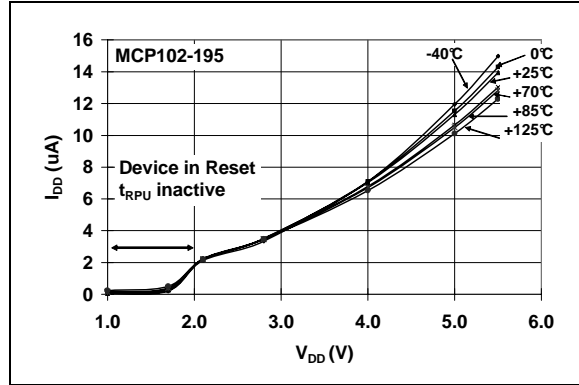

**FIGURE 2-10:**  $I_{DD}$  vs.  $V_{DD}$   
(Reset Power-up Timer Active) (MCP102-195).

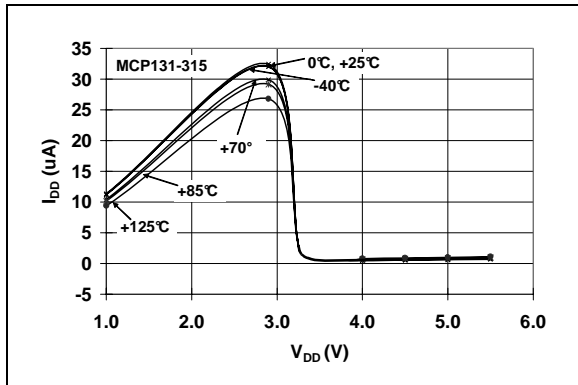

**FIGURE 2-8:**  $I_{DD}$  vs.  $V_{DD}$   
(Reset Power-up Timer Inactive) (MCP131-315).

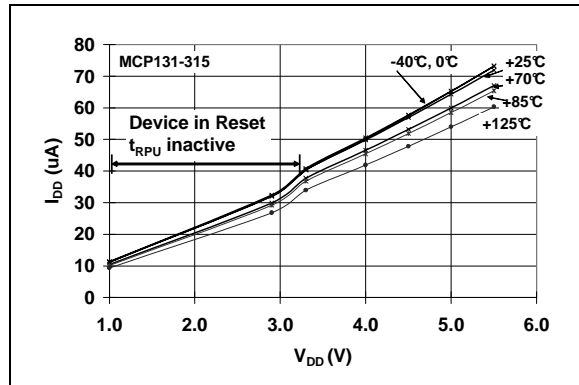

**FIGURE 2-11:**  $I_{DD}$  vs.  $V_{DD}$   
(Reset Power-up Timer Active) (MCP131-315).

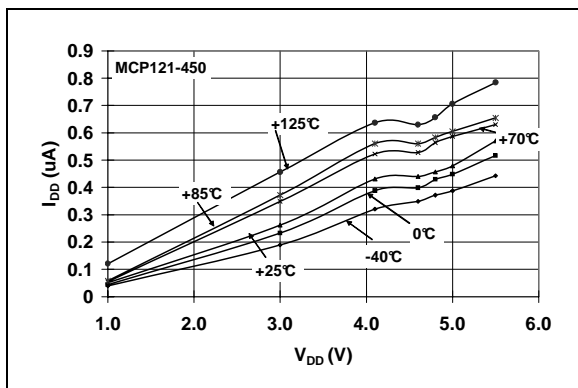

**FIGURE 2-9:**  $I_{DD}$  vs.  $V_{DD}$   
(Reset Power-up Timer Inactive) (MCP121-450).

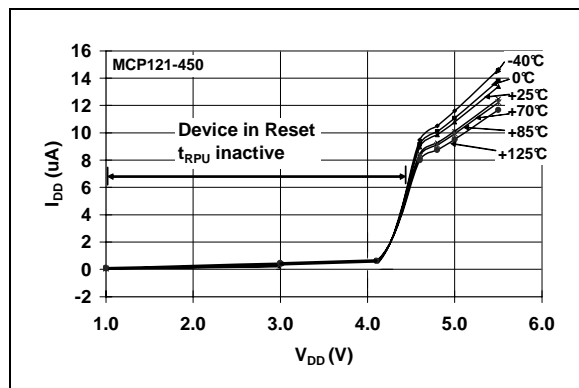

**FIGURE 2-12:**  $I_{DD}$  vs.  $V_{DD}$   
(Reset Power-up Timer Active) (MCP121-450).

# MCP102/103/121/131

**Note:** Unless otherwise indicated, all limits are specified for:  $V_{DD} = 1V$  to  $5.5V$ ,  $R_{PU} = 100\text{ k}\Omega$  (MCP121; see Figure 4-1),  $T_A = -40^\circ\text{C}$  to  $+125^\circ\text{C}$ .

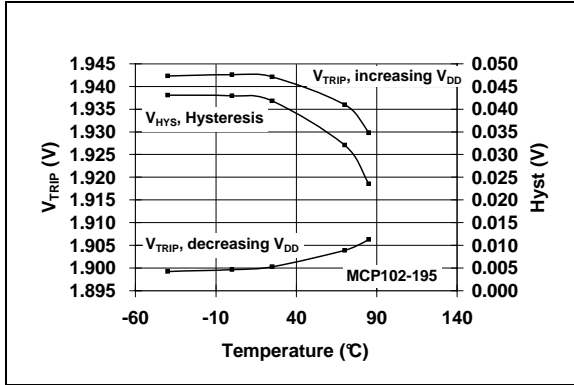

**FIGURE 2-13:**  $V_{TRIP}$  vs. Temperature vs. Hysteresis (MCP102-195).

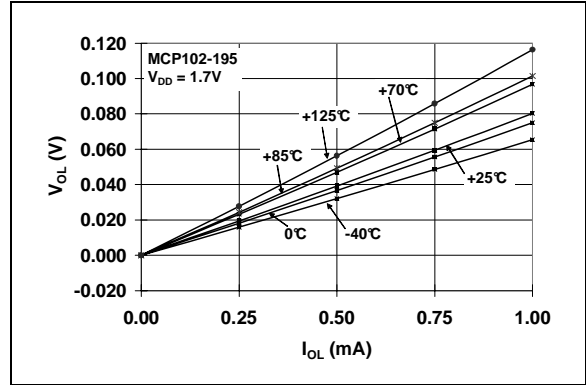

**FIGURE 2-16:**  $V_{OL}$  vs.  $I_{OL}$  (MCP102-195 @  $V_{DD} = 1.7V$ ).

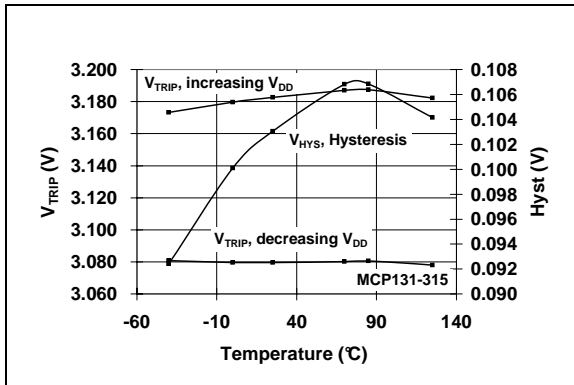

**FIGURE 2-14:**  $V_{TRIP}$  vs. Temperature vs. Hysteresis (MCP131-315).

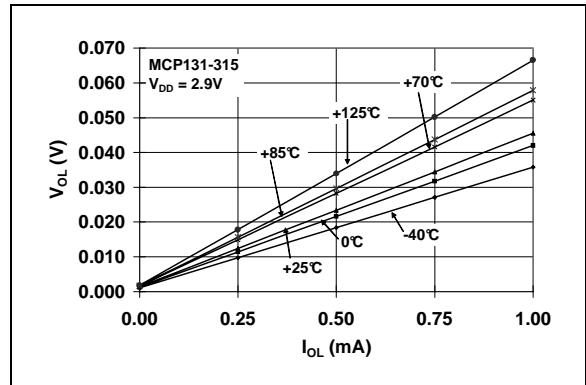

**FIGURE 2-17:**  $V_{OL}$  vs.  $I_{OL}$  (MCP131-315 @  $V_{DD} = 2.9V$ ).

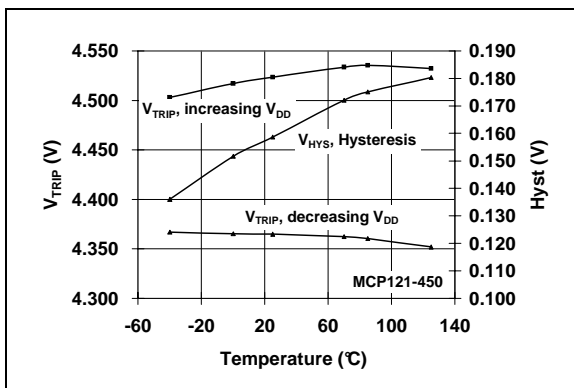

**FIGURE 2-15:**  $V_{TRIP}$  vs. Temperature vs. Hysteresis (MCP121-450).

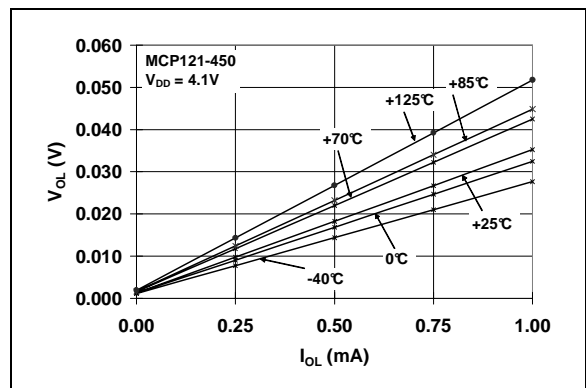

**FIGURE 2-18:**  $V_{OL}$  vs.  $I_{OL}$  (MCP121-450 @  $V_{DD} = 4.1V$ ).

# MCP102/103/121/131

**Note:** Unless otherwise indicated, all limits are specified for:  $V_{DD} = 1V$  to  $5.5V$ ,  $R_{PU} = 100\text{ k}\Omega$  (MCP121 only; see Figure 4-1),  $T_A = -40^\circ\text{C}$  to  $+125^\circ\text{C}$ .

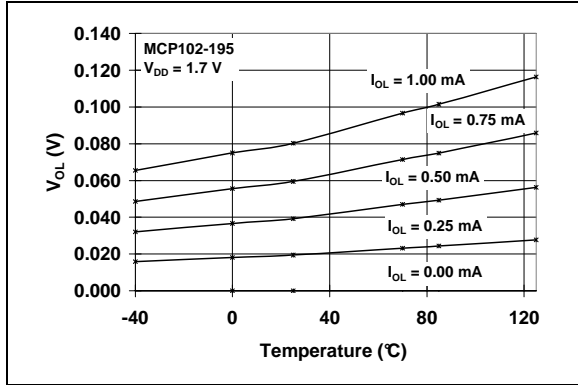

**FIGURE 2-19:**  $V_{OL}$  vs. Temperature (MCP102-195 @  $V_{DD} = 1.7V$ ).

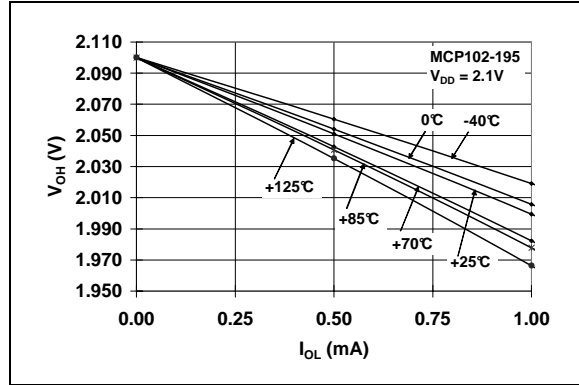

**FIGURE 2-22:**  $V_{OH}$  vs.  $I_{OL}$  (MCP102-195 @  $V_{DD} = 2.1V$ ).

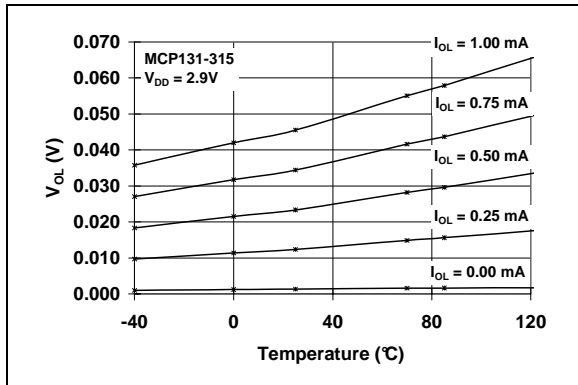

**FIGURE 2-20:**  $V_{OL}$  vs. Temperature (MCP131-315 @  $V_{DD} = 2.9V$ ).

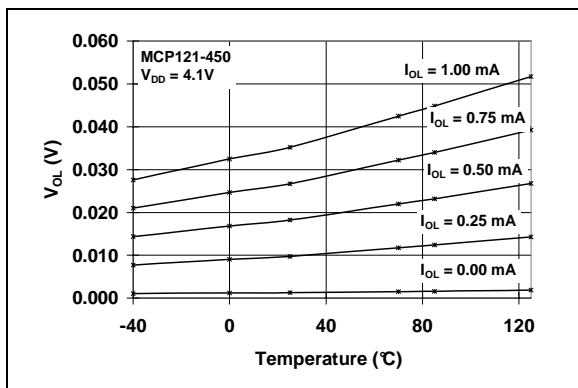

**FIGURE 2-21:**  $V_{OL}$  vs. Temperature (MCP121-450 @  $V_{DD} = 4.1V$ ).

# MCP102/103/121/131

**Note:** Unless otherwise indicated, all limits are specified for:  $V_{DD} = 1V$  to  $5.5V$ ,  $R_{PU} = 100\text{ k}\Omega$  (MCP121 only; see Figure 4-1),  $T_A = -40^\circ\text{C}$  to  $+125^\circ\text{C}$ .

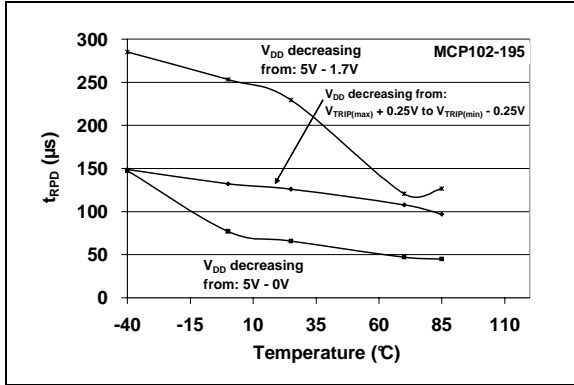

**FIGURE 2-23:**  $t_{RPD}$  vs. Temperature (MCP102-195).

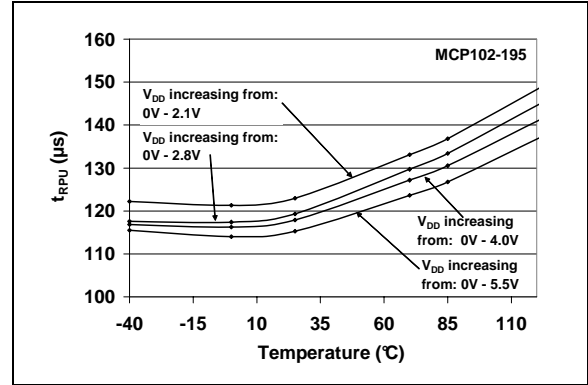

**FIGURE 2-26:**  $t_{RPU}$  vs. Temperature (MCP102-195).

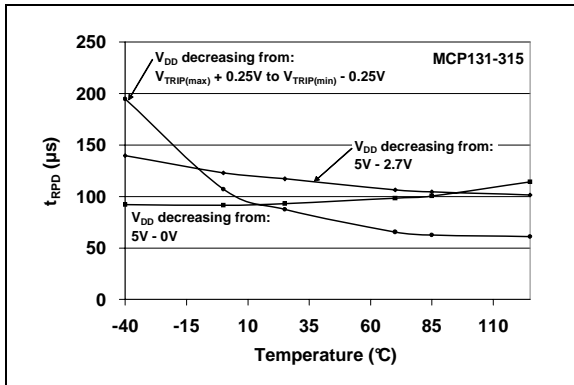

**FIGURE 2-24:**  $t_{RPD}$  vs. Temperature (MCP131-315).

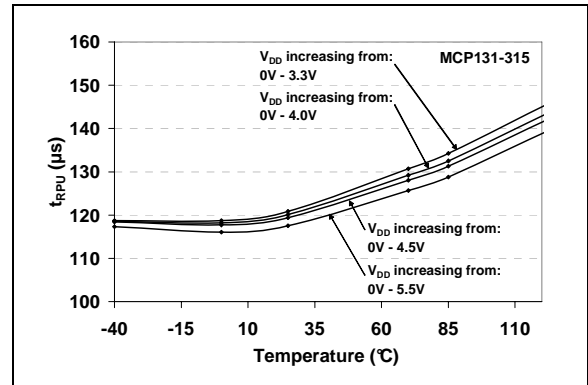

**FIGURE 2-27:**  $t_{RPU}$  vs. Temperature (MCP131-315).

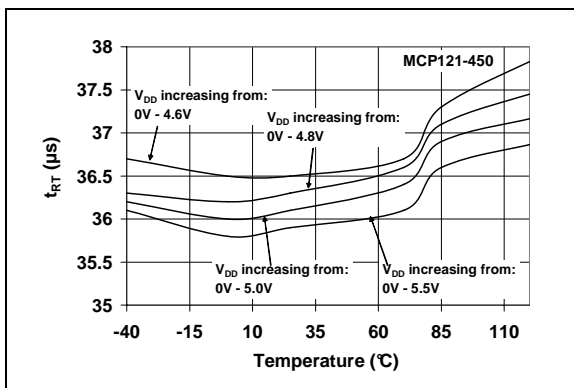

**FIGURE 2-25:**  $t_{RPD}$  vs. Temperature (MCP121-450).

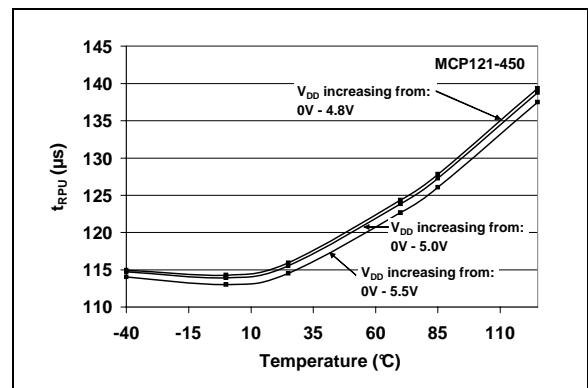

**FIGURE 2-28:**  $t_{RPU}$  vs. Temperature (MCP121-450).

# MCP102/103/121/131

**Note:** Unless otherwise indicated, all limits are specified for:  $V_{DD} = 1V$  to  $5.5V$ ,  $R_{PU} = 100\text{ k}\Omega$  (MCP121 only; see Figure 4-1),  $T_A = -40^\circ\text{C}$  to  $+125^\circ\text{C}$ .

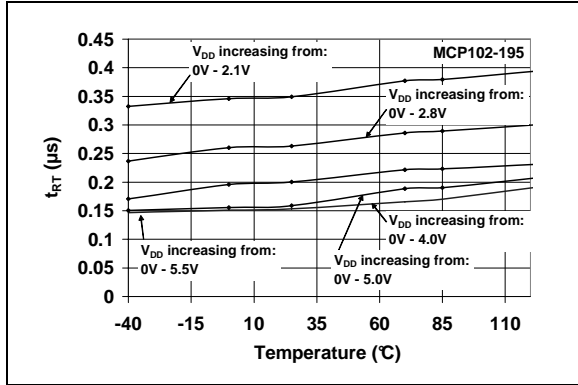

**FIGURE 2-29:**  $t_{RT}$  vs. Temperature (MCP102-195).

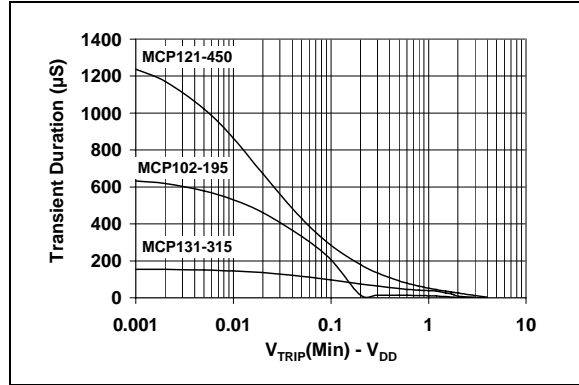

**FIGURE 2-32:** Transient Duration vs.  $V_{TRIP}(\text{min}) - V_{DD}$ .

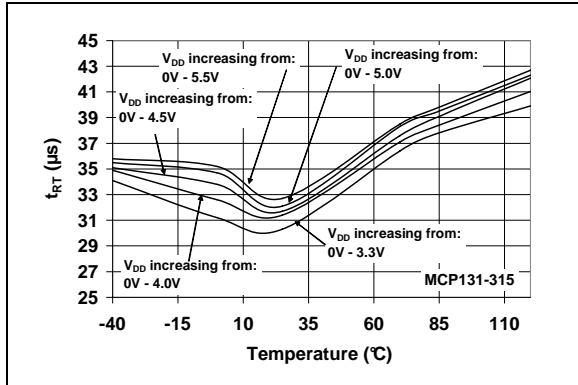

**FIGURE 2-30:**  $t_{RT}$  vs. Temperature (MCP131-315).

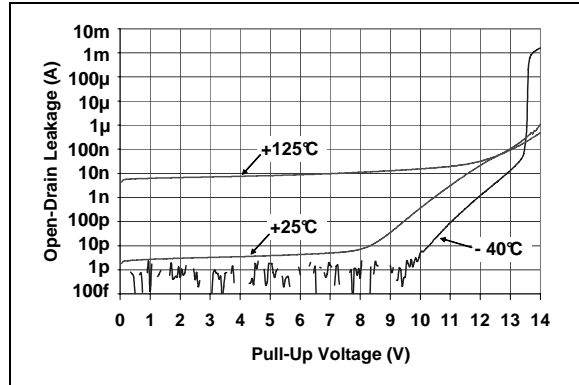

**FIGURE 2-33:** Open-Drain Leakage Current vs. Voltage Applied to  $V_{OUT}$  Pin (MCP121-195).

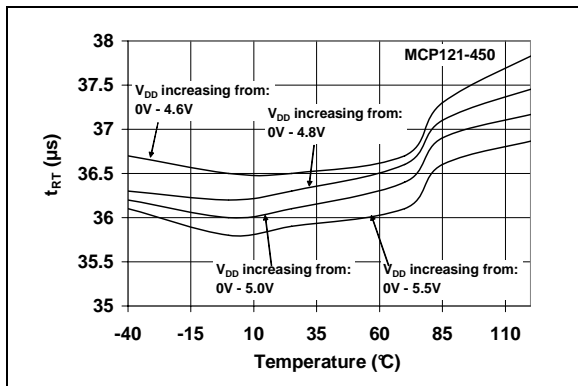

**FIGURE 2-31:**  $t_{RT}$  vs. Temperature (MCP121-450).

## 3.0 PIN DESCRIPTION

The descriptions of the pins are listed in Table 3-1.

**TABLE 3-1: PIN FUNCTION TABLE**

| Pin No.                    |        | Symbol                  | Function  |
|----------------------------|--------|-------------------------|---|
| MCP102<br>MCP121<br>MCP131 | MCP103 |                         |   |
| 1                          | 1      | $\overline{\text{RST}}$ | Output State<br><b>V<sub>DD</sub> Falling:</b><br>$H = V_{DD} > V_{TRIP}$<br>$L = V_{DD} < V_{TRIP}$<br><br><b>V<sub>DD</sub> Rising:</b><br>$H = V_{DD} > V_{TRIP} + V_{HYS}$<br>$L = V_{DD} < V_{TRIP} + V_{HYS}$ |
| 2                          | 3      | V <sub>DD</sub>         | Positive power supply   |
| 3                          | 2      | V <sub>SS</sub>         | Ground reference  |

# MCP102/103/121/131

## 4.0 APPLICATION INFORMATION

For many of today's microcontroller applications, care must be taken to prevent low-power conditions that can cause many different system problems. The most common causes are brown-out conditions, where the system supply drops below the operating level momentarily. The second most common cause is when a slowly decaying power supply causes the microcontroller to begin executing instructions without sufficient voltage to sustain volatile memory (RAM), thus producing indeterminate results. Figure 4-1 shows a typical application circuit.

The MCP102/103/121/131 are voltage supervisor devices designed to keep a microcontroller in reset until the system voltage has reached and stabilized at the proper level for reliable system operation. These devices also operate as protection from brown-out conditions.

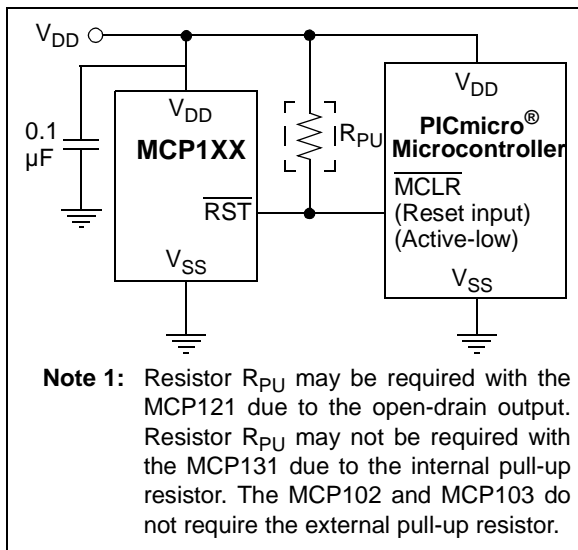

FIGURE 4-1: Typical Application Circuit.

## 4.1 $\overline{RST}$ Operation

The  $\overline{RST}$  output pin operation determines how the device can be used and indicates when the system should be forced into reset. To accomplish this, an internal voltage reference is used to set the voltage trip point ( $V_{TRIP}$ ). Additionally, there is a hysteresis on this trip point.

When the falling edge of  $V_{DD}$  crosses this voltage threshold, the reset power-down timer ( $T_{RPD}$ ) starts. When this delay timer times out, the  $\overline{RST}$  pin is forced low.

When the rising-edge of  $V_{DD}$  crosses this voltage threshold, the reset power-up timer ( $T_{RPU}$ ) starts. When this delay timer times out, the  $\overline{RST}$  pin is forced high,  $T_{RPU}$  is active and there is additional system current.

The actual voltage trip point ( $V_{TRIPAC}$ ) will be between the minimum trip point ( $V_{TRIPMIN}$ ) and the maximum trip point ( $V_{TRIPMAX}$ ). The hysteresis on this trip point and the delay timer ( $T_{RPU}$ ) are to remove any "jitter" that would occur on the  $\overline{RST}$  pin when the device  $V_{DD}$  is at the trip point.

Figure 4-2 shows the waveform of the  $\overline{RST}$  pin as determined by the  $V_{DD}$  voltage, while Table 4-1 shows the state of the  $\overline{RST}$  pin. The  $V_{TRIP}$  specification is for falling  $V_{DD}$  voltages. When the  $V_{DD}$  voltage is rising, the  $\overline{RST}$  will not be driven high until  $V_{DD}$  is at  $V_{TRIP} + V_{HYS}$ . Once  $V_{DD}$  has crossed the voltage trip point, there is also a minimal delay time ( $T_{RPD}$ ) before the  $\overline{RST}$  pin is driven low.

TABLE 4-1:  $\overline{RST}$  PIN STATES

| Device | State of $\overline{RST}$ Pin when: |                               | Output Driver  |
|--------|-------------------------------------|-------------------------------|----------------|
|        | $V_{DD} < V_{TRIP}$                 | $V_{DD} > V_{TRIP} + V_{HYS}$ |                |
| MCP102 | L                                   | H                             | Push-pull      |
| MCP103 | L                                   | H                             | Push-pull      |
| MCP121 | L                                   | H (1)                         | Open-drain (1) |
| MCP131 | L                                   | H (2)                         | Open-drain (2) |

**Note 1:** Requires External Pull-up resistor

**2:** Has Internal Pull-up resistor

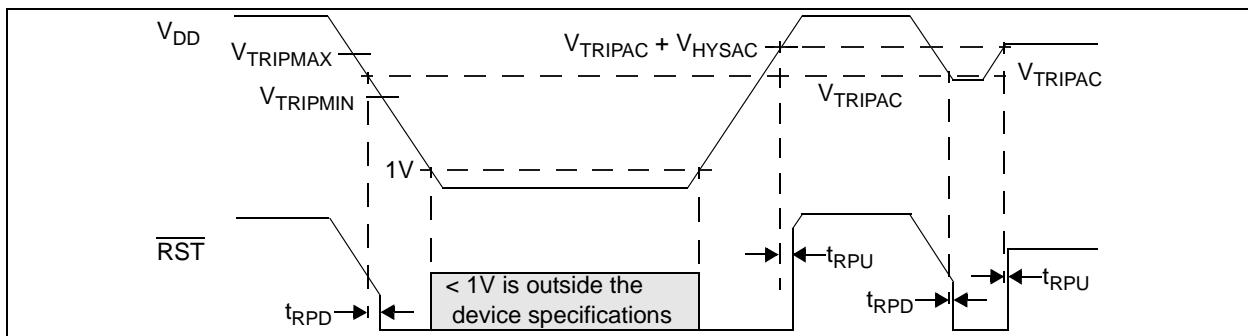

FIGURE 4-2:  $\overline{RST}$  Operation as Determined by the  $V_{TRIP}$  and  $V_{HYS}$ .

## 4.2 Negative Going $V_{DD}$ Transients

The minimum pulse width (time) required to cause a reset may be an important criteria in the implementation of a Power-on Reset (POR) circuit. This time is referred to as transient duration, defined as the amount of time needed for these supervisory devices to respond to a drop in  $V_{DD}$ . The transient duration time is dependant on the magnitude of  $V_{TRIP} - V_{DD}$ . Generally speaking, the transient duration decreases with increases in  $V_{TRIP} - V_{DD}$ .

Figure 4-3 shows a typical transient duration vs. reset comparator overdrive, for which the MCP102/103/121/131 will not generate a reset pulse. It shows that the farther below the trip point the transient pulse goes, the duration of the pulse required to cause a reset gets shorter. Figure 2-32 shows the transient response characteristics for the MCP102/103/121/131.

A 0.1  $\mu\text{F}$  bypass capacitor, mounted as close as possible to the  $V_{DD}$  pin, provides additional transient immunity (refer to Figure 4-1).

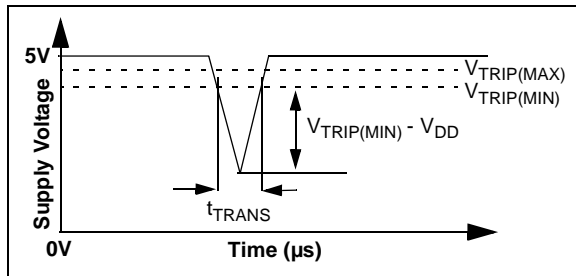

**FIGURE 4-3:** Example of Typical Transient Duration Waveform.

## 4.3 Reset Power-up Timer ( $t_{RPU}$ )

Figure 4-4 illustrates the device current states. While the system is powering down, the device has a low current. This current is dependent on the device  $V_{DD}$  and trip point. When the device  $V_{DD}$  rises through the voltage trip point ( $V_{TRIP}$ ), an internal timer starts. This timer consumes additional current until the  $\overline{\text{RST}}$  pin is driven (or released) high. This time is known as the Reset Power-up Time ( $t_{RPU}$ ). Figure 4-4 shows when  $t_{RPU}$  is active (device consuming additional current).

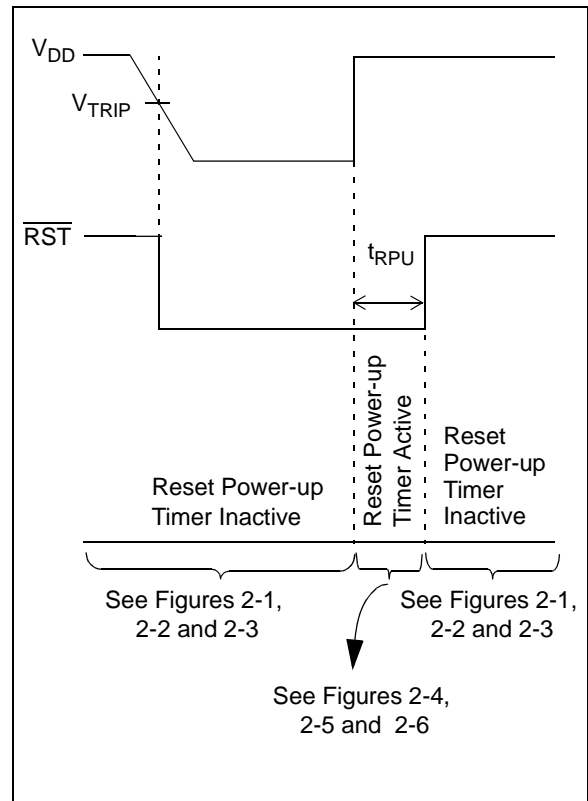

**FIGURE 4-4:** Reset Power-up Timer Waveform.

### 4.3.1 EFFECT OF TEMPERATURE ON RESET POWER-UP TIMER ( $T_{RPU}$ )

The Reset Power-up timer time-out period ( $t_{RPU}$ ) determines how long the device remains in the reset condition. This is affected by both  $V_{DD}$  and temperature. Typical responses for different  $V_{DD}$  values and temperatures are shown in Figures 2-26, 2-27 and 2-28.

# MCP102/103/121/131

## 4.4 Using in PICmicro<sup>®</sup> Microcontroller, ICSP<sup>™</sup> Applications (MCP121 only)

Figure 4-5 shows the typical application circuit for using the MCP121 for voltage supervisory function when the PICmicro microcontroller will be programmed via the ICSP feature. Additional information is available in TB087, "Using Voltage Supervisors with PICmicro<sup>®</sup> Microcontroller Systems which Implement In-Circuit Serial Programming<sup>™</sup>", DS91087.

**Note:** It is recommended that the current into the  $\overline{\text{RST}}$  pin be current limited by a 1 k $\Omega$  resistor.

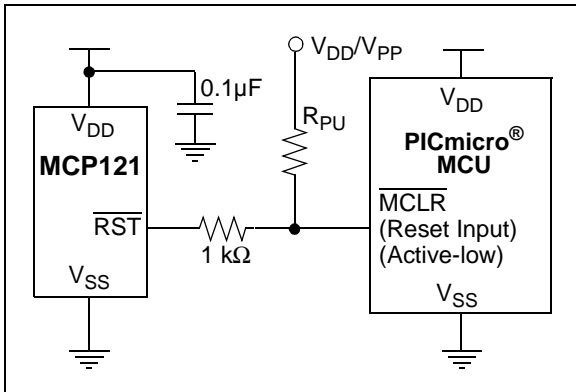
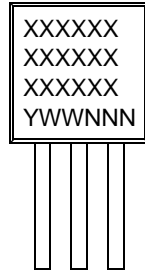

**FIGURE 4-5:** Typical Application Circuit for PICmicro<sup>®</sup> Microcontroller with the ICSP<sup>™</sup> feature.

## 5.0 PACKAGING INFORMATION

### 5.1 Package Marking Information

3-Lead TO-92



Example:

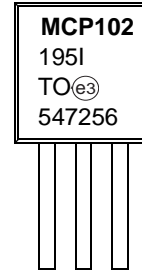

3-Pin SOT-23

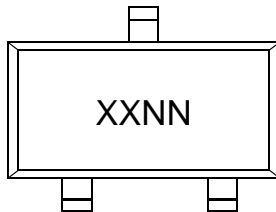

Example:

| Part Number     | MCP1xx = |        |        |        |
|-----------------|----------|--------|--------|--------|
|                 | MCP102   | MCP103 | MCP121 | MCP131 |
| MCP1xxT-195I/TT | JGNN     | TGNN   | LGNN   | KGNN   |
| MCP1xxT-240ETT  | JHNN     | THNN   | LHNN   | KHNN   |
| MCP1xxT-270E/TT | JJNN     | TJNN   | LJNN   | KJNN   |
| MCP1xxT-300E/TT | JKNN     | TKNN   | LKNN   | KKNN   |
| MCP1xxT-315E/TT | JLNN     | TLNN   | LLNN   | KLNN   |
| MCP1xxT-450E/TT | JMNN     | TMNN   | LMNN   | KMNN   |
| MCP1xxT-475E/TT | JPNN     | TPNN   | LPNN   | KPNN   |

|                |        |  |
|----------------|--------|--|
| <b>Legend:</b> | XX...X | Customer-specific information  |
|                | Y      | Year code (last digit of calendar year)  |
|                | WW     | Week code (week of January 1 is week '01')   |
|                | NNN    | Alphanumeric traceability code   |
|                | (e3)   | Pb-free JEDEC designator for Matte Tin (Sn)  |
|                | *      | This package is Pb-free. The Pb-free JEDEC designator (e3) can be found on the outer packaging for this package. |

**Note:** In the event the full Microchip part number cannot be marked on one line, it will be carried over to the next line, thus limiting the number of available characters for customer-specific information.

# MCP102/103/121/131

## Package Marking Information (Continued)

3-Pin SC-70

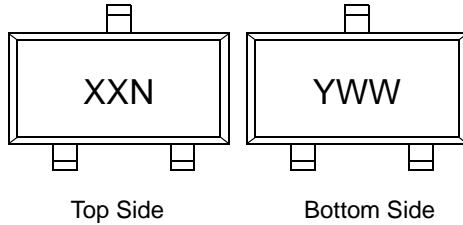

Example:

| Part Number                  | MCP1xx =      |               |               |               |
|------------------------------|---------------|---------------|---------------|---------------|
|                              | <u>MCP102</u> | <u>MCP103</u> | <u>MCP121</u> | <u>MCP131</u> |
| MCP1 <del>xx</del> T-195I/LB | BGN           | FGN           | DGN           | CGN           |
| MCP1 <del>xx</del> T-240E/LB | BHN           | FHN           | DHN           | CHN           |
| MCP1 <del>xx</del> T-270E/LB | BJN           | FJN           | DJN           | CJN           |
| MCP1 <del>xx</del> T-300E/LB | BKN           | FKN           | DKN           | CKN           |
| MCP1 <del>xx</del> T-315E/LB | BLN           | FLN           | DLN           | CLN           |
| MCP1 <del>xx</del> T-450E/LB | BMN           | FMN           | DMN           | CMN           |
| MCP1 <del>xx</del> T-475E/LB | BPN           | FPN           | DPN           | CPN           |

OR

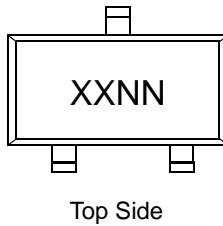

Example:

| Part Number                  | MCP1xx =      |               |               |               |
|------------------------------|---------------|---------------|---------------|---------------|
|                              | <u>MCP102</u> | <u>MCP103</u> | <u>MCP121</u> | <u>MCP131</u> |
| MCP1 <del>xx</del> T-195I/LB | BGNN          | FGNN          | DGNN          | CGNN          |
| MCP1 <del>xx</del> T-240E/LB | BHNN          | FHNN          | DHNN          | CHNN          |
| MCP1 <del>xx</del> T-270E/LB | BJNN          | FJNN          | DJNN          | CJNN          |
| MCP1 <del>xx</del> T-300E/LB | BKNN          | FKNN          | DKNN          | CKNN          |
| MCP1 <del>xx</del> T-315E/LB | BLNN          | FLNN          | DLNN          | CLNN          |
| MCP1 <del>xx</del> T-450E/LB | BMNN          | FMNN          | DMNN          | CMNN          |
| MCP1 <del>xx</del> T-475E/LB | BPNN          | FPNN          | DPNN          | CPNN          |

# MCP102/103/121/131

## 3-Lead Plastic Small Outline Transistor (TT) (SOT-23)

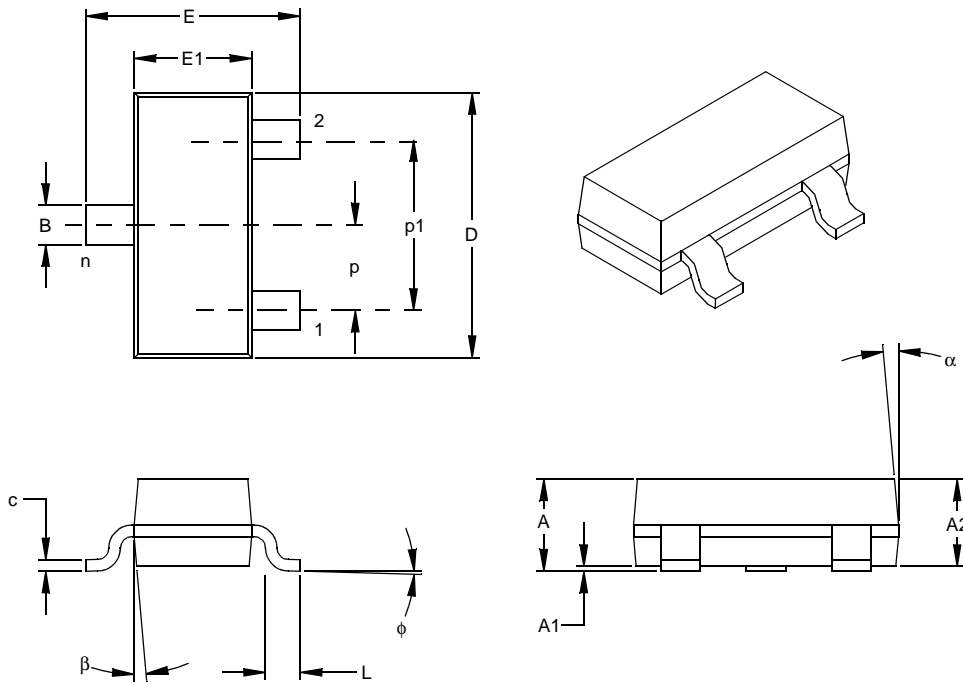

| Units                      |        | INCHES* |      |      | MILLIMETERS |      |      |
|----------------------------|--------|---------|------|------|-------------|------|------|
| Dimension                  | Limits | MIN     | NOM  | MAX  | MIN         | NOM  | MAX  |
| Number of Pins             | n      |         | 3    |      |             | 3    |      |
| Pitch                      | p      |         | .038 |      |             | 0.96 |      |
| Outside lead pitch (basic) | p1     |         | .076 |      |             | 1.92 |      |
| Overall Height             | A      | .035    | .040 | .044 | 0.89        | 1.01 | 1.12 |
| Molded Package Thickness   | A2     | .035    | .037 | .040 | 0.88        | 0.95 | 1.02 |
| Standoff §                 | A1     | .000    | .002 | .004 | 0.01        | 0.06 | 0.10 |
| Overall Width              | E      | .083    | .093 | .104 | 2.10        | 2.37 | 2.64 |
| Molded Package Width       | E1     | .047    | .051 | .055 | 1.20        | 1.30 | 1.40 |
| Overall Length             | D      | .110    | .115 | .120 | 2.80        | 2.92 | 3.04 |
| Foot Length                | L      | .014    | .018 | .022 | 0.35        | 0.45 | 0.55 |
| Foot Angle                 | φ      | 0       | 5    | 10   | 0           | 5    | 10   |
| Lead Thickness             | c      | .004    | .006 | .007 | 0.09        | 0.14 | 0.18 |
| Lead Width                 | B      | .015    | .017 | .020 | 0.37        | 0.44 | 0.51 |
| Mold Draft Angle Top       | α      | 0       | 5    | 10   | 0           | 5    | 10   |
| Mold Draft Angle Bottom    | β      | 0       | 5    | 10   | 0           | 5    | 10   |

\* Controlling Parameter  
 § Significant Characteristic

Notes:

Dimensions D and E1 do not include mold flash or protrusions. Mold flash or protrusions shall not exceed .010" (0.254mm) per side.

JEDEC Equivalent: TO-236  
 Drawing No. C04-104

# MCP102/103/121/131

## 3-Lead Plastic Small Outline Transistor (LB) (SC-70)

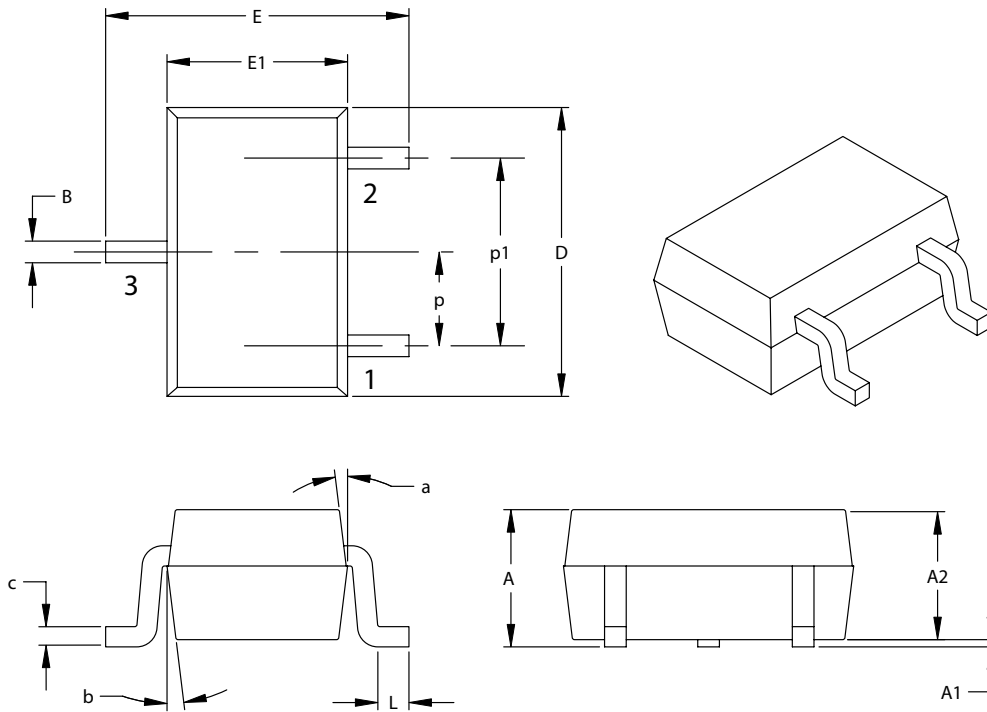

| Dimension Limits           | Units | INCHES    |       | MILLIMETERS* |      |
|----------------------------|-------|-----------|-------|--------------|------|
|                            |       | MIN       | MAX   | MIN          | MAX  |
| Number of Pins             |       | 3         |       | 3            |      |
| Pitch                      | P     | .026 BSC. |       | 0.65 BSC.    |      |
| Outside lead pitch (basic) | p1    | .051 BSC. |       | 1.30 BSC.    |      |
| Overall Height             | A     | .031      | .043  | 0.80         | 1.10 |
| Molded Package Thickness   | A2    | .031      | .039  | 0.80         | 1.00 |
| Standoff                   | A1    | .000      | .0004 | 0.00         | .010 |
| Overall Width              | E     | .071      | .094  | 1.80         | 2.40 |
| Molded Package Width       | E1    | .045      | .053  | 1.15         | 1.35 |
| Overall Length             | D     | .071      | .089  | 1.80         | 2.25 |
| Foot Length                | L     | .004      | .016  | 0.10         | 0.41 |
| Lead Thickness             | c     | .003      | .010  | 0.08         | 0.25 |
| Lead Width                 | B     | .006      | .016  | 0.15         | 0.40 |
| Mold Draft Angle Top       | a     | 8°        | 12°   | 8°           | 12°  |
| Mold Draft Angle Bottom    | b     | 8°        | 12°   | 8°           | 12°  |

\*Controlling Parameter

Notes:

Dimensions D and E1 do not include mold flash or protrusions. Mold flash or protrusions shall not exceed .005" (0.127mm) per side.

JEITA (EIAJ) Equivalent: SC70

Drawing No. C04-104



# MCP102/103/121/131

## 5.2 Product Tape and Reel Specifications

**FIGURE 5-1: EMBOSSED CARRIER DIMENSIONS (8, 12, 16 AND 24 MM TAPE ONLY)**

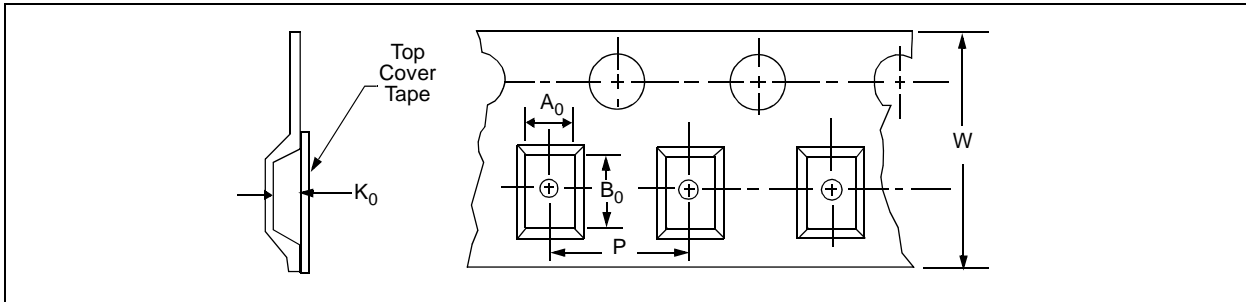

**TABLE 1: CARRIER TAPE/CAVITY DIMENSIONS**

| Case Outline | Package Type |    | Carrier Dimensions |      | Cavity Dimensions |       |       | Output Quantity Units | Reel Diameter in mm |
|--------------|--------------|----|--------------------|------|-------------------|-------|-------|-----------------------|---------------------|
|              |              |    | W mm               | P mm | A0 mm             | B0 mm | K0 mm |                       |                     |
| TT           | SOT-23       | 3L | 8                  | 4    | 3.15              | 2.77  | 1.22  | 3000                  | 180                 |
| LB           | SC-70        | 3L | 8                  | 4    | 2.4               | 2.4   | 1.19  | 3000                  | 180                 |

**FIGURE 5-2: 3-LEAD SOT-23/SC70 DEVICE TAPE AND REEL SPECIFICATIONS**

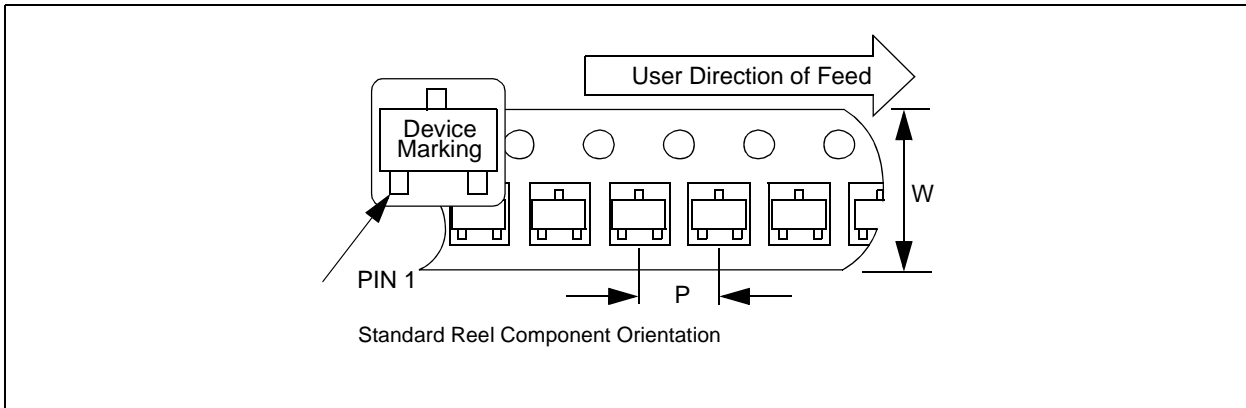
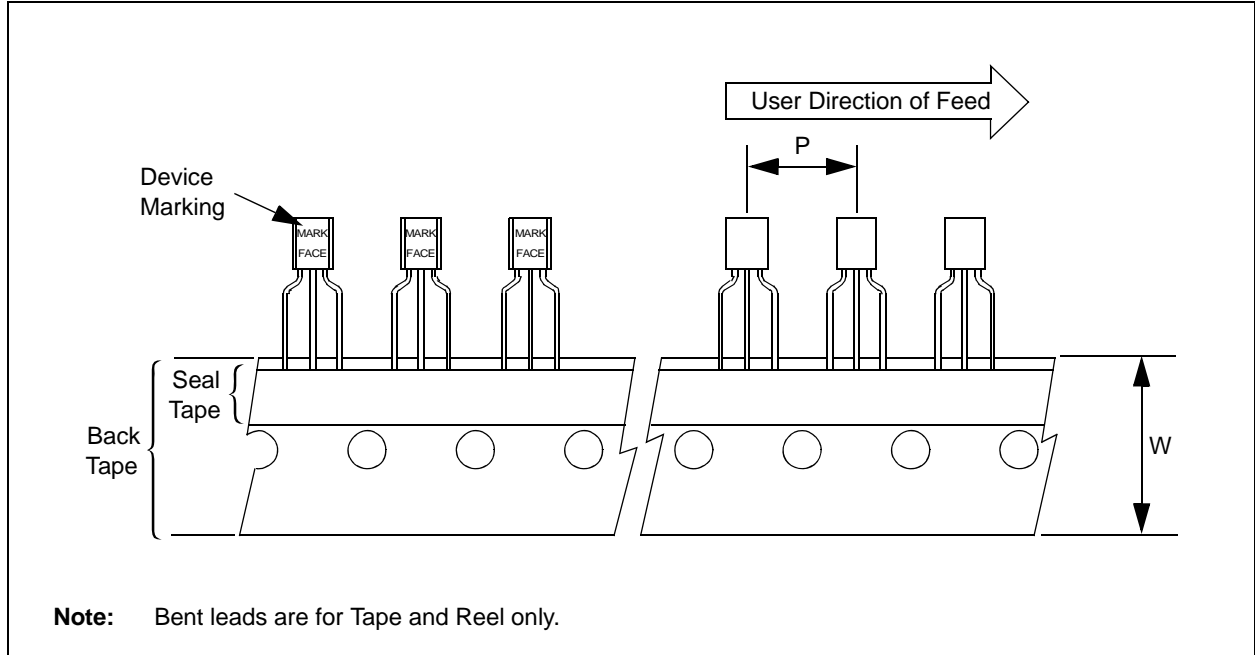

FIGURE 5-3: TO-92 DEVICE TAPE AND REEL SPECIFICATIONS



# MCP102/103/121/131

---

NOTES:

## APPENDIX A: REVISION HISTORY

### Revision B (March 2005)

The following is the list of modifications:

1. Added **Section 4.4 “Using in PICmicro® Microcontroller, ICSP™ Applications (MCP121 only)”** on using the MCP121 in PICmicro microcontroller ICSP applications.
2. Added  $V_{ODH}$  specifications in **Section 1.0 “Electrical Characteristics”** (for ICSP applications).
3. Added Figure 2-33.
4. Updated SC-70 package markings and added Pb-free marking information to **Section 5.0 “Packaging information”**.
5. Added **Appendix A: “Revision History”**.

### Revision A (August 2004)

- Original Release of this Document.

# MCP102/103/121/131

---

NOTES:

## PRODUCT IDENTIFICATION SYSTEM

To order or obtain information, e.g., on pricing or delivery, refer to the factory or the listed sales office.

| <u>PART NO.</u>     | - <u>X</u>          | <u>XXX</u>  | <u>X</u>                                     | / | <u>XX</u>            |
|---------------------|---------------------|---|--|---|----------------------|
| Device              | Tape/Reel<br>Option | Monitoring<br>Options   | Temperature<br>Range                         |   | Package              |
| Device:             |                     |   |  |   |                      |
|                     |                     | MCP102: MicroPower Voltage Supervisor, push-pull  |  |   |                      |
|                     |                     | MCP102T: MicroPower Voltage Supervisor, push-pull<br>(Tape and Reel)  |  |   |                      |
|                     |                     | MCP103: MicroPower Voltage Supervisor, push-pull  |  |   |                      |
|                     |                     | MCP103T: MicroPower Voltage Supervisor, push-pull<br>(Tape and Reel)  |  |   |                      |
|                     |                     | MCP121: MicroPower Voltage Supervisor, open-drain   |  |   |                      |
|                     |                     | MCP121T: MicroPower Voltage Supervisor, open-drain<br>(Tape and Reel)   |  |   |                      |
|                     |                     | MCP131: MicroPower Voltage Supervisor, open-drain   |  |   |                      |
|                     |                     | MCP131T: MicroPower Voltage Supervisor, open-drain<br>(Tape and Reel)   |  |   |                      |
| Monitoring Options: |                     | 195 = 1.90V   |  |   |                      |
|                     |                     | 240 = 2.32V   |  |   |                      |
|                     |                     | 270 = 2.63V   |  |   |                      |
|                     |                     | 300 = 2.93V   |  |   |                      |
|                     |                     | 315 = 3.08V   |  |   |                      |
|                     |                     | 450 = 4.38V   |  |   |                      |
|                     |                     | 475 = 4.63V   |  |   |                      |
| Temperature Range:  |                     |   | I = -40°C to +85°C (MCP11X-195 only)         |   |                      |
|                     |                     |   | E = -40°C to +125°C (Except MCP11X-195 only) |   |                      |
| Package:            |                     |   |  |   | TT = SOT-23B, 3-lead |
|                     |                     |   |  |   | LB = SC-70, 3-lead   |
|                     |                     |   |  |   | TO = TO-92, 3-lead   |
| <b>Examples:</b>    |                     |   |  |   |                      |
| a)                  | MCP102T-195I/TT:    | Tape and Reel,<br>1.95V MicroPower<br>Voltage Supervisor,<br>push-pull, -40°C to +85°C,<br>SOT-23B-3 package.     |  |   |                      |
| b)                  | MCP102-300E/TO:     | 3.00V MicroPower<br>Voltage Supervisor,<br>push-pull,<br>-40°C to +125°C,<br>TO-92-3 package.                     |  |   |                      |
| a)                  | MCP103T-270E/TT:    | Tape and Reel,<br>2.70V MicroPower<br>Voltage Supervisor,<br>push-pull,<br>-40°C to +125°C,<br>SOT-23B-3 package. |  |   |                      |
| b)                  | MCP103T-475E/LB:    | Tape and Reel,<br>4.75V MicroPower<br>Voltage Supervisor,<br>push-pull,<br>-40°C to +125°C,<br>SC-70-3 package.   |  |   |                      |
| a)                  | MCP121T-315I/LB:    | Tape and Reel,<br>3.15V MicroPower<br>Voltage Supervisor,<br>open-drain,<br>-40°C to +125°C,<br>SC-70-3 package.  |  |   |                      |
| b)                  | MCP121-300E/TO:     | 3.00V MicroPower<br>Voltage Supervisor,<br>open-drain,<br>-40°C to +125°C,<br>TO-92-3 package.                    |  |   |                      |
| a)                  | MCP131T-195I/TT:    | Tape and Reel,<br>1.95V MicroPower<br>Voltage Supervisor,<br>open-drain,<br>-40°C to +85°C,<br>SOT-23B-3 package. |  |   |                      |
| b)                  | MCP131-300E/TO:     | 3.00V MicroPower<br>Voltage Supervisor,<br>open-drain,<br>-40°C to +125°C,<br>TO-92-3 package.                    |  |   |                      |

# MCP102/103/121/131

---

NOTES:

---

---

**Note the following details of the code protection feature on Microchip devices:**

- Microchip products meet the specification contained in their particular Microchip Data Sheet.
- Microchip believes that its family of products is one of the most secure families of its kind on the market today, when used in the intended manner and under normal conditions.
- There are dishonest and possibly illegal methods used to breach the code protection feature. All of these methods, to our knowledge, require using the Microchip products in a manner outside the operating specifications contained in Microchip's Data Sheets. Most likely, the person doing so is engaged in theft of intellectual property.
- Microchip is willing to work with the customer who is concerned about the integrity of their code.
- Neither Microchip nor any other semiconductor manufacturer can guarantee the security of their code. Code protection does not mean that we are guaranteeing the product as "unbreakable."

Code protection is constantly evolving. We at Microchip are committed to continuously improving the code protection features of our products. Attempts to break Microchip's code protection feature may be a violation of the Digital Millennium Copyright Act. If such acts allow unauthorized access to your software or other copyrighted work, you may have a right to sue for relief under that Act.

---

Information contained in this publication regarding device applications and the like is provided only for your convenience and may be superseded by updates. It is your responsibility to ensure that your application meets with your specifications. MICROCHIP MAKES NO REPRESENTATIONS OR WARRANTIES OF ANY KIND WHETHER EXPRESS OR IMPLIED, WRITTEN OR ORAL, STATUTORY OR OTHERWISE, RELATED TO THE INFORMATION, INCLUDING BUT NOT LIMITED TO ITS CONDITION, QUALITY, PERFORMANCE, MERCHANTABILITY OR FITNESS FOR PURPOSE. Microchip disclaims all liability arising from this information and its use. Use of Microchip's products as critical components in life support systems is not authorized except with express written approval by Microchip. No licenses are conveyed, implicitly or otherwise, under any Microchip intellectual property rights.

**Trademarks**

The Microchip name and logo, the Microchip logo, Accuron, dsPIC, KEELOQ, microID, MPLAB, PIC, PICmicro, PICSTART, PRO MATE, PowerSmart, rPIC, and SmartShunt are registered trademarks of Microchip Technology Incorporated in the U.S.A. and other countries.

AmpLab, FilterLab, Migratable Memory, MXDEV, MXLAB, PICMASTER, SEEVAL, SmartSensor and The Embedded Control Solutions Company are registered trademarks of Microchip Technology Incorporated in the U.S.A.

Analog-for-the-Digital Age, Application Maestro, dsPICDEM, dsPICDEM.net, dsPICworks, ECAN, ECONOMONITOR, FanSense, FlexROM, fuzzyLAB, In-Circuit Serial Programming, ICSP, ICEPIC, MPASM, MPLIB, MPLINK, MPSIM, PICkit, PICDEM, PICDEM.net, PICLAB, PICtail, PowerCal, PowerInfo, PowerMate, PowerTool, rLAB, rfPICDEM, Select Mode, Smart Serial, SmartTel, Total Endurance and WiperLock are trademarks of Microchip Technology Incorporated in the U.S.A. and other countries.

SQTP is a service mark of Microchip Technology Incorporated in the U.S.A.

All other trademarks mentioned herein are property of their respective companies.

© 2005, Microchip Technology Incorporated, Printed in the U.S.A., All Rights Reserved.

 Printed on recycled paper.

**QUALITY MANAGEMENT SYSTEM**  
**CERTIFIED BY DNV**  
**== ISO/TS 16949:2002 ==**

*Microchip received ISO/TS-16949:2002 quality system certification for its worldwide headquarters, design and wafer fabrication facilities in Chandler and Tempe, Arizona and Mountain View, California in October 2003. The Company's quality system processes and procedures are for its PICmicro® 8-bit MCUs, KEELOQ® code hopping devices, Serial EEPROMs, microperipherals, nonvolatile memory and analog products. In addition, Microchip's quality system for the design and manufacture of development systems is ISO 9001:2000 certified.*



---

---

## WORLDWIDE SALES AND SERVICE

---

---

### AMERICAS

#### Corporate Office

2355 West Chandler Blvd.  
Chandler, AZ 85224-6199  
Tel: 480-792-7200  
Fax: 480-792-7277  
Technical Support:  
<http://support.microchip.com>  
Web Address:  
[www.microchip.com](http://www.microchip.com)

#### Atlanta

Alpharetta, GA  
Tel: 770-640-0034  
Fax: 770-640-0307

#### Boston

Westborough, MA  
Tel: 774-760-0087  
Fax: 774-760-0088

#### Chicago

Itasca, IL  
Tel: 630-285-0071  
Fax: 630-285-0075

#### Dallas

Addison, TX  
Tel: 972-818-7423  
Fax: 972-818-2924

#### Detroit

Farmington Hills, MI  
Tel: 248-538-2250  
Fax: 248-538-2260

#### Kokomo

Kokomo, IN  
Tel: 765-864-8360  
Fax: 765-864-8387

#### Los Angeles

Mission Viejo, CA  
Tel: 949-462-9523  
Fax: 949-462-9608

#### San Jose

Mountain View, CA  
Tel: 650-215-1444  
Fax: 650-961-0286

#### Toronto

Mississauga, Ontario,  
Canada  
Tel: 905-673-0699  
Fax: 905-673-6509

### ASIA/PACIFIC

#### Australia - Sydney

Tel: 61-2-9868-6733  
Fax: 61-2-9868-6755

#### China - Beijing

Tel: 86-10-8528-2100  
Fax: 86-10-8528-2104

#### China - Chengdu

Tel: 86-28-8676-6200  
Fax: 86-28-8676-6599

#### China - Fuzhou

Tel: 86-591-8750-3506  
Fax: 86-591-8750-3521

#### China - Hong Kong SAR

Tel: 852-2401-1200  
Fax: 852-2401-3431

#### China - Shanghai

Tel: 86-21-5407-5533  
Fax: 86-21-5407-5066

#### China - Shenyang

Tel: 86-24-2334-2829  
Fax: 86-24-2334-2393

#### China - Shenzhen

Tel: 86-755-8203-2660  
Fax: 86-755-8203-1760

#### China - Shunde

Tel: 86-757-2839-5507  
Fax: 86-757-2839-5571

#### China - Qingdao

Tel: 86-532-502-7355  
Fax: 86-532-502-7205

### ASIA/PACIFIC

#### India - Bangalore

Tel: 91-80-2229-0061  
Fax: 91-80-2229-0062

#### India - New Delhi

Tel: 91-11-5160-8631  
Fax: 91-11-5160-8632

#### Japan - Kanagawa

Tel: 81-45-471-6166  
Fax: 81-45-471-6122

#### Korea - Seoul

Tel: 82-2-554-7200  
Fax: 82-2-558-5932 or  
82-2-558-5934

#### Singapore

Tel: 65-6334-8870  
Fax: 65-6334-8850

#### Taiwan - Kaohsiung

Tel: 886-7-536-4818  
Fax: 886-7-536-4803

#### Taiwan - Taipei

Tel: 886-2-2500-6610  
Fax: 886-2-2508-0102

#### Taiwan - Hsinchu

Tel: 886-3-572-9526  
Fax: 886-3-572-6459

### EUROPE

#### Austria - Weis

Tel: 43-7242-2244-399  
Fax: 43-7242-2244-393

#### Denmark - Ballerup

Tel: 45-4450-2828  
Fax: 45-4485-2829

#### France - Massy

Tel: 33-1-69-53-63-20  
Fax: 33-1-69-30-90-79

#### Germany - Ismaning

Tel: 49-89-627-144-0  
Fax: 49-89-627-144-44

#### Italy - Milan

Tel: 39-0331-742611  
Fax: 39-0331-466781

#### Netherlands - Drunen

Tel: 31-416-690399  
Fax: 31-416-690340

#### England - Berkshire

Tel: 44-118-921-5869  
Fax: 44-118-921-5820