



Obsolete Device

37LV36/65/128

36K, 64K, and 128K Serial EPROM Family

FEATURES

- Operationally equivalent to Xilinx® XC1700 family
- Wide voltage range 3.0 V to 6.0 V
- Maximum read current 10 mA at 5.0 V
- Standby current 100 μ A typical
- Industry standard Synchronous Serial Interface/ 1 bit per rising edge of clock
- Full Static Operation
- Sequential Read/Program
- Cascadable Output Enable
- 10 MHz Maximum Clock Rate @ 5.0 Vdc
- Programmable Polarity on Hardware Reset
- Programming with industry standard EPROM programmers
- Electrostatic discharge protection > 4,000 volts
- 8-pin PDIP/SOIC and 20-pin PLCC packages
- Data Retention > 200 years
- Temperature ranges:
 - Commercial: 0°C to +70°C
 - Industrial: -40°C to +85°C

DESCRIPTION

The Microchip Technology Inc. 37LV36/65/128 is a family of Serial OTP EPROM devices organized internally in a x32 configuration. The family also features a cascadable option for increased memory storage where needed. The 37LV36/65/128 is suitable for many applications in which look-up table information storage is desirable and provides full static operation in the 3.0V to 6.0V VCC range. The devices also support the industry standard serial interface to the popular RAM-based Field Programmable Gate Arrays (FPGA). Advanced CMOS technology makes this an ideal bootstrap solution for today's high speed SRAM-based FPGAs. The 37LV36/65/128 family is available in the standard 8-pin plastic DIP, 8-pin SOIC and 20-pin PLCC packages.

Device	Bits	Programming Word
37LV36	36,288	1134 x 32
37LV65	65,536	2048 x 32
37LV128	131,072	4096 x 32

PACKAGE TYPES

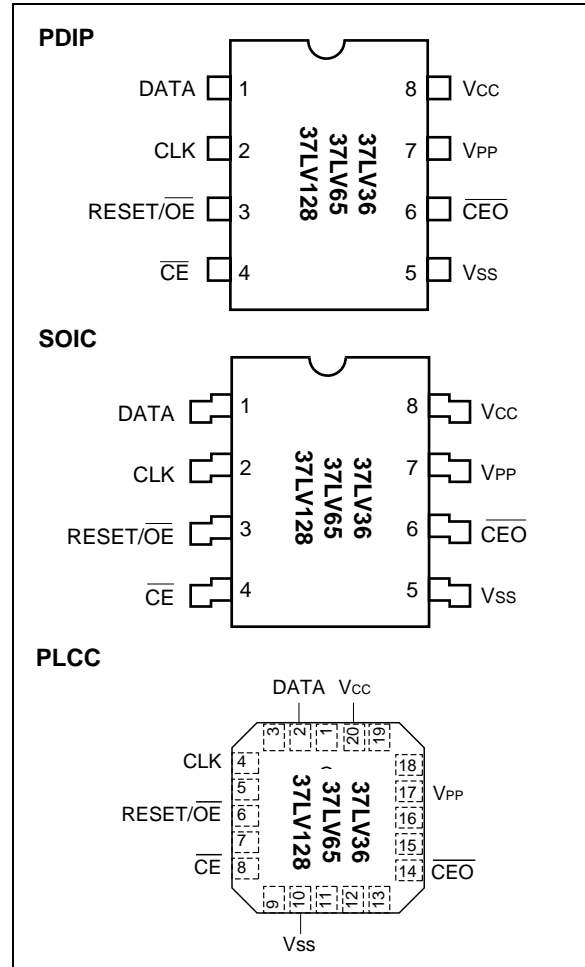

BLOCK DIAGRAM

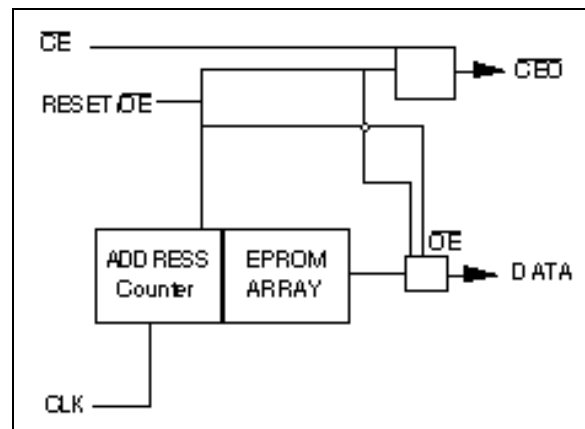

Xilinx is a registered trademark of Xilinx Corporation.

37LV36/65/128

1.0 ELECTRICAL CHARACTERISTICS

1.1 Maximum Ratings*

VCC and input voltages w.r.t. VSS -0.6V to +0.6V
 VPP voltage w.r.t. VSS during programming -0.6V to +14.0V
 Output voltage w.r.t. VSS -0.6V to VCC +0.6V
 Storage temperature -65°C to +150°C
 Ambient temp. with power applied -65°C to +125°C
 Soldering temperature of leads (10 sec.) +300°C
 ESD protection on all pins ≥ 4 kV

*Notice: Stresses above those listed under "Maximum Ratings" may cause permanent damage to the device. This is a stress rating only and functional operation of the device at those or any other conditions above those indicated in the operation listings of this specification is not implied. Exposure to maximum rating conditions for extended periods may affect device reliability.

TABLE 1-1: PIN FUNCTION TABLE

Name	Function	8	20
DATA	Data I/O	1	2
CLK	Clock Input	2	4
RESET/OE	Reset Input and Output Enable	3	6
\overline{CE}	Chip Enable Input	4	8
VSS	Ground	5	10
\overline{CEO}	Chip Enable Output	6	14
VPP	Programming Voltage Supply	7	17
VCC	+3.0V to 6.0V Power Supply	8	20
Not Labeled	Not utilized, not connected		

TABLE 1-2: READ OPERATION DC CHARACTERISTICS

VCC = +3.0 to 6.0V Commercial (C): Tamb = 0°C to +70°C Industrial (I): Tamb = -40°C to +85°C					
Parameter	Symbol	Min.	Max.	Units	Conditions
DATA, \overline{CE} , \overline{CEO} and Reset pins:					
High level input voltage	V _{IH}	2.0	V _{CC}	V	
Low level input voltage	V _{IL}	-0.3	0.8	V	
High level output voltage	V _{OH1}	3.86		V	I _{OH} = -4 mA V _{CC} ≥ 4.5V
	V _{OH2}	2.4		V	I _{OH} = -4 mA V _{CC} ≥ 3.0V
Low level output voltage	V _{OL}	—	.32	V	I _{OL} = 4.0 mA
Input Leakage	I _{LI}	-10	10	μA	V _{IN} = .1V to V _{CC}
Output Leakage	I _{LO}	-10	10	μA	V _{OUT} = .1V to V _{CC}
Input Capacitance (all inputs/outputs)	C _{INT}	—	10	pF	Tamb = 25°C; F _{CLK} = 1 MHz (Note 1)
Operating Current	I _{CC} Read	—	10	mA	V _{CC} = 6.0V, CLK = 10 MHz
		—	2	mA	V _{CC} = 3.6V, CLK = 2.5 MHz Outputs open
Standby Current	I _{CCS}	—	100	μA	V _{CC} = 6.0V, CE = 5.8V
			50	μA	V _{CC} = 3.6V, CE = 3.4V

Note 1: This parameter is initially characterized and not 100% tested.

2.0 DATA

2.1 Data I/O

Three-state DATA output for reading and input during programming.

3.0 CLK

3.1 Clock Input

Used to increment the internal address and bit counters for reading and programming.

4.0 RESET/OE

4.1 Reset Input and Output Enable

A LOW level on both the \overline{CE} and RESET/OE inputs enables the data output driver. A HIGH level on RESET/OE resets both the address and bit counters. In the 37LVXXX, the logic polarity of this input is programmable as either RESET/OE or OE/RESET. This document describes the pin as RESET/OE although the opposite polarity is also possible. This option is defined and set at device program time.

5.0 \overline{CE}

5.1 Chip Enable Input

\overline{CE} is used for device selection. A LOW level on both \overline{CE} and \overline{OE} enables the data output driver. A HIGH level on \overline{CE} disables both the address and bit counters and forces the device into a low power mode.

6.0 CEO

6.1 Chip Enable Output

This signal is asserted LOW on the clock cycle following the last bit read from the memory. It will stay LOW as long as \overline{CE} and \overline{OE} are both LOW. It will then follow \overline{CE} until \overline{OE} goes HIGH. Thereafter, CEO will stay HIGH until the entire EPROM is read again. This pin also used to sense the status of RESET polarity when Programming Mode is entered.

7.0 VPP

7.1 Programming Voltage Supply

Used to enter programming mode (+13 volts) and to program the memory (+13 volts). Must be connected directly to Vcc for normal Read operation. No overshoot above +14 volts is permitted.

8.0 CASCADING SERIAL EPROMS

Cascading Serial EPROMs provide additional memory for multiple FPGAs configured as a daisy-chain, or for future applications requiring larger configuration memories.

When the last bit from the first Serial EPROM is read, the next clock signal to the Serial EPROM asserts its CEO output LOW and disables its DATA line. The second Serial EPROM recognizes the LOW level on its \overline{CE} input and enables its DATA output.

When configuration is complete, the address counters of all cascaded Serial EPROMs are reset if RESET goes LOW forcing the RESET/OE on each Serial EPROM to go HIGH. If the address counters are not to be reset upon completion, then the RESET/OE inputs can be tied to ground.

Additional logic may be required if cascaded memories are so large that the rippled chip enable is not fast enough to activate successive Serial EPROMs.

9.0 STANDBY MODE

The 37LVXXX enters a low-power Standby Mode whenever \overline{CE} is HIGH. In Standby Mode, the Serial EPROM consumes less than 100 μ A of current. The output will remain in a high-impedance state regardless of the state of the \overline{OE} input.

10.0 PROGRAMMING MODE

Programming Mode is entered by holding VPP HIGH (+13 volts) for two clock edges and then holding VPP = VDD for one clock edge. Programming mode is exited by driving a LOW on both \overline{CE} and \overline{OE} and then removing power from the device. Figures 4 through 7 show the programming algorithm.

11.0 37LVXXX RESET POLARITY

The 37LVXXX lets the user choose the reset polarity as either RESET/OE or OE/RESET. Any third-party commercial programmer should prompt the user for the desired reset polarity.

The programming of the overflow word should be handled transparently by the EPROM programmer; it is mentioned here as supplemental information only.

The polarity is programmed into the first overflow word location, maximum address+1. 00000000 in these locations makes the reset active LOW, FFFFFFFF in these locations makes the reset active HIGH. The default condition is RESET active HIGH.

37LV36/65/128

FIGURE 11-1: READ CHARACTERISTICS TIMING

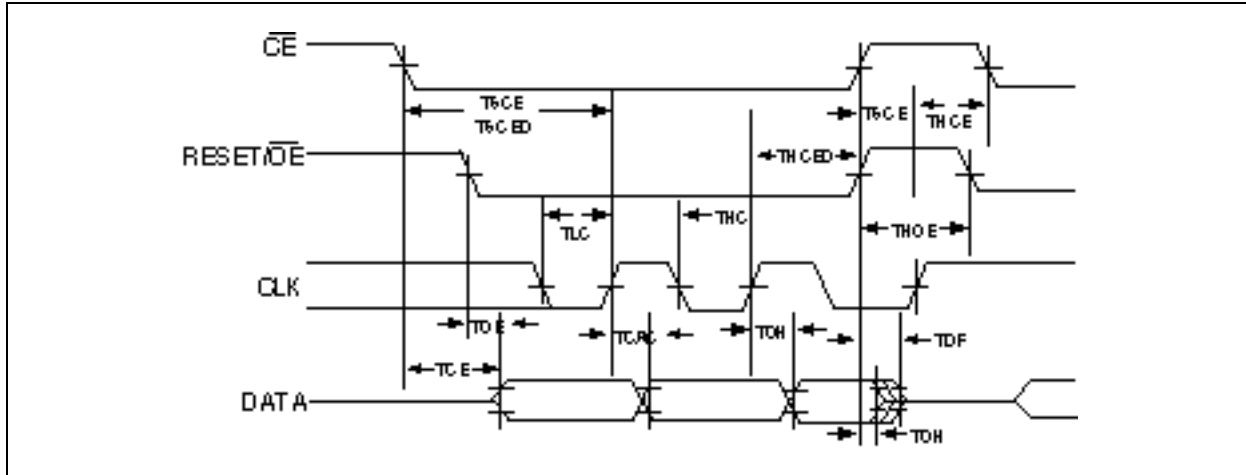

TABLE 11-1: READ CHARACTERISTICS

AC Testing Waveform: $V_{IL} = 0.2V$; $V_{IH} = 3.0V$ AC Test Load: 50 pF $V_{OL} = V_{OL_MAX}$; $V_{OH} = V_{OH_MIN}$							
Symbol	Parameter	Limits $3.0V \leq V_{CC} \leq 6.0V$		Limits $4.5V \leq V_{CC} \leq 6.0V$		Units	Conditions
		Min.	Max.	Min.	Max.		
T_{OE}	\overline{OE} to Data Delay	—	45	—	45	ns	
T_{CE}	\overline{CE} to Data Delay	—	60	—	50	ns	
T_{CAC}	CLK to Data Delay	—	200	—	60	ns	
T_{OH}	Data Hold from \overline{CE} , \overline{OE} or CLK	0	—	0	—	ns	
T_{DF}	\overline{CE} or \overline{OE} to Data Float Delay	—	50	—	50	ns	Notes 1, 2
T_{LC}	CLK Low Time	100	—	25	—	ns	
T_{HC}	CLK High Time	100	—	25	—	ns	
T_{SCE}	\overline{CE} Set up Time to CLK (to guarantee proper counting)	40	—	25	—	ns	Note 1
T_{SCED}	\overline{CE} setup time to CLK (to guarantee proper DATA read)	100	—	80	—	ns	
T_{HCE}	\overline{CE} Hold Time to CLK (to guarantee proper counting)	0	—	0	—	ns	Note 1
T_{HCED}	\overline{CE} hold time to CLK (to guarantee proper DATA read)	50	—	0	—	ns	
T_{HOE}	\overline{OE} High Time (Guarantees counters are Reset)	100	—	20	—	ns	
CLK max	Clock Frequency	—	2.5	—	10	MHz	

Note 1: This parameter is periodically sampled and not 100% tested.

2: Float delays are measured with output pulled through $1k\Omega$ to $V_{LOAD} = V_{CC}/2$.

FIGURE 11-2: READ CHARACTERISTICS AT END OF ARRAY TIMING

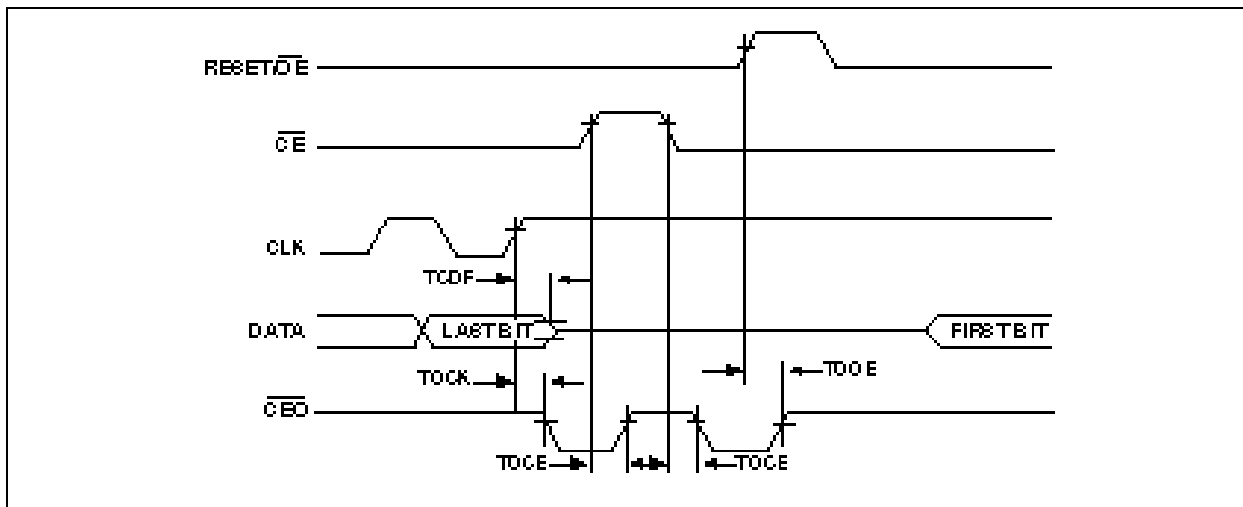

TABLE 11-2: READ CHARACTERISTICS AT END OF ARRAY

AC Testing Waveform: $V_{IL} = 0.2V$; $V_{IH} = 3.0V$ AC Test Load: 50 pF $V_{OL} = V_{OL_MAX}$; $V_{OH} = V_{OH_MIN}$							
Symbol	Parameter	Limits $3.0V \leq V_{CC} \leq 6.0V$		Limits $4.5V \leq V_{CC} \leq 6.0V$		Units	Conditions
		Min.	Max.	Min.	Max.		
Tcdf	CLK to Data Float Delay	—	50	—	50	ns	Notes 1, 2
Tock	CLK to \overline{CEO} Delay	—	65	—	40	ns	
Toce	\overline{CE} to \overline{CEO} Delay	—	45	—	40	ns	
Tooe	RESET/ \overline{OE} to \overline{CEO} Delay	—	45	—	40	ns	

Note 1: This parameter is periodically sampled and not 100% tested.

Note 2: Float delays are measured with output pulled through $1k\Omega$ to $V_{LOAD} = V_{CC}/2$.

TABLE 11-3: PIN ASSIGNMENTS IN THE PROGRAMMING MODE

DIP/SOIC Pin	PLCC Pin	Name	I/O	Description
1	2	DATA	I/O	The rising edge of the clock shifts a data word in or out of the EPROM one bit at a time.
2	4	CLK	I	Clock Input. Used to increment the internal address/word counter for reading and programming operation.
3	6	RESET/ \overline{OE}	I	The rising edge of CLK shifts a data word into the EPROM when \overline{CE} and \overline{OE} are HIGH; it shifts a data word out of the EPROM when \overline{CE} is LOW and \overline{OE} is HIGH. The address/word counter is incremented on the rising edge of CLK while \overline{CE} is held HIGH and \overline{OE} is held LOW. Note 1: Any modified polarity of the RESET/ \overline{OE} pin is ignored in the programming mode.
4	8	\overline{CE}	I	The rising edge of CLK shifts a data word into the EPROM when \overline{CE} and \overline{OE} are HIGH; it shifts a data word out of the EPROM when \overline{CE} is LOW and \overline{OE} is HIGH. The address/word counter is incremented on the rising edge of CLK while \overline{CE} is held HIGH and \overline{OE} is held LOW.
5	10	Vss		Ground pin.
6	14	\overline{CEO}	O	The polarity of the RESET/ \overline{OE} pin can be read by sensing the \overline{CEO} pin. Note 1: The polarity of the RESET/ \overline{OE} pin is ignored while in the Programming Mode. In final verification, this pin must be monitored to go LOW one clock cycle after the last data bit has been read.
7	17	VPP		Programming Voltage Supply. Programming Mode is entered by holding \overline{CE} and \overline{OE} HIGH and VPP at VPP1 for two rising clock edges and then lowering VPP to VPP2 for one more rising clock edge. A word is programmed by strobing the device with VPP for the duration TPGM. VPP must be tied to VCC for normal read operation.
8	20	VCC		+5 V power supply input.

TABLE 11-4: DC PROGRAMMING SPECIFICATIONS

Symbol	Parameter	Limits		Units
		Min.	Max.	
VCCP	Supply voltage during programming	5.0	6.0	V
VIL	Low-level input voltage	0.0	0.5	V
VIH	High-level input voltage	2.4	VCC	V
VOL	Low-level output voltage	—	0.4	V
VOH	High-level output voltage	3.7	—	V
VPP1	Programming voltage*	12.5	13.5	V
VPP2	Programming Mode access voltage	VCCP	VCCP+1	V
IPPP	Supply current in Programming Mode	—	100	mA
IL	Input or output leakage current	-10	10	μA
VCCL	First pass Low-level supply voltage for final verification	2.8	3.0	V
VCCH	Second pass High-level supply voltage for final verification	6.4	6.6	V

* No overshoot is permitted on this signal. VPP must not be allowed to exceed 14 volts.

TABLE 11-5: AC PROGRAMMING SPECIFICATIONS (SEE NOTE 2)

Symbol	Parameter	Limits		Units	Conditions
		Min.	Max.		
TRPP	10% to 90% Rise Time of VPP	1		μs	Note 1
TFPP	90% to 10% Fall Time of VPP	1		μs	Note 1
TPGM	VPP Programming Pulse Width	.50	1.05	ms	
TSVC	VPP Setup to CLK for Entering Programming Mode	100		ns	Note 1
TSVCE	\overline{CE} Setup to CLK for Entering Programming Mode	100		ns	Note 1
TSVOE	\overline{OE} Setup to CLK for Entering Programming Mode	100		ns	Note 1
THVC	VPP Hold from CLK for Entering Programming Mode	300		ns	Note 1
TSDP	Data Setup to CLK for Programming	50		ns	
THDP	Data Hold from CLK for Programming	0		ns	
TLCE	\overline{CE} Low time to clear data latches	100		ns	
TSCC	\overline{CE} Setup to CLK for Programming/Verifying	100		ns	
TSIC	\overline{OE} Setup to CLK for Incrementing Address Counter	100		ns	
THIC	\overline{OE} Hold from CLK for Incrementing Address Counter	0		ns	
THOV	\overline{OE} Hold from VPP	200		ns	Note 1
TPCAC	CLK to Data Valid		400	ns	
TPOH	Data Hold from CLK	0		ns	
TPCE	\overline{CE} Low to Data Valid		250	ns	

Note 1: This parameter is periodically sampled and not 100% tested.

Note 2: While in Programming Mode, \overline{CE} should only be changed while \overline{OE} is HIGH and has been HIGH for 200 ns, and \overline{OE} should only be changed while \overline{CE} is HIGH and has been HIGH for 200 ns.

FIGURE 11-3: ENTER AND EXIT PROGRAMMING MODES

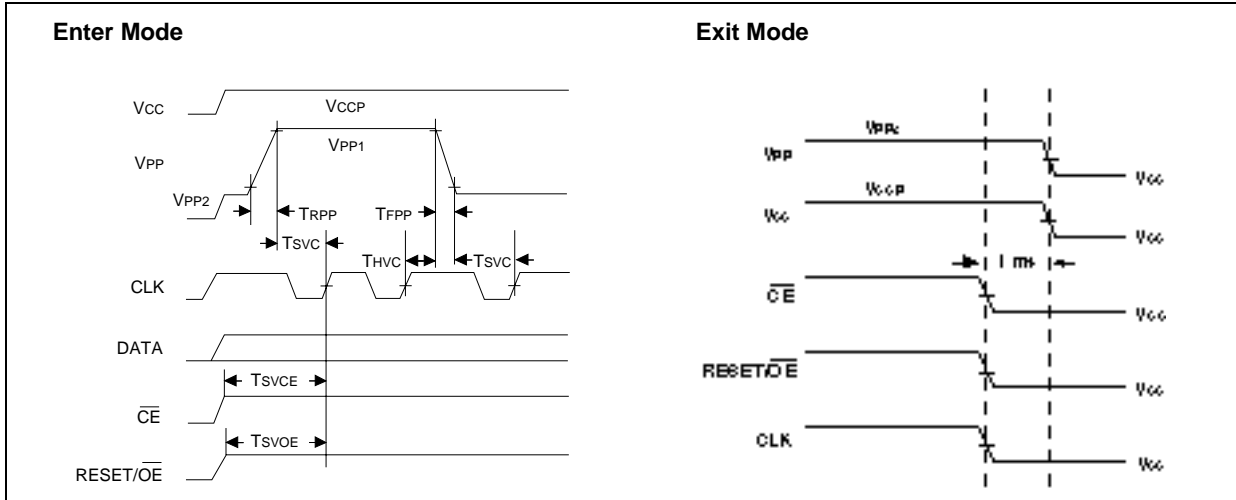

FIGURE 11-4: PROGRAMMING CYCLE OVERVIEW (NO VERIFY UNTIL ENTIRE ARRAY IS PROGRAMMED)

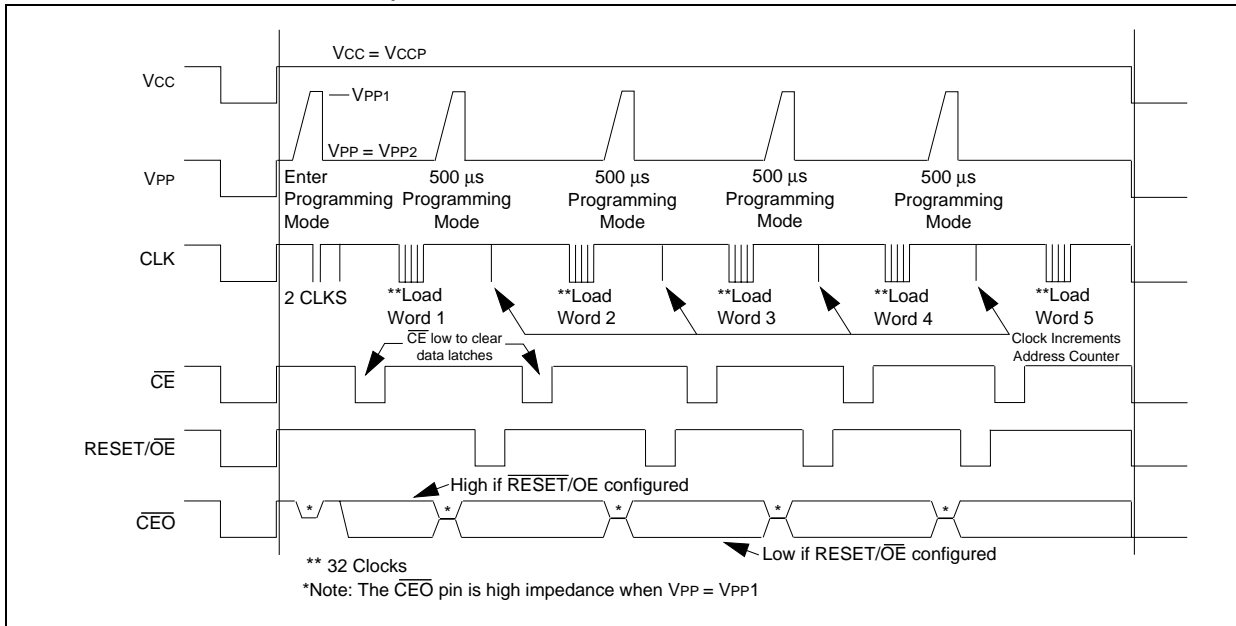

FIGURE 11-5: DETAILS OF PROGRAM CYCLE

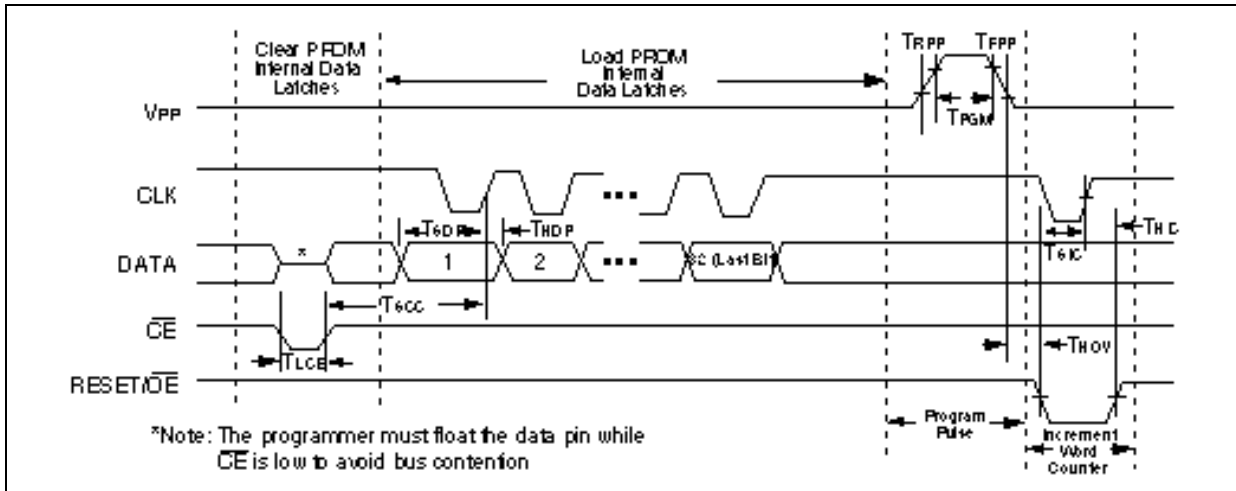

FIGURE 11-6: READ MANUFACTURER AND DEVICE ID OVERVIEW

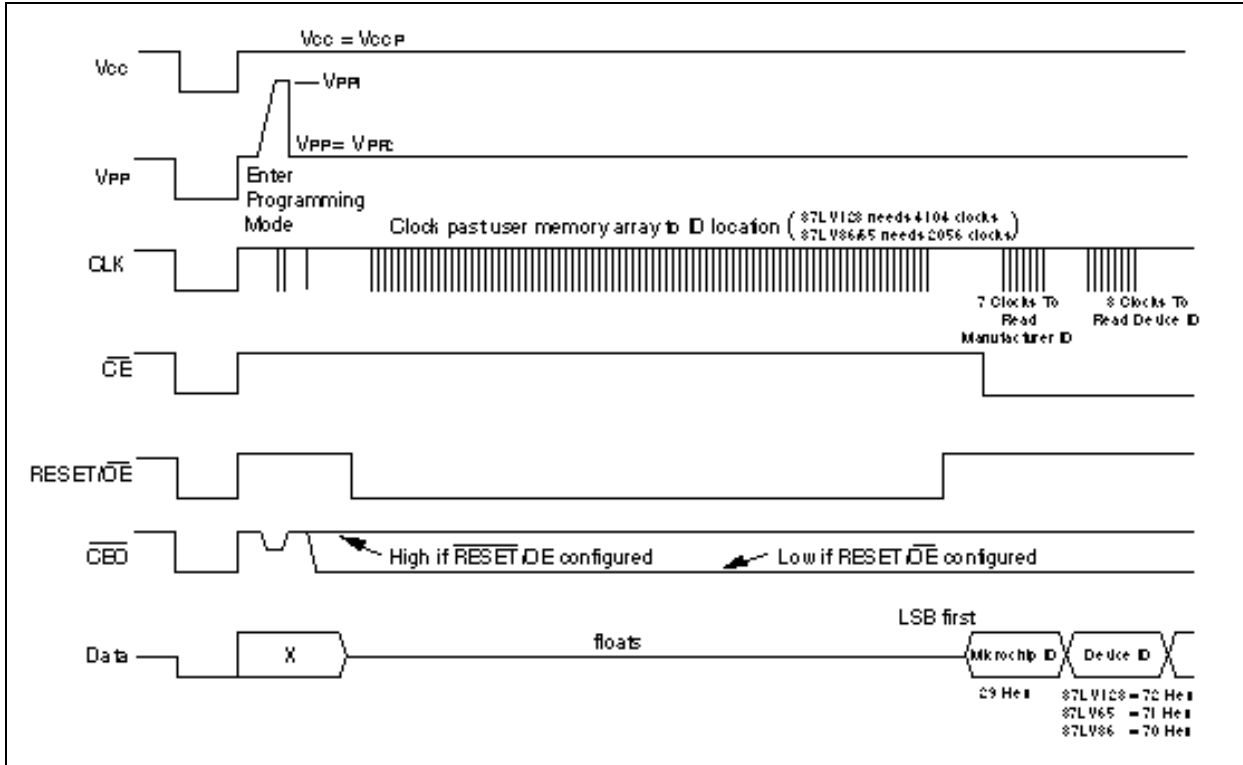

FIGURE 11-7: DETAILS OF READ MANUFACTURER AND DEVICE ID

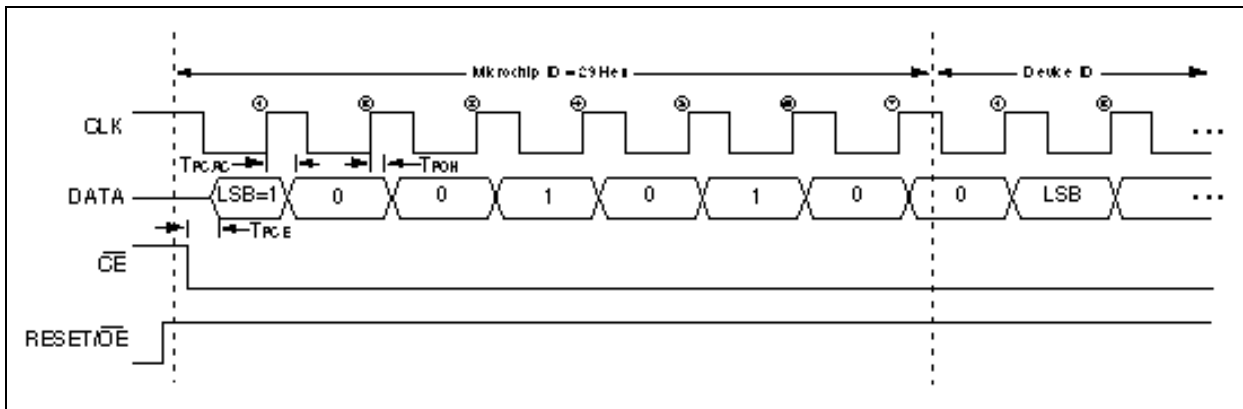
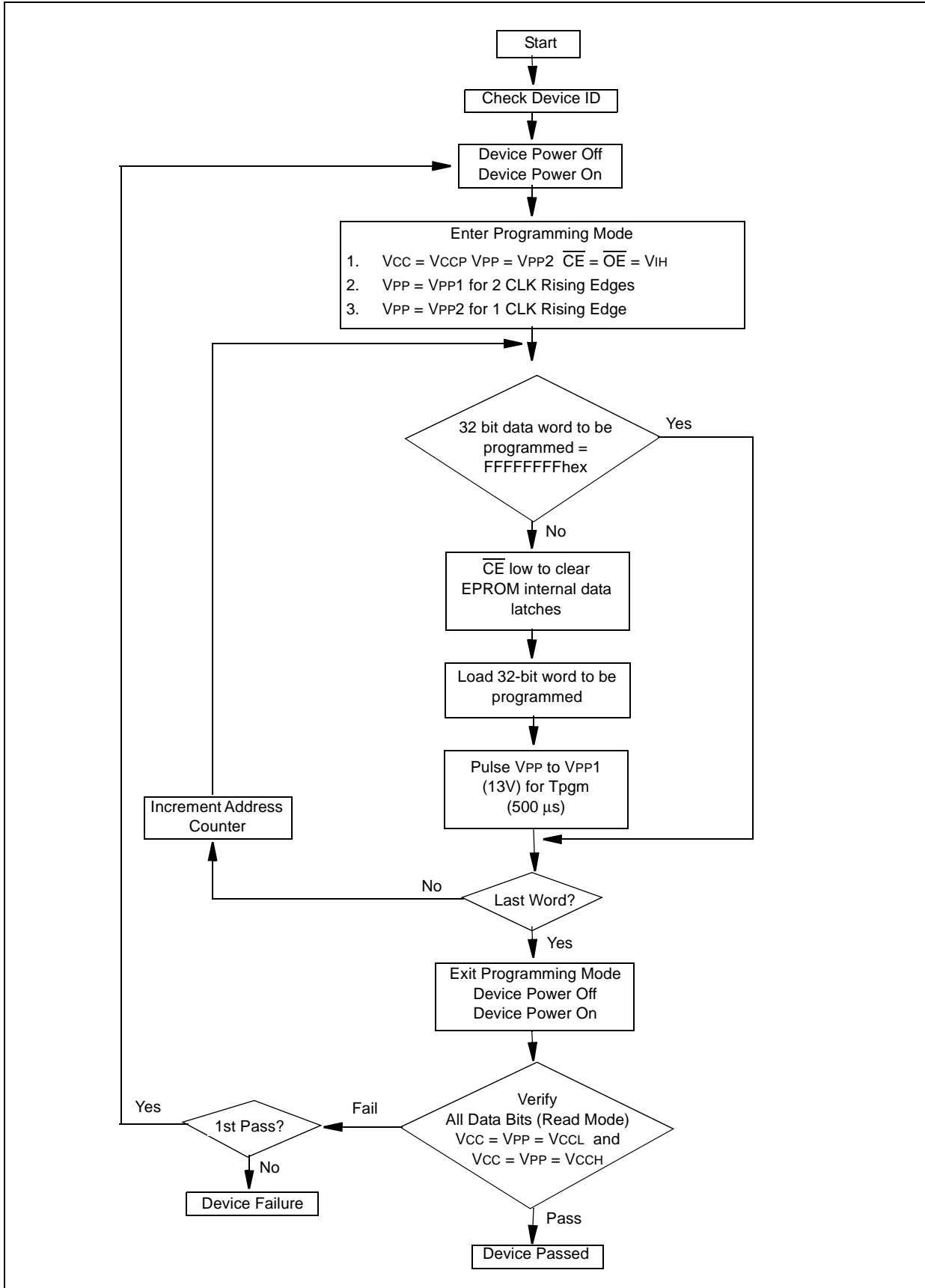

FIGURE 11-8: 37LVXXX PROGRAMMING SPECIFICATIONS



37LV36/65/128 Product Identification System

To order or to obtain information, e.g., on pricing or delivery, please use the listed part numbers, and refer to the factory or the listed sales offices.

37LV36/65/128	-	I	T	/P	
					Package:
					P = Plastic DIP, 8 lead SN = Plastic SOIC (150 mil Body), 8 lead L = Plastic Leaded Chip Carrier (PLCC), 20 lead
					Temperature Range:
					Blank = 0°C to +70°C I = -40°C to +85°C
					Shipping:
					Blank = Tube T = Tape and Reel
					Device:
					37LV128 128K Serial EPROM 37LV65 64K Serial EPROM 37LV36 36K Serial EPROM

NOTES:

Note the following details of the code protection feature on Microchip devices:

- Microchip products meet the specification contained in their particular Microchip Data Sheet.
- Microchip believes that its family of products is one of the most secure families of its kind on the market today, when used in the intended manner and under normal conditions.
- There are dishonest and possibly illegal methods used to breach the code protection feature. All of these methods, to our knowledge, require using the Microchip products in a manner outside the operating specifications contained in Microchip's Data Sheets. Most likely, the person doing so is engaged in theft of intellectual property.
- Microchip is willing to work with the customer who is concerned about the integrity of their code.
- Neither Microchip nor any other semiconductor manufacturer can guarantee the security of their code. Code protection does not mean that we are guaranteeing the product as "unbreakable."

Code protection is constantly evolving. We at Microchip are committed to continuously improving the code protection features of our products. Attempts to break Microchip's code protection feature may be a violation of the Digital Millennium Copyright Act. If such acts allow unauthorized access to your software or other copyrighted work, you may have a right to sue for relief under that Act.

Information contained in this publication regarding device applications and the like is intended through suggestion only and may be superseded by updates. It is your responsibility to ensure that your application meets with your specifications. No representation or warranty is given and no liability is assumed by Microchip Technology Incorporated with respect to the accuracy or use of such information, or infringement of patents or other intellectual property rights arising from such use or otherwise. Use of Microchip's products as critical components in life support systems is not authorized except with express written approval by Microchip. No licenses are conveyed, implicitly or otherwise, under any intellectual property rights.

Trademarks

The Microchip name and logo, the Microchip logo, Accuron, dsPIC, KEELOQ, microID, MPLAB, PIC, PICmicro, PICSTART, PRO MATE, PowerSmart, rPIC, and SmartShunt are registered trademarks of Microchip Technology Incorporated in the U.S.A. and other countries.

AmpLab, FilterLab, MXDEV, MXLAB, PICMASTER, SEEVAL, SmartSensor and The Embedded Control Solutions Company are registered trademarks of Microchip Technology Incorporated in the U.S.A.

Analog-for-the-Digital Age, Application Maestro, dsPICDEM, dsPICDEM.net, dsPICworks, ECAN, ECONOMONITOR, FanSense, FlexROM, fuzzyLAB, In-Circuit Serial Programming, ICSP, ICEPIC, Migratable Memory, MPASM, MPLIB, MPLINK, MPSIM, PICkit, PICDEM, PICDEM.net, PICLAB, PICtail, PowerCal, PowerInfo, PowerMate, PowerTool, rLAB, rPICDEM, Select Mode, Smart Serial, SmartTel and Total Endurance are trademarks of Microchip Technology Incorporated in the U.S.A. and other countries.

SQTP is a service mark of Microchip Technology Incorporated in the U.S.A.

All other trademarks mentioned herein are property of their respective companies.

© 2004, Microchip Technology Incorporated, Printed in the U.S.A., All Rights Reserved.

 Printed on recycled paper.

QUALITY MANAGEMENT SYSTEM
CERTIFIED BY DNV
== ISO/TS 16949:2002 ==

Microchip received ISO/TS-16949:2002 quality system certification for its worldwide headquarters, design and wafer fabrication facilities in Chandler and Tempe, Arizona and Mountain View, California in October 2003. The Company's quality system processes and procedures are for its PICmicro® 8-bit MCUs, KEELOQ® code hopping devices, Serial EEPROMs, microperipherals, nonvolatile memory and analog products. In addition, Microchip's quality system for the design and manufacture of development systems is ISO 9001:2000 certified.



WORLDWIDE SALES AND SERVICE

AMERICAS

Corporate Office

2355 West Chandler Blvd.
Chandler, AZ 85224-6199
Tel: 480-792-7200
Fax: 480-792-7277
Technical Support: 480-792-7627
Web Address: www.microchip.com

Atlanta

3780 Mansell Road, Suite 130
Alpharetta, GA 30022
Tel: 770-640-0034
Fax: 770-640-0307

Boston

2 Lan Drive, Suite 120
Westford, MA 01886
Tel: 978-692-3848
Fax: 978-692-3821

Chicago

333 Pierce Road, Suite 180
Itasca, IL 60143
Tel: 630-285-0071
Fax: 630-285-0075

Dallas

16200 Addison Road, Suite 255
Addison Plaza
Addison, TX 75001
Tel: 972-818-7423
Fax: 972-818-2924

Detroit

Tri-Atria Office Building
32255 Northwestern Highway, Suite 190
Farmington Hills, MI 48334
Tel: 248-538-2250
Fax: 248-538-2260

Kokomo

2767 S. Albright Road
Kokomo, IN 46902
Tel: 765-864-8360
Fax: 765-864-8387

Los Angeles

25950 Acero St., Suite 200
Mission Viejo, CA 92691
Tel: 949-462-9523
Fax: 949-462-9608

San Jose

1300 Terra Bella Avenue
Mountain View, CA 94043
Tel: 650-215-1444
Fax: 650-961-0286

Toronto

6285 Northam Drive, Suite 108
Mississauga, Ontario L4V 1X5, Canada
Tel: 905-673-0699
Fax: 905-673-6509

ASIA/PACIFIC

Australia

Microchip Technology Australia Pty Ltd
Unit 32 41 Rawson Street
Epping 2121, NSW
Sydney, Australia
Tel: 61-2-9868-6733
Fax: 61-2-9868-6755

China - Beijing

Unit 706B
Wan Tai Bei Hai Bldg.
No. 6 Chaoyangmen Bei Str.
Beijing, 100027, China
Tel: 86-10-85282100
Fax: 86-10-85282104

China - Chengdu

Rm. 2401-2402, 24th Floor,
Ming Xing Financial Tower
No. 88 TIDU Street
Chengdu 610016, China
Tel: 86-28-86766200
Fax: 86-28-86766599

China - Fuzhou

Unit 28F, World Trade Plaza
No. 71 Wusi Road
Fuzhou 350001, China
Tel: 86-591-7503506
Fax: 86-591-7503521

China - Hong Kong SAR

Unit 901-6, Tower 2, Metroplaza
223 Hing Fong Road
Kwai Fong, N.T., Hong Kong
Tel: 852-2401-1200
Fax: 852-2401-3431

China - Shanghai

Room 701, Bldg. B
Far East International Plaza
No. 317 Xian Xia Road
Shanghai, 200051
Tel: 86-21-6275-5700
Fax: 86-21-6275-5060

China - Shenzhen

Rm. 1812, 18/F, Building A, United Plaza
No. 5022 Binhe Road, Futian District
Shenzhen 518033, China
Tel: 86-755-82901380
Fax: 86-755-8295-1393

China - Shunde

Room 401, Hongjian Building, No. 2
Fengxiangnan Road, Ronggui Town, Shunde
District, Foshan City, Guangdong 528303, China
Tel: 86-757-28395507 Fax: 86-757-28395571

China - Qingdao

Rm. B505A, Fullhope Plaza,
No. 12 Hong Kong Central Rd.
Qingdao 266071, China
Tel: 86-532-5027355 Fax: 86-532-5027205

India

Divyasree Chambers
1 Floor, Wing A (A3/A4)
No. 11, O'Shaughnessy Road
Bangalore, 560 025, India
Tel: 91-80-22290061 Fax: 91-80-22290062

Japan

Yusen Shin Yokohama Building 10F
3-17-2, Shin Yokohama, Kohoku-ku,
Yokohama, Kanagawa, 222-0033, Japan
Tel: 81-45-471-6166 Fax: 81-45-471-6122

Korea

168-1, Youngbo Bldg. 3 Floor
Samsung-Dong, Kangnam-Ku
Seoul, Korea 135-882
Tel: 82-2-554-7200 Fax: 82-2-558-5932 or
82-2-558-5934

Singapore

200 Middle Road
#07-02 Prime Centre
Singapore, 188980
Tel: 65-6334-8870 Fax: 65-6334-8850

Taiwan

Kaohsiung Branch
30F - 1 No. 8
Min Chuan 2nd Road
Kaohsiung 806, Taiwan
Tel: 886-7-536-4816
Fax: 886-7-536-4817

Taiwan

Taiwan Branch
11F-3, No. 207
Tung Hua North Road
Taipei, 105, Taiwan
Tel: 886-2-2717-7175 Fax: 886-2-2545-0139

Taiwan

Taiwan Branch
13F-3, No. 295, Sec. 2, Kung Fu Road
Hsinchu City 300, Taiwan
Tel: 886-3-572-9526
Fax: 886-3-572-6459

EUROPE

Austria

Durisolstrasse 2
A-4600 Wels
Austria
Tel: 43-7242-2244-399
Fax: 43-7242-2244-393

Denmark

Regus Business Centre
Lautrup høj 1-3
Ballerup DK-2750 Denmark
Tel: 45-4420-9895 Fax: 45-4420-9910

France

Parc d'Activite du Moulin de Massy
43 Rue du Saule Trapu
Batiment A - 1er Etage
91300 Massy, France
Tel: 33-1-69-53-63-20
Fax: 33-1-69-30-90-79

Germany

Steinheilstrasse 10
D-85737 Ismaning, Germany
Tel: 49-89-627-144-0
Fax: 49-89-627-144-44

Italy

Via Salvatore Quasimodo, 12
20025 Legnano (MI)
Milan, Italy
Tel: 39-0331-742611
Fax: 39-0331-466781

Netherlands

Waegenburghtplein 4
NL-5152 JR, Drunen, Netherlands
Tel: 31-416-690399
Fax: 31-416-690340

United Kingdom

505 Eskdale Road
Winnersh Triangle
Wokingham
Berkshire, England RG41 5TU
Tel: 44-118-921-5869
Fax: 44-118-921-5820