



**MICROCHIP**

---

**PIC18(L)F1XK22**  
**Data Sheet**

20-Pin Flash Microcontrollers  
with nanoWatt XLP Technology

---

**Note the following details of the code protection feature on Microchip devices:**

- Microchip products meet the specification contained in their particular Microchip Data Sheet.
- Microchip believes that its family of products is one of the most secure families of its kind on the market today, when used in the intended manner and under normal conditions.
- There are dishonest and possibly illegal methods used to breach the code protection feature. All of these methods, to our knowledge, require using the Microchip products in a manner outside the operating specifications contained in Microchip's Data Sheets. Most likely, the person doing so is engaged in theft of intellectual property.
- Microchip is willing to work with the customer who is concerned about the integrity of their code.
- Neither Microchip nor any other semiconductor manufacturer can guarantee the security of their code. Code protection does not mean that we are guaranteeing the product as "unbreakable."

Code protection is constantly evolving. We at Microchip are committed to continuously improving the code protection features of our products. Attempts to break Microchip's code protection feature may be a violation of the Digital Millennium Copyright Act. If such acts allow unauthorized access to your software or other copyrighted work, you may have a right to sue for relief under that Act.

---

Information contained in this publication regarding device applications and the like is provided only for your convenience and may be superseded by updates. It is your responsibility to ensure that your application meets with your specifications. MICROCHIP MAKES NO REPRESENTATIONS OR WARRANTIES OF ANY KIND WHETHER EXPRESS OR IMPLIED, WRITTEN OR ORAL, STATUTORY OR OTHERWISE, RELATED TO THE INFORMATION, INCLUDING BUT NOT LIMITED TO ITS CONDITION, QUALITY, PERFORMANCE, MERCHANTABILITY OR FITNESS FOR PURPOSE. Microchip disclaims all liability arising from this information and its use. Use of Microchip devices in life support and/or safety applications is entirely at the buyer's risk, and the buyer agrees to defend, indemnify and hold harmless Microchip from any and all damages, claims, suits, or expenses resulting from such use. No licenses are conveyed, implicitly or otherwise, under any Microchip intellectual property rights.

**Trademarks**

The Microchip name and logo, the Microchip logo, dsPIC, KEELOQ, KEELOQ logo, MPLAB, PIC, PICmicro, PICSTART, PIC<sup>32</sup> logo, rPIC and UNI/O are registered trademarks of Microchip Technology Incorporated in the U.S.A. and other countries.


FilterLab, Hampshire, HI-TECH C, Linear Active Thermistor, MXDEV, MXLAB, SEEVAL and The Embedded Control Solutions Company are registered trademarks of Microchip Technology Incorporated in the U.S.A.

Analog-for-the-Digital Age, Application Maestro, chipKIT, chipKIT logo, CodeGuard, dsPICDEM, dsPICDEM.net, dsPICworks, dsSPEAK, ECAN, ECONOMONITOR, FanSense, HI-TIDE, In-Circuit Serial Programming, ICSP, Mindi, MiWi, MPASM, MPLAB Certified logo, MPLIB, MPLINK, mTouch, Omniscient Code Generation, PICC, PICC-18, PICDEM, PICDEM.net, PICkit, PICtail, REAL ICE, rLAB, Select Mode, Total Endurance, TSHARC, UniWinDriver, WiperLock and ZENA are trademarks of Microchip Technology Incorporated in the U.S.A. and other countries.

SQTP is a service mark of Microchip Technology Incorporated in the U.S.A.

All other trademarks mentioned herein are property of their respective companies.

© 2009-2011, Microchip Technology Incorporated, Printed in the U.S.A., All Rights Reserved.

 Printed on recycled paper.

ISBN: 978-1-61341-715-7

**QUALITY MANAGEMENT SYSTEM**  
**CERTIFIED BY DNV**  
**== ISO/TS 16949:2009 ==**

*Microchip received ISO/TS-16949:2009 certification for its worldwide headquarters, design and wafer fabrication facilities in Chandler and Tempe, Arizona; Gresham, Oregon and design centers in California and India. The Company's quality system processes and procedures are for its PIC<sup>®</sup> MCUs and dsPIC<sup>®</sup> DSCs, KEELOQ<sup>®</sup> code hopping devices, Serial EEPROMs, microperipherals, nonvolatile memory and analog products. In addition, Microchip's quality system for the design and manufacture of development systems is ISO 9001:2000 certified.*

---

**20-Pin Flash Microcontrollers with nanoWatt XLP Technology**

---

**High-Performance RISC CPU:**

- C Compiler Optimized Architecture:
  - Optional extended instruction set designed to optimize re-entrant code
- 256 bytes Data EEPROM
- Up to 16 Kbytes Linear Program Memory Addressing
- Up to 512 bytes Linear Data Memory Addressing
- Up to 16 MIPS Operation
- 16-bit Wide Instructions, 8-bit Wide Data Path
- Priority Levels for Interrupts
- 31-Level, Software Accessible Hardware Stack
- 8 x 8 Single-Cycle Hardware Multiplier

**Flexible Oscillator Structure:**

- Precision 16 MHz Internal Oscillator Block:
  - Factory calibrated to  $\pm 1\%$
  - Software selectable frequencies range of 31 kHz to 16 MHz
  - 64 MHz performance available using PLL – no external components required
- Four Crystal modes up to 64 MHz
- Two External Clock modes up to 64 MHz
- 4X Phase Lock Loop (PLL)
- Secondary Oscillator using Timer1 @ 32 kHz
- Fail-Safe Clock Monitor
  - Allows for safe shutdown if peripheral clock stops
- Two-Speed Oscillator Start-up

**Special Microcontroller Features:**

- 2.3V - 5.5V Operation – PIC18F1XK22
- 1.8V-3.6V Operation – PIC18LF1XK22
- Self-reprogrammable under Software Control
- Power-on Reset (POR), Power-up Timer (PWRT) and Oscillator Start-up Timer (OST)
- Programmable Brown-out Reset (BOR)
- Extended Watchdog Timer (WDT):
  - Programmable period from 4ms to 131s
- Programmable Code Protection
- In-Circuit Serial Programming™ (ICSP™) via two pins
- In-Circuit Debug via Two Pins

**Extreme Low-Power Management  
PIC18LF1XK22 with nanoWatt XLP:**

- Sleep mode: 34 nA
- Watchdog Timer: 460 nA
- Timer1 Oscillator: 650 nA @ 32 kHz

**Analog Features:**

- Analog-to-Digital Converter (ADC) module
  - 10-bit resolution, 12 channels
  - Auto acquisition capability
  - Conversion available during Sleep
- Analog Comparator module:
  - Two rail-to-rail analog comparators
  - Independent input multiplexing
  - Inputs and outputs externally accessible
- Voltage Reference module:
  - Programmable (% of VDD), 16 steps
  - Two 16-level voltage ranges using VREF pins
  - Programmable Fixed Voltage Reference (FVR), 3 levels

**Peripheral Highlights:**

- 17 I/O Pins and 1 Input-only Pin:
  - High current sink/source 25 mA/25 mA
  - Programmable weak pull-ups
  - Programmable interrupt-on-change
  - Three external interrupt pins
- Four Timer modules:
  - 3 16-bit timers/counters with prescaler
  - 1 8-bit timer/counter with 8-bit period register, prescaler and postscaler
  - Dedicated, low-power Timer1 oscillator
- Enhanced Capture/Compare/PWM (ECCP) module:
  - One, two or four PWM outputs
  - Selectable polarity
  - Programmable dead time
  - Auto-shutdown and Auto-restart
  - PWM output steering control
- Master Synchronous Serial Port (MSSP) module
  - 3-wire SPI (supports all 4 SPI modes)
  - I<sup>2</sup>C™ Master and Slave modes (Slave mode address masking)
- Enhanced Universal Synchronous Asynchronous Receiver Transmitter module (EUSART)
  - Supports RS-232, RS-485 and LIN 2.0
  - Auto-Baud Detect
  - Auto Wake-up on Break
- SR Latch (555 Timer) module with:
  - Configurable inputs and outputs
  - Supports mTouch™ capacitive sensing applications

# PIC18(L)F1XK22

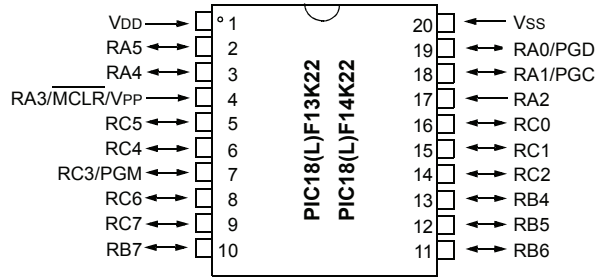
**TABLE 1: DEVICE OVERVIEW**

Device	Program Memory		Data Memory		Pins	I/O <sup>(1)</sup>	10-bit A/D Channels	Comparators	Timers 8-bit/16-bit	ECCP	MSSP	EUSART	SR Latch
	Bytes	Words	SRAM (bytes)	Data EEPROM (bytes)									
PIC18F13K22 PIC18LF13K22	8K	4K	256	256	20	18	12-ch	2	1 / 3	1	1	1	Yes
PIC18F14K22 PIC18LF14K22	16K	8K	512	256	20	18	12-ch	2	1 / 3	1	1	1	Yes

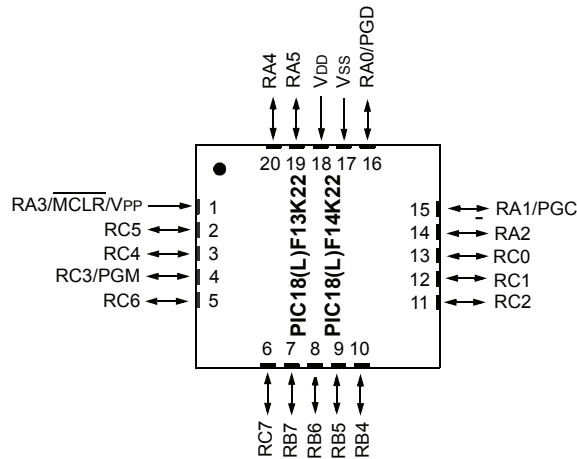
**Note 1:** One pin is input-only.

## Pin Diagrams

### 20-pin PDIP, SSOP, SOIC (300 MIL)



### 20-Pin QFN 4x4



# PIC18(L)F1XK22

**TABLE 2: PIC18(L)F1XK22 PIN SUMMARY**

20-Pin DIL	20-Pin QFN	I/O	Analog	Comparator	Reference	ECCP	EUSART	MSSP	SR Latch	Timers	Interrupts	Pull-up	Basic
19	16	RA0	AN0	C1IN+	VREF-/CVREF	—	—	—	—	—	IOC/INT0	Y	PGD
18	15	RA1	AN1	C12IN0-	VREF+	—	—	—	—	—	IOC/INT1	Y	PGC
17	14	RA2	AN2	C1OUT	—	—	—	—	SRQ	T0CKI	IOC/INT2	Y	—
4	1	RA3	—	—	—	—	—	—	—	—	IOC	Y	MCLR/VPP
3	20	RA4	AN3	—	—	—	—	—	—	—	IOC	Y	OSC2/CLKOUT
2	19	RA5	—	—	—	—	—	—	—	T13CKI	IOC	Y	OSC1/CLKIN
13	10	RB4	AN10	—	—	—	—	SDI/SDA	—	—	IOC	Y	—
12	9	RB5	AN11	—	—	—	RX/DT	—	—	—	IOC	Y	—
11	8	RB6	—	—	—	—	—	SCL/SCK	—	—	IOC	Y	—
10	7	RB7	—	—	—	—	TX/CK	—	—	—	IOC	Y	—
16	13	RC0	AN4	C2IN+	—	—	—	—	—	—	—	—	—
15	12	RC1	AN5	C12IN1-	—	—	—	—	—	—	—	—	—
14	11	RC2	AN6	C12IN2-	—	P1D	—	—	—	—	—	—	—
7	4	RC3	AN7	C12IN3-	—	P1C	—	—	—	—	—	—	PGM
6	3	RC4	—	C2OUT	—	P1B	—	—	SRNQ	—	—	—	—
5	2	RC5	—	—	—	CCP1/P1A	—	—	—	—	—	—	—
8	5	RC6	AN8	—	—	—	—	SS	—	—	—	—	—
9	6	RC7	AN9	—	—	—	—	SDO	—	—	—	—	—
1	18	—	—	—	—	—	—	—	—	—	—	—	VDD
20	17	—	—	—	—	—	—	—	—	—	—	—	VSS

# PIC18(L)F1XK22

## Table of Contents

1.0	Device Overview .....	7
2.0	Oscillator Module.....	13
3.0	Memory Organization .....	25
4.0	Flash Program Memory .....	47
5.0	Data EEPROM Memory .....	57
6.0	8x8 Hardware Multiplier.....	61
7.0	Interrupts .....	63
8.0	I/O Ports .....	77
9.0	Timer0 Module .....	95
10.0	Timer1 Module .....	99
11.0	Timer2 Module .....	105
12.0	Timer3 Module .....	107
13.0	Enhanced Capture/Compare/PWM (ECCP) Module.....	111
14.0	Master Synchronous Serial Port (MSSP) Module .....	133
15.0	Enhanced Universal Synchronous Asynchronous Receiver Transmitter (EUSART) .....	175
16.0	Analog-to-Digital Converter (ADC) Module .....	203
17.0	Comparator Module.....	217
18.0	Power-Managed Modes .....	229
19.0	SR Latch.....	235
20.0	Voltage References.....	239
21.0	Reset.....	245
22.0	Special Features of the CPU.....	257
23.0	Instruction Set Summary .....	273
24.0	Development Support.....	323
25.0	Electrical Specifications.....	327
26.0	DC and AC Characteristics Graphs and Tables.....	363
27.0	Packaging Information.....	379
	Appendix A: Revision History.....	389
	Appendix B: Device Differences.....	389

## TO OUR VALUED CUSTOMERS

It is our intention to provide our valued customers with the best documentation possible to ensure successful use of your Microchip products. To this end, we will continue to improve our publications to better suit your needs. Our publications will be refined and enhanced as new volumes and updates are introduced.

If you have any questions or comments regarding this publication, please contact the Marketing Communications Department via E-mail at [docerrors@microchip.com](mailto:docerrors@microchip.com) or fax the **Reader Response Form** in the back of this data sheet to (480) 792-4150. We welcome your feedback.

### Most Current Data Sheet

To obtain the most up-to-date version of this data sheet, please register at our Worldwide Web site at:

<http://www.microchip.com>

You can determine the version of a data sheet by examining its literature number found on the bottom outside corner of any page. The last character of the literature number is the version number, (e.g., DS30000A is version A of document DS30000).

### Errata

An errata sheet, describing minor operational differences from the data sheet and recommended workarounds, may exist for current devices. As device/documentation issues become known to us, we will publish an errata sheet. The errata will specify the revision of silicon and revision of document to which it applies.

To determine if an errata sheet exists for a particular device, please check with one of the following:

- Microchip's Worldwide Web site; <http://www.microchip.com>
- Your local Microchip sales office (see last page)

When contacting a sales office, please specify which device, revision of silicon and data sheet (include literature number) you are using.

### Customer Notification System

Register on our web site at [www.microchip.com](http://www.microchip.com) to receive the most current information on all of our products.

## 1.0 DEVICE OVERVIEW

This family offers the advantages of all PIC18 microcontrollers – namely, high computational performance with the addition of high-endurance, Flash program memory. On top of these features, the PIC18(L)F1XK22 family introduces design enhancements that make these microcontrollers a logical choice for many high-performance, power sensitive applications.

### 1.1 New Core Features

#### 1.1.1 nanoWatt XLP TECHNOLOGY

All of the devices in the PIC18(L)F1XK22 family incorporate a range of features that can significantly reduce power consumption during operation. Key items include:

- **Multiple Idle Modes:** The controller can also run with its CPU core disabled but the peripherals still active. In these states, power consumption can be reduced even further, to as little as 4% of normal operation requirements.
- **On-the-fly Mode Switching:** The power-managed modes are invoked by user code during operation, allowing the user to incorporate power-saving ideas into their application's software design.
- **Low Consumption in Key Modules:** The power requirements for both Timer1 and the Watchdog Timer are minimized. See [Section 25.0 “Electrical Specifications”](#) for values.

#### 1.1.2 MULTIPLE OSCILLATOR OPTIONS AND FEATURES

All of the devices in the PIC18(L)F1XK22 family offer ten different oscillator options, allowing users a wide range of choices in developing application hardware. These include:

- Four Crystal modes, using crystals or ceramic resonators
- External Clock modes, offering the option of using two pins (oscillator input and a divide-by-4 clock output) or one pin (oscillator input, with the second pin reassigned as general I/O)
- External RC Oscillator modes with the same pin options as the External Clock modes
- An internal oscillator block which contains a 16 MHz HFINTOSC oscillator and a 31 kHz LFINTOSC oscillator which together provide 8 user selectable clock frequencies, from 31 kHz to 16 MHz. This option frees the two oscillator pins for use as additional general purpose I/O.
- A Phase Lock Loop (PLL) frequency multiplier, available to both the high-speed crystal and internal oscillator modes, which allows clock speeds of up to 64 MHz. Used with the internal oscillator, the PLL gives users a complete selection of clock speeds, from 31 kHz to 32 MHz – all without using an external crystal or clock circuit.

Besides its availability as a clock source, the internal oscillator block provides a stable reference source that gives the family additional features for robust operation:

- **Fail-Safe Clock Monitor:** This option constantly monitors the main clock source against a reference signal provided by the LFINTOSC. If a clock failure occurs, the controller is switched to the internal oscillator block, allowing for continued operation or a safe application shutdown.
- **Two-Speed Start-up:** This option allows the internal oscillator to serve as the clock source from Power-on Reset, or wake-up from Sleep mode, until the primary clock source is available.

# PIC18(L)F1XK22

---

## 1.2 Other Special Features

- **Memory Endurance:** The Flash cells for both program memory and data EEPROM are rated to last for many thousands of erase/write cycles – up to 10K for program memory and 100K for EEPROM. Data retention without refresh is conservatively estimated to be greater than 40 years.
- **Self-programmability:** These devices can write to their own program memory spaces under internal software control. Using a bootloader routine located in the code protected Boot Block, it is possible to create an application that can update itself in the field.
- **Extended Instruction Set:** The PIC18(L)F1XK22 family introduces an optional extension to the PIC18 instruction set, which adds 8 new instructions and an Indexed Addressing mode. This extension has been specifically designed to optimize re-entrant application code originally developed in high-level languages, such as C.
- **Enhanced CCP module:** In PWM mode, this module provides 1, 2 or 4 modulated outputs for controlling half-bridge and full-bridge drivers. Other features include:
  - Auto-Shutdown, for disabling PWM outputs on interrupt or other select conditions
  - Auto-Restart, to reactivate outputs once the condition has cleared
  - Output steering to selectively enable one or more of 4 outputs to provide the PWM signal.
- **Enhanced Addressable USART:** This serial communication module is capable of standard RS-232 operation and provides support for the LIN bus protocol. Other enhancements include automatic baud rate detection and a 16-bit Baud Rate Generator for improved resolution.
- **10-bit A/D Converter:** This module incorporates programmable acquisition time, allowing for a channel to be selected and a conversion to be initiated without waiting for a sampling period and thus, reduce code overhead.
- **Extended Watchdog Timer (WDT):** This enhanced version incorporates a 16-bit postscaler, allowing an extended time-out range that is stable across operating voltage and temperature. See [Section 25.0 “Electrical Specifications”](#) for time-out periods.

## 1.3 Details on Individual Family Members

Devices in the PIC18(L)F1XK22 family are available in 20-pin packages. Block diagrams for the two groups are shown in [Figure 1-1](#).

The devices are differentiated from each other in the following ways:

1. Flash program memory:
  - 8 Kbytes for PIC18(L)F13K22
  - 16 Kbytes for PIC18(L)F14K22

All other features for devices in this family are identical. These are summarized in [Table 1-1](#).

The pinouts for all devices are listed in [Table 2](#) and I/O description are in [Table 1-2](#).



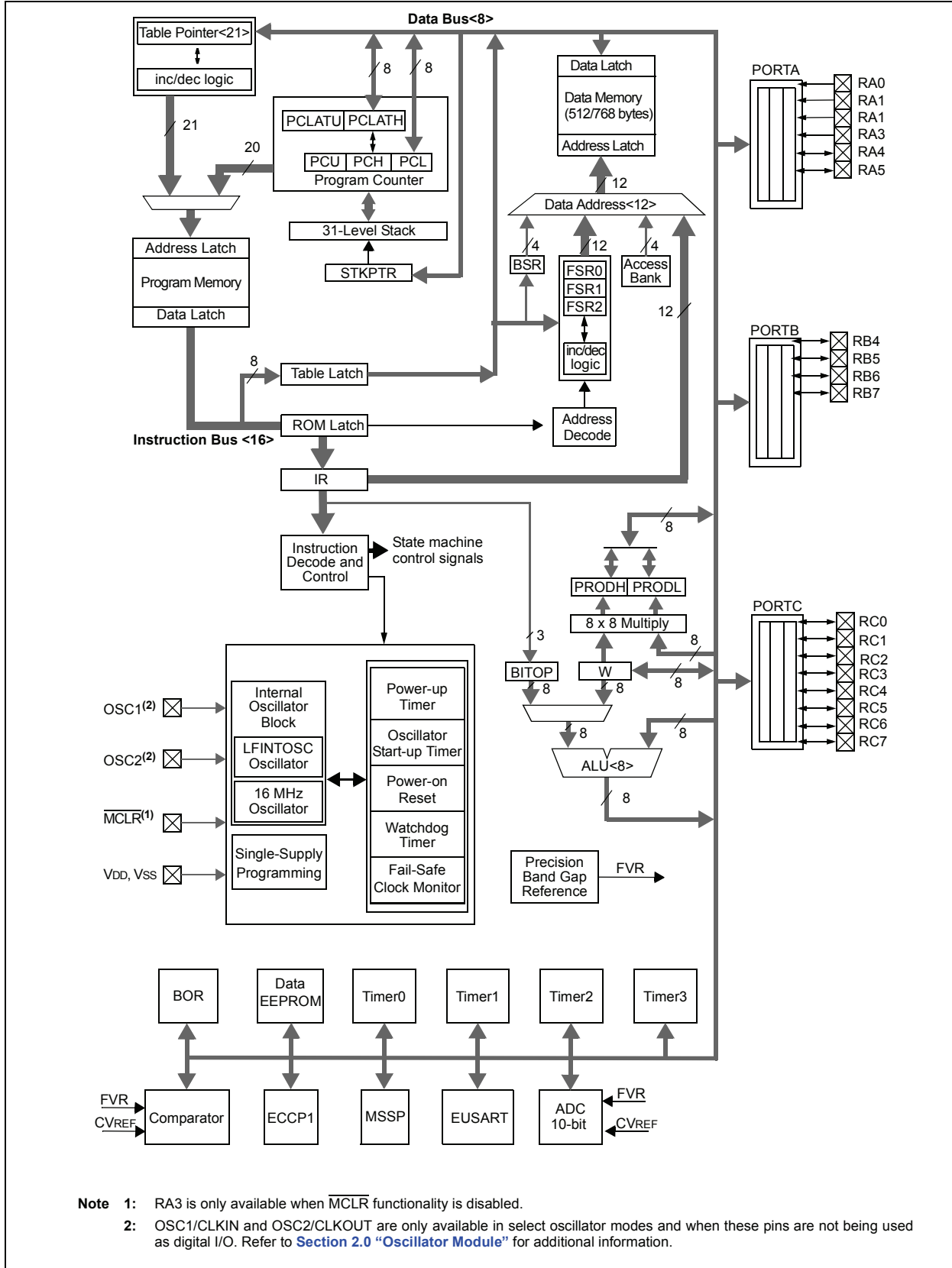
# PIC18(L)F1XK22

**TABLE 1-1: DEVICE FEATURES FOR THE PIC18(L)F1XK22 (20-PIN DEVICES)**

Features	PIC18F13K22	PIC18LF13K22	PIC18F14K22	PIC18LF14K22
Voltage Range (1.8 - 5.5V)	2.3-5.5V	1.8V-3.6V	2.3-5.5V	1.8V-3.6V
Program Memory (Bytes)	8K		16K	
Program Memory (Instructions)	4096		8192	
Data Memory (Bytes)	256		512	
Operating Frequency	DC – 64 MHz			
Interrupt Sources	30			
I/O Ports	Ports A, B, C			
Timers	4			
Enhanced Capture/ Compare/PWM Modules	1			
Serial Communications	MSSP, Enhanced USART			
10-Bit Analog-to-Digital Module	12 Input Channels			
Resets (and Delays)	POR, BOR, RESET Instruction, Stack Full, Stack Underflow, MCLR, WDT (PWRT, OST)			
Instruction Set	75 Instructions, 83 with Extended Instruction Set Enabled			
Packages	20-Pin PDIP, SSOP, SOIC (300 mil) QFN (4x4x0.9mm)			

# PIC18(L)F1XK22

FIGURE 1-1: PIC18(L)F1XK22 BLOCK DIAGRAM



# PIC18(L)F1XK22

**TABLE 1-2: PIC18(L)F1XK22 PIN SUMMARY**

Pin Name	Pin Number		Pin Type	Buffer Type	Description
	DIL	QFN			
RA0/AN0/CVREF/VREF-/C1IN+/INT0/PGD RA0 AN0 CVREF VREF- C1IN+ INT0 PGD	19	16	I/O I O I I I I/O	TTL Analog Analog Analog Analog ST ST	Digital I/O ADC channel 0 DAC reference voltage output ADC and DAC reference voltage (low) input Comparator C1 non-inverting input External interrupt 0 ICSP™ programming data pin
RA1/AN1/C12IN0-/VREF+/INT1/PGC RA1 AN1 C12IN0- VREF+ INT1 PGC	18	15	I/O I I I I I/O	TTL Analog Analog Analog ST ST	Digital I/O ADC channel 1 Comparator C1 and C2 non-inverting input ADC and DAC reference voltage (high) input External interrupt 1 ICSP™ programming clock pin
RA2/AN2/C1OUT/T0CKI/INT2/SRQ RA2 AN2 C1OUT T0CKI INT2 SRQ	17	14	I/O I — I I O	ST Analog CMOS ST ST CMOS	Digital I/O ADC channel 2 Comparator C1 output Timer0 external clock input External interrupt 2 SR latch output
RA3/MCLR/VPP RA3 MCLR VPP	4	1	I I P	ST ST —	Digital input Active-low Master Clear with internal pull-up High voltage programming input
RA4/AN3/OSC2/CLKOUT RA4 AN3 OSC2 CLKOUT	3	20	I/O I O O	TTL Analog XTAL CMOS	Digital I/O ADC channel 3 Oscillator crystal output. Connect to crystal or resonator in Crystal Oscillator mode In RC mode, OSC2 pin outputs CLKOUT which has 1/4 the frequency of OSC1 and denotes the instruction cycle rate
RA5/OSC1/CLKIN/T13CKI RA5 OSC1 CLKIN T13CKI	2	19	I/O I I I	TTL XTAL CMOS ST	Digital I/O Oscillator crystal input or external clock input ST buffer when configured in RC mode; analog otherwise External clock source input. Always associated with the pin function OSC1 (See related OSC1/CLKIN, OSC2, CLKOUT pins) Timer0 and Timer3 external clock input
RB4/AN10/SDI/SDA RB4 AN10 SDI SDA	13	10	I/O I I I/O	TTL Analog ST ST	Digital I/O ADC channel 10 SPI data in I <sup>2</sup> C™ data I/O
RB5/AN11/RX/DT RB5 AN11 RX DT	12	9	I/O I I I/O	TTL Analog ST ST	Digital I/O ADC channel 11 EUSART asynchronous receive EUSART synchronous data (see related RX/TX)

**Legend:** TTL = TTL compatible input  
ST = Schmitt Trigger input  
O = Output  
XTAL = Crystal Oscillator

CMOS = CMOS compatible input or output  
I = Input  
P = Power

# PIC18(L)F1XK22

**TABLE 1-2: PIC18(L)F1XK22 PIN SUMMARY**

Pin Name	Pin Number		Pin Type	Buffer Type	Description
	D/L	C/F/Z			
RB6/SCK/SCL RB6 SCK SCL	11	8	I/O I/O I/O	TLL ST ST	Digital I/O Synchronous serial clock input/output for SPI mode Synchronous serial clock input/output for I <sup>2</sup> C™ mode
RB7/TX/CK RB7 TX CK	10	7	I/O O I/O	TLL CMOS ST	Digital I/O EUSART asynchronous transmit EUSART synchronous clock (see related RX/DT)
RC0/AN4/C2IN+ RC0 AN4 C2IN+	16	13	I/O I I	ST Analog Analog	Digital I/O ADC channel 4 Comparator C2 non-inverting input
RC1/AN5/C12IN-/INT1 RC1 AN5 C12IN- INT1	15	12	I/O I I I	ST Analog Analog ST	Digital I/O ADC channel 5 Comparator C1 and C2 non-inverting input External interrupt 0
RC2/AN6/C12IN2-/P1D/INT2 RC2 AN6 C12IN2- P1D	14	11	I/O I I O	ST Analog Analog CMOS	Digital I/O ADC channel 6 Comparator C1 and C2 inverting input Enhanced CCP1 PWM output
RC3/AN7/C12IN3-/P1C/PGM RC3 AN7 C12IN3- P1C PGM	7	4	I/O I I O I/O	ST Analog Analog CMOS ST	Digital I/O ADC channel 7 Comparator C1 and C2 inverting input Enhanced CCP1 PWM output Low-Voltage ICSP Programming enable pin
RC4/C12OUT/P1B/SRQ RC4 C12OUT P1B SRNQ	6	3	I/O O O O	ST CMOS CMOS CMOS	Digital I/O Comparator C1 and C2 output Enhanced CCP1 PWM output SR latch output
RC5/CCP1/P1A RC5 CCP1 P1A	5	2	I/O I/O O	ST ST CMOS	Digital I/O Capture 1 input/Compare 1 output/PWM 1 output Enhanced CCP1 PWM output
RC6/AN8/SS RC6 AN8 SS	8	5	I/O I I	ST Analog TTL	Digital I/O ADC channel 8 SPI slave select input
RC7/AN9/SDO RC7 AN9 SDO	9	6	I/O I O	ST Analog CMOS	Digital I/O ADC channel 9 SPI data out
VSS	20	17	P	—	Ground reference for logic and I/O pins
VDD	1	18	P	—	Positive supply for logic and I/O pins

**Legend:** TTL = TTL compatible input  
ST = Schmitt Trigger input  
O = Output  
XTAL = Crystal Oscillator

CMOS = CMOS compatible input or output  
I = Input  
P = Power

## 2.0 OSCILLATOR MODULE

### 2.1 Overview

The oscillator module has a variety of clock sources and features that allow it to be used in a wide range of applications, maximizing performance and minimizing power consumption. Figure 2-1 illustrates a block diagram of the oscillator module.

Key features of the oscillator module include:

- System Clocks
- System Clock Selection
  - Primary External Oscillator
  - Secondary External Oscillator
  - Internal Oscillator
- Oscillator Start-up Timer
- System Clock Selection
- Clock Switching
- 4x Phase Lock Loop Frequency Multiplier
- CPU Clock Divider
- Two-Speed Start-up Mode
- Fail-Safe Clock Monitoring

### 2.2 System Clocks

The PIC18(L)F1XK22 can be operated in 13 different oscillator modes. The user can program these using the available Configuration bits. In addition, clock support functions such as Fail-Safe and two Start-up can also be configured.

The available Primary oscillator options include:

- External Clock, low power (ECL)
- External Clock, medium power (ECM)
- External Clock, high power (ECH)
- External Clock, low power, CLKOUT function on RA4/OSC2 (ECCLKOUTL)
- External Clock, medium power, CLKOUT function on RA4/OSC2 (ECCLKOUTM)
- External Clock, high power, CLKOUT function on RA4/OSC2 (ECCLKOUTH)
- External Crystal (XT)
- High-speed Crystal (HS)
- Low-power crystal (LP)
- External Resistor/Capacitor (EXTRC)
- External RC, CLKOUT function on RA4/OSC2
- 31.25 kHz – 16 MHz internal oscillator (INTOSC)
- 31.25 kHz – 16 MHz internal oscillator, CLKOUT function on RA4/OSC2

Additionally, the 4xPLL may be enabled in hardware or software (under certain conditions) for increased oscillator speed.

### 2.3 System Clock Selection

The SCS bits of the OSCCON register select between the following clock sources:

- Primary External Oscillator
- Secondary External Oscillator
- Internal Oscillator

**Note:** The frequency of the system clock will be referred to as FOSC throughout this document.

**TABLE 2-1: SYSTEM CLOCK SELECTION**

Configuration	Selection
SCS <1:0>	System Clock
1x	Internal Oscillator
01	Secondary External Oscillator
00 (Default after Reset)	Oscillator defined by FOSC<3:0>

The default state of the SCS bits sets the system clock to be the oscillator defined by the FOSC bits of the CONFIG1H Configuration register. The system clock will always be defined by the FOSC bits until the SCS bits are modified in software.

When the Internal Oscillator is selected as the system clock, the IRCF bits of the OSCCON register and the INTSRC bit of the OSCTUNE register will select either the LFINTOSC or the HFINTOSC. The LFINTOSC is selected when the IRCF<2:0> = 000 and the INTSRC bit is clear. All other combinations of the IRCF bits and the INTSRC bit will select the HFINTOSC as the system clock.

### 2.4 Primary External Oscillator

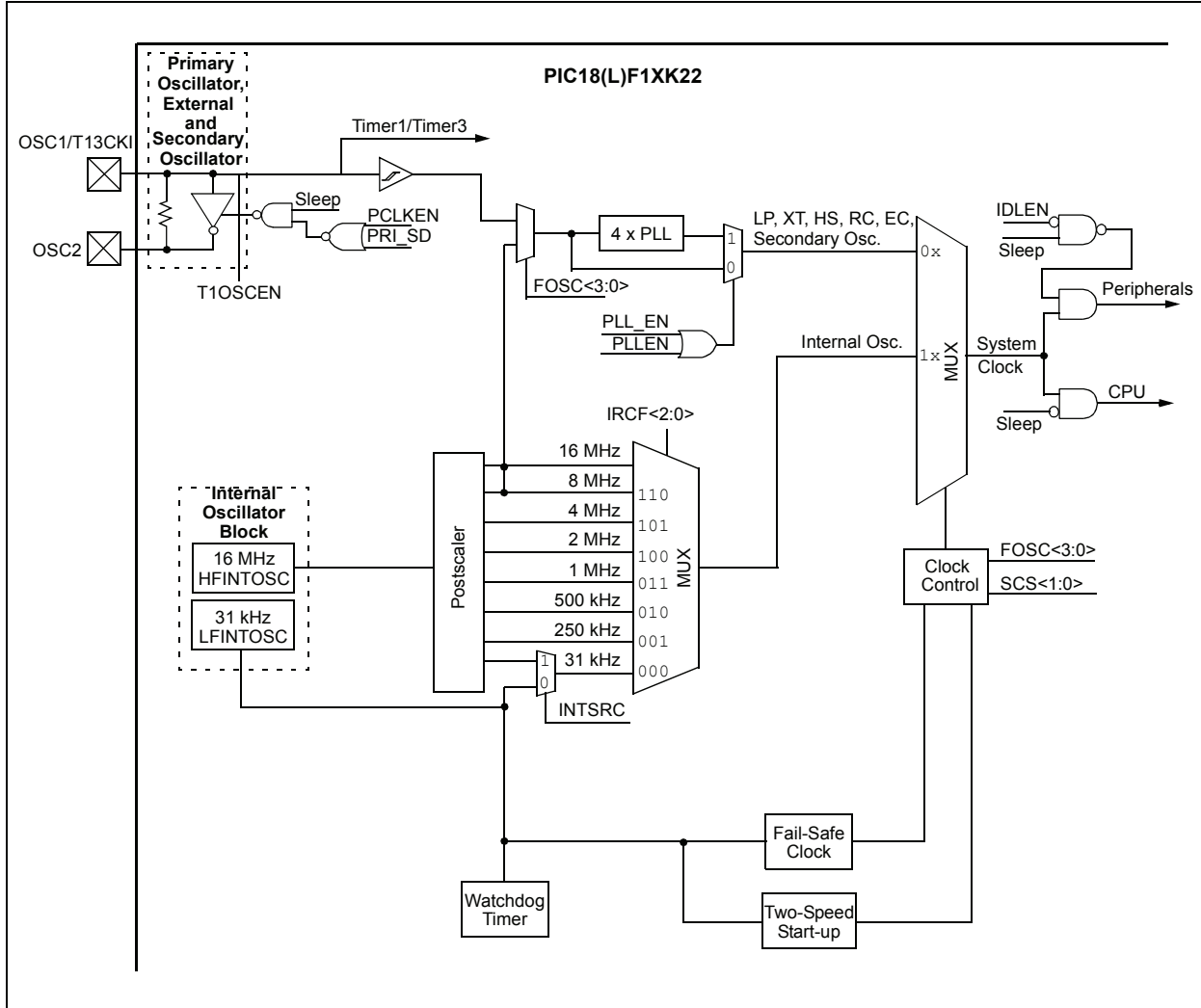
The Primary External Oscillator's mode of operation is selected by setting the FOSC<3:0> bits of the CONFIG1H Configuration register. The oscillator can be set to the following modes:

- LP: Low-Power Crystal
- XT: Crystal/Ceramic Resonator
- HS: High-Speed Crystal Resonator
- RC: External RC Oscillator
- EC: External Clock

Additionally, the Primary External Oscillator may be shut-down under firmware control to save power.

# PIC18(L)F1XK22

FIGURE 2-1: PIC® MCU CLOCK SOURCE BLOCK DIAGRAM



**Note:** If using a low-frequency external oscillator and want to multiple it by 4 via PLL, the ideal input frequency is from 4 MHz to 16 MHz.

## 2.4.1 PRIMARY EXTERNAL OSCILLATOR SHUT-DOWN

The Primary External Oscillator can be enabled or disabled via software. To enable software control of the Primary External Oscillator, the PCLKEN bit of the CONFIG1H Configuration register must be set. With the PCLKEN bit set, the Primary External Oscillator is controlled by the PRI\_SD bit of the OSCCON2 register. The Primary External Oscillator will be enabled when the PRI\_SD bit is set, and disabled when the PRI\_SD bit is clear.

**Note:** The Primary External Oscillator cannot be shut down when it is selected as the System Clock. To shut down the oscillator, the system clock source must be either the Secondary Oscillator or the Internal Oscillator.

## 2.4.2 LP, XT AND HS OSCILLATOR MODES

The LP, XT and HS modes support the use of quartz crystal resonators or ceramic resonators connected to OSC1 and OSC2 (Figure 2-2). The mode selects a low, medium or high gain setting of the internal inverter-amplifier to support various resonator types and speed.

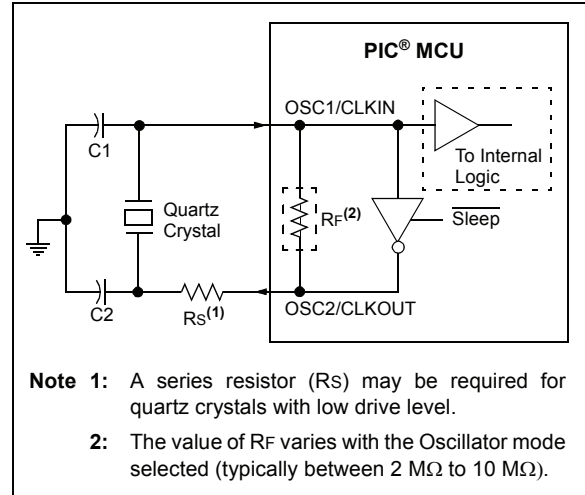
**LP** Oscillator mode selects the lowest gain setting of the internal inverter-amplifier. LP mode current consumption is the least of the three modes. This mode is best suited to drive resonators with a low drive level specification, for example, tuning fork type crystals.

**XT** Oscillator mode selects the intermediate gain setting of the internal inverter-amplifier. XT mode current consumption is the medium of the three modes. This mode is best suited to drive resonators with a medium drive level specification.

**HS** Oscillator mode selects the highest gain setting of the internal inverter-amplifier. HS mode current consumption is the highest of the three modes. This mode is best suited for resonators that require a high drive setting.

Figure 2-2 and Figure 2-3 show typical circuits for quartz crystal and ceramic resonators, respectively.

**FIGURE 2-2: QUARTZ CRYSTAL OPERATION (LP, XT OR HS MODE)**



**Note 1:** Quartz crystal characteristics vary according to type, package and manufacturer. The user should consult the manufacturer data sheets for specifications and recommended application.

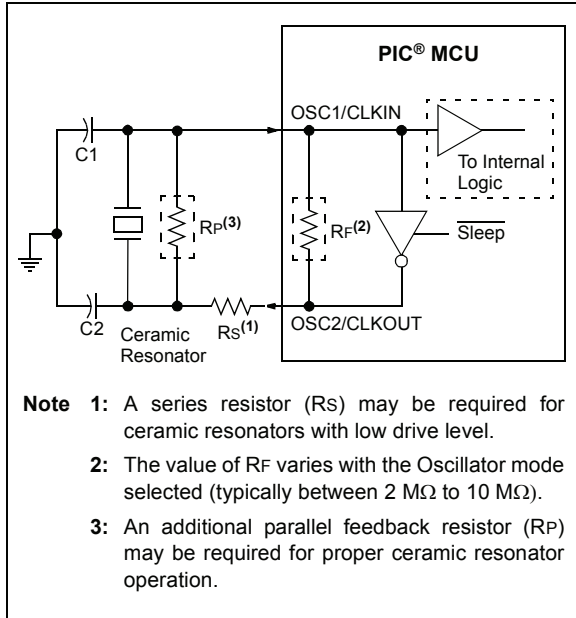
**2:** Always verify oscillator performance over the  $V_{DD}$  and temperature range that is expected for the application.

**3:** For oscillator design assistance, reference the following Microchip Applications Notes:

- AN826, "Crystal Oscillator Basics and Crystal Selection for  $\mu$ PIC<sup>®</sup> and PIC<sup>®</sup> Devices" (DS00826)
- AN849, "Basic PIC<sup>®</sup> Oscillator Design" (DS00849)
- AN943, "Practical PIC<sup>®</sup> Oscillator Analysis and Design" (DS00943)
- AN949, "Making Your Oscillator Work" (DS00949)

# PIC18(L)F1XK22

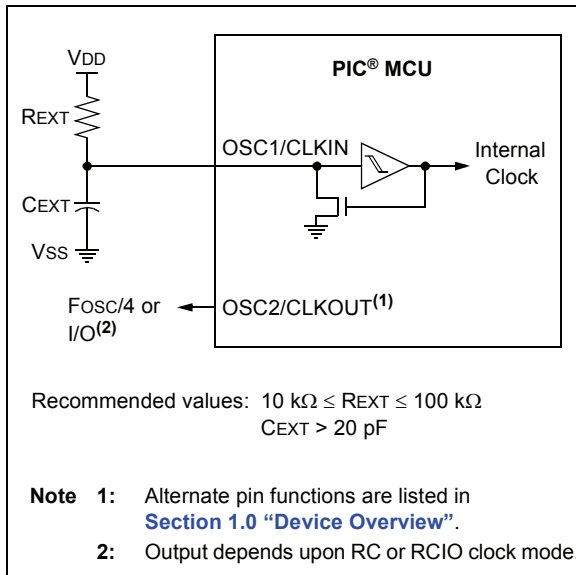
**FIGURE 2-3: CERAMIC RESONATOR OPERATION (XT OR HS MODE)**



## 2.4.3 EXTERNAL RC

The External Resistor-Capacitor (RC) mode supports the use of an external RC circuit. This allows the designer maximum flexibility in frequency choice while keeping costs to a minimum when clock accuracy is not required. In RC mode, the RC circuit connects to OSC1, allowing OSC2 to be configured as an I/O or as CLKOUT. The CLKOUT function is selected by the FOSC bits of the CONFIG1H Configuration register. When OSC2 is configured as CLKOUT, the frequency at the pin is the frequency of the RC oscillator divided by 4. Figure 2-4 shows the external RC mode connections.

**FIGURE 2-4: EXTERNAL RC MODES**



The RC oscillator frequency is a function of the supply voltage, the resistor  $R_{EXT}$ , the capacitor  $C_{EXT}$  and the operating temperature. Other factors affecting the oscillator frequency are:

- Input threshold voltage variation
- Component tolerances
- Variation in capacitance due to packaging

## 2.4.4 EXTERNAL CLOCK

The External Clock (EC) mode allows an externally generated logic level clock to be used as the system's clock source. When operating in this mode, the external clock source is connected to the OSC1 allowing OSC2 to be configured as an I/O or as CLKOUT. The CLKOUT function is selected by the FOSC bits of the CONFIG1H Configuration register. When OSC2 is configured as CLKOUT, the frequency at the pin is the frequency of the EC oscillator divided by 4.

Three different power settings are available for EC mode. The power settings allow for a reduced  $I_{DD}$  of the device, if the EC clock is known to be in a specific range. If there is an expected range of frequencies for the EC clock, select the power mode for the highest frequency.

EC	Low power	0 – 250 kHz
EC	Medium power	250 kHz – 4 MHz
EC	High power	4 – 64 MHz

## 2.5 Secondary External Oscillator

The Secondary External Oscillator is designed to drive an external 32.768 kHz crystal. This oscillator is enabled or disabled by the T1OSCEN bit of the T1CON register. See Section 10.0 "Timer1 Module" for more information.



## 2.6 Internal Oscillator

The internal oscillator module contains two independent oscillators which are:

- LFINTOSC: Low-Frequency Internal Oscillator
- HFINTOSC: High-Frequency Internal Oscillator

When operating with either oscillator, OSC1 will be an I/O and OSC2 will be either an I/O or CLKOUT. The CLKOUT function is selected by the FOSC bits of the CONFIG1H Configuration register. When OSC2 is configured as CLKOUT, the frequency at the pin is the frequency of the Internal Oscillator divided by 4.

### 2.6.1 LFINTOSC

The Low-Frequency Internal Oscillator (LFINTOSC) is a 31 kHz internal clock source. The LFINTOSC oscillator is the clock source for:

- Power-up Timer
- Watchdog Timer
- Fail-Safe Clock Monitor

The LFINTOSC is enabled when any of the following conditions are true:

- Power-up Timer is enabled (PWRTEN = 0)
- Watchdog Timer is enabled (WDTEN = 1)
- Watchdog Timer is enabled by software (WDTEN = 0 and SWDTEN = 1)
- Fail-Safe Clock Monitor is enabled (FCMEM = 1)
- SCS1 = 1 and IRCF<2:0> = 000 and INTSRC = 0
- FOSC<3:0> selects the internal oscillator as the primary clock and IRCF<2:0> = 000 and INTSRC = 0
- IESO = 1 (Two-Speed Start-up) and IRCF<2:0> = 000 and INTSRC = 0

### 2.6.2 HFINTOSC

The High-Frequency Internal Oscillator (HFINTOSC) is a precision oscillator that is factory-calibrated to operate at 16 MHz. The output of the HFINTOSC connects to a postscaler and a multiplexer (see [Figure 2-1](#)). One of eight frequencies can be selected using the IRCF<2:0> bits of the OSCCON register. The following frequencies are available from the HFINTOSC:

- 16 MHz
- 8 MHz
- 4 MHz
- 2 MHz
- 1 MHz (Default after Reset)
- 500 kHz
- 250 kHz
- 31 kHz

The HFIOFS bit of the OSCCON register indicates whether the HFINTOSC is stable.

**Note 1:** Selecting 31 kHz from the HFINTOSC oscillator requires IRCF<2:0> = 000 and the INTSRC bit of the OSCTUNE register to be set. If the INTSRC bit is clear, the system clock will come from the LFINTOSC.

**2:** Additional adjustments to the frequency of the HFINTOSC can be made via the OSCTUNE registers. See [Register 2-3](#) for more details.

The HFINTOSC is enabled if any of the following conditions are true:

- SCS1 = 1 and IRCF<2:0> ≠ 000
- SCS1 = 1 and IRCF<2:0> = 000 and INTSRC = 1
- FOSC<3:0> selects the internal oscillator as the primary clock and
  - IRCF<2:0> ≠ 000 or
  - IRCF<2:0> = 000 and INTSRC = 1
- IESO = 1 (Two-Speed Start-up) and
  - IRCF<2:0> ≠ 000 or
  - IRCF<2:0> = 000 and INTSRC = 1
- FCMEM = 1 (Fail-Safe Clock Monitoring) and
  - IRCF<2:0> ≠ 000 or
  - IRCF<2:0> = 000 and INTSRC = 1

# PIC18(L)F1XK22

## 2.7 Oscillator Control

The Oscillator Control (OSCCON) (Register 2-1) and the Oscillator Control 2 (OSCCON2) (Register 2-2) registers control the system clock and frequency selection options.

### REGISTER 2-1: OSCCON: OSCILLATOR CONTROL REGISTER

R/W-0	R/W-0	R/W-1	R/W-1	R-q	R-0	R/W-0	R/W-0
IDLEN	IRCF2	IRCF1	IRCF0	OSTS <sup>(1)</sup>	HFIOFS	SCS1	SCS0
bit 7							bit 0

#### Legend:

R = Readable bit	W = Writable bit	U = Unimplemented bit, read as '0'	q = depends on condition
-n = Value at POR	'1' = Bit is set	'0' = Bit is cleared	x = Bit is unknown

- bit 7      **IDLEN:** Idle Enable bit  
1 = Device enters Idle mode on `SLEEP` instruction  
0 = Device enters Sleep mode on `SLEEP` instruction
- bit 6-4    **IRCF<2:0>:** Internal Oscillator Frequency Select bits  
111 = 16 MHz  
110 = 8 MHz  
101 = 4 MHz  
100 = 2 MHz  
011 = 1 MHz<sup>(3)</sup>  
010 = 500 kHz  
001 = 250 kHz  
000 = 31 kHz<sup>(2)</sup>
- bit 3      **OSTS:** Oscillator Start-up Time-out Status bit<sup>(1)</sup>  
1 = Device is running from the clock defined by `FOSC<2:0>` of the `CONFIG1` register  
0 = Device is running from the internal oscillator (`HFINTOSC` or `LFINTOSC`)
- bit 2      **HFIOFS:** `HFINTOSC` Frequency Stable bit  
1 = `HFINTOSC` frequency is stable  
0 = `HFINTOSC` frequency is not stable
- bit 1-0    **SCS<1:0>:** System Clock Select bits  
1x = Internal oscillator block  
01 = Secondary (Timer1) oscillator  
00 = Primary clock (determined by `CONFIG1H[FOSC<3:0>]`).

- Note 1:** Reset state depends on state of the `IESO` Configuration bit.  
**2:** Source selected by the `INTSRC` bit of the `OSCTUNE` register, see text.  
**3:** Default output frequency of `HFINTOSC` on Reset.

## REGISTER 2-2: OSCCON2: OSCILLATOR CONTROL REGISTER 2

U-0	U-0	U-0	U-0	U-0	R/W-1	R/W-0	R-x
—	—	—	—	—	PRI_SD	HFIOFL	LFIOFS
bit 7						bit 0	

### Legend:

R = Readable bit	W = Writable bit	U = Unimplemented bit, read as '0'	q = depends on condition
-n = Value at POR	'1' = Bit is set	'0' = Bit is cleared	x = Bit is unknown

- bit 7-3      **Unimplemented:** Read as '0'
- bit 2      **PRI\_SD:** Primary Oscillator Drive Circuit shutdown bit
  - 1 = Oscillator drive circuit on
  - 0 = Oscillator drive circuit off (zero power)
- bit 1      **HFIOFL:** HFINTOSC Frequency Locked bit
  - 1 = HFINTOSC is in lock
  - 0 = HFINTOSC has not yet locked
- bit 0      **LFIOFS:** LFINTOSC Frequency Stable bit
  - 1 = LFINTOSC is stable
  - 0 = LFINTOSC is not stable

# PIC18(L)F1XK22

## 2.7.1 OSCTUNE REGISTER

The HFINTOSC is factory calibrated, but can be adjusted in software by writing to the TUN<5:0> bits of the OSCTUNE register (Register 2-3).

The default value of the TUN<5:0> is '000000'. The value is a 6-bit two's complement number.

When the OSCTUNE register is modified, the HFINTOSC frequency will begin shifting to the new frequency. Code execution continues during this shift, while giving no indication that the shift has occurred.

OSCTUNE does not affect the LFINTOSC frequency. The operation of features that depend on the LFINTOSC clock source frequency, such as the Power-up Timer

(PWRT), Watchdog Timer (WDT), Fail-Safe Clock Monitor (FSCM) and peripherals, are *not* affected by the change in frequency.

The OSCTUNE register also implements the INTSRC and PLEN bits, which control certain features of the internal oscillator block.

The INTSRC bit allows users to select which internal oscillator provides the clock source when the 31 kHz frequency option is selected. This is covered in greater detail in [Section 2.6.1 "LFINTOSC"](#).

The PLEN bit controls the operation of the frequency multiplier. For more details about the function of the PLEN bit see [Section 2.10 "4x Phase Lock Loop Frequency Multiplier"](#)

## REGISTER 2-3: OSCTUNE: OSCILLATOR TUNING REGISTER

R/W-0	R/W-0	R/W-0	R/W-0	R/W-0	R/W-0	R/W-0	R/W-0
INTSRC	PLEN	TUN5	TUN4	TUN3	TUN2	TUN1	TUN0
bit 7							bit 0

### Legend:

R = Readable bit	W = Writable bit	U = Unimplemented bit, read as '0'
-n = Value at POR	'1' = Bit is set	'0' = Bit is cleared      x = Bit is unknown

- bit 7      **INTSRC:** Internal Oscillator Low-Frequency Source Select bit
  - 1 = 31.25 kHz device clock derived from 16 MHz HFINTOSC source (divide-by-512 enabled)
  - 0 = 31 kHz device clock derived directly from LFINTOSC internal oscillator
- bit 6      **PLEN:** Frequency Multiplier PLL bit
  - 1 = PLL enabled (for HFINTOSC 8 MHz and 16 MHz only)
  - 0 = PLL disabled
- bit 5-0    **TUN<5:0>:** Frequency Tuning bits
  - 011111 = Maximum frequency
  - 011110 =
  - ...
  - 000001 =
  - 000000 = Oscillator module is running at the factory calibrated frequency.
  - 111111 =
  - ...
  - 100000 = Minimum frequency

## 2.8 Oscillator Start-up Timer

The Primary External Oscillator, when configured for LP, XT or HS modes, incorporates an Oscillator Start-up Timer (OST). The OST ensures that the oscillator starts and provides a stable clock to the oscillator module. The OST times out when 1024 oscillations on OSC1 have occurred. During the OST period, with the system clock set to the Primary External Oscillator, the program counter does not increment suspending program execution. The OST period will occur following:

- Power-on Reset (POR)
- Brown-out Reset (BOR)
- Wake-up from Sleep
- Oscillator being enabled
- Expiration of Power-up Timer (PWRT)

In order to minimize latency between external oscillator start-up and code execution, the Two-Speed Start-up mode can be selected. See [Section 2.11 “Two-Speed Start-up Mode”](#) for more information.

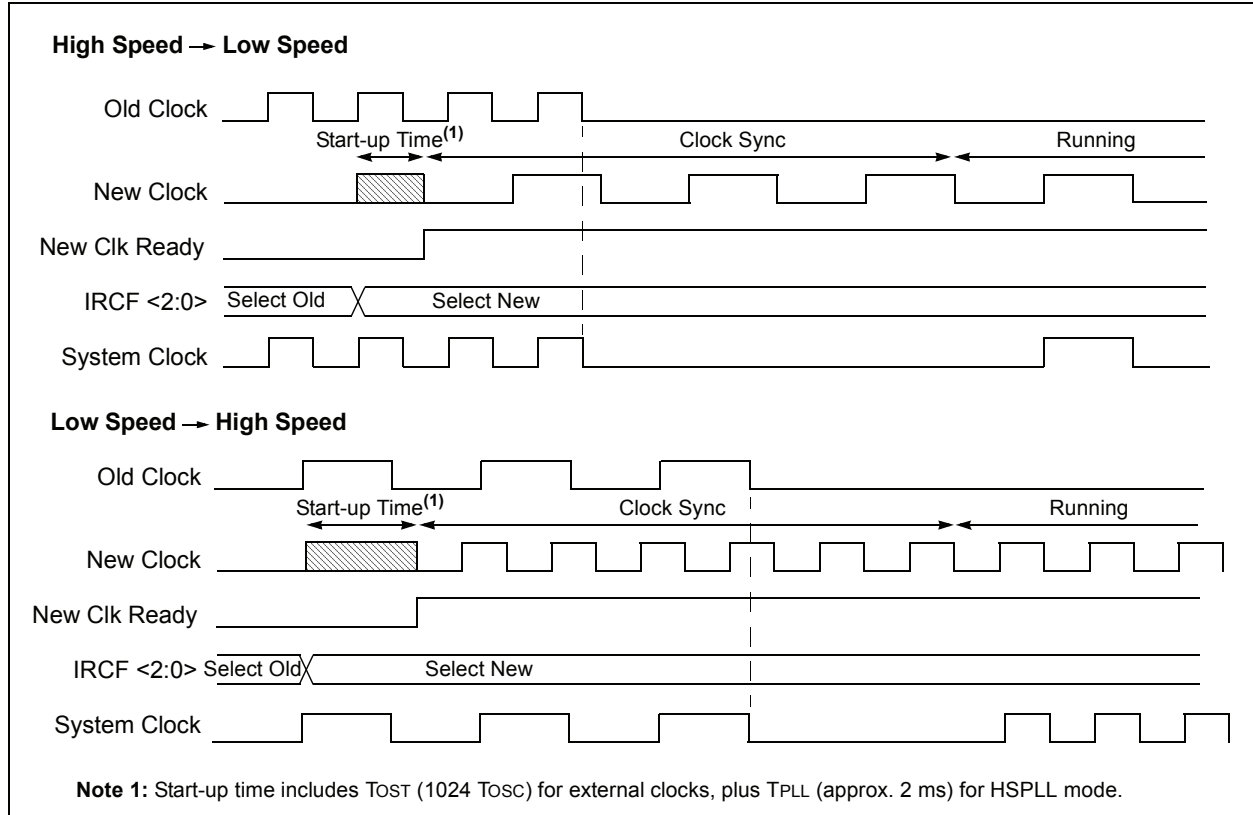
## 2.9 Clock Switching

The device contains circuitry to prevent clock “glitches” due to a change of the system clock source. To accomplish this, a short pause in the system clock occurs during the clock switch. If the new clock source is not stable (e.g., OST is active), the device will continue to execute from the old clock source until the new clock source becomes stable. The timing of a clock switch is as follows:

1. SCS<1:0> bits of the OSCCON register are modified.
2. The system clock will continue to operate from the old clock until the new clock is ready.
3. Clock switch circuitry waits for two consecutive rising edges of the old clock after the new clock is ready.
4. The system clock is held low, starting at the next falling edge of the old clock.
5. Clock switch circuitry waits for an additional two rising edges of the new clock.
6. On the next falling edge of the new clock, the low hold on the system clock is release and the new clock is switched in as the system clock.
7. Clock switch is complete.

Refer to [Figure 2-5](#) for more details.

**FIGURE 2-5: CLOCK SWITCH TIMING**



# PIC18(L)F1XK22

**TABLE 2-2: EXAMPLES OF DELAYS DUE TO CLOCK SWITCHING**

Switch From	Switch To	Oscillator Delay
Sleep/POR	LFINTOSC HFINTOSC	Oscillator Warm-up Delay (TWARM)
Sleep/POR	LP, XT, HS	1024 clock cycles
Sleep/POR	EC, RC	8 Clock Cycles

## 2.10 4x Phase Lock Loop Frequency Multiplier

A Phase Locked Loop (PLL) circuit is provided as an option for users who wish to use a lower-frequency external oscillator or to operate at 32 MHz or 64 MHz with the HFINTOSC. The PLL is designed for an input frequency from 4 MHz to 16 MHz. The PLL multiplies its input frequency by a factor of four when the PLL is enabled. This may be useful for customers who are concerned with EMI, due to high-frequency crystals.

Two bits control the PLL: the PLL\_EN bit of the CONFIG1H Configuration register and the PLEN bit of the OSCTUNE register. The PLL is enabled when the PLL\_EN bit is set and it is under software control when the PLL\_EN bit is cleared. Refer to [Table 2-3](#) and [Table 2-4](#) for more information.

**TABLE 2-3: PLL CONFIGURATION**

PLL_EN	PLEN	PLL Status
1	x	PLL enabled
0	1	PLL enabled
0	0	PLL disabled

**TABLE 2-4: PLL CONFIG1H/SOFTWARE ENABLE CLOCK SOURCE RESTRICTIONS**

Mode	PLL CONFIG1H Enable (PLL_EN)	PLL Software Enable (PLEN)
LP	Yes	No
XT	Yes	No
HS	Yes	No
EC	Yes	No
EXTRC	Yes	No
LF INTOSC	No	No
HF INTOSC	8/16 MHz	8/16 MHz

## 2.11 Two-Speed Start-up Mode

Two-Speed Start-up mode provides additional power savings by minimizing the latency between external Oscillator Start-up Timer (OST) and code execution. In applications that make heavy use of the Sleep mode, Two-Speed Start-up will remove the OST period, which can reduce the overall power consumption of the device.

Two-Speed Start-up mode is enabled by setting the IESO bit of the CONFIG1H Configuration register. With Two-Speed Start-up enabled, the device will execute instructions using the internal oscillator during the Primary External Oscillator OST period.

When the system clock is set to the Primary External Oscillator and the oscillator is configured for LP, XT or HS modes, the device will not execute code during the OST period. The OST will suspend program execution until 1024 oscillations are counted. Two-Speed Start-up mode minimizes the delay in code execution by operating from the internal oscillator while the OST is active. The system clock will switch back to the Primary External Oscillator after the OST period has expired.

Two-speed Start-up will become active after:

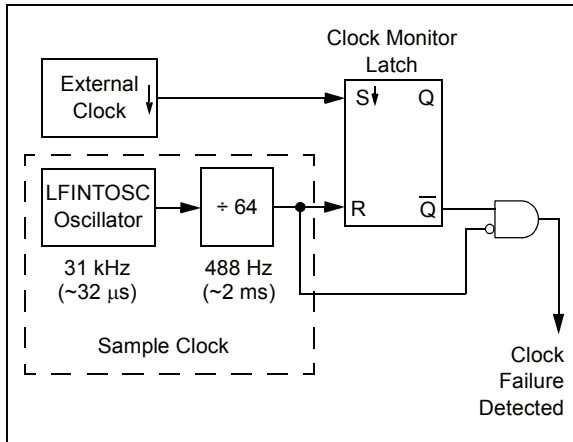
- Power-on Reset (POR)
- Power-up Timer (PWRT), if enabled
- Wake-up from Sleep

The OSTS bit of the OSCCON register reports which oscillator the device is currently using for operation. The device is running from the oscillator defined by the FOSC bits of the CONFIG1H Configuration register when the OSTS bit is set. The device is running from the internal oscillator when the OSTS bit is clear.

## 2.12 Fail-Safe Clock Monitor

The Fail-Safe Clock Monitor (FSCM) allows the device to continue operating should the external oscillator fail. The FSCM can detect oscillator failure any time after the Oscillator Start-up Timer (OST) has expired. The FSCM is enabled by setting the FCMEN bit in the CONFIG1H Configuration register. The FSCM is applicable to all external oscillator modes (LP, XT, HS, EC and RC).

**FIGURE 2-6: FSCM BLOCK DIAGRAM**



### 2.12.1 FAIL-SAFE DETECTION

The FSCM module detects a failed oscillator by comparing the external oscillator to the FSCM sample clock. The sample clock is generated by dividing the LFINTOSC by 64. See Figure 2-6. Inside the fail detector block is a latch. The external clock sets the latch on each falling edge of the external clock. The sample clock clears the latch on each rising edge of the sample clock. A failure is detected when an entire half-cycle of the sample clock elapses before the primary clock goes low.

### 2.12.2 FAIL-SAFE OPERATION

When the external clock fails, the FSCM switches the device clock to an internal clock source and sets the bit flag OSCFIF of the PIR2 register. The OSCFIF flag will generate an interrupt if the OSCFIE bit of the PIE2 register is also set. The device firmware can then take steps to mitigate the problems that may arise from a failed clock. The system clock will continue to be sourced from the internal clock source until the device firmware successfully restarts the external oscillator and switches back to external operation. An automatic transition back to the failed clock source will not occur.

The internal clock source chosen by the FSCM is determined by the IRCF<2:0> bits of the OSCCON register. This allows the internal oscillator to be configured before a failure occurs.

### 2.12.3 FAIL-SAFE CONDITION CLEARING

The Fail-Safe condition is cleared by either one of the following:

- Any Reset
- By toggling the SCS1 bit of the OSCCON register

Both of these conditions restart the OST. While the OST is running, the device continues to operate from the INTOSC selected in OSCCON. When the OST times out, the Fail-Safe condition is cleared and the device automatically switches over to the external clock source. The Fail-Safe condition need not be cleared before the OSCFIF flag is cleared.

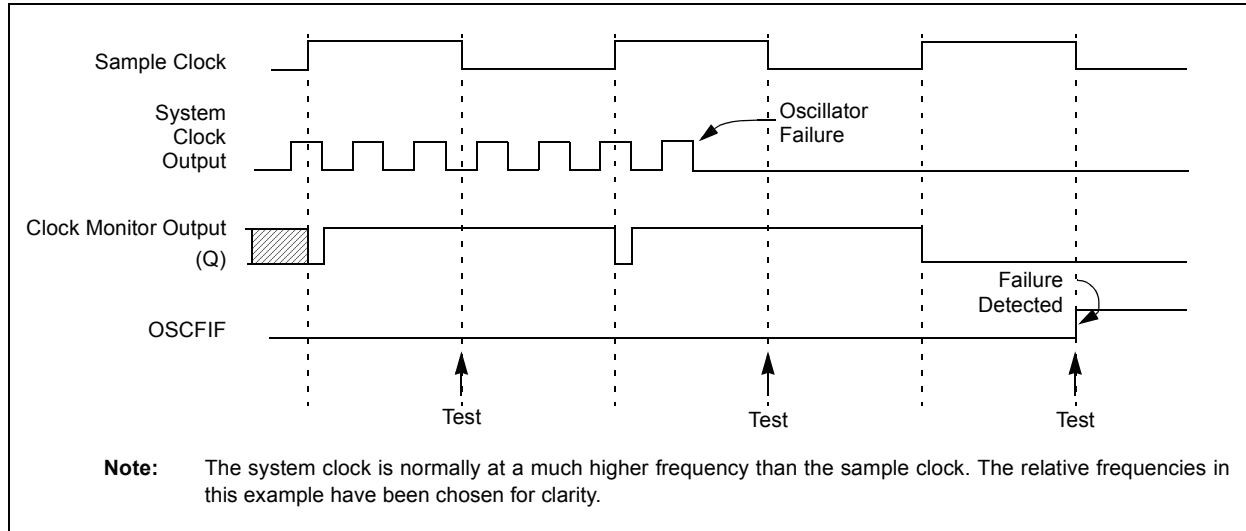
### 2.12.4 RESET OR WAKE-UP FROM SLEEP

The FSCM is designed to detect an oscillator failure after the Oscillator Start-up Timer (OST) has expired. The OST is used after waking up from Sleep and after any type of Reset. The OST is not used with the EC or RC Clock modes so that the FSCM will be active as soon as the Reset or wake-up has completed. When the FSCM is enabled, the Two-Speed Start-up is also enabled. Therefore, the device will always be executing code while the OST is operating.

**Note:** Due to the wide range of oscillator start-up times, the Fail-Safe circuit is not active during oscillator start-up (i.e., after exiting Reset or Sleep). After an appropriate amount of time, the user should check the OSTS bit of the OSCCON register to verify the oscillator start-up and that the system clock switchover has successfully completed.

# PIC18(L)F1XK22

**FIGURE 2-7: FSCM TIMING DIAGRAM**



**TABLE 2-5: SUMMARY OF REGISTERS ASSOCIATED WITH CLOCK SOURCES**

Name	Bit 7	Bit 6	Bit 5	Bit 4	Bit 3	Bit 2	Bit 1	Bit 0	Reset Values on page
CONFIG1H	IESO	FCMEN	PCLKEN	PLL_EN	FOSC3	FOSC2	FOSC1	FOSC0	259
INTCON	GIE/GIEH	PEIE/GIEL	TMR0IE	INT0IE	RABIE	TMR0IF	INT0IF	RABIF	253
OSCCON	IDLEN	IRCF2	IRCF1	IRCF0	OSTS	HFIOFS	SCS1	SCS0	254
OSCCON2	—	—	—	—	—	PRI_SD	HFIOFL	LFIOFS	254
OSCTUNE	INTSRC	PLLEN	TUN5	TUN4	TUN3	TUN2	TUN1	TUN0	256
IPR2	OSCFIP	C1IP	C2IP	EEIP	BCLIP	—	TMR3IP	—	256
PIE2	OSCFIE	C1IE	C2IE	EEIE	BCLIE	—	TMR3IE	—	256
PIR2	OSCFIF	C1IF	C2IF	EEIF	BCLIF	—	TMR3IF	—	256
T1CON	RD16	T1RUN	T1CKPS1	T1CKPS0	T1OSCN	T1SYN $\bar{C}$	TMR1CS	TMR1ON	254

**Legend:** x = unknown, u = unchanged, - = unimplemented locations read as '0'. Shaded cells are not used by oscillators.

**Note 1:** Other (non Power-up) Resets include MCLR Reset and Watchdog Timer Reset during normal operation.



## 3.0 MEMORY ORGANIZATION

There are three types of memory in PIC18 Enhanced microcontroller devices:

- Program Memory
- Data RAM
- Data EEPROM

As Harvard architecture devices, the data and program memories use separate busses; this allows for concurrent access of the two memory spaces. The data EEPROM, for practical purposes, can be regarded as a peripheral device, since it is addressed and accessed through a set of control registers.

Additional detailed information on the operation of the Flash program memory is provided in [Section 4.0 “Flash Program Memory”](#). Data EEPROM is discussed separately in [Section 5.0 “Data EEPROM Memory”](#).

## 3.1 Program Memory Organization

PIC18 microcontrollers implement a 21-bit program counter, which is capable of addressing a 2-Mbyte Program Memory (PC) space. Accessing a location between the upper boundary of the physically implemented memory and the 2-Mbyte address will return all ‘0’s (a NOP instruction).

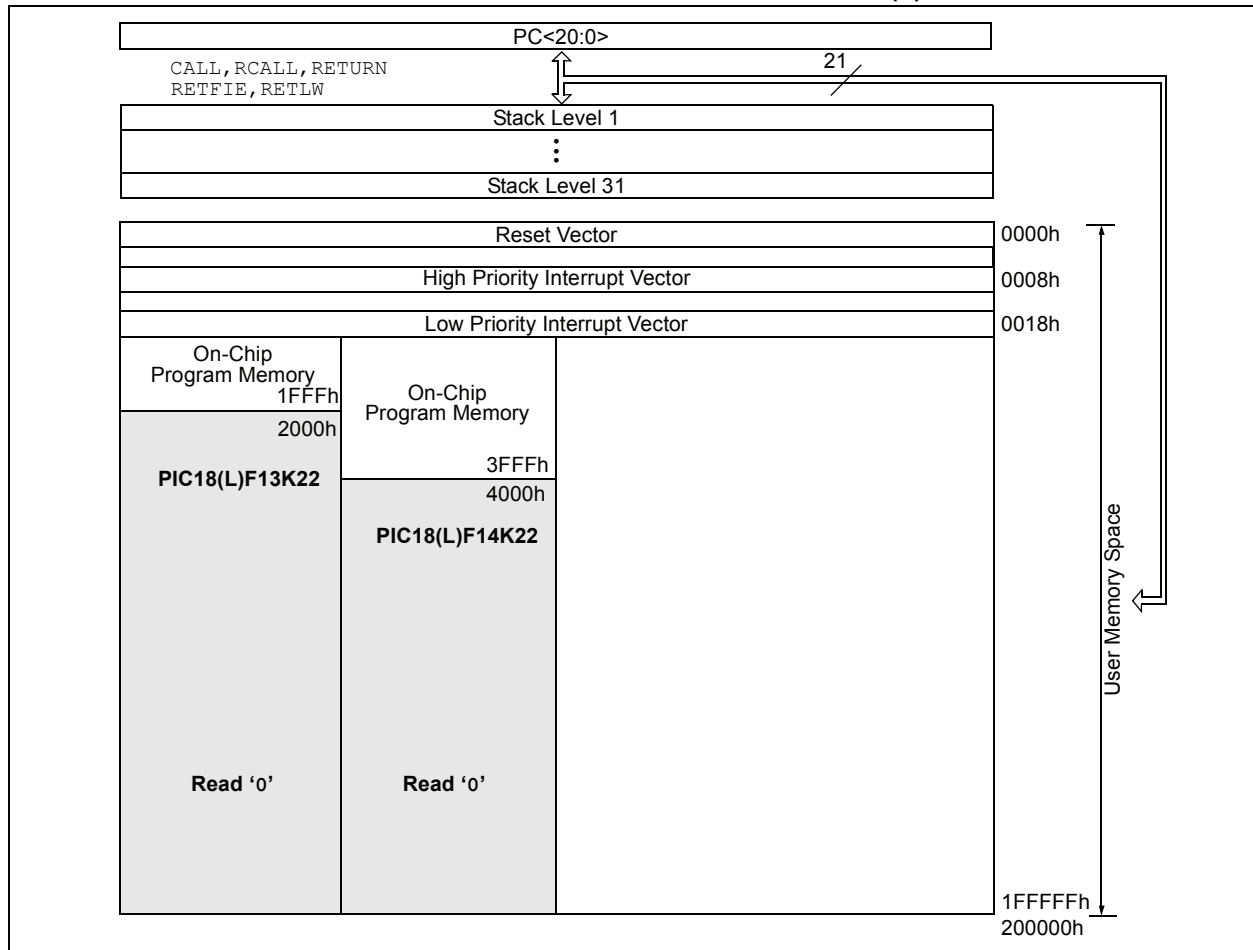
This family of devices contain the following:

- PIC18(L)F13K22: 8 Kbytes of Flash Memory, up to 4,096 single-word instructions
- PIC18(L)F14K22: 16 Kbytes of Flash Memory, up to 8,192 single-word instructions

PIC18 devices have two interrupt vectors and one Reset vector. The Reset vector address is at 0000h and the interrupt vector addresses are at 0008h and 0018h.

The program memory map for PIC18(L)F1XK22 devices is shown in [Figure 3-1](#). Memory block details are shown in [Figure 22-2](#).

**FIGURE 3-1: PROGRAM MEMORY MAP AND STACK FOR PIC18(L)F1XK22 DEVICES**



# PIC18(L)F1XK22

## 3.1.1 PROGRAM COUNTER

The Program Counter (PC) specifies the address of the instruction to fetch for execution. The PC is 21 bits wide and is contained in three separate 8-bit registers. The low byte, known as the PCL register, is both readable and writable. The high byte, or PCH register, contains the PC<15:8> bits; it is not directly readable or writable. Updates to the PCH register are performed through the PCLATH register. The upper byte is called PCU. This register contains the PC<20:16> bits; it is also not directly readable or writable. Updates to the PCU register are performed through the PCLATU register.

The contents of PCLATH and PCLATU are transferred to the program counter by any operation that writes PCL. Similarly, the upper two bytes of the program counter are transferred to PCLATH and PCLATU by an operation that reads PCL. This is useful for computed offsets to the PC (see [Section 3.1.4.1 “Computed GOTO”](#)).

The PC addresses bytes in the program memory. To prevent the PC from becoming misaligned with word instructions, the Least Significant bit (LSb) of PCL is fixed to a value of ‘0’. The PC increments by 2 to address sequential instructions in the program memory.

The CALL, RCALL, GOTO and program branch instructions write to the program counter directly. For these instructions, the contents of PCLATH and PCLATU are not transferred to the program counter.

## 3.1.2 RETURN ADDRESS STACK

The return address stack allows any combination of up to 31 program calls and interrupts to occur. The PC is pushed onto the stack when a CALL or RCALL instruction is executed or an interrupt is Acknowledged. The PC value is pulled off the stack on a RETURN, RETLW or a RETFIE instruction. PCLATU and PCLATH are not affected by any of the RETURN or CALL instructions.

The stack operates as a 31-word by 21-bit RAM and a 5-bit Stack Pointer, STKPTR. The stack space is not part of either program or data space. The Stack Pointer is readable and writable and the address on the top of the stack is readable and writable through the Top-of-Stack (TOS) Special File Registers. Data can also be pushed to, or popped from the stack, using these registers.

A CALL type instruction causes a push onto the stack; the Stack Pointer is first incremented and the location pointed to by the Stack Pointer is written with the contents of the PC (already pointing to the instruction following the CALL). A RETURN type instruction causes a pop from the stack; the contents of the location pointed to by the STKPTR are transferred to the PC and then the Stack Pointer is decremented.

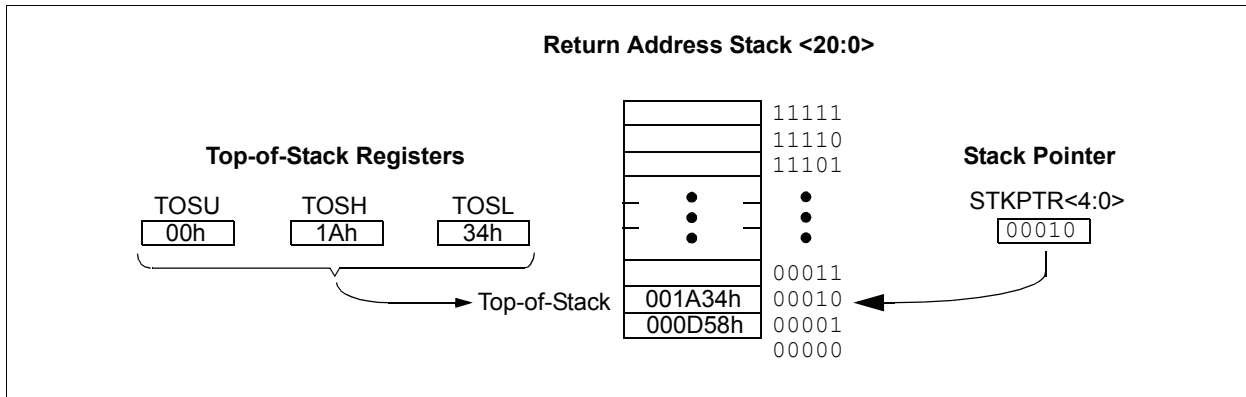
The Stack Pointer is initialized to ‘00000’ after all Resets. There is no RAM associated with the location corresponding to a Stack Pointer value of ‘00000’; this is only a Reset value. Status bits indicate if the stack is full or has overflowed or has underflowed.

### 3.1.2.1 Top-of-Stack Access

Only the top of the return address stack (TOS) is readable and writable. A set of three registers, TOSU:TOSH:TOSL, hold the contents of the stack location pointed to by the STKPTR register ([Figure 3-2](#)). This allows users to implement a software stack if necessary. After a CALL, RCALL or interrupt, the software can read the pushed value by reading the TOSU:TOSH:TOSL registers. These values can be placed on a user defined software stack. At return time, the software can return these values to TOSU:TOSH:TOSL and do a return.

The user must disable the global interrupt enable bits while accessing the stack to prevent inadvertent stack corruption.

**FIGURE 3-2: RETURN ADDRESS STACK AND ASSOCIATED REGISTERS**



### 3.1.2.2 Return Stack Pointer (STKPTR)

The STKPTR register (Register 3-1) contains the Stack Pointer value, the STKFUL (Stack Full) bit and the STKUNF (Stack Underflow) bits. The value of the Stack Pointer can be 0 through 31. The Stack Pointer increments before values are pushed onto the stack and decrements after values are popped off the stack. On Reset, the Stack Pointer value will be zero. The user may read and write the Stack Pointer value. This feature can be used by a Real-Time Operating System (RTOS) for return stack maintenance.

After the PC is pushed onto the stack 31 times (without popping any values off the stack), the STKFUL bit is set. The STKOVF bit is cleared by software or by a POR.

The action that takes place when the stack becomes full depends on the state of the STVREN (Stack Overflow Reset Enable) Configuration bit. (Refer to Section 22.1 “Configuration Bits” for a description of the device Configuration bits.) If STVREN is set (default), the 31st push will push the (PC + 2) value onto the stack, set the STKOVF bit and reset the device. The STKOVF bit will remain set and the Stack Pointer will be set to zero.

If STVREN is cleared, the STKOVF bit will be set on the 31st push and the Stack Pointer will increment to 31. Any additional pushes will not overwrite the 31st push and STKPTR will remain at 31.

When the stack has been popped enough times to unload the stack, the next pop will return a value of zero to the PC and sets the STKUNF bit, while the Stack Pointer remains at zero. The STKUNF bit will remain set until cleared by software or until a POR occurs.

**Note:** Returning a value of zero to the PC on an underflow has the effect of vectoring the program to the Reset vector, where the stack conditions can be verified and appropriate actions can be taken. This is not the same as a Reset, as the contents of the SFRs are not affected.

### 3.1.2.3 PUSH and POP Instructions

Since the Top-of-Stack is readable and writable, the ability to push values onto the stack and pull values off the stack without disturbing normal program execution is a desirable feature. The PIC18 instruction set includes two instructions, PUSH and POP, that permit the TOS to be manipulated under software control. TOSU, TOSH and TOSL can be modified to place data or a return address on the stack.

The PUSH instruction places the current PC value onto the stack. This increments the Stack Pointer and loads the current PC value onto the stack.

The POP instruction discards the current TOS by decrementing the Stack Pointer. The previous value pushed onto the stack then becomes the TOS value.

## REGISTER 3-1: STKPTR: STACK POINTER REGISTER

R/C-0	R/C-0	U-0	R/W-0	R/W-0	R/W-0	R/W-0	R/W-0
STKOVF <sup>(1)</sup>	STKUNF <sup>(1)</sup>	—	SP4	SP3	SP2	SP1	SP0
bit 7							bit 0

<b>Legend:</b>			
R = Readable bit	W = Writable bit	U = Unimplemented	C = Clearable only bit
-n = Value at POR	'1' = Bit is set	'0' = Bit is cleared	x = Bit is unknown

- bit 7      **STKOVF:** Stack Overflow Flag bit<sup>(1)</sup>  
             1 = Stack became full or overflowed  
             0 = Stack has not become full or overflowed
- bit 6      **STKUNF:** Stack Underflow Flag bit<sup>(1)</sup>  
             1 = Stack underflow occurred  
             0 = Stack underflow did not occur
- bit 5      **Unimplemented:** Read as '0'
- bit 4-0    **SP<4:0>:** Stack Pointer Location bits

**Note 1:** Bit 7 and bit 6 are cleared by user software or by a POR.

# PIC18(L)F1XK22

## 3.1.2.4 Stack Overflow and Underflow Resets

Device Resets on Stack Overflow and Stack Underflow conditions are enabled by setting the STVREN bit in Configuration Register 4L. When STVREN is set, a full or underflow will set the appropriate STKOVF or STKUNF bit and then cause a device Reset. When STVREN is cleared, a full or underflow condition will set the appropriate STKOVF or STKUNF bit but not cause a device Reset. The STKOVF or STKUNF bits are cleared by the user software or a Power-on Reset.

## 3.1.3 FAST REGISTER STACK

A fast register stack is provided for the STATUS, WREG and BSR registers, to provide a “fast return” option for interrupts. The stack for each register is only one level deep and is neither readable nor writable. It is loaded with the current value of the corresponding register when the processor vectors for an interrupt. All interrupt sources will push values into the stack registers. The values in the registers are then loaded back into their associated registers if the RETFIE, FAST instruction is used to return from the interrupt.

If both low and high priority interrupts are enabled, the stack registers cannot be used reliably to return from low priority interrupts. If a high priority interrupt occurs while servicing a low priority interrupt, the stack register values stored by the low priority interrupt will be overwritten. In these cases, users must save the key registers by software during a low priority interrupt.

If interrupt priority is not used, all interrupts may use the fast register stack for returns from interrupt. If no interrupts are used, the fast register stack can be used to restore the STATUS, WREG and BSR registers at the end of a subroutine call. To use the fast register stack for a subroutine call, a CALL label, FAST instruction must be executed to save the STATUS, WREG and BSR registers to the fast register stack. A RETURN, FAST instruction is then executed to restore these registers from the fast register stack.

Example 3-1 shows a source code example that uses the fast register stack during a subroutine call and return.

### EXAMPLE 3-1: FAST REGISTER STACK CODE EXAMPLE

```
CALL SUB1, FAST    ;STATUS, WREG, BSR
                  ;SAVED IN FAST REGISTER
                  ;STACK
.
.
SUB1 .
.
RETURN, FAST      ;RESTORE VALUES SAVED
                  ;IN FAST REGISTER STACK
```

## 3.1.4 LOOK-UP TABLES IN PROGRAM MEMORY

There may be programming situations that require the creation of data structures, or look-up tables, in program memory. For PIC18 devices, look-up tables can be implemented in two ways:

- Computed GOTO
- Table Reads

### 3.1.4.1 Computed GOTO

A computed GOTO is accomplished by adding an offset to the program counter. An example is shown in Example 3-2.

A look-up table can be formed with an ADDWF PCL instruction and a group of RETLW nn instructions. The W register is loaded with an offset into the table before executing a call to that table. The first instruction of the called routine is the ADDWF PCL instruction. The next instruction executed will be one of the RETLW nn instructions that returns the value ‘nn’ to the calling function.

The offset value (in WREG) specifies the number of bytes that the program counter should advance and should be multiples of 2 (LSb = 0).

In this method, only one data byte may be stored in each instruction location and room on the return address stack is required.

### EXAMPLE 3-2: COMPUTED GOTO USING AN OFFSET VALUE

```
MOVWF OFFSET, W
CALL TABLE
ORG nn00h
TABLE ADDWF PCL
      RETLW nnh
      RETLW nnh
      RETLW nnh
      .
      .
      .
```

### 3.1.4.2 Table Reads and Table Writes

A better method of storing data in program memory allows two bytes of data to be stored in each instruction location.

Look-up table data may be stored two bytes per program word by using table reads and writes. The Table Pointer (TBLPTR) register specifies the byte address and the Table Latch (TABLAT) register contains the data that is read from or written to program memory. Data is transferred to or from program memory one byte at a time.

Table read and table write operations are discussed further in Section 4.1 “Table Reads and Table Writes”.

## 3.2 PIC18 Instruction Cycle

### 3.2.1 CLOCKING SCHEME

The microcontroller clock input, whether from an internal or external source, is internally divided by four to generate four non-overlapping quadrature clocks (Q1, Q2, Q3 and Q4). Internally, the program counter is incremented on every Q1; the instruction is fetched from the program memory and latched into the instruction register during Q4. The instruction is decoded and executed during the following Q1 through Q4. The clocks and instruction execution flow are shown in Figure 3-3.

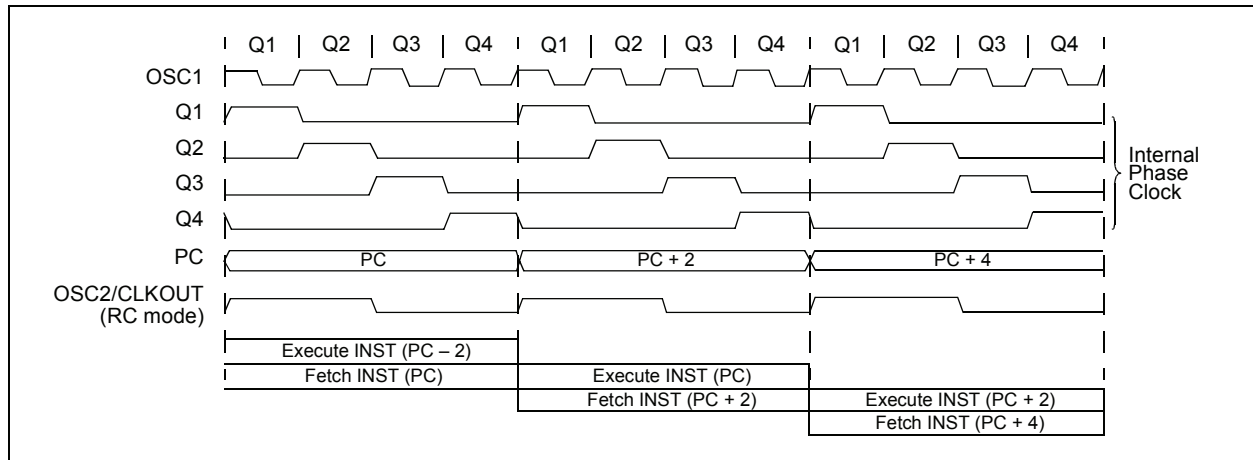
### 3.2.2 INSTRUCTION FLOW/PIPELINING

An "Instruction Cycle" consists of four Q cycles: Q1 through Q4. The instruction fetch and execute are pipelined in such a manner that a fetch takes one instruction cycle, while the decode and execute take another instruction cycle. However, due to the pipelining, each instruction effectively executes in one cycle. If an instruction causes the program counter to change (e.g., GOTO), then two cycles are required to complete the instruction (Example 3-3).

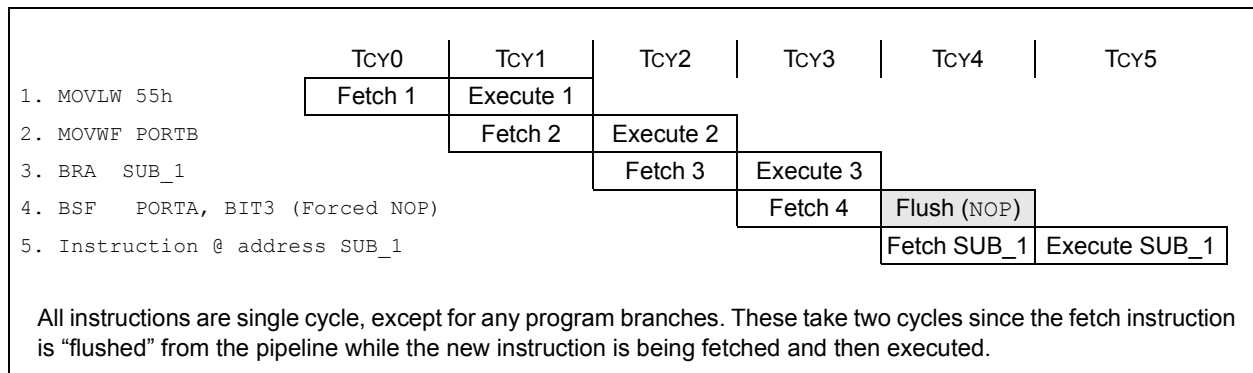
A fetch cycle begins with the Program Counter (PC) incrementing in Q1.

In the execution cycle, the fetched instruction is latched into the Instruction Register (IR) in cycle Q1. This instruction is then decoded and executed during the Q2, Q3 and Q4 cycles. Data memory is read during Q2 (operand read) and written during Q4 (destination write).

**FIGURE 3-3: CLOCK/INSTRUCTION CYCLE**



**EXAMPLE 3-3: INSTRUCTION PIPELINE FLOW**



# PIC18(L)F1XK22

## 3.2.3 INSTRUCTIONS IN PROGRAM MEMORY

The program memory is addressed in bytes. Instructions are stored as either two bytes or four bytes in program memory. The Least Significant Byte (LSB) of an instruction word is always stored in a program memory location with an even address (LSb = 0). To maintain alignment with instruction boundaries, the PC increments in steps of 2 and the LSb will always read '0' (see [Section 3.1.1 "Program Counter"](#)).

[Figure 3-4](#) shows an example of how instruction words are stored in the program memory.

The `CALL` and `GOTO` instructions have the absolute program memory address embedded into the instruction. Since instructions are always stored on word boundaries, the data contained in the instruction is a word address. The word address is written to PC<20:1>, which accesses the desired byte address in program memory. Instruction #2 in [Figure 3-4](#) shows how the instruction `GOTO 0006h` is encoded in the program memory. Program branch instructions, which encode a relative address offset, operate in the same manner. The offset value stored in a branch instruction represents the number of single-word instructions that the PC will be offset by. [Section 23.0 "Instruction Set Summary"](#) provides further details of the instruction set.

**FIGURE 3-4: INSTRUCTIONS IN PROGRAM MEMORY**

Program Memory Byte Locations →			Word Address	
			LSB = 1	LSB = 0
				000000h
				000002h
				000004h
				000006h
Instruction 1:	MOVLW	055h	0Fh	55h
Instruction 2:	GOTO	0006h	EFh	03h
			F0h	00h
			C1h	23h
Instruction 3:	MOVFF	123h, 456h	F4h	56h
				000010h
				000012h
				000014h

## 3.2.4 TWO-WORD INSTRUCTIONS

The standard PIC18 instruction set has four two-word instructions: `CALL`, `MOVFF`, `GOTO` and `LSFR`. In all cases, the second word of the instruction always has '1111' as its four Most Significant bits (MSb); the other 12 bits are literal data, usually a data memory address.

The use of '1111' in the 4 MSBs of an instruction specifies a special form of `NOE`. If the instruction is executed in proper sequence – immediately after the first word – the data in the second word is accessed

and used by the instruction sequence. If the first word is skipped for some reason and the second word is executed by itself, a `NOE` is executed instead. This is necessary for cases when the two-word instruction is preceded by a conditional instruction that changes the PC. [Example 3-4](#) shows how this works.

**Note:** See [Section 3.6 "PIC18 Instruction Execution and the Extended Instruction Set"](#) for information on two-word instructions in the extended instruction set.

**EXAMPLE 3-4: TWO-WORD INSTRUCTIONS**

CASE 1:			
Object Code	Source Code		
0110 0110 0000 0000	TSTFSZ	REG1	; is RAM location 0?
1100 0001 0010 0011	MOVFF	REG1, REG2	; No, skip this word
1111 0100 0101 0110			; Execute this word as a NOP
0010 0100 0000 0000	ADDWF	REG3	; continue code
CASE 2:			
Object Code	Source Code		
0110 0110 0000 0000	TSTFSZ	REG1	; is RAM location 0?
1100 0001 0010 0011	MOVFF	REG1, REG2	; Yes, execute this word
1111 0100 0101 0110			; 2nd word of instruction
0010 0100 0000 0000	ADDWF	REG3	; continue code

## 3.3 Data Memory Organization

**Note:** The operation of some aspects of data memory are changed when the PIC18 extended instruction set is enabled. See [Section 3.5 “Data Memory and the Extended Instruction Set”](#) for more information.

The data memory in PIC18 devices is implemented as static RAM. Each register in the data memory has a 12-bit address, allowing up to 4096 bytes of data memory. The memory space is divided into as many as 16 banks that contain 256 bytes each. [Figure 3-5](#) and [Figure 3-6](#) show the data memory organization for the PIC18(L)F1XK22 devices.

The data memory contains Special Function Registers (SFRs) and General Purpose Registers (GPRs). The SFRs are used for control and status of the controller and peripheral functions, while GPRs are used for data storage and scratchpad operations in the user's application. Any read of an unimplemented location will read as '0's.

The instruction set and architecture allow operations across all banks. The entire data memory may be accessed by Direct, Indirect or Indexed Addressing modes. Addressing modes are discussed later in this subsection.

To ensure that commonly used registers (SFRs and select GPRs) can be accessed in a single cycle, PIC18 devices implement an Access Bank. This is a 256-byte memory space that provides fast access to SFRs and the lower portion of GPR Bank 0 without using the Bank Select Register (BSR). [Section 3.3.2 “Access Bank”](#) provides a detailed description of the Access RAM.

### 3.3.1 BANK SELECT REGISTER (BSR)

Large areas of data memory require an efficient addressing scheme to make rapid access to any address possible. Ideally, this means that an entire address does not need to be provided for each read or write operation. For PIC18 devices, this is accomplished with a RAM banking scheme. This divides the memory space into 16 contiguous banks of 256 bytes. Depending on the instruction, each location can be addressed directly by its full 12-bit address, or an 8-bit low-order address and a 4-bit Bank Pointer.

Most instructions in the PIC18 instruction set make use of the Bank Pointer, known as the Bank Select Register (BSR). This SFR holds the 4 Most Significant bits of a location's address; the instruction itself includes the 8 Least Significant bits. Only the four lower bits of the BSR are implemented (BSR<3:0>). The upper four bits are unused; they will always read '0' and cannot be written to. The BSR can be loaded directly by using the `MOVLB` instruction.

The value of the BSR indicates the bank in data memory; the 8 bits in the instruction show the location in the bank and can be thought of as an offset from the bank's lower boundary. The relationship between the BSR's value and the bank division in data memory is shown in [Figure 3-5](#) and [Figure 3-6](#).

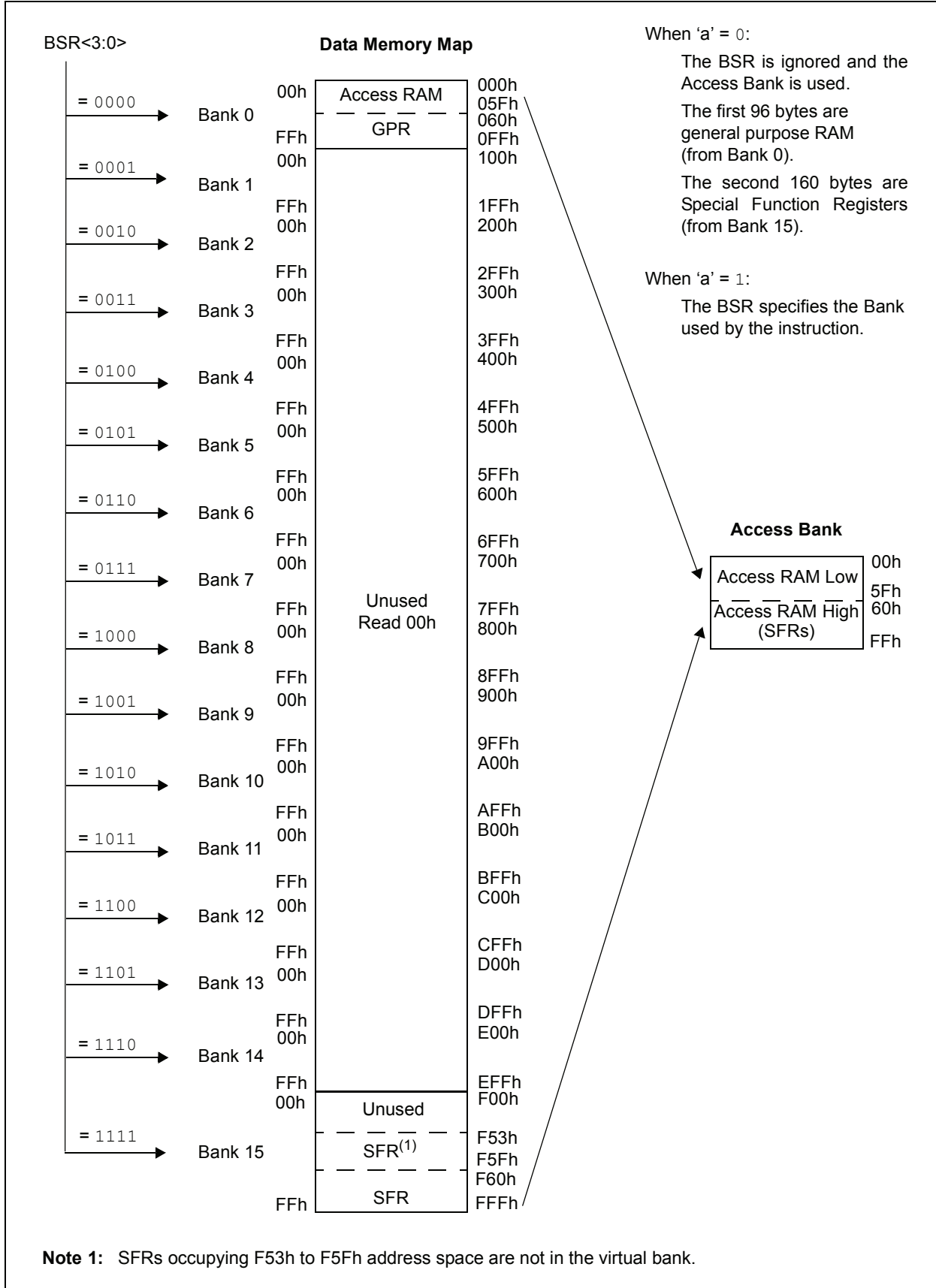
Since up to 16 registers may share the same low-order address, the user must always be careful to ensure that the proper bank is selected before performing a data read or write. For example, writing what should be program data to an 8-bit address of F9h while the BSR is 0Fh will end up resetting the program counter.

While any bank can be selected, only those banks that are actually implemented can be read or written to. Writes to unimplemented banks are ignored, while reads from unimplemented banks will return '0's. Even so, the STATUS register will still be affected as if the operation was successful. The data memory maps in [Figure 3-5](#) and [Figure 3-6](#) indicate which banks are implemented.

In the core PIC18 instruction set, only the `MOVFF` instruction fully specifies the 12-bit address of the source and target registers. This instruction ignores the BSR completely when it executes. All other instructions include only the low-order address as an operand and must use either the BSR or the Access Bank to locate their target registers.

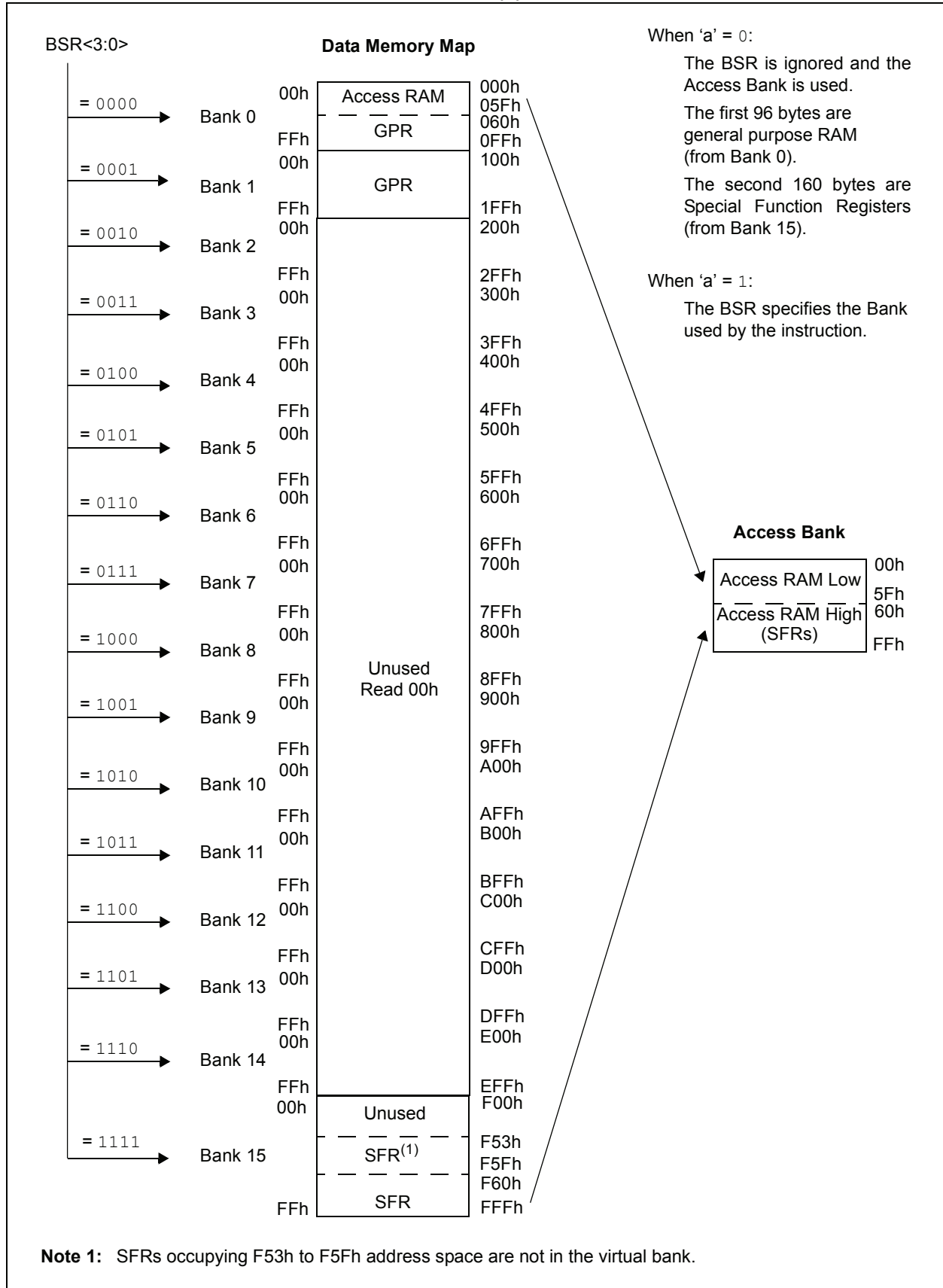
# PIC18(L)F1XK22

**FIGURE 3-5: DATA MEMORY MAP FOR PIC18(L)F13K22 DEVICES**



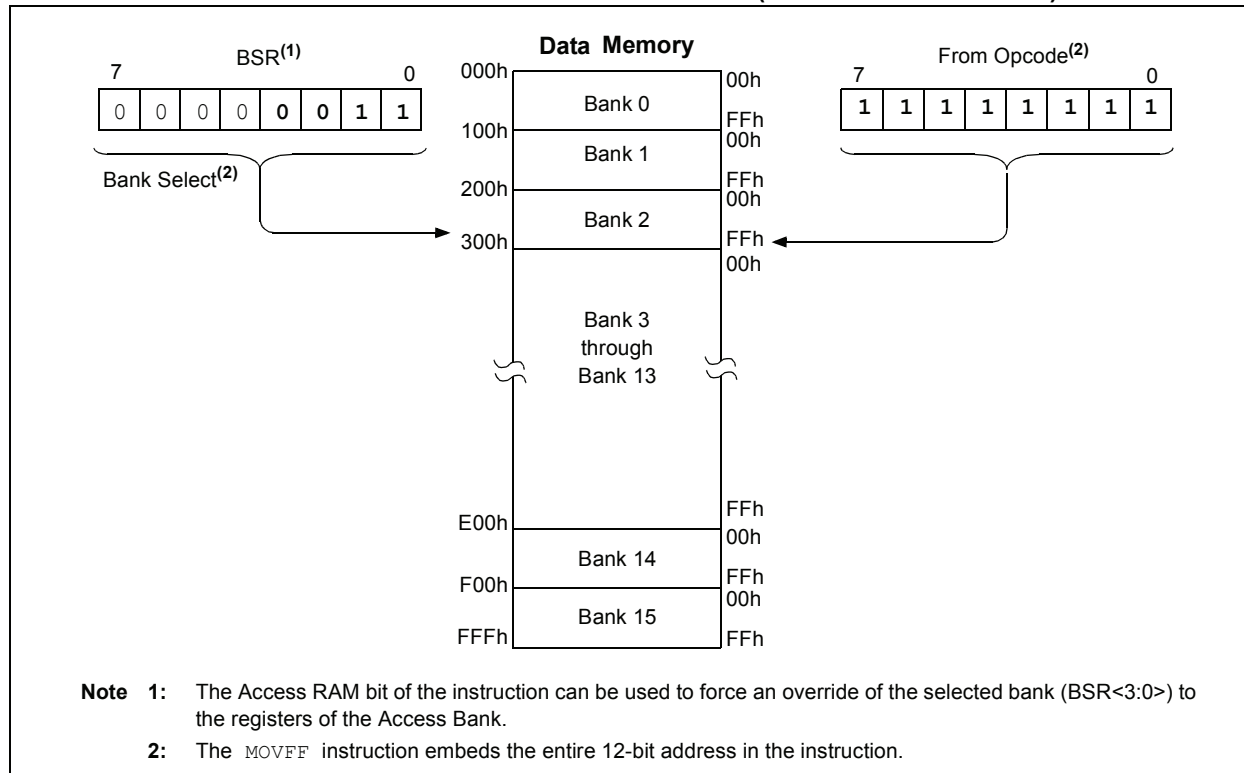


**FIGURE 3-6: DATA MEMORY MAP FOR PIC18(L)F14K22 DEVICES**



# PIC18(L)F1XK22

FIGURE 3-7: USE OF THE BANK SELECT REGISTER (DIRECT ADDRESSING)



## 3.3.2 ACCESS BANK

While the use of the BSR with an embedded 8-bit address allows users to address the entire range of data memory, it also means that the user must always ensure that the correct bank is selected. Otherwise, data may be read from or written to the wrong location. This can be disastrous if a GPR is the intended target of an operation, but an SFR is written to instead. Verifying and/or changing the BSR for each read or write to data memory can become very inefficient.

To streamline access for the most commonly used data memory locations, the data memory is configured with an Access Bank, which allows users to access a mapped block of memory without specifying a BSR. The Access Bank consists of the first 96 bytes of memory (00h-5Fh) in Bank 0 and the last 160 bytes of memory (60h-FFh) in Bank 15. The lower half is known as the “Access RAM” and is composed of GPRs. This upper half is also where the device’s SFRs are mapped. These two areas are mapped contiguously in the Access Bank and can be addressed in a linear fashion by an 8-bit address (Figure 3-5 and Figure 3-6).

The Access Bank is used by core PIC18 instructions that include the Access RAM bit (the ‘a’ parameter in the instruction). When ‘a’ is equal to ‘1’, the instruction uses the BSR and the 8-bit address included in the opcode for the data memory address. When ‘a’ is ‘0’, however, the instruction is forced to use the Access Bank address map; the current value of the BSR is ignored entirely.

Using this “forced” addressing allows the instruction to operate on a data address in a single cycle, without updating the BSR first. For 8-bit addresses of 60h and above, this means that users can evaluate and operate on SFRs more efficiently. The Access RAM below 60h is a good place for data values that the user might need to access rapidly, such as immediate computational results or common program variables. Access RAM also allows for faster and more code efficient context saving and switching of variables.

The mapping of the Access Bank is slightly different when the extended instruction set is enabled (XINST Configuration bit = 1). This is discussed in more detail in [Section 3.5.3 “Mapping the Access Bank in Indexed Literal Offset Mode”](#).

## 3.3.3 GENERAL PURPOSE REGISTER FILE

PIC18 devices may have banked memory in the GPR area. This is data RAM, which is available for use by all instructions. GPRs start at the bottom of Bank 0 (address 000h) and grow upwards towards the bottom of the SFR area. GPRs are not initialized by a Power-on Reset and are unchanged on all other Resets.

## 3.3.4 SPECIAL FUNCTION REGISTERS

The Special Function Registers (SFRs) are registers used by the CPU and peripheral modules for controlling the desired operation of the device. These registers are implemented as static RAM. SFRs start at the top of data memory (FFFh) and extend downward to occupy the top portion of Bank 15 (F60h to FFFh). A list of these registers is given in [Table 3-1](#) and [Table 3-2](#).

The SFRs can be classified into two sets: those associated with the “core” device functionality (ALU, Resets and interrupts) and those related to the peripheral functions. The Reset and Interrupt registers are described in their respective chapters, while the ALU’s STATUS register is described later in this section. Registers related to the operation of a peripheral feature are described in the chapter for that peripheral.

The SFRs are typically distributed among the peripherals whose functions they control. Unused SFR locations are unimplemented and read as ‘0’s.

# PIC18(L)F1XK22

**TABLE 3-1: SPECIAL FUNCTION REGISTER MAP FOR PIC18(L)F1XK22 DEVICES**

Address	Name	Address	Name	Address	Name	Address	Name	Address	Name
FFFh	TOSU	FD7h	TMR0H	FAFh	SPBRG	F87h	__ <sup>(2)</sup>	F5Fh	__ <sup>(2)</sup>
FFEh	TOSH	FD6h	TMR0L	FAEh	RCREG	F86h	__ <sup>(2)</sup>	F5Eh	__ <sup>(2)</sup>
FFDh	TOSL	FD5h	T0CON	FADh	TXREG	F85h	__ <sup>(2)</sup>	F5Dh	__ <sup>(2)</sup>
FFCh	STKPTR	FD4h	__ <sup>(2)</sup>	FACH	TXSTA	F84h	__ <sup>(2)</sup>	F5Ch	__ <sup>(2)</sup>
FFBh	PCLATU	FD3h	OSCCON	FABh	RCSTA	F83h	__ <sup>(2)</sup>	F5Bh	__ <sup>(2)</sup>
FFAh	PCLATH	FD2h	OSCCON2	FAAh	__ <sup>(2)</sup>	F82h	PORTC	F5Ah	__ <sup>(2)</sup>
FF9h	PCL	FD1h	WDTCON	FA9h	EEADR	F81h	PORTB	F59h	__ <sup>(2)</sup>
FF8h	TBLPTRU	FD0h	RCON	FA8h	EEDATA	F80h	PORTA	F58h	__ <sup>(2)</sup>
FF7h	TBLPTRH	FCFh	TMR1H	FA7h	EECON2 <sup>(1)</sup>	F7Fh	ANSELH	F57h	__ <sup>(2)</sup>
FF6h	TBLPTRL	FCEh	TMR1L	FA6h	EECON1	F7Eh	ANSEL	F56h	__ <sup>(2)</sup>
FF5h	TABLAT	FCDh	T1CON	FA5h	__ <sup>(2)</sup>	F7Dh	__ <sup>(2)</sup>	F55h	__ <sup>(2)</sup>
FF4h	PRODH	FCCCh	TMR2	FA4h	__ <sup>(2)</sup>	F7Ch	__ <sup>(2)</sup>	F54h	__ <sup>(2)</sup>
FF3h	PRODL	FCBh	PR2	FA3h	__ <sup>(2)</sup>	F7Bh	__ <sup>(2)</sup>	F53h	__ <sup>(2)</sup>
FF2h	INTCON	FCAh	T2CON	FA2h	IPR2	F7Ah	IOCB		
FF1h	INTCON2	FC9h	SSPBUF	FA1h	PIR2	F79h	IOCA		
FF0h	INTCON3	FC8h	SSPADD	FA0h	PIE2	F78h	WPUB		
FEFh	INDF0 <sup>(1)</sup>	FC7h	SSPSTAT	F9Fh	IPR1	F77h	WPUA		
FEeh	POSTINC0 <sup>(1)</sup>	FC6h	SSPCON1	F9Eh	PIR1	F76h	SLRCON		
FEDh	POSTDEC0 <sup>(1)</sup>	FC5h	SSPCON2	F9Dh	PIE1	F75h	__ <sup>(2)</sup>		
FECh	PREINC0 <sup>(1)</sup>	FC4h	ADRESH	F9Ch	__ <sup>(2)</sup>	F74h	__ <sup>(2)</sup>		
FEbh	PLUSW0 <sup>(1)</sup>	FC3h	ADRESL	F9Bh	OSCTUNE	F73h	__ <sup>(2)</sup>		
FEAh	FSR0H	FC2h	ADCON0	F9Ah	__ <sup>(2)</sup>	F72h	__ <sup>(2)</sup>		
FE9h	FSR0L	FC1h	ADCON1	F99h	__ <sup>(2)</sup>	F71h	__ <sup>(2)</sup>		
FE8h	WREG	FC0h	ADCON2	F98h	__ <sup>(2)</sup>	F70h	__ <sup>(2)</sup>		
FE7h	INDF1 <sup>(1)</sup>	FBFh	CCPR1H	F97h	__ <sup>(2)</sup>	F6Fh	SSPMASK		
FE6h	POSTINC1 <sup>(1)</sup>	FBEh	CCPR1L	F96h	__ <sup>(2)</sup>	F6Eh	__ <sup>(2)</sup>		
FE5h	POSTDEC1 <sup>(1)</sup>	FBDh	CCP1CON	F95h	__ <sup>(2)</sup>	F6Dh	CM1CON0		
FE4h	PREINC1 <sup>(1)</sup>	FBCh	VREFCON2	F94h	TRISC	F6Ch	CM2CON1		
FE3h	PLUSW1 <sup>(1)</sup>	FBBh	VREFCON1	F93h	TRISB	F6Bh	CM2CON0		
FE2h	FSR1H	FBAh	VREFCON0	F92h	TRISA	F6Ah	__ <sup>(2)</sup>		
FE1h	FSR1L	FB9h	PSTRCON	F91h	__ <sup>(2)</sup>	F69h	SRCON1		
FE0h	BSR	FB8h	BAUDCON	F90h	__ <sup>(2)</sup>	F68h	SRCON0		
FDfh	INDF2 <sup>(1)</sup>	FB7h	PWM1CON	F8Fh	__ <sup>(2)</sup>	F67h	__ <sup>(2)</sup>		
FDeh	POSTINC2 <sup>(1)</sup>	FB6h	ECCP1AS	F8Eh	__ <sup>(2)</sup>	F66h	__ <sup>(2)</sup>		
FDDh	POSTDEC2 <sup>(1)</sup>	FB5h	__ <sup>(2)</sup>	F8Dh	__ <sup>(2)</sup>	F65h	__ <sup>(2)</sup>		
FDCh	PREINC2 <sup>(1)</sup>	FB4h	__ <sup>(2)</sup>	F8Ch	__ <sup>(2)</sup>	F64h	__ <sup>(2)</sup>		
FDBh	PLUSW2 <sup>(1)</sup>	FB3h	TMR3H	F8Bh	LATC	F63h	__ <sup>(2)</sup>		
FDAh	FSR2H	FB2h	TMR3L	F8Ah	LATB	F62h	__ <sup>(2)</sup>		
FD9h	FSR2L	FB1h	T3CON	F89h	LATA	F61h	__ <sup>(2)</sup>		
FD8h	STATUS	FB0h	SPBRGH	F88h	__ <sup>(2)</sup>	F60h	__ <sup>(2)</sup>		

**Legend:**   = Unimplemented data memory locations, read as '0'.

**Note 1:** This is not a physical register.

**Note 2:** Unimplemented registers are read as '0'.

# PIC18(L)F1XK22

**TABLE 3-2: REGISTER FILE SUMMARY (PIC18(L)F1XK22)**

File Name	Bit 7	Bit 6	Bit 5	Bit 4	Bit 3	Bit 2	Bit 1	Bit 0	Value on POR, BOR	Details on page:
TOSU	—	—	—	Top-of-Stack Upper Byte (TOS<20:16>)					---0 0000	253, 26
TOSH	Top-of-Stack, High Byte (TOS<15:8>)								0000 0000	253, 26
TOSL	Top-of-Stack, Low Byte (TOS<7:0>)								0000 0000	253, 26
STKPTR	STKOVF	STKUNF	—	SP4	SP3	SP2	SP1	SP0	00-0 0000	253, 27
PCLATU	—	—	—	Holding Register for PC<20:16>					---0 0000	253, 26
PCLATH	Holding Register for PC<15:8>								0000 0000	253, 26
PCL	PC, Low Byte (PC<7:0>)								0000 0000	253, 26
TBLPTRU	—	—	—	Program Memory Table Pointer Upper Byte (TBLPTR<20:16>)					---0 0000	253, 50
TBLPTRH	Program Memory Table Pointer, High Byte (TBLPTR<15:8>)								0000 0000	253, 50
TBLPTRL	Program Memory Table Pointer, Low Byte (TBLPTR<7:0>)								0000 0000	253, 50
TABLAT	Program Memory Table Latch								0000 0000	253, 50
PRODH	Product Register, High Byte								xxxx xxxx	253, 61
PRODL	Product Register, Low Byte								xxxx xxxx	253, 61
INTCON	GIE/GIEH	PEIE/GIEL	TMR0IE	INT0IE	RABIE	TMR0IF	INT0IF	RABIF	0000 000x	253, 65
INTCON2	RABPU	INTEDG0	INTEDG1	INTEDG2	—	TMR0IP	—	RABIP	1111 -1-1	253, 66
INTCON3	INT2IP	INT1IP	—	INT2IE	INT1IE	—	INT2IF	INT1IF	11-0 0-00	253, 67
INDF0	Uses contents of FSR0 to address data memory – value of FSR0 not changed (not a physical register)								N/A	253, 42
POSTINC0	Uses contents of FSR0 to address data memory – value of FSR0 post-incremented (not a physical register)								N/A	253, 42
POSTDEC0	Uses contents of FSR0 to address data memory – value of FSR0 post-decremented (not a physical register)								N/A	253, 42
PREINC0	Uses contents of FSR0 to address data memory – value of FSR0 pre-incremented (not a physical register)								N/A	253, 42
PLUSW0	Uses contents of FSR0 to address data memory – value of FSR0 pre-incremented (not a physical register) – value of FSR0 offset by W								N/A	253, 42
FSR0H	—	—	—	—	Indirect Data Memory Address Pointer 0, High Byte				---- 0000	253, 42
FSR0L	Indirect Data Memory Address Pointer 0, Low Byte								xxxx xxxx	253, 42
WREG	Working Register								xxxx xxxx	253
INDF1	Uses contents of FSR1 to address data memory – value of FSR1 not changed (not a physical register)								N/A	253, 42
POSTINC1	Uses contents of FSR1 to address data memory – value of FSR1 post-incremented (not a physical register)								N/A	253, 42
POSTDEC1	Uses contents of FSR1 to address data memory – value of FSR1 post-decremented (not a physical register)								N/A	253, 42
PREINC1	Uses contents of FSR1 to address data memory – value of FSR1 pre-incremented (not a physical register)								N/A	253, 42
PLUSW1	Uses contents of FSR1 to address data memory – value of FSR1 pre-incremented (not a physical register) – value of FSR1 offset by W								N/A	253, 42
FSR1H	—	—	—	—	Indirect Data Memory Address Pointer 1, High Byte				---- 0000	254, 42
FSR1L	Indirect Data Memory Address Pointer 1, Low Byte								xxxx xxxx	254, 42
BSR	—	—	—	—	Bank Select Register				---- 0000	254, 31
INDF2	Uses contents of FSR2 to address data memory – value of FSR2 not changed (not a physical register)								N/A	254, 42
POSTINC2	Uses contents of FSR2 to address data memory – value of FSR2 post-incremented (not a physical register)								N/A	254, 42
POSTDEC2	Uses contents of FSR2 to address data memory – value of FSR2 post-decremented (not a physical register)								N/A	254, 42
PREINC2	Uses contents of FSR2 to address data memory – value of FSR2 pre-incremented (not a physical register)								N/A	254, 42
PLUSW2	Uses contents of FSR2 to address data memory – value of FSR2 pre-incremented (not a physical register) – value of FSR2 offset by W								N/A	254, 42
FSR2H	—	—	—	—	Indirect Data Memory Address Pointer 2, High Byte				---- 0000	254, 42
FSR2L	Indirect Data Memory Address Pointer 2, Low Byte								xxxx xxxx	254, 42
STATUS	—	—	—	N	OV	Z	DC	C	---x xxxx	254, 40

**Legend:** x = unknown, u = unchanged, – = unimplemented, q = value depends on condition

**Note 1:** The SBOREN bit is only available when the BOREN<1:0> Configuration bits = 01; otherwise it is disabled and reads as '0'. See [Section 21.4 "Brown-out Reset \(BOR\)"](#).

**2:** The RA3 bit is only available when Master Clear Reset is disabled (MCLR Configuration bit = 0). Otherwise, RA3 reads as '0'. This bit is read-only.

# PIC18(L)F1XK22

**TABLE 3-2: REGISTER FILE SUMMARY (PIC18(L)F1XK22) (CONTINUED)**

File Name	Bit 7	Bit 6	Bit 5	Bit 4	Bit 3	Bit 2	Bit 1	Bit 0	Value on POR, BOR	Details on page:
TMR0H	Timer0 Register, High Byte								0000 0000	254, 96
TMR0L	Timer0 Register, Low Byte								xxxx xxxx	254, 96
T0CON	TMR0ON	T08BIT	T0CS	T0SE	PSA	T0PS2	T0PS1	T0PS0	1111 1111	254, 95
OSCCON	IDLEN	IRCF2	IRCF1	IRCF0	OSTS	HFIOFS	SCS1	SCS0	0011 qq00	254, 18
OSCCON2	—	—	—	—	—	PRI_SD	HFIOFL	LFIOFS	---- -10x	254, 19
WDTCON	—	—	—	—	—	—	—	SWDTEN	--- ---0	254, 268
RCON	IPEN	SBOREN <sup>(1)</sup>	—	RI	TO	PD	POR	BOR	0q-1 11q0	245, 252, 65
TMR1H	Timer1 Register, High Byte								xxxx xxxx	254, 99
TMR1L	Timer1 Register, Low Bytes								xxxx xxxx	254, 99
T1CON	RD16	T1RUN	T1CKPS1	T1CKPS0	T1OSCEN	T1SYNC	TMR1CS	TMR1ON	0000 0000	254, 99
TMR2	Timer2 Register								0000 0000	254, 105
PR2	Timer2 Period Register								1111 1111	254, 105
T2CON	—	T2OUTPS3	T2OUTPS2	T2OUTPS1	T2OUTPS0	TMR2ON	T2CKPS1	T2CKPS0	-000 0000	254, 105
SSPBUF	SSP Receive Buffer/Transmit Register								xxxx xxxx	254, 134, 136
SSPADD	SSP Address Register in I <sup>2</sup> C™ Slave Mode. SSP Baud Rate Reload Register in I <sup>2</sup> C Master Mode.								0000 0000	254, 153
SSPSTAT	SMP	CKE	D/A	P	S	R/W	UA	BF	0000 0000	254, 134, 143
SSPCON1	WCOL	SSPOV	SSPEN	CKP	SSPM3	SSPM2	SSPM1	SSPM0	0000 0000	254, 134, 144
SSPCON2	GCEN	ACKSTAT	ACKDT	ACKEN	RCEN	PEN	RSEN	SEN	0000 0000	254, 145
ADRESH	A/D Result Register, High Byte								xxxx xxxx	255, 203
ADRESL	A/D Result Register, Low Byte								xxxx xxxx	255, 203
ADCON0	—	—	CHS3	CHS2	CHS1	CHS0	GO/DONE	ADON	--00 0000	255, 209
ADCON1	—	—	—	—	PVCFG1	PVCFG0	NVCFG1	NVCFG0	---- 0000	255, 210
ADCON2	ADFM	—	ACQT2	ACQT1	ACQT0	ADCS2	ADCS1	ADCS0	0-00 0000	255, 211
CCPR1H	Capture/Compare/PWM Register 1, High Byte								xxxx xxxx	255, 131
CCPR1L	Capture/Compare/PWM Register 1, Low Byte								xxxx xxxx	255, 131
CCP1CON	P1M1	P1M0	DC1B1	DC1B0	CCP1M3	CCP1M2	CCP1M1	CCP1M0	0000 0000	255, 111
VREFCON2	—	—	—	DAC1R4	DAC1R3	DAC1R2	DAC1R1	DAC1R0	---0 0000	255, 242
VREFCON1	D1EN	D1LPS	DAC1OE	---	D1PSS1	D1PSS0	—	D1NSS	000- 00-0	255, 242
VREFCON0	FVR1EN	FVR1ST	FVR1S1	FVR1S0	—	—	—	—	0001 ----	255, 241
PSTRCON	—	—	—	STRSYNC	STRD	STRC	STRB	STRA	---0 0001	255, 128
BAUDCON	ABDOVF	RCIDL	DTRXP	CKTXP	BRG16	—	WUE	ABDEN	0100 0-00	255, 186
PWM1CON	PRSEN	PDC6	PDC5	PDC4	PDC3	PDC2	PDC1	PDC0	0000 0000	255, 127
ECCP1AS	ECCPASE	ECCPAS2	ECCPAS1	ECCPAS0	PSSAC1	PSSAC0	PSSBD1	PSSBD0	0000 0000	255, 123
TMR3H	Timer3 Register, High Byte								xxxx xxxx	255, 107
TMR3L	Timer3 Register, Low Byte								xxxx xxxx	255, 107
T3CON	RD16	—	T3CKPS1	T3CKPS0	T3CCP1	T3SYNC	TMR3CS	TMR3ON	0-00 0000	255, 107

**Legend:** x = unknown, u = unchanged, - = unimplemented, q = value depends on condition

- Note 1:** The SBOREN bit is only available when the BOREN<1:0> Configuration bits = 01; otherwise it is disabled and reads as '0'. See [Section 21.4 "Brown-out Reset \(BOR\)"](#).
- 2:** The RA3 bit is only available when Master Clear Reset is disabled (MCLRE Configuration bit = 0). Otherwise, RA3 reads as '0'. This bit is read-only.

# PIC18(L)F1XK22

**TABLE 3-2: REGISTER FILE SUMMARY (PIC18(L)F1XK22) (CONTINUED)**

File Name	Bit 7	Bit 6	Bit 5	Bit 4	Bit 3	Bit 2	Bit 1	Bit 0	Value on POR, BOR	Details on page:
SPBRGH	EUSART Baud Rate Generator Register, High Byte								0000 0000	255, 187
SPBRG	EUSART Baud Rate Generator Register, Low Byte								0000 0000	255, 187
RCREG	EUSART Receive Register								0000 0000	255, 185
TXREG	EUSART Transmit Register								0000 0000	255, 184
TXSTA	CSRC	TX9	TXEN	SYNC	SENDB	BRGH	TRMT	TX9D	0000 0010	255, 184
RCSTA	SPEN	RX9	SREN	CREN	ADDEN	FERR	OERR	RX9D	0000 000x	255, 185
EEADR	EEADR7	EEADR6	EEADR5	EEADR4	EEADR3	EEADR2	EEADR1	EEADR0	0000 0000	255, 47, 57
EEDATA	EEPROM Data Register								0000 0000	255, 47, 57
EECON2	EEPROM Control Register 2 (not a physical register)								0000 0000	255, 47, 57
EECON1	EEPGD	CFGS	—	FREE	WRERR	WREN	WR	RD	xx-0 x000	255, 47, 57
IPR2	OSCFIP	C1IP	C2IP	EEIP	BCLIP	—	TMR3IP	—	1111 111-	256, 73
PIR2	OSCFIF	C1IF	C2IF	EEIF	BCLIF	—	TMR3IF	—	0000 000-	256, 69
PIE2	OSCFIE	C1IE	C2IE	EEIE	BCLIE	—	TMR3IE	—	0000 000-	256, 71
IPR1	—	ADIP	RCIP	TXIP	SSPIP	CCP1IP	TMR2IP	TMR1IP	-111 1111	256, 72
PIR1	—	ADIF	RCIF	TXIF	SSPIF	CCP1IF	TMR2IF	TMR1IF	-000 0000	256, 68
PIE1	—	ADIE	RCIE	TXIE	SSPIE	CCP1IE	TMR2IE	TMR1IE	-000 0000	256, 70
OSCTUNE	INTSRC	PLLEN	TUN5	TUN4	TUN3	TUN2	TUN1	TUN0	0000 0000	20, 256
TRISC	TRISC7	TRISC6	TRISC5	TRISC4	TRISC3	TRISC2	TRISC1	TRISC0	1111 1111	256, 88
TRISB	TRISB7	TRISB6	TRISB5	TRISB4	—	—	—	—	1111 ----	256, 84
TRISA	—	—	TRISA5	TRISA4	—	TRISA2	TRISA1	TRISA0	--11 -111	256, 79
LATC	LATC7	LATC6	LATC5	LATC4	LATC3	LATC2	LATC1	LATC0	xxxx xxxx	256, 89
LATB	LATB7	LATB6	LATB5	LATB4	—	—	—	—	xxxx ----	256, 85
LATA	—	—	LATA5	LATA4	—	LATA2	LATA1	LATA0	--xx -xxx	256, 80
PORTC	RC7	RC6	RC5	RC4	RC3	RC2	RC1	RC0	xxxx xxxx	256, 88
PORTB	RB7	RB6	RB5	RB4	—	—	—	—	xxxx ----	256, 84
PORTA	—	—	RA5	RA4	RA3 <sup>(2)</sup>	RA2	RA1	RA0	--xx xxxx	256, 79
ANSELH	—	—	—	—	ANS11	ANS10	ANS9	ANS8	---- 1111	256, 93
ANSEL	ANS7	ANS6	ANS5	ANS4	ANS3	ANS2	ANS1	ANS0	1111 1111	256, 92
IOCB	IOCB7	IOCB6	IOCB5	IOCB4	—	—	—	—	0000 ----	256, 85
IOCA	—	—	IOCA5	IOCA4	IOCA3	IOCA2	IOCA1	IOCA0	--00 0000	256, 80
WPUB	WPUB7	WPUB6	WPUB5	WPUB4	—	—	—	—	1111 ----	256, 85
WPUA	—	—	WPUA5	WPUA4	WPUA3	WPUA2	WPUA1	WPUA0	--11 1111	253, 80
SLRCON	—	—	—	—	—	SLRC	SLRB	SLRA	---- -111	256, 94
SSPMSK	MSK7	MSK6	MSK5	MSK4	MSK3	MSK2	MSK1	MSK0	1111 1111	256, 152
CM1CON0	C1ON	C1OUT	C1OE	C1POL	C1SP	C1R	C1CH1	C1CH0	0000 1000	256, 223
CM2CON1	MC1OUT	MC2OUT	C1RSEL	C2RSEL	C1HYS	C2HYS	C1SYNC	C2SYNC	0000 0000	256, 224
CM2CON0	C2ON	C2OUT	C2OE	C2POL	C2SP	C2R	C2CH1	C2CH0	0000 1000	256, 224
SRCON1	SRSPE	SRSCKE	SRSC2E	SRSC1E	SRRPE	SRRCKE	SRRC2E	SRRC1E	0000 0000	256, 237
SRCON0	SRLLEN	SRCLK2	SRCLK1	SRCLK0	SRQEN	SRNQEN	SRPS	SRPR	0000 0000	256, 236

**Legend:** x = unknown, u = unchanged, — = unimplemented, q = value depends on condition

**Note 1:** The SBOREN bit is only available when the BOREN<1:0> Configuration bits = 01; otherwise it is disabled and reads as '0'. See [Section 21.4 "Brown-out Reset \(BOR\)"](#).

**2:** The RA3 bit is only available when Master Clear Reset is disabled (MCLR Configuration bit = 0). Otherwise, RA3 reads as '0'. This bit is read-only.

# PIC18(L)F1XK22

## 3.3.5 STATUS REGISTER

The STATUS register, shown in [Register 3-2](#), contains the arithmetic status of the ALU. As with any other SFR, it can be the operand for any instruction.

If the STATUS register is the destination for an instruction that affects the Z, DC, C, OV or N bits, the results of the instruction are not written; instead, the STATUS register is updated according to the instruction performed. Therefore, the result of an instruction with the STATUS register as its destination may be different than intended. As an example, `CLRF STATUS` will set the Z bit and leave the remaining Status bits unchanged ('000u u1uu').

It is recommended that only `BCF`, `BSF`, `SWAPF`, `MOVFF` and `MOVWF` instructions are used to alter the STATUS register, because these instructions do not affect the Z, C, DC, OV or N bits in the STATUS register.

For other instructions that do not affect Status bits, see the instruction set summaries in [Table 23-2](#) and [Table 23-3](#).

**Note:** The C and DC bits operate as the borrow and digit borrow bits, respectively, in subtraction.

**REGISTER 3-2: STATUS: STATUS REGISTER**

U-0	U-0	U-0	R/W-x	R/W-x	R/W-x	R/W-x	R/W-x
—	—	—	N	OV	Z	DC <sup>(1)</sup>	C <sup>(1)</sup>
bit 7							bit 0

**Legend:**

R = Readable bit	W = Writable bit	U = Unimplemented bit, read as '0'
-n = Value at POR	'1' = Bit is set	'0' = Bit is cleared      x = Bit is unknown

- bit 7-5      **Unimplemented:** Read as '0'
- bit 4      **N:** Negative bit  
This bit is used for signed arithmetic (two's complement). It indicates whether the result was negative (ALU MSB = 1).  
1 = Result was negative  
0 = Result was positive
- bit 3      **OV:** Overflow bit  
This bit is used for signed arithmetic (two's complement). It indicates an overflow of the 7-bit magnitude which causes the sign bit (bit 7 of the result) to change state.  
1 = Overflow occurred for signed arithmetic (in this arithmetic operation)  
0 = No overflow occurred
- bit 2      **Z:** Zero bit  
1 = The result of an arithmetic or logic operation is zero  
0 = The result of an arithmetic or logic operation is not zero
- bit 1      **DC:** Digit Carry/Borrow bit (`ADDWF`, `ADDLW`, `SUBLW`, `SUBWF` instructions)<sup>(1)</sup>  
1 = A carry-out from the 4th low-order bit of the result occurred  
0 = No carry-out from the 4th low-order bit of the result
- bit 0      **C:** Carry/Borrow bit (`ADDWF`, `ADDLW`, `SUBLW`, `SUBWF` instructions)<sup>(1)</sup>  
1 = A carry-out from the Most Significant bit of the result occurred  
0 = No carry-out from the Most Significant bit of the result occurred

**Note 1:** For Borrow, the polarity is reversed. A subtraction is executed by adding the two's complement of the second operand. For rotate (`RRF`, `RLF`) instructions, this bit is loaded with either the high-order or low-order bit of the source register.



## 3.4 Data Addressing Modes

**Note:** The execution of some instructions in the core PIC18 instruction set are changed when the PIC18 extended instruction set is enabled. See [Section 3.5 “Data Memory and the Extended Instruction Set”](#) for more information.

While the program memory can be addressed in only one way – through the program counter – information in the data memory space can be addressed in several ways. For most instructions, the addressing mode is fixed. Other instructions may use up to three modes, depending on which operands are used and whether or not the extended instruction set is enabled.

The addressing modes are:

- Inherent
- Literal
- Direct
- Indirect

An additional addressing mode, Indexed Literal Offset, is available when the extended instruction set is enabled (XINST Configuration bit = 1). Its operation is discussed in greater detail in [Section 3.5.1 “Indexed Addressing with Literal Offset”](#).

### 3.4.1 INHERENT AND LITERAL ADDRESSING

Many PIC18 control instructions do not need any argument at all; they either perform an operation that globally affects the device or they operate implicitly on one register. This addressing mode is known as Inherent Addressing. Examples include `SLEEP`, `RESET` and `DAW`.

Other instructions work in a similar way but require an additional explicit argument in the opcode. This is known as Literal Addressing mode because they require some literal value as an argument. Examples include `ADDLW` and `MOVLW`, which respectively, add or move a literal value to the W register. Other examples include `CALL` and `GOTO`, which include a 20-bit program memory address.

### 3.4.2 DIRECT ADDRESSING

Direct addressing specifies all or part of the source and/or destination address of the operation within the opcode itself. The options are specified by the arguments accompanying the instruction.

In the core PIC18 instruction set, bit-oriented and byte-oriented instructions use some version of direct addressing by default. All of these instructions include some 8-bit literal address as their Least Significant Byte. This address specifies either a register address in one of the banks of data RAM ([Section 3.3.3 “General Purpose Register File”](#)) or a location in the Access Bank ([Section 3.3.2 “Access Bank”](#)) as the data source for the instruction.

The Access RAM bit ‘a’ determines how the address is interpreted. When ‘a’ is ‘1’, the contents of the BSR ([Section 3.3.1 “Bank Select Register \(BSR\)”](#)) are used with the address to determine the complete 12-bit address of the register. When ‘a’ is ‘0’, the address is interpreted as being a register in the Access Bank. Addressing that uses the Access RAM is sometimes also known as Direct Forced Addressing mode.

A few instructions, such as `MOVFF`, include the entire 12-bit address (either source or destination) in their opcodes. In these cases, the BSR is ignored entirely.

The destination of the operation’s results is determined by the destination bit ‘d’. When ‘d’ is ‘1’, the results are stored back in the source register, overwriting its original contents. When ‘d’ is ‘0’, the results are stored in the W register. Instructions without the ‘d’ argument have a destination that is implicit in the instruction; their destination is either the target register being operated on or the W register.

### 3.4.3 INDIRECT ADDRESSING

Indirect addressing allows the user to access a location in data memory without giving a fixed address in the instruction. This is done by using File Select Registers (FSRs) as pointers to the locations which are to be read or written. Since the FSRs are themselves located in RAM as Special File Registers, they can also be directly manipulated under program control. This makes FSRs very useful in implementing data structures, such as tables and arrays in data memory.

The registers for indirect addressing are also implemented with Indirect File Operands (INDFs) that permit automatic manipulation of the pointer value with auto-incrementing, auto-decrementing or offsetting with another value. This allows for efficient code, using loops, such as the example of clearing an entire RAM bank in [Example 3-5](#).

#### EXAMPLE 3-5: HOW TO CLEAR RAM (BANK 1) USING INDIRECT ADDRESSING

```

NEXT    LFSR    FSR0, 100h ;
        CLRF   POSTINC0 ; Clear INDF
        ; register then
        ; inc pointer
        BTFSS  FSR0H, 1  ; All done with
        ; Bank1?
        BRA    NEXT      ; NO, clear next
CONTINUE ; YES, continue
    
```

# PIC18(L)F1XK22

## 3.4.3.1 FSR Registers and the INDF Operand

At the core of indirect addressing are three sets of registers: FSR0, FSR1 and FSR2. Each represents a pair of 8-bit registers, FSRnH and FSRnL. Each FSR pair holds a 12-bit value, therefore the four upper bits of the FSRnH register are not used. The 12-bit FSR value can address the entire range of the data memory in a linear fashion. The FSR register pairs, then, serve as pointers to data memory locations.

Indirect addressing is accomplished with a set of Indirect File Operands, INDF0 through INDF2. These can be thought of as “virtual” registers: they are mapped in the SFR space but are not physically implemented. Reading or writing to a particular INDF register actually accesses its corresponding FSR register pair. A read from INDF1, for example, reads the data at the address indicated by FSR1H:FSR1L. Instructions that use the INDF registers as operands actually use the contents of their corresponding FSR as a pointer to the instruction’s target. The INDF operand is just a convenient way of using the pointer.

Because indirect addressing uses a full 12-bit address, data RAM banking is not necessary. Thus, the current contents of the BSR and the Access RAM bit have no effect on determining the target address.

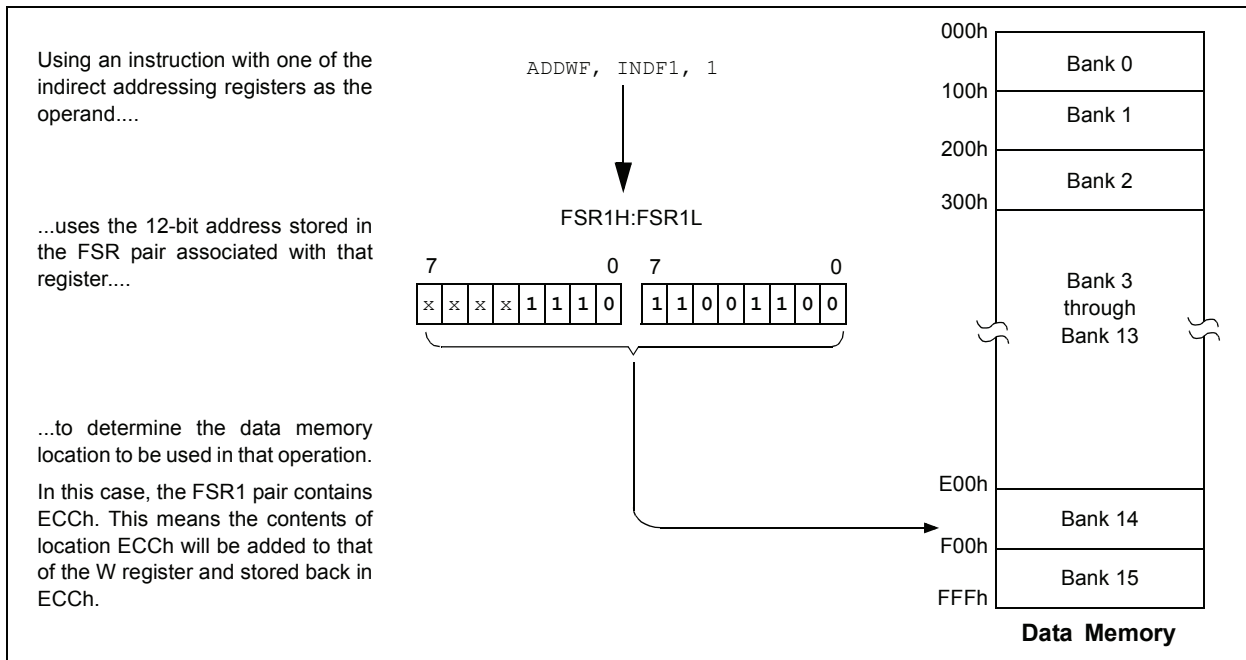
## 3.4.3.2 FSR Registers and POSTINC, POSTDEC, PREINC and PLUSW

In addition to the INDF operand, each FSR register pair also has four additional indirect operands. Like INDF, these are “virtual” registers which cannot be directly read or written. Accessing these registers actually accesses the location to which the associated FSR register pair points, and also performs a specific action on the FSR value. They are:

- POSTDEC: accesses the location to which the FSR points, then automatically decrements the FSR by 1 afterwards
- POSTINC: accesses the location to which the FSR points, then automatically increments the FSR by 1 afterwards
- PREINC: automatically increments the FSR by 1, then uses the location to which the FSR points in the operation
- PLUSW: adds the signed value of the W register (range of -127 to 128) to that of the FSR and uses the location to which the result points in the operation.

In this context, accessing an INDF register uses the value in the associated FSR register without changing it. Similarly, accessing a PLUSW register gives the FSR value an offset by that in the W register; however, neither W nor the FSR is actually changed in the operation. Accessing the other virtual registers changes the value of the FSR register.

**FIGURE 3-8: INDIRECT ADDRESSING**



Operations on the FSRs with POSTDEC, POSTINC and PREINC affect the entire register pair; that is, roll-overs of the FSRnL register from FFh to 00h carry over to the FSRnH register. On the other hand, results of these operations do not change the value of any flags in the STATUS register (e.g., Z, N, OV, etc.).

The PLUSW register can be used to implement a form of indexed addressing in the data memory space. By manipulating the value in the W register, users can reach addresses that are fixed offsets from pointer addresses. In some applications, this can be used to implement some powerful program control structure, such as software stacks, inside of data memory.

### 3.4.3.3 Operations by FSRs on FSRs

Indirect addressing operations that target other FSRs or virtual registers represent special cases. For example, using an FSR to point to one of the virtual registers will not result in successful operations. As a specific case, assume that FSR0H:FSR0L contains FE7h, the address of INDF1. Attempts to read the value of the INDF1 using INDF0 as an operand will return 00h. Attempts to write to INDF1 using INDF0 as the operand will result in a `NOOP`.

On the other hand, using the virtual registers to write to an FSR pair may not occur as planned. In these cases, the value will be written to the FSR pair but without any incrementing or decrementing. Thus, writing to either the INDF2 or POSTDEC2 register will write the same value to the FSR2H:FSR2L.

Since the FSRs are physical registers mapped in the SFR space, they can be manipulated through all direct operations. Users should proceed cautiously when working on these registers, particularly if their code uses indirect addressing.

Similarly, operations by indirect addressing are generally permitted on all other SFRs. Users should exercise the appropriate caution that they do not inadvertently change settings that might affect the operation of the device.

## 3.5 Data Memory and the Extended Instruction Set

Enabling the PIC18 extended instruction set (XINST Configuration bit = 1) significantly changes certain aspects of data memory and its addressing. Specifically, the use of the Access Bank for many of the core PIC18 instructions is different; this is due to the introduction of a new addressing mode for the data memory space.

What does not change is just as important. The size of the data memory space is unchanged, as well as its linear addressing. The SFR map remains the same. Core PIC18 instructions can still operate in both Direct and Indirect Addressing mode; inherent and literal instructions do not change at all. Indirect addressing with FSR0 and FSR1 also remain unchanged.

### 3.5.1 INDEXED ADDRESSING WITH LITERAL OFFSET

Enabling the PIC18 extended instruction set changes the behavior of indirect addressing using the FSR2 register pair within Access RAM. Under the proper conditions, instructions that use the Access Bank – that is, most bit-oriented and byte-oriented instructions – can invoke a form of indexed addressing using an offset specified in the instruction. This special addressing mode is known as Indexed Addressing with Literal Offset, or Indexed Literal Offset mode.

When using the extended instruction set, this addressing mode requires the following:

- The use of the Access Bank is forced ('a' = 0) and
- The file address argument is less than or equal to 5Fh.

Under these conditions, the file address of the instruction is not interpreted as the lower byte of an address (used with the BSR in direct addressing), or as an 8-bit address in the Access Bank. Instead, the value is interpreted as an offset value to an Address Pointer, specified by FSR2. The offset and the contents of FSR2 are added to obtain the target address of the operation.

### 3.5.2 INSTRUCTIONS AFFECTED BY INDEXED LITERAL OFFSET MODE

Any of the core PIC18 instructions that can use direct addressing are potentially affected by the Indexed Literal Offset Addressing mode. This includes all byte-oriented and bit-oriented instructions, or almost one-half of the standard PIC18 instruction set. Instructions that only use Inherent or Literal Addressing modes are unaffected.

Additionally, byte-oriented and bit-oriented instructions are not affected if they do not use the Access Bank (Access RAM bit is '1'), or include a file address of 60h or above. Instructions meeting these criteria will continue to execute as before. A comparison of the different possible addressing modes when the extended instruction set is enabled is shown in [Figure 3-9](#).

Those who desire to use byte-oriented or bit-oriented instructions in the Indexed Literal Offset mode should note the changes to assembler syntax for this mode. This is described in more detail in [Section 23.2.1 “Extended Instruction Syntax”](#).

# PIC18(L)F1XK22

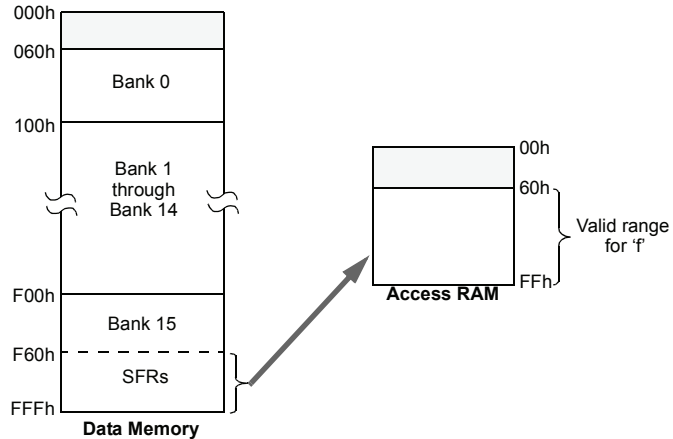
**FIGURE 3-9: COMPARING ADDRESSING OPTIONS FOR BIT-ORIENTED AND BYTE-ORIENTED INSTRUCTIONS (EXTENDED INSTRUCTION SET ENABLED)**

**EXAMPLE INSTRUCTION:** ADDWF, f, d, a (Opcode: 0010 01da ffff ffff)

**When 'a' = 0 and f ≥ 60h:**

The instruction executes in Direct Forced mode. 'f' is interpreted as a location in the Access RAM between 060h and 0FFh. This is the same as locations F60h to FFFh (Bank 15) of data memory.

Locations below 60h are not available in this addressing mode.



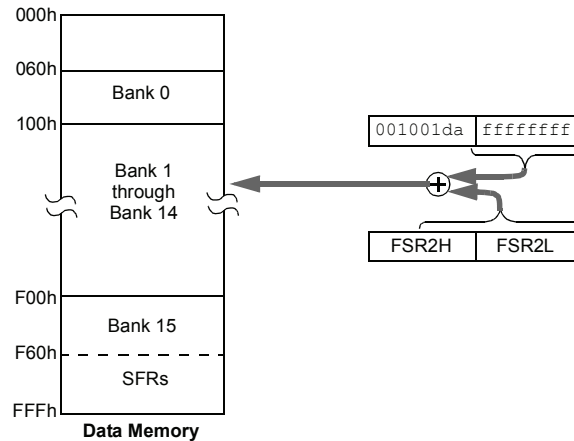
**When 'a' = 0 and f ≤ 5Fh:**

The instruction executes in Indexed Literal Offset mode. 'f' is interpreted as an offset to the address value in FSR2. The two are added together to obtain the address of the target register for the instruction. The address can be anywhere in the data memory space.

Note that in this mode, the correct syntax is now:

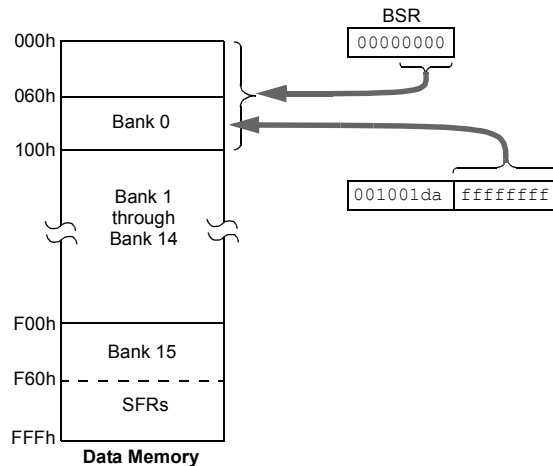
ADDWF [k], d

where 'k' is the same as 'f'.



**When 'a' = 1 (all values of f):**

The instruction executes in Direct mode (also known as Direct Long mode). 'f' is interpreted as a location in one of the 16 banks of the data memory space. The bank is designated by the Bank Select Register (BSR). The address can be in any implemented bank in the data memory space.



### 3.5.3 MAPPING THE ACCESS BANK IN INDEXED LITERAL OFFSET MODE

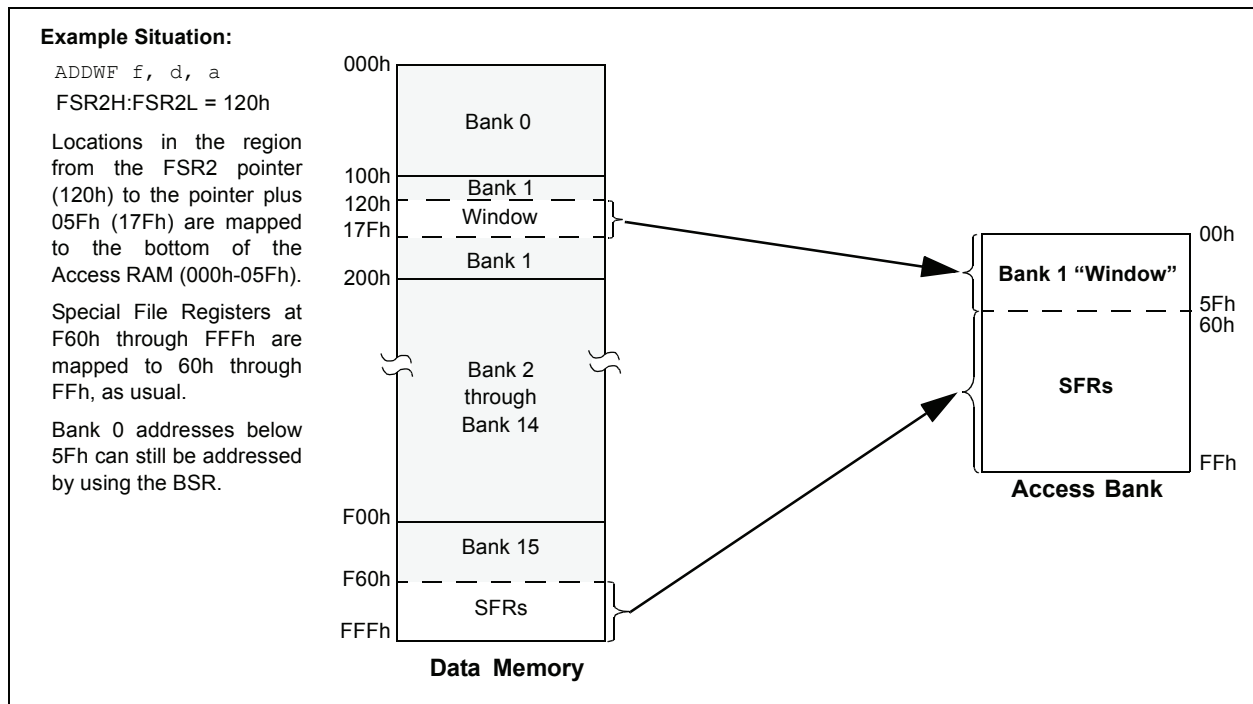
The use of Indexed Literal Offset Addressing mode effectively changes how the first 96 locations of Access RAM (00h to 5Fh) are mapped. Rather than containing just the contents of the bottom section of Bank 0, this mode maps the contents from a user defined “window” that can be located anywhere in the data memory space. The value of FSR2 establishes the lower boundary of the addresses mapped into the window, while the upper boundary is defined by FSR2 plus 95 (5Fh). Addresses in the Access RAM above 5Fh are mapped as previously described (see [Section 3.3.2 “Access Bank”](#)). An example of Access Bank remapping in this addressing mode is shown in [Figure 3-10](#).

Remapping of the Access Bank applies *only* to operations using the Indexed Literal Offset mode. Operations that use the BSR (Access RAM bit is ‘1’) will continue to use direct addressing as before.

### 3.6 PIC18 Instruction Execution and the Extended Instruction Set

Enabling the extended instruction set adds eight additional commands to the existing PIC18 instruction set. These instructions are executed as described in [Section 23.2 “Extended Instruction Set”](#).

**FIGURE 3-10: REMAPPING THE ACCESS BANK WITH INDEXED LITERAL OFFSET ADDRESSING**



# PIC18(L)F1XK22

---

NOTES:

## 4.0 FLASH PROGRAM MEMORY

The Flash program memory is readable, writable and erasable during normal operation over the entire VDD range.

A read from program memory is executed one byte at a time. A write to program memory is executed on blocks of 16 or 8 bytes at a time depending on the specific device (See Table 4-1). Program memory is erased in blocks of 64 bytes at a time. The difference between the write and erase block sizes requires from 4 to 8 block writes to restore the contents of a single block erase. A bulk erase operation can not be issued from user code.

**TABLE 4-1: WRITE/ERASE BLOCK SIZES**

Device	Write Block Size (bytes)	Erase Block Size (bytes)
PIC18(L)F13K22	8	64
PIC18(L)F14K22	16	64

Writing or erasing program memory will cease instruction fetches until the operation is complete. The program memory cannot be accessed during the write or erase, therefore, code cannot execute. An internal programming timer terminates program memory writes and erases.

A value written to program memory does not need to be a valid instruction. Executing a program memory location that forms an invalid instruction results in a NOP.

## 4.1 Table Reads and Table Writes

In order to read and write program memory, there are two operations that allow the processor to move bytes between the program memory space and the data RAM:

- Table Read (TBLRD)
- Table Write (TBLWT)

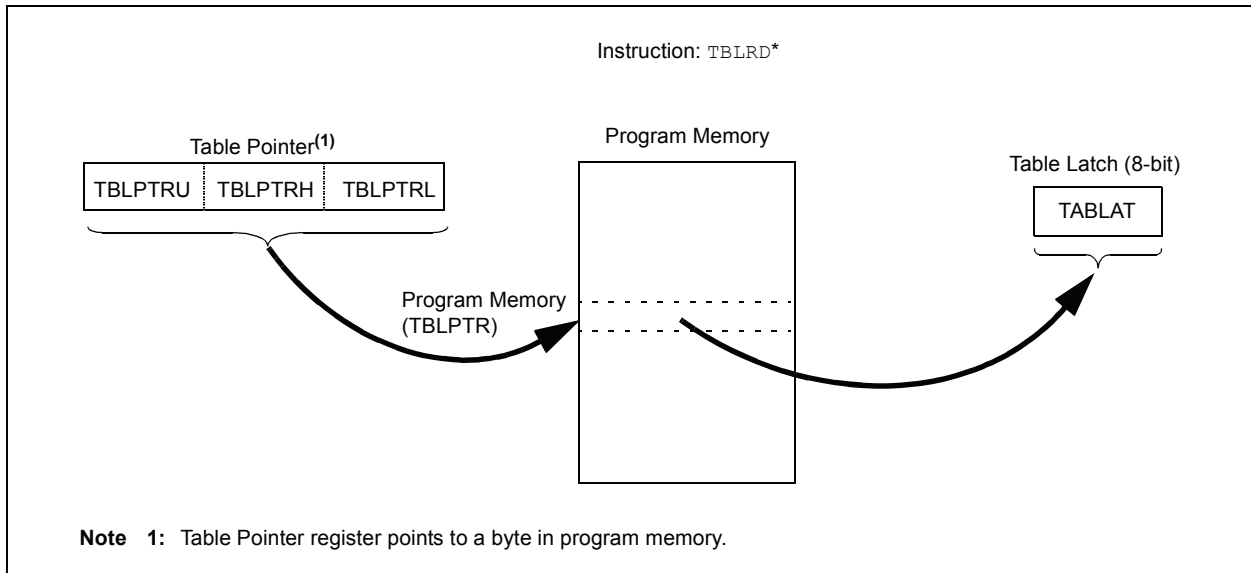
The program memory space is 16 bits wide, while the data RAM space is 8 bits wide. Table reads and table writes move data between these two memory spaces through an 8-bit register (TABLAT).

The table read operation retrieves one byte of data directly from program memory and places it into the TABLAT register. Figure 4-1 shows the operation of a table read.

The table write operation stores one byte of data from the TABLAT register into a write block holding register. The procedure to write the contents of the holding registers into program memory is detailed in Section 4.5 “Writing to Flash Program Memory”. Figure 4-2 shows the operation of a table write with program memory and data RAM.

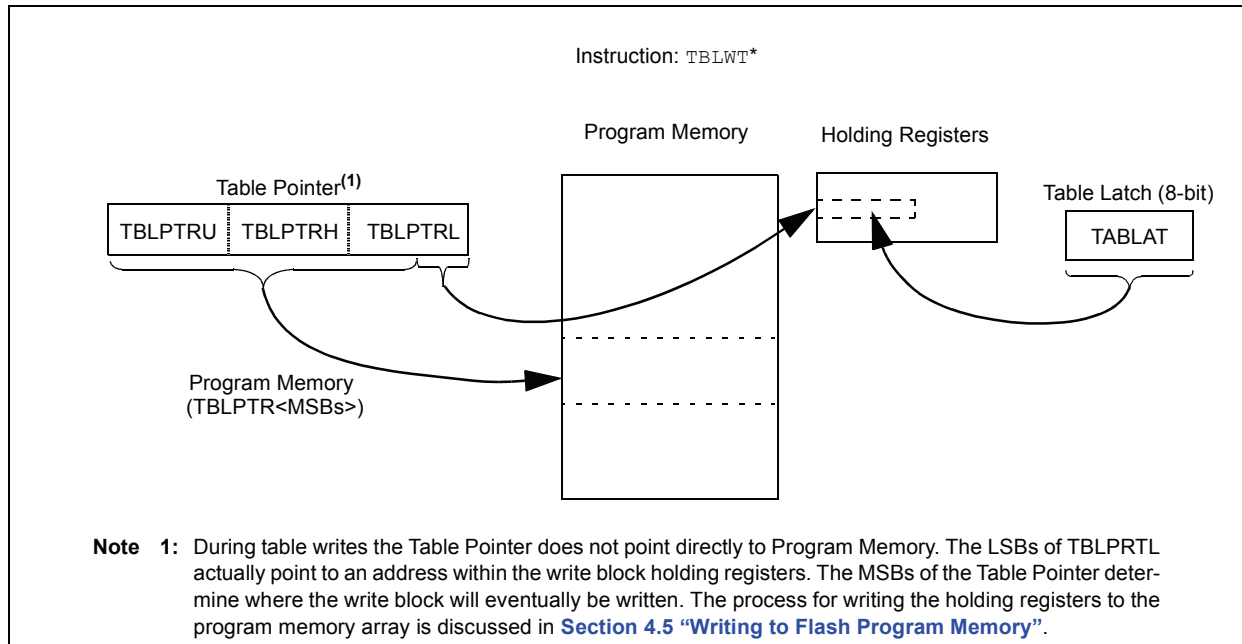
Table operations work with byte entities. Tables containing data, rather than program instructions, are not required to be word aligned. Therefore, a table can start and end at any byte address. If a table write is being used to write executable code into program memory, program instructions will need to be word aligned.

**FIGURE 4-1: TABLE READ OPERATION**



# PIC18(L)F1XK22

FIGURE 4-2: TABLE WRITE OPERATION



## 4.2 Control Registers

Several control registers are used in conjunction with the TBLRD and TBLWT instructions. These include the:

- EECON1 register
- EECON2 register
- TABLAT register
- TBLPTR registers

### 4.2.1 EECON1 AND EECON2 REGISTERS

The EECON1 register (Register 4-1) is the control register for memory accesses. The EECON2 register is not a physical register; it is used exclusively in the memory write and erase sequences. Reading EECON2 will read all ‘0’s.

The EEPGD control bit determines if the access will be a program or data EEPROM memory access. When EEPGD is clear, any subsequent operations will operate on the data EEPROM memory. When EEPGD is set, any subsequent operations will operate on the program memory.

The CFGS control bit determines if the access will be to the Configuration/Calibration registers or to program memory/data EEPROM memory. When CFGS is set, subsequent operations will operate on Configuration registers regardless of EEPGD (see Section 22.0 “Special Features of the CPU”). When CFGS is clear, memory selection access is determined by EEPGD.

The FREE bit allows the program memory erase operation. When FREE is set, an erase operation is initiated on the next WR command. When FREE is clear, only writes are enabled.

The WREN bit, when set, will allow a write operation. The WREN bit is clear on power-up.

The WRERR bit is set by hardware when the WR bit is set and cleared when the internal programming timer expires and the write operation is complete.

**Note:** During normal operation, the WRERR is read as ‘1’. This can indicate that a write operation was prematurely terminated by a Reset, or a write operation was attempted improperly.

The WR control bit initiates write operations. The WR bit cannot be cleared, only set, by firmware. Then WR bit is cleared by hardware at the completion of the write operation.

**Note:** The EEIF interrupt flag bit of the PIR2 register is set when the write is complete. The EEIF flag stays set until cleared by firmware.



## REGISTER 4-1: EECON1: DATA EEPROM CONTROL 1 REGISTER

R/W-x	R/W-x	U-0	R/W-0	R/W-x	R/W-0	R/S-0	R/S-0
EEPGD	CFGS	—	FREE	WRERR	WREN	WR	RD
bit 7							bit 0

### Legend:

R = Readable bit	W = Writable bit
S = Bit can be set by software, but not cleared	U = Unimplemented bit, read as '0'
-n = Value at POR	'1' = Bit is set
	'0' = Bit is cleared
	x = Bit is unknown

- bit 7      **EEPGD:** Flash Program or Data EEPROM Memory Select bit  
 1 = Access Flash program memory  
 0 = Access data EEPROM memory
- bit 6      **CFGS:** Flash Program/Data EEPROM or Configuration Select bit  
 1 = Access Configuration registers  
 0 = Access Flash program or data EEPROM memory
- bit 5      **Unimplemented:** Read as '0'
- bit 4      **FREE:** Flash Row (Block) Erase Enable bit  
 1 = Erase the program memory block addressed by TBLPTR on the next WR command  
 (cleared by completion of erase operation)  
 0 = Perform write-only
- bit 3      **WRERR:** Flash Program/Data EEPROM Error Flag bit<sup>(1)</sup>  
 1 = A write operation is prematurely terminated (any Reset during self-timed programming in normal  
 operation, or an improper write attempt)  
 0 = The write operation completed
- bit 2      **WREN:** Flash Program/Data EEPROM Write Enable bit  
 1 = Allows write cycles to Flash program/data EEPROM  
 0 = Inhibits write cycles to Flash program/data EEPROM
- bit 1      **WR:** Write Control bit  
 1 = Initiates a data EEPROM erase/write cycle or a program memory erase cycle or write cycle.  
 (The operation is self-timed and the bit is cleared by hardware once write is complete.  
 The WR bit can only be set (not cleared) by software.)  
 0 = Write cycle to the EEPROM is complete
- bit 0      **RD:** Read Control bit  
 1 = Initiates an EEPROM read (Read takes one cycle. RD is cleared by hardware. The RD bit can only  
 be set (not cleared) by software. RD bit cannot be set when EEGPD = 1 or CFGS = 1.)  
 0 = Does not initiate an EEPROM read

**Note 1:** When a WRERR occurs, the EEGPD and CFGS bits are not cleared. This allows tracing of the error condition.

# PIC18(L)F1XK22

## 4.2.2 TABLAT – TABLE LATCH REGISTER

The Table Latch (TABLAT) is an 8-bit register mapped into the SFR space. The Table Latch register is used to hold 8-bit data during data transfers between program memory and data RAM.

## 4.2.3 TBLPTR – TABLE POINTER REGISTER

The Table Pointer (TBLPTR) register addresses a byte within the program memory. The TBLPTR is comprised of three SFR registers: Table Pointer Upper Byte, Table Pointer High Byte and Table Pointer Low Byte (TBLPTRU:TBLPTRH:TBLPTRL). These three registers join to form a 22-bit wide pointer. The low-order 21 bits allow the device to address up to 2 Mbytes of program memory space. The 22nd bit allows access to the device ID, the user ID and the Configuration bits.

The Table Pointer register, TBLPTR, is used by the TBLRD and TBLWT instructions. These instructions can update the TBLPTR in one of four ways based on the table operation. These operations are shown in Table 4-2. These operations on the TBLPTR affect only the low-order 21 bits.

## 4.2.4 TABLE POINTER BOUNDARIES

TBLPTR is used in reads, writes and erases of the Flash program memory.

When a TBLRD is executed, all 22 bits of the TBLPTR determine which byte is read from program memory directly into the TABLAT register.

When a TBLWT is executed the byte in the TABLAT register is written, not to Flash memory but, to a holding register in preparation for a program memory write. The holding registers constitute a write block which varies depending on the device (See Table 4-1). The 3, 4, or 5 LSBs of the TBLPTRL register determine which specific address within the holding register block is written to. The MSBs of the Table Pointer have no effect during TBLWT operations.

When a program memory write is executed the entire holding register block is written to the Flash memory at the address determined by the MSBs of the TBLPTR. The 3, 4, or 5 LSBs are ignored during Flash memory writes. For more detail, see Section 4.5 “Writing to Flash Program Memory”.

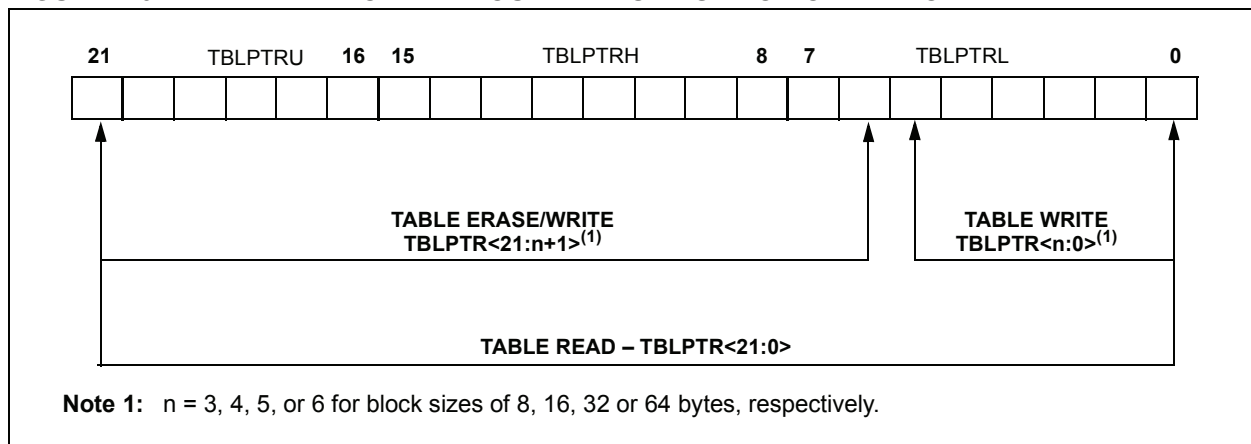
When an erase of program memory is executed, the 16 MSBs of the Table Pointer register (TBLPTR<21:6>) point to the 64-byte block that will be erased. The Least Significant bits (TBLPTR<5:0>) are ignored.

Figure 4-3 describes the relevant boundaries of TBLPTR based on Flash program memory operations.

**TABLE 4-2: TABLE POINTER OPERATIONS WITH TBLRD AND TBLWT INSTRUCTIONS**

Example	Operation on Table Pointer
TBLRD* TBLWT*	TBLPTR is not modified
TBLRD*+ TBLWT*+	TBLPTR is incremented after the read/write
TBLRD*- TBLWT*-	TBLPTR is decremented after the read/write
TBLRD+* TBLWT+*	TBLPTR is incremented before the read/write

**FIGURE 4-3: TABLE POINTER BOUNDARIES BASED ON OPERATION**



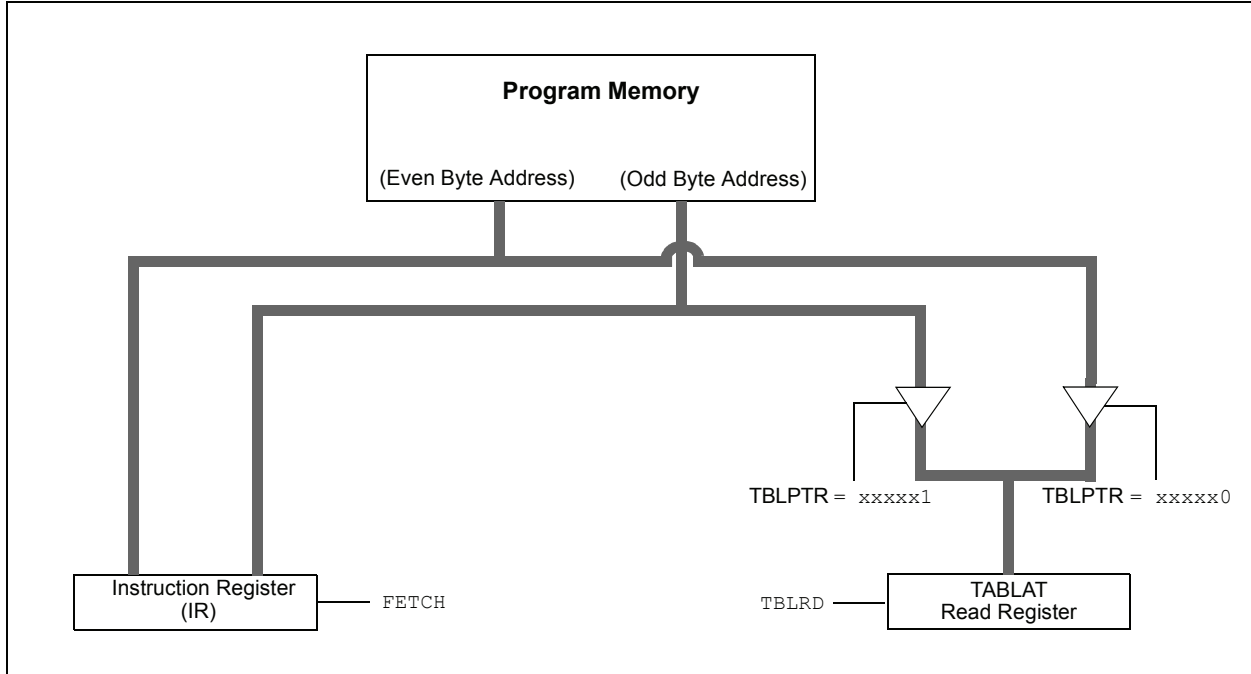
## 4.3 Reading the Flash Program Memory

The `TBLRD` instruction retrieves data from program memory and places it into data RAM. Table reads from program memory are performed one byte at a time.

`TBLPTR` points to a byte address in program space. Executing `TBLRD` places the byte pointed to into `TABLAT`. In addition, `TBLPTR` can be modified automatically for the next table read operation.

The internal program memory is typically organized by words. The Least Significant bit of the address selects between the high and low bytes of the word. Figure 4-4 shows the interface between the internal program memory and the `TABLAT`.

**FIGURE 4-4: READS FROM FLASH PROGRAM MEMORY**



**EXAMPLE 4-1: READING A FLASH PROGRAM MEMORY WORD**

```

        MOVLW    CODE_ADDR_UPPER    ; Load TBLPTR with the base
        MOVWF   TBLPTRU             ; address of the word
        MOVLW    CODE_ADDR_HIGH
        MOVWF   TBLPTRH
        MOVLW    CODE_ADDR_LOW
        MOVWF   TBLPTRL
READ_WORD
        TBLRD*+                       ; read into TABLAT and increment
        MOVF    TABLAT, W            ; get data
        MOVWF   WORD_EVEN
        TBLRD*+                       ; read into TABLAT and increment
        MOVFW   TABLAT, W            ; get data
        MOVF    WORD_ODD
    
```

# PIC18(L)F1XK22

## 4.4 Erasing Flash Program Memory

The minimum erase block is 32 words or 64 bytes. Only through the use of an external programmer, or through ICSP™ control, can larger blocks of program memory be bulk erased. Word erase in the Flash array is not supported.

When initiating an erase sequence from the Microcontroller itself, a block of 64 bytes of program memory is erased. The Most Significant 16 bits of the TBLPTR<21:6> point to the block being erased. The TBLPTR<5:0> bits are ignored.

The EECON1 register commands the erase operation. The EEPGD bit must be set to point to the Flash program memory. The WREN bit must be set to enable write operations. The FREE bit is set to select an erase operation.

The write initiate sequence for EECON2, shown as steps 4 through 6 in [Section 4.4.1 “Flash Program Memory Erase Sequence”](#), is used to guard against accidental writes. This is sometimes referred to as a long write.

A long write is necessary for erasing the internal Flash. Instruction execution is halted during the long write cycle. The long write is terminated by the internal programming timer.

### 4.4.1 FLASH PROGRAM MEMORY ERASE SEQUENCE

The sequence of events for erasing a block of internal program memory is:

1. Load Table Pointer register with address of block being erased.
2. Set the EECON1 register for the erase operation:
  - set EEPGD bit to point to program memory;
  - clear the CFGS bit to access program memory;
  - set WREN bit to enable writes;
  - set FREE bit to enable the erase.
3. Disable interrupts.
4. Write 55h to EECON2.
5. Write 0AAh to EECON2.
6. Set the WR bit. This will begin the block erase cycle.
7. The CPU will stall for duration of the erase (about 2 ms using internal timer).
8. Re-enable interrupts.

#### EXAMPLE 4-2: ERASING A FLASH PROGRAM MEMORY BLOCK

	MOVLW	CODE_ADDR_UPPER	; load TBLPTR with the base
	MOVWF	TBLPTRU	; address of the memory block
	MOVLW	CODE_ADDR_HIGH	
	MOVWF	TBLPTRH	
	MOVLW	CODE_ADDR_LOW	
	MOVWF	TBLPTRL	
ERASE_BLOCK			
	BSF	EECON1, EEPGD	; point to Flash program memory
	BCF	EECON1, CFGS	; access Flash program memory
	BSF	EECON1, WREN	; enable write to memory
	BSF	EECON1, FREE	; enable block Erase operation
	BCF	INTCON, GIE	; disable interrupts
<b>Required Sequence</b>	MOVLW	55h	
	MOVWF	EECON2	; write 55h
	MOVLW	0AAh	
	MOVWF	EECON2	; write 0AAh
	BSF	EECON1, WR	; start erase (CPU stall)
	BSF	INTCON, GIE	; re-enable interrupts

## 4.5 Writing to Flash Program Memory

The programming block size is 8 or 16 bytes, depending on the device (See [Table 4-1](#)). Word or byte programming is not supported.

Table writes are used internally to load the holding registers needed to program the Flash memory. There are only as many holding registers as there are bytes in a write block (See [Table 4-1](#)).

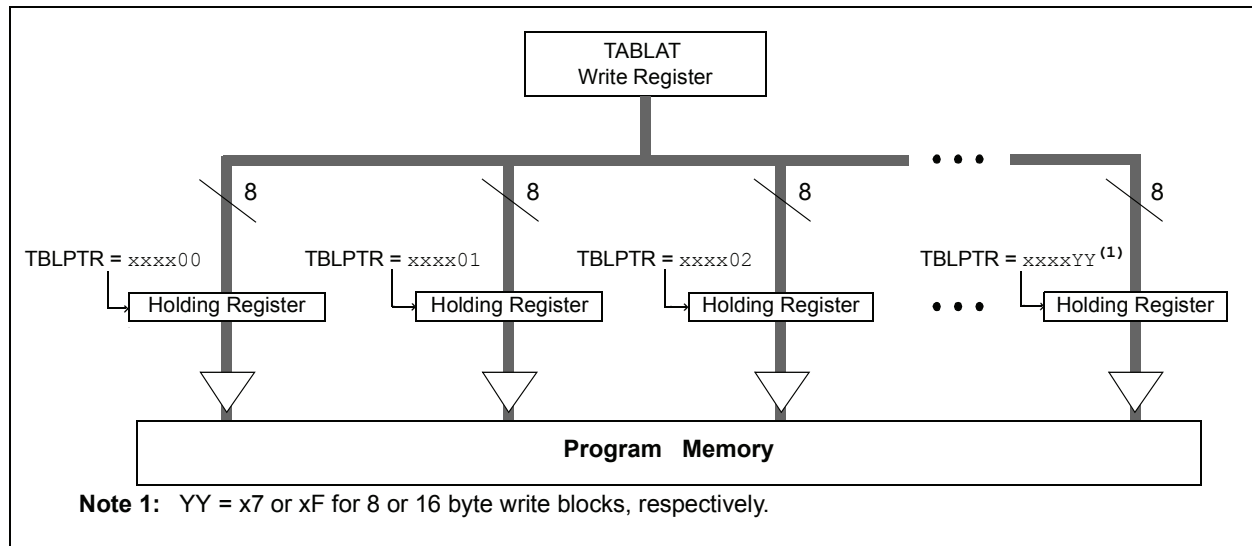
Since the Table Latch (TABLAT) is only a single byte, the `TBLWT` instruction may need to be executed 8, or 16 times, depending on the device, for each programming operation. All of the table write operations will essentially be short writes because only the holding registers are written. After all the holding registers have been written, the programming operation of that block of memory is started by configuring the `EECON1` register for a program memory write and performing the long write sequence.

The long write is necessary for programming the internal Flash. Instruction execution is halted during a long write cycle. The long write will be terminated by the internal programming timer.

The EEPROM on-chip timer controls the write time. The write/erase voltages are generated by an on-chip charge pump, rated to operate over the voltage range of the device.

**Note:** The default value of the holding registers on device Resets and after write operations is FFh. A write of FFh to a holding register does not modify that byte. This means that individual bytes of program memory may be modified, provided that the change does not attempt to change any bit from a '0' to a '1'. When modifying individual bytes, it is not necessary to load all holding registers before executing a long write operation.

**FIGURE 4-5: TABLE WRITES TO FLASH PROGRAM MEMORY**



### 4.5.1 FLASH PROGRAM MEMORY WRITE SEQUENCE

The sequence of events for programming an internal program memory location should be:

1. Read 64 bytes into RAM.
2. Update data values in RAM as necessary.
3. Load Table Pointer register with address being erased.
4. Execute the block erase procedure.
5. Load Table Pointer register with address of first byte being written.
6. Write the 8 or 16 byte block into the holding registers with auto-increment.
7. Set the `EECON1` register for the write operation:
  - set `EEPGD` bit to point to program memory;
  - clear the `CFGFS` bit to access program memory;
  - set `WREN` to enable byte writes.
8. Disable interrupts.
9. Write 55h to `EECON2`.
10. Write 0AAh to `EECON2`.
11. Set the `WR` bit. This will begin the write cycle.
12. The CPU will stall for duration of the write (about 2 ms using internal timer).
13. Re-enable interrupts.
14. Repeat steps 6 to 13 for each block until all 64 bytes are written.
15. Verify the memory (table read).

This procedure will require about 6 ms to update each write block of memory. An example of the required code is given in [Example 4-3](#).

**Note:** Before setting the `WR` bit, the Table Pointer address needs to be within the intended address range of the bytes in the holding registers.

# PIC18(L)F1XK22

## EXAMPLE 4-3: WRITING TO FLASH PROGRAM MEMORY

```

        MOVLW    D'64'                ; number of bytes in erase block
        MOVWF   COUNTER
        MOVLW   BUFFER_ADDR_HIGH     ; point to buffer
        MOVWF   FSR0H
        MOVLW   BUFFER_ADDR_LOW
        MOVWF   FSR0L
        MOVLW   CODE_ADDR_UPPER      ; Load TBLPTR with the base
        MOVWF   TBLPTRU              ; address of the memory block
        MOVLW   CODE_ADDR_HIGH
        MOVWF   TBLPTRH
        MOVLW   CODE_ADDR_LOW
        MOVWF   TBLPTRL

READ_BLOCK
        TBLRD*+                       ; read into TABLAT, and inc
        MOVF    TABLAT, W             ; get data
        MOVWF   POSTINC0             ; store data
        DECFSZ  COUNTER              ; done?
        BRA     READ_BLOCK           ; repeat

MODIFY_WORD
        MOVLW   BUFFER_ADDR_HIGH     ; point to buffer
        MOVWF   FSR0H
        MOVLW   BUFFER_ADDR_LOW
        MOVWF   FSR0L
        MOVLW   NEW_DATA_LOW        ; update buffer word
        MOVWF   POSTINC0
        MOVLW   NEW_DATA_HIGH
        MOVWF   INDF0

ERASE_BLOCK
        MOVLW   CODE_ADDR_UPPER      ; load TBLPTR with the base
        MOVWF   TBLPTRU              ; address of the memory block
        MOVLW   CODE_ADDR_HIGH
        MOVWF   TBLPTRH
        MOVLW   CODE_ADDR_LOW
        MOVWF   TBLPTRL
        BSF     EECON1, EEPGD        ; point to Flash program memory
        BCF     EECON1, CFGS        ; access Flash program memory
        BSF     EECON1, WREN        ; enable write to memory
        BSF     EECON1, FREE        ; enable Erase operation
        BCF     INTCON, GIE         ; disable interrupts

        MOVLW   55h
        MOVWF   EECON2              ; write 55h
        MOVLW   0AAh
        MOVWF   EECON2              ; write 0AAh
        BSF     EECON1, WR          ; start erase (CPU stall)
        BSF     INTCON, GIE         ; re-enable interrupts
        TBLRD*-                       ; dummy read decrement
        MOVLW   BUFFER_ADDR_HIGH     ; point to buffer
        MOVWF   FSR0H
        MOVLW   BUFFER_ADDR_LOW
        MOVWF   FSR0L

WRITE_BUFFER_BACK
        MOVLW   BlockSize            ; number of bytes in holding register
        MOVWF   COUNTER
        MOVLW   D'64'/BlockSize     ; number of write blocks in 64 bytes
        MOVWF   COUNTER2

WRITE_BYTE_TO_HREGS
        MOVF    POSTINC0, W         ; get low byte of buffer data
        MOVWF   TABLAT             ; present data to table latch
        TBLWT*+                     ; write data, perform a short write
        ; to internal TBLWT holding register.

```

## EXAMPLE 4-3: WRITING TO FLASH PROGRAM MEMORY (CONTINUED)

	DECFSZ	COUNTER		; loop until holding registers are full
	BRA	WRITE_WORD_TO_HREGS		
PROGRAM_MEMORY	BSF	EECON1, EEPGD		; point to Flash program memory
	BCF	EECON1, CFGS		; access Flash program memory
	BSF	EECON1, WREN		; enable write to memory
	BCF	INTCON, GIE		; disable interrupts
	MOVLW	55h		
<b>Required Sequence</b>	MOVWF	EECON2		; write 55h
	MOVLW	0AAh		
	MOVWF	EECON2		; write 0AAh
	BSF	EECON1, WR		; start program (CPU stall)
	DCFSZ	COUNTER2		; repeat for remaining write blocks
	BRA	WRITE_BYTE_TO_HREGS		
	BSF	INTCON, GIE		; re-enable interrupts
	BCF	EECON1, WREN		; disable write to memory

### 4.5.2 WRITE VERIFY

Depending on the application, good programming practice may dictate that the value written to the memory should be verified against the original value. This should be used in applications where excessive writes can stress bits near the specification limit.

### 4.5.3 UNEXPECTED TERMINATION OF WRITE OPERATION

If a write is terminated by an unplanned event, such as loss of power or an unexpected Reset, the memory location just programmed should be verified and reprogrammed if needed. If the write operation is interrupted by a  $\overline{\text{MCLR}}$  Reset or a WDT Time-out Reset during normal operation, the WRERR bit will be set which the user can check to decide whether a rewrite of the location(s) is needed.

### 4.5.4 PROTECTION AGAINST SPURIOUS WRITES

To protect against spurious writes to Flash program memory, the write initiate sequence must also be followed. See [Section 22.0 “Special Features of the CPU”](#) for more detail.

## 4.6 Flash Program Operation During Code Protection

See [Section 22.3 “Program Verification and Code Protection”](#) for details on code protection of Flash program memory.

**TABLE 4-3: REGISTERS ASSOCIATED WITH PROGRAM FLASH MEMORY**

Name	Bit 7	Bit 6	Bit 5	Bit 4	Bit 3	Bit 2	Bit 1	Bit 0	Reset Values on page
EECON1	EEPGD	CFGFS	—	FREE	WRERR	WREN	WR	RD	255
EECON2	EEPROM Control Register 2 (not a physical register)								255
INTCON	GIE/GIEH	PEIE/GIEL	TMR0IE	INT0IE	RABIE	TMR0IF	INT0IF	RABIF	253
IPR2	OSCFIP	C1IP	C2IP	EEIP	BCLIP	—	TMR3IP	—	256
PIE2	OSCFIE	C1IE	C2IE	EEIE	BCLIE	—	TMR3IE	—	256
PIR2	OSCFIF	C1IF	C2IF	EEIF	BCLIF	—	TMR3IF	—	256
TABLAT	Program Memory Table Latch								253
TBLPTRL	Program Memory Table Pointer Low Byte (TBLPTR<7:0>)								253
TBLPTRU	—	—	bit 21	Program Memory Table Pointer Upper Byte (TBLPTR<20:16>)					253
TBPLTRH	Program Memory Table Pointer High Byte (TBLPTR<15:8>)								253

**Legend:** — = unimplemented, read as ‘0’. Shaded cells are not used during Flash/EEPROM access.

# PIC18(L)F1XK22

---

NOTES:



## 5.0 DATA EEPROM MEMORY

The data EEPROM is a nonvolatile memory array, separate from the data RAM and program memory, which is used for long-term storage of program data. It is not directly mapped in either the register file or program memory space but is indirectly addressed through the Special Function Registers (SFRs). The EEPROM is readable and writable during normal operation over the entire VDD range.

Four SFRs are used to read and write to the data EEPROM as well as the program memory. They are:

- EECON1
- EECON2
- EEDATA
- EEADR

The data EEPROM allows byte read and write. When interfacing to the data memory block, EEDATA holds the 8-bit data for read/write and the EEADR register holds the address of the EEPROM location being accessed.

The EEPROM data memory is rated for high erase/write cycle endurance. A byte write automatically erases the location and writes the new data (erase-before-write). The write time is controlled by an on-chip timer; it will vary with voltage and temperature as well as from chip-to-chip. Please refer to parameter US122 (Table 25-13 in Section 25.0 “Electrical Specifications”) for exact limits.

### 5.1 EEADR Register

The EEADR register is used to address the data EEPROM for read and write operations. The 8-bit range of the register can address a memory range of 256 bytes (00h to FFh).

### 5.2 EECON1 and EECON2 Registers

Access to the data EEPROM is controlled by two registers: EECON1 and EECON2. These are the same registers which control access to the program memory and are used in a similar manner for the data EEPROM.

The EECON1 register (Register 5-1) is the control register for data and program memory access. Control bit EEPGD determines if the access will be to program or data EEPROM memory. When the EEPGD bit is clear, operations will access the data EEPROM memory. When the EEPGD bit is set, program memory is accessed.

Control bit, CFGS, determines if the access will be to the Configuration registers or to program memory/data EEPROM memory. When the CFGS bit is set, subsequent operations access Configuration registers. When the CFGS bit is clear, the EEPGD bit selects either program Flash or data EEPROM memory.

The WREN bit, when set, will allow a write operation. On power-up, the WREN bit is clear.

The WRERR bit is set by hardware when the WR bit is set and cleared when the internal programming timer expires and the write operation is complete.

**Note:** During normal operation, the WRERR may read as ‘1’. This can indicate that a write operation was prematurely terminated by a Reset, or a write operation was attempted improperly.

The WR control bit initiates write operations. The bit can be set but not cleared by software. It is cleared only by hardware at the completion of the write operation.

**Note:** The EEIF interrupt flag bit of the PIR2 register is set when the write is complete. It must be cleared by software.

Control bits, RD and WR, start read and erase/write operations, respectively. These bits are set by firmware and cleared by hardware at the completion of the operation.

The RD bit cannot be set when accessing program memory (EEPGD = 1). Program memory is read using table read instructions. See Section 4.1 “Table Reads and Table Writes” regarding table reads.

The EECON2 register is not a physical register. It is used exclusively in the memory write and erase sequences. Reading EECON2 will read all ‘0’s.

# PIC18(L)F1XK22

## REGISTER 5-1: EECON1: DATA EEPROM CONTROL 1 REGISTER

R/W-x	R/W-x	U-0	R/W-0	R/W-x	R/W-0	R/S-0	R/S-0
EEPGD	CFGS	—	FREE	WRERR	WREN	WR	RD
bit 7							bit 0

### Legend:

R = Readable bit	W = Writable bit
S = Bit can be set by software, but not cleared	U = Unimplemented bit, read as '0'
-n = Value at POR	'1' = Bit is set
	'0' = Bit is cleared
	x = Bit is unknown

- bit 7      **EEPGD:** Flash Program or Data EEPROM Memory Select bit  
 1 = Access Flash program memory  
 0 = Access data EEPROM memory
- bit 6      **CFGS:** Flash Program/Data EEPROM or Configuration Select bit  
 1 = Access Configuration registers  
 0 = Access Flash program or data EEPROM memory
- bit 5      **Unimplemented:** Read as '0'
- bit 4      **FREE:** Flash Row (Block) Erase Enable bit  
 1 = Erase the program memory block addressed by TBLPTR on the next WR command  
           (cleared by completion of erase operation)  
 0 = Perform write-only
- bit 3      **WRERR:** Flash Program/Data EEPROM Error Flag bit<sup>(1)</sup>  
 1 = A write operation is prematurely terminated (any Reset during self-timed programming in normal  
           operation, or an improper write attempt)  
 0 = The write operation completed
- bit 2      **WREN:** Flash Program/Data EEPROM Write Enable bit  
 1 = Allows write cycles to Flash program/data EEPROM  
 0 = Inhibits write cycles to Flash program/data EEPROM
- bit 1      **WR:** Write Control bit  
 1 = Initiates a data EEPROM erase/write cycle or a program memory erase cycle or write cycle.  
           (The operation is self-timed and the bit is cleared by hardware once write is complete.  
           The WR bit can only be set (not cleared) by software.)  
 0 = Write cycle to the EEPROM is complete
- bit 0      **RD:** Read Control bit  
 1 = Initiates an EEPROM read (Read takes one cycle. RD is cleared by hardware. The RD bit can only  
           be set (not cleared) by software. RD bit cannot be set when EEPGD = 1 or CFGS = 1.)  
 0 = Does not initiate an EEPROM read

**Note 1:** When a WRERR occurs, the EEPGD and CFGS bits are not cleared. This allows tracing of the error condition.

## 5.3 Reading the Data EEPROM Memory

To read a data memory location, the user must write the address to the EEADR register, clear the EEPGD control bit of the EECON1 register and then set control bit, RD. The data is available on the very next instruction cycle; therefore, the EEDATA register can be read by the next instruction. EEDATA will hold this value until another read operation, or until it is written to by the user (during a write operation).

The basic process is shown in [Example 5-1](#).

## 5.4 Writing to the Data EEPROM Memory

To write an EEPROM data location, the address must first be written to the EEADR register and the data written to the EEDATA register. The sequence in [Example 5-2](#) must be followed to initiate the write cycle.

The write will not begin if this sequence is not exactly followed (write 55h to EECON2, write 0AAh to EECON2, then set WR bit) for each byte. It is strongly recommended that interrupts be disabled during this code segment.

Additionally, the WREN bit in EECON1 must be set to enable writes. This mechanism prevents accidental writes to data EEPROM due to unexpected code execution (i.e., runaway programs). The WREN bit should be kept clear at all times, except when updating the EEPROM. The WREN bit is not cleared by hardware.

After a write sequence has been initiated, EECON1, EEADR and EEDATA cannot be modified. The WR bit will be inhibited from being set unless the WREN bit is set. Both WR and WREN cannot be set with the same instruction.

At the completion of the write cycle, the WR bit is cleared by hardware and the EEPROM Interrupt Flag bit, EEIF, is set. The user may either enable this interrupt or poll this bit. EEIF must be cleared by software.

## 5.5 Write Verify

Depending on the application, good programming practice may dictate that the value written to the memory should be verified against the original value. This should be used in applications where excessive writes can stress bits near the specification limit.

### EXAMPLE 5-1: DATA EEPROM READ

```

MOVLW DATA_EE_ADDR ;
MOVWF EEADR          ; Data Memory Address to read
BCF   EECON1, EEPGD  ; Point to DATA memory
BCF   EECON1, CFGS   ; Access EEPROM
BSF   EECON1, RD     ; EEPROM Read
MOVF  EEDATA, W      ; W = EEDATA
    
```

### EXAMPLE 5-2: DATA EEPROM WRITE

```

MOVLW DATA_EE_ADDR_LOW ;
MOVWF EEADR              ; Data Memory Address to write
MOVLW DATA_EE_DATA     ;
MOVWF EEDATA            ; Data Memory Value to write
BCF   EECON1, EEPGD     ; Point to DATA memory
BCF   EECON1, CFGS     ; Access EEPROM
BSF   EECON1, WREN     ; Enable writes
BCF   INTCON, GIE      ; Disable Interrupts
MOVLW 55h               ;
Required MOVWF EECON2    ; Write 55h
Sequence MOVLW 0AAh     ;
MOVWF EECON2            ; Write 0AAh
BSF   EECON1, WR       ; Set WR bit to begin write
BSF   INTCON, GIE      ; Enable Interrupts
; User code execution
BCF   EECON1, WREN     ; Disable writes on write complete (EEIF set)
    
```

# PIC18(L)F1XK22

## 5.6 Operation During Code-Protect

Data EEPROM memory has its own code-protect bits in Configuration Words. External read and write operations are disabled if code protection is enabled.

The microcontroller itself can both read and write to the internal data EEPROM, regardless of the state of the code-protect Configuration bit. Refer to [Section 22.0 “Special Features of the CPU”](#) for additional information.

## 5.7 Protection Against Spurious Write

There are conditions when the user may not want to write to the data EEPROM memory. To protect against spurious EEPROM writes, various mechanisms have been implemented. On power-up, the WREN bit is cleared. In addition, writes to the EEPROM are blocked during the Power-up Timer period (TPWRT, parameter 33).

The write initiate sequence and the WREN bit together help prevent an accidental write during brown-out, power glitch or software malfunction.

## 5.8 Using the Data EEPROM

The data EEPROM is a high-endurance, byte addressable array that has been optimized for the storage of frequently changing information (e.g., program variables or other data that are updated often). When variables in one section change frequently, while variables in another section do not change, it is possible to exceed the total number of write cycles to the EEPROM without exceeding the total number of write cycles to a single byte. If this is the case, then an array refresh must be performed. For this reason, variables that change infrequently (such as constants, IDs, calibration, etc.) should be stored in Flash program memory.

### EXAMPLE 5-3: DATA EEPROM REFRESH ROUTINE

	CLRF	EEADR		; Start at address 0
	BCF	EECON1, CFGS		; Set for memory
	BCF	EECON1, EEPGD		; Set for Data EEPROM
	BCF	INTCON, GIE		; Disable interrupts
	BSF	EECON1, WREN		; Enable writes
Loop				; Loop to refresh array
	BSF	EECON1, RD		; Read current address
	MOVLW	55h		;
	MOVWF	EECON2		; Write 55h
	MOVLW	0AAh		;
	MOVWF	EECON2		; Write 0AAh
	BSF	EECON1, WR		; Set WR bit to begin write
	BTFSC	EECON1, WR		; Wait for write to complete
	BRA	\$-2		;
	INCF	EEADR, F		; Increment address
	BRA	LOOP		; Not zero, do it again
	BCF	EECON1, WREN		; Disable writes
	BSF	INTCON, GIE		; Enable interrupts

TABLE 5-1: REGISTERS ASSOCIATED WITH DATA EEPROM MEMORY

Name	Bit 7	Bit 6	Bit 5	Bit 4	Bit 3	Bit 2	Bit 1	Bit 0	Reset Values on page
EEADR	EEADR7	EEADR6	EEADR5	EEADR4	EEADR3	EEADR2	EEADR1	EEADR0	255
EECON1	EEPGD	CFGS	—	FREE	WRERR	WREN	WR	RD	255
EECON2	EEPROM Control Register 2 (not a physical register)								255
EEDATA	EEPROM Data Register								255
INTCON	GIE/GIEH	PEIE/GIEL	TMR0IE	INT0IE	RABIE	TMR0IF	INT0IF	RABIF	253
IPR2	OSCFIP	C1IP	C2IP	EEIP	BCLIP	—	TMR3IP	—	256
PIE2	OSCFIE	C1IE	C2IE	EEIE	BCLIE	—	TMR3IE	—	256
PIR2	OSCFIF	C1IF	C2IF	EEIF	BCLIF	—	TMR3IF	—	256

**Legend:** — = unimplemented, read as '0'. Shaded cells are not used during Flash/EEPROM access.

## 6.0 8 x 8 HARDWARE MULTIPLIER

### 6.1 Introduction

All PIC18 devices include an 8 x 8 hardware multiplier as part of the ALU. The multiplier performs an unsigned operation and yields a 16-bit result that is stored in the product register pair, PRODH:PRODL. The multiplier's operation does not affect any flags in the STATUS register.

Making multiplication a hardware operation allows it to be completed in a single instruction cycle. This has the advantages of higher computational throughput and reduced code size for multiplication algorithms and allows the PIC18 devices to be used in many applications previously reserved for digital signal processors. A comparison of various hardware and software multiply operations, along with the savings in memory and execution time, is shown in [Table 6-1](#).

### 6.2 Operation

[Example 6-1](#) shows the instruction sequence for an 8 x 8 unsigned multiplication. Only one instruction is required when one of the arguments is already loaded in the WREG register.

[Example 6-2](#) shows the sequence to do an 8 x 8 signed multiplication. To account for the sign bits of the arguments, each argument's Most Significant bit (MSb) is tested and the appropriate subtractions are done.

#### EXAMPLE 6-1: 8 x 8 UNSIGNED MULTIPLY ROUTINE

```
MOVWF ARG1, W ;
MULWF ARG2 ; ARG1 * ARG2 ->
; PRODH:PRODL
```

#### EXAMPLE 6-2: 8 x 8 SIGNED MULTIPLY ROUTINE

```
MOVWF ARG1, W
MULWF ARG2 ; ARG1 * ARG2 ->
; PRODH:PRODL

BTFSC ARG2, SB ; Test Sign Bit
SUBWF PRODH, F ; PRODH = PRODH
; - ARG1

MOVWF ARG2, W
BTFSC ARG1, SB ; Test Sign Bit
SUBWF PRODH, F ; PRODH = PRODH
; - ARG2
```

**TABLE 6-1: PERFORMANCE COMPARISON FOR VARIOUS MULTIPLY OPERATIONS**

Routine	Multiply Method	Program Memory (Words)	Cycles (Max)	Time		
				@ 40 MHz	@ 10 MHz	@ 4 MHz
8 x 8 unsigned	Without hardware multiply	13	69	6.9 μs	27.6 μs	69 μs
	Hardware multiply	1	1	100 ns	400 ns	1 μs
8 x 8 signed	Without hardware multiply	33	91	9.1 μs	36.4 μs	91 μs
	Hardware multiply	6	6	600 ns	2.4 μs	6 μs
16 x 16 unsigned	Without hardware multiply	21	242	24.2 μs	96.8 μs	242 μs
	Hardware multiply	28	28	2.8 μs	11.2 μs	28 μs
16 x 16 signed	Without hardware multiply	52	254	25.4 μs	102.6 μs	254 μs
	Hardware multiply	35	40	4.0 μs	16.0 μs	40 μs

# PIC18(L)F1XK22

Example 6-3 shows the sequence to do a 16 x 16 unsigned multiplication. Equation 6-1 shows the algorithm that is used. The 32-bit result is stored in four registers (RES<3:0>).

## EQUATION 6-1: 16 x 16 UNSIGNED MULTIPLICATION ALGORITHM

$$\begin{aligned} \text{RES3:RES0} &= \text{ARG1H:ARG1L} \cdot \text{ARG2H:ARG2L} \\ &= (\text{ARG1H} \cdot \text{ARG2H} \cdot 2^{16}) + \\ &\quad (\text{ARG1H} \cdot \text{ARG2L} \cdot 2^8) + \\ &\quad (\text{ARG1L} \cdot \text{ARG2H} \cdot 2^8) + \\ &\quad (\text{ARG1L} \cdot \text{ARG2L}) \end{aligned}$$

## EXAMPLE 6-3: 16 x 16 UNSIGNED MULTIPLY ROUTINE

```

MOVF ARG1L, W
MULWF ARG2L          ; ARG1L * ARG2L->
                      ; PRODH:PRODL

MOVFF PRODH, RES1   ;
MOVFF PRODL, RES0   ;
;

MOVF ARG1H, W
MULWF ARG2H          ; ARG1H * ARG2H->
                      ; PRODH:PRODL

MOVFF PRODH, RES3   ;
MOVFF PRODL, RES2   ;
;

MOVF ARG1L, W
MULWF ARG2H          ; ARG1L * ARG2H->
                      ; PRODH:PRODL

MOVF PRODL, W
ADDWF RES1, F        ; Add cross
MOVF PRODH, W        ; products
ADDWFC RES2, F
CLRF WREG
ADDWFC RES3, F
;

MOVF ARG1H, W
MULWF ARG2L          ; ARG1H * ARG2L->
                      ; PRODH:PRODL

MOVF PRODL, W
ADDWF RES1, F        ; Add cross
MOVF PRODH, W        ; products
ADDWFC RES2, F
CLRF WREG
ADDWFC RES3, F

```

Example 6-4 shows the sequence to do a 16 x 16 signed multiply. Equation 6-2 shows the algorithm used. The 32-bit result is stored in four registers (RES<3:0>). To account for the sign bits of the arguments, the MSb for each argument pair is tested and the appropriate subtractions are done.

## EQUATION 6-2: 16 x 16 SIGNED MULTIPLICATION ALGORITHM

$$\begin{aligned} \text{RES3:RES0} &= \text{ARG1H:ARG1L} \cdot \text{ARG2H:ARG2L} \\ &= (\text{ARG1H} \cdot \text{ARG2H} \cdot 2^{16}) + \\ &\quad (\text{ARG1H} \cdot \text{ARG2L} \cdot 2^8) + \\ &\quad (\text{ARG1L} \cdot \text{ARG2H} \cdot 2^8) + \\ &\quad (\text{ARG1L} \cdot \text{ARG2L}) + \\ &\quad (-1 \cdot \text{ARG2H} < 7 > \cdot \text{ARG1H:ARG1L} \cdot 2^{16}) + \\ &\quad (-1 \cdot \text{ARG1H} < 7 > \cdot \text{ARG2H:ARG2L} \cdot 2^{16}) \end{aligned}$$

## EXAMPLE 6-4: 16 x 16 SIGNED MULTIPLY ROUTINE

```

MOVF ARG1L, W
MULWF ARG2L          ; ARG1L * ARG2L ->
                      ; PRODH:PRODL

MOVFF PRODH, RES1   ;
MOVFF PRODL, RES0   ;
;

MOVF ARG1H, W
MULWF ARG2H          ; ARG1H * ARG2H ->
                      ; PRODH:PRODL

MOVFF PRODH, RES3   ;
MOVFF PRODL, RES2   ;
;

MOVF ARG1L, W
MULWF ARG2H          ; ARG1L * ARG2H ->
                      ; PRODH:PRODL

MOVF PRODL, W
ADDWF RES1, F        ; Add cross
MOVF PRODH, W        ; products
ADDWFC RES2, F
CLRF WREG
ADDWFC RES3, F
;

MOVF ARG1H, W
MULWF ARG2L          ; ARG1H * ARG2L ->
                      ; PRODH:PRODL

MOVF PRODL, W
ADDWF RES1, F        ; Add cross
MOVF PRODH, W        ; products
ADDWFC RES2, F
CLRF WREG
ADDWFC RES3, F
;

BTFS ARG2H, 7        ; ARG2H:ARG2L neg?
BRA SIGN_ARG1        ; no, check ARG1
MOVF ARG1L, W
SUBWF RES2
MOVF ARG1H, W
SUBWFB RES3
;

SIGN_ARG1
BTFS ARG1H, 7        ; ARG1H:ARG1L neg?
BRA CONT_CODE        ; no, done
MOVF ARG2L, W
SUBWF RES2
MOVF ARG2H, W
SUBWFB RES3
;

CONT_CODE
:

```

## 7.0 INTERRUPTS

The PIC18(L)F1XK22 devices have multiple interrupt sources and an interrupt priority feature that allows most interrupt sources to be assigned a high priority level or a low priority level. The high priority interrupt vector is at 0008h and the low priority interrupt vector is at 0018h. A high priority interrupt event will interrupt a low priority interrupt that may be in progress.

There are twelve registers which are used to control interrupt operation. These registers are:

- RCON
- INTCON
- INTCON2
- INTCON3
- PIR1, PIR2
- PIE1, PIE2
- IPR1, IPR2

It is recommended that the Microchip header files supplied with MPLAB® IDE be used for the symbolic bit names in these registers. This allows the assembler/compiler to automatically take care of the placement of these bits within the specified register.

In general, interrupt sources have three bits to control their operation. They are:

- **Flag bit** to indicate that an interrupt event occurred
- **Enable bit** that allows program execution to branch to the interrupt vector address when the flag bit is set
- **Priority bit** to select high priority or low priority

### 7.1 Mid-Range Compatibility

When the IPEN bit is cleared (default state), the interrupt priority feature is disabled and interrupts are compatible with PIC® microcontroller mid-range devices. In Compatibility mode, the interrupt priority bits of the IPRx registers have no effect. The PEIE bit of the INTCON register is the global interrupt enable for the peripherals. The PEIE bit disables only the peripheral interrupt sources and enables the peripheral interrupt sources when the GIE bit is also set. The GIE bit of the INTCON register is the global interrupt enable which enables all non-peripheral interrupt sources and disables all interrupt sources, including the peripherals. All interrupts branch to address 0008h in Compatibility mode.

### 7.2 Interrupt Priority

The interrupt priority feature is enabled by setting the IPEN bit of the RCON register. When interrupt priority is enabled the GIE and PEIE global interrupt enable bits of Compatibility mode are replaced by the GIEH high priority, and GIEL low priority, global interrupt enables. When set, the GIEH bit of the INTCON register enables all interrupts that have their associated IPRx register or INTCONx register priority bit set (high priority). When clear, the GIEL bit disables all interrupt sources including those selected as low priority. When clear, the GIEL bit of the INTCON register disables only the interrupts that have their associated priority bit cleared (low priority). When set, the GIEL bit enables the low priority sources when the GIEH bit is also set.

When the interrupt flag, enable bit and appropriate global interrupt enable bit are all set, the interrupt will vector immediately to address 0008h for high priority, or 0018h for low priority, depending on level of the interrupting source's priority bit. Individual interrupts can be disabled through their corresponding interrupt enable bits.

### 7.3 Interrupt Response

When an interrupt is responded to, the global interrupt enable bit is cleared to disable further interrupts. The GIE bit is the global interrupt enable when the IPEN bit is cleared. When the IPEN bit is set, enabling interrupt priority levels, the GIEH bit is the high priority global interrupt enable and the GIEL bit is the low priority global interrupt enable. High priority interrupt sources can interrupt a low priority interrupt. Low priority interrupts are not processed while high priority interrupts are in progress.

The return address is pushed onto the stack and the PC is loaded with the interrupt vector address (0008h or 0018h). Once in the Interrupt Service Routine, the source(s) of the interrupt can be determined by polling the interrupt flag bits in the INTCONx and PIRx registers. The interrupt flag bits must be cleared by software before re-enabling interrupts to avoid repeating the same interrupt.

The "return from interrupt" instruction, `RETFIE`, exits the interrupt routine and sets the GIE bit (GIEH or GIEL if priority levels are used), which re-enables interrupts.

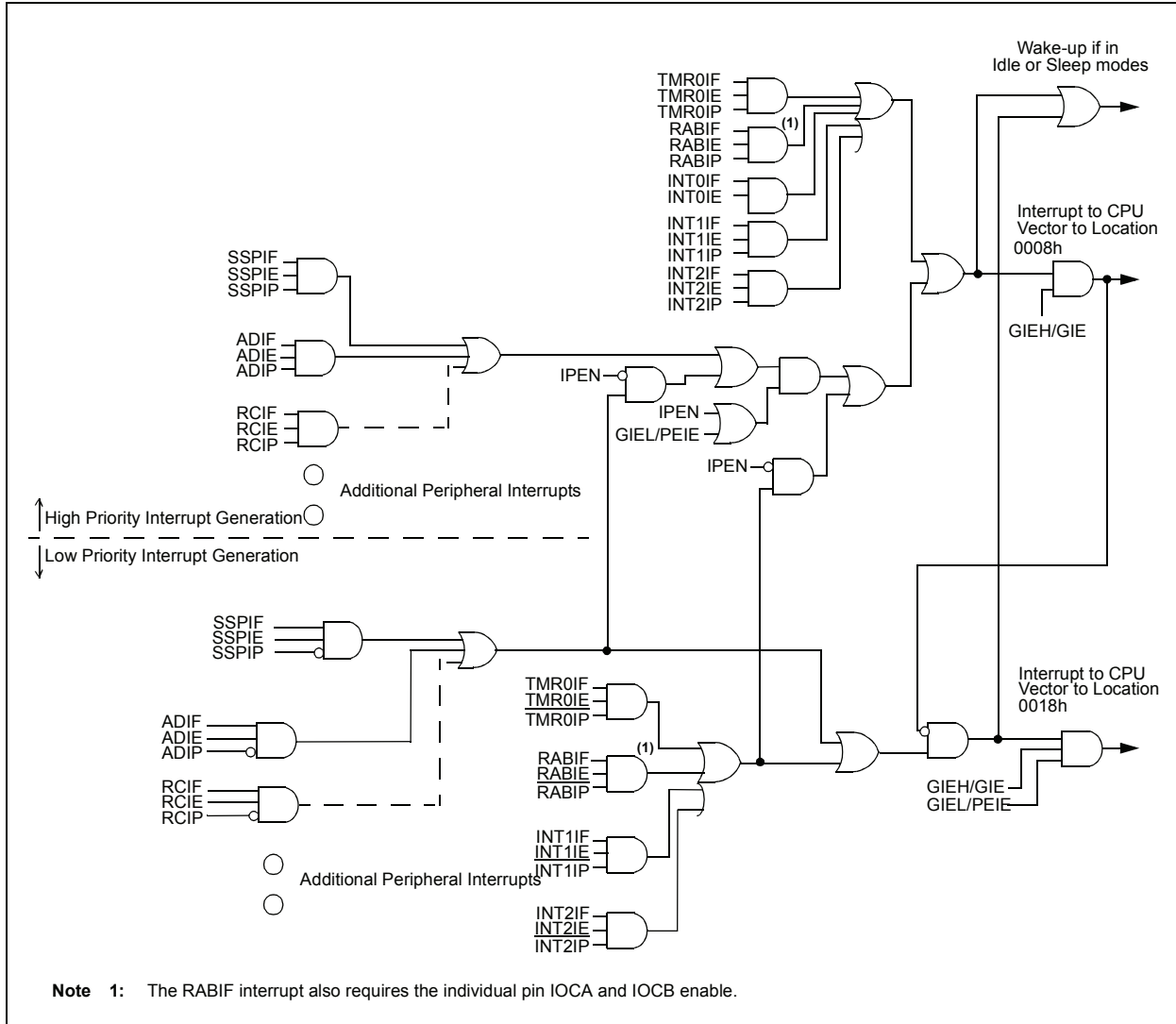
# PIC18(L)F1XK22

For external interrupt events, such as the INT pins or the PORTB interrupt-on-change, the interrupt latency will be three to four instruction cycles. The exact latency is the same for one-cycle or two-cycle

instructions. Individual interrupt flag bits are set, regardless of the status of their corresponding enable bits or the global interrupt enable bit.

**Note:** Do not use the MOVFF instruction to modify any of the interrupt control registers while **any** interrupt is enabled. Doing so may cause erratic microcontroller behavior.

**FIGURE 7-1: PIC18 INTERRUPT LOGIC**





## 7.4 INTCON Registers

The INTCON registers are readable and writable registers, which contain various enable, priority and flag bits.

**Note:** Interrupt flag bits are set when an interrupt condition occurs, regardless of the state of its corresponding enable bit or the global enable bit. User software should ensure the appropriate interrupt flag bits are clear prior to enabling an interrupt. This feature allows for software polling.

### REGISTER 7-1: INTCON: INTERRUPT CONTROL REGISTER

R/W-0	R/W-0	R/W-0	R/W-0	R/W-0	R/W-0	R/W-0	R/W-x
GIE/GIEH	PEIE/GIEL	TMR0IE	INT0IE	RABIE	TMR0IF	INT0IF	RABIF
bit 7							bit 0

**Legend:**

R = Readable bit	W = Writable bit	U = Unimplemented bit, read as '0'
-n = Value at POR	'1' = Bit is set	'0' = Bit is cleared
		x = Bit is unknown

- bit 7      **GIE/GIEH:** Global Interrupt Enable bit  
When IPEN = 0:  
 1 = Enables all unmasked interrupts  
 0 = Disables all interrupts including peripherals  
When IPEN = 1:  
 1 = Enables all high priority interrupts  
 0 = Disables all interrupts including low priority
- bit 6      **PEIE/GIEL:** Peripheral Interrupt Enable bit  
When IPEN = 0:  
 1 = Enables all unmasked peripheral interrupts  
 0 = Disables all peripheral interrupts  
When IPEN = 1:  
 1 = Enables all low priority interrupts  
 0 = Disables all low priority interrupts
- bit 5      **TMR0IE:** TMR0 Overflow Interrupt Enable bit  
 1 = Enables the TMR0 overflow interrupt  
 0 = Disables the TMR0 overflow interrupt
- bit 4      **INT0IE:** INT0 External Interrupt Enable bit  
 1 = Enables the INT0 external interrupt  
 0 = Disables the INT0 external interrupt
- bit 3      **RABIE:** RA and RB Port Change Interrupt Enable bit<sup>(2)</sup>  
 1 = Enables the RA and RB port change interrupt  
 0 = Disables the RA and RB port change interrupt
- bit 2      **TMR0IF:** TMR0 Overflow Interrupt Flag bit  
 1 = TMR0 register has overflowed (must be cleared by software)  
 0 = TMR0 register did not overflow
- bit 1      **INT0IF:** INT0 External Interrupt Flag bit  
 1 = The INT0 external interrupt occurred (must be cleared by software)  
 0 = The INT0 external interrupt did not occur
- bit 0      **RABIF:** RA and RB Port Change Interrupt Flag bit<sup>(1)</sup>  
 1 = At least one of the RA <5:0> or RB <7:4> pins changed state (must be cleared by software)  
 0 = None of the RA <5:0> or RB <7:4> pins have changed state

- Note 1:** A mismatch condition will continue to set the RABIF bit. Reading PORTA and PORTB will end the mismatch condition and allow the bit to be cleared.
- Note 2:** RA and RB port change interrupts also require the individual pin IOCA and IOCB enable.

# PIC18(L)F1XK22

## REGISTER 7-2: INTCON2: INTERRUPT CONTROL 2 REGISTER

R/W-1	R/W-1	R/W-1	R/W-1	U-0	R/W-1	U-0	R/W-1
RABPU	INTEDG0	INTEDG1	INTEDG2	—	TMR0IP	—	RABIP
bit 7							bit 0

### Legend:

R = Readable bit

W = Writable bit

U = Unimplemented bit, read as '0'

-n = Value at POR

'1' = Bit is set

'0' = Bit is cleared

x = Bit is unknown

- bit 7 **RABPU**: PORTA and PORTB Pull-up Enable bit  
1 = PORTA and PORTB pull-ups are disabled  
0 = PORTA and PORTB pull-ups are enabled provided that the pin is an input and the corresponding WPUA and WPUB bits are set.
- bit 6 **INTEDG0**: External Interrupt 0 Edge Select bit  
1 = Interrupt on rising edge  
0 = Interrupt on falling edge
- bit 5 **INTEDG1**: External Interrupt 1 Edge Select bit  
1 = Interrupt on rising edge  
0 = Interrupt on falling edge
- bit 4 **INTEDG2**: External Interrupt 2 Edge Select bit  
1 = Interrupt on rising edge  
0 = Interrupt on falling edge
- bit 3 **Unimplemented**: Read as '0'
- bit 2 **TMR0IP**: TMR0 Overflow Interrupt Priority bit  
1 = High priority  
0 = Low priority
- bit 1 **Unimplemented**: Read as '0'
- bit 0 **RABIP**: RA and RB Port Change Interrupt Priority bit  
1 = High priority  
0 = Low priority

**Note:** Interrupt flag bits are set when an interrupt condition occurs, regardless of the state of its corresponding enable bit or the global enable bit. User software should ensure the appropriate interrupt flag bits are clear prior to enabling an interrupt. This feature allows for software polling.

## REGISTER 7-3: INTCON3: INTERRUPT CONTROL 3 REGISTER

R/W-1	R/W-1	U-0	R/W-0	R/W-0	U-0	R/W-0	R/W-0
INT2IP	INT1IP	—	INT2IE	INT1IE	—	INT2IF	INT1IF
bit 7						bit 0	

### Legend:

R = Readable bit

W = Writable bit

U = Unimplemented bit, read as '0'

-n = Value at POR

'1' = Bit is set

'0' = Bit is cleared

x = Bit is unknown

- bit 7      **INT2IP:** INT2 External Interrupt Priority bit  
             1 = High priority  
             0 = Low priority
- bit 6      **INT1IP:** INT1 External Interrupt Priority bit  
             1 = High priority  
             0 = Low priority
- bit 5      **Unimplemented:** Read as '0'
- bit 4      **INT2IE:** INT2 External Interrupt Enable bit  
             1 = Enables the INT2 external interrupt  
             0 = Disables the INT2 external interrupt
- bit 3      **INT1IE:** INT1 External Interrupt Enable bit  
             1 = Enables the INT1 external interrupt  
             0 = Disables the INT1 external interrupt
- bit 2      **Unimplemented:** Read as '0'
- bit 1      **INT2IF:** INT2 External Interrupt Flag bit  
             1 = The INT2 external interrupt occurred (must be cleared by software)  
             0 = The INT2 external interrupt did not occur
- bit 0      **INT1IF:** INT1 External Interrupt Flag bit  
             1 = The INT1 external interrupt occurred (must be cleared by software)  
             0 = The INT1 external interrupt did not occur

**Note:** Interrupt flag bits are set when an interrupt condition occurs, regardless of the state of its corresponding enable bit or the global enable bit. User software should ensure the appropriate interrupt flag bits are clear prior to enabling an interrupt. This feature allows for software polling.

# PIC18(L)F1XK22

## 7.5 PIR Registers

The PIR registers contain the individual flag bits for the peripheral interrupts. Due to the number of peripheral interrupt sources, there are two Peripheral Interrupt Request Flag registers (PIR1 and PIR2).

**Note 1:** Interrupt flag bits are set when an interrupt condition occurs, regardless of the state of its corresponding enable bit or the Global Interrupt Enable bit, GIE of the INTCON register.

**2:** User software should ensure the appropriate interrupt flag bits are cleared prior to enabling an interrupt and after servicing that interrupt.

### REGISTER 7-4: PIR1: PERIPHERAL INTERRUPT REQUEST (FLAG) REGISTER 1

U-0	R/W-0	R-0	R-0	R/W-0	R/W-0	R/W-0	R/W-0
—	ADIF	RCIF	TXIF	SSPIF	CCP1IF	TMR2IF	TMR1IF
bit 7							bit 0

#### Legend:

R = Readable bit

W = Writable bit

U = Unimplemented bit, read as '0'

-n = Value at POR

'1' = Bit is set

'0' = Bit is cleared

x = Bit is unknown

bit 7 **Unimplemented:** Read as '0'

bit 6 **ADIF:** A/D Converter Interrupt Flag bit

1 = An A/D conversion completed (must be cleared by software)

0 = The A/D conversion is not complete or has not been started

bit 5 **RCIF:** EUSART Receive Interrupt Flag bit

1 = The EUSART receive buffer, RCREG, is full (cleared when RCREG is read)

0 = The EUSART receive buffer is empty

bit 4 **TXIF:** EUSART Transmit Interrupt Flag bit

1 = The EUSART transmit buffer, TXREG, is empty (cleared when TXREG is written)

0 = The EUSART transmit buffer is full

bit 3 **SSPIF:** Master Synchronous Serial Port Interrupt Flag bit

1 = The transmission/reception is complete (must be cleared by software)

0 = Waiting to transmit/receive

bit 2 **CCP1IF:** CCP1 Interrupt Flag bit

Capture mode:

1 = A TMR1 register capture occurred (must be cleared by software)

0 = No TMR1 register capture occurred

Compare mode:

1 = A TMR1 register compare match occurred (must be cleared by software)

0 = No TMR1 register compare match occurred

PWM mode:

Unused in this mode

bit 1 **TMR2IF:** TMR2 to PR2 Match Interrupt Flag bit

1 = TMR2 to PR2 match occurred (must be cleared by software)

0 = No TMR2 to PR2 match occurred

bit 0 **TMR1IF:** TMR1 Overflow Interrupt Flag bit

1 = TMR1 register overflowed (must be cleared by software)

0 = TMR1 register did not overflow

**Note 1:** The PSPIF bit is unimplemented on 28-pin devices and will read as '0'.

## REGISTER 7-5: PIR2: PERIPHERAL INTERRUPT REQUEST (FLAG) REGISTER 2

R/W-0	R/W-0	R/W-0	R/W-0	R/W-0	U-0	R/W-0	U-0
OSCFIF	C1IF	C2IF	EEIF	BCLIF	—	TMR3IF	—
bit 7						bit 0	

### Legend:

R = Readable bit

W = Writable bit

U = Unimplemented bit, read as '0'

-n = Value at POR

'1' = Bit is set

'0' = Bit is cleared

x = Bit is unknown

- bit 7      **OSCFIF:** Oscillator Fail Interrupt Flag bit  
 1 = Device oscillator failed, clock input has changed to HFINTOSC (must be cleared by software)  
 0 = Device clock operating
- bit 6      **C1IF:** Comparator C1 Interrupt Flag bit  
 1 = Comparator C1 output has changed (must be cleared by software)  
 0 = Comparator C1 output has not changed
- bit 5      **C2IF:** Comparator C2 Interrupt Flag bit  
 1 = Comparator C2 output has changed (must be cleared by software)  
 0 = Comparator C2 output has not changed
- bit 4      **EEIF:** Data EEPROM/Flash Write Operation Interrupt Flag bit  
 1 = The write operation is complete (must be cleared by software)  
 0 = The write operation is not complete or has not been started
- bit 3      **BCLIF:** Bus Collision Interrupt Flag bit  
 1 = A bus collision occurred (must be cleared by software)  
 0 = No bus collision occurred
- bit 2      **Unimplemented:** Read as '0'
- bit 1      **TMR3IF:** TMR3 Overflow Interrupt Flag bit  
 1 = TMR3 register overflowed (must be cleared by software)  
 0 = TMR3 register did not overflow
- bit 0      **Unimplemented:** Read as '0'

# PIC18(L)F1XK22

## 7.6 PIE Registers

The PIE registers contain the individual enable bits for the peripheral interrupts. Due to the number of peripheral interrupt sources, there are two Peripheral Interrupt Enable registers (PIE1 and PIE2). When IPEN = 0, the PEIE bit must be set to enable any of these peripheral interrupts.

### REGISTER 7-6: PIE1: PERIPHERAL INTERRUPT ENABLE (FLAG) REGISTER 1

U-0	R/W-0	R/W-0	R/W-0	R/W-0	R/W-0	R/W-0	R/W-0
—	ADIE	RCIE	TXIE	SSPIE	CCP1IE	TMR2IE	TMR1IE
bit 7							bit 0

#### Legend:

R = Readable bit

W = Writable bit

U = Unimplemented bit, read as '0'

-n = Value at POR

'1' = Bit is set

'0' = Bit is cleared

x = Bit is unknown

- bit 7      **Unimplemented:** Read as '0'
- bit 6      **ADIE:** A/D Converter Interrupt Enable bit  
1 = Enables the A/D interrupt  
0 = Disables the A/D interrupt
- bit 5      **RCIE:** EUSART Receive Interrupt Enable bit  
1 = Enables the EUSART receive interrupt  
0 = Disables the EUSART receive interrupt
- bit 4      **TXIE:** EUSART Transmit Interrupt Enable bit  
1 = Enables the EUSART transmit interrupt  
0 = Disables the EUSART transmit interrupt
- bit 3      **SSPIE:** Master Synchronous Serial Port Interrupt Enable bit  
1 = Enables the MSSP interrupt  
0 = Disables the MSSP interrupt
- bit 2      **CCP1IE:** CCP1 Interrupt Enable bit  
1 = Enables the CCP1 interrupt  
0 = Disables the CCP1 interrupt
- bit 1      **TMR2IE:** TMR2 to PR2 Match Interrupt Enable bit  
1 = Enables the TMR2 to PR2 match interrupt  
0 = Disables the TMR2 to PR2 match interrupt
- bit 0      **TMR1IE:** TMR1 Overflow Interrupt Enable bit  
1 = Enables the TMR1 overflow interrupt  
0 = Disables the TMR1 overflow interrupt

# PIC18(L)F1XK22

## REGISTER 7-7: PIE2: PERIPHERAL INTERRUPT ENABLE (FLAG) REGISTER 2

R/W-0	R/W-0	R/W-0	R/W-0	R/W-0	U-0	R/W-0	U-0
OSCFIE	C1IE	C2IE	EEIE	BCLIE	—	TMR3IE	—
bit 7							bit 0

### Legend:

R = Readable bit

W = Writable bit

U = Unimplemented bit, read as '0'

-n = Value at POR

'1' = Bit is set

'0' = Bit is cleared

x = Bit is unknown

bit 7	<b>OSCFIE:</b> Oscillator Fail Interrupt Enable bit 1 = Enabled 0 = Disabled
bit 6	<b>C1IE:</b> Comparator C1 Interrupt Enable bit 1 = Enabled 0 = Disabled
bit 5	<b>C2IE:</b> Comparator C2 Interrupt Enable bit 1 = Enabled 0 = Disabled
bit 4	<b>EEIE:</b> Data EEPROM/Flash Write Operation Interrupt Enable bit 1 = Enabled 0 = Disabled
bit 3	<b>BCLIE:</b> Bus Collision Interrupt Enable bit 1 = Enabled 0 = Disabled
bit 2	<b>Unimplemented:</b> Read as '0'
bit 1	<b>TMR3IE:</b> TMR3 Overflow Interrupt Enable bit 1 = Enabled 0 = Disabled
bit 0	<b>Unimplemented:</b> Read as '0'

# PIC18(L)F1XK22

## 7.7 IPR Registers

The IPR registers contain the individual priority bits for the peripheral interrupts. Due to the number of peripheral interrupt sources, there are two Peripheral Interrupt Priority registers (IPR1 and IPR2). Using the priority bits requires that the Interrupt Priority Enable (IPEN) bit be set.

### REGISTER 7-8: IPR1: PERIPHERAL INTERRUPT PRIORITY REGISTER 1

U-0	R/W-1	R/W-1	R/W-1	R/W-1	R/W-1	R/W-1	R/W-1
—	ADIP	RCIP	TXIP	SSPIP	CCP1IP	TMR2IP	TMR1IP
bit 7							bit 0

#### Legend:

R = Readable bit

W = Writable bit

U = Unimplemented bit, read as '0'

-n = Value at POR

'1' = Bit is set

'0' = Bit is cleared

x = Bit is unknown

bit 7	<b>Unimplemented:</b> Read as '0'
bit 6	<b>ADIP:</b> A/D Converter Interrupt Priority bit 1 = High priority 0 = Low priority
bit 5	<b>RCIP:</b> EUSART Receive Interrupt Priority bit 1 = High priority 0 = Low priority
bit 4	<b>TXIP:</b> EUSART Transmit Interrupt Priority bit 1 = High priority 0 = Low priority
bit 3	<b>SSPIP:</b> Master Synchronous Serial Port Interrupt Priority bit 1 = High priority 0 = Low priority
bit 2	<b>CCP1IP:</b> CCP1 Interrupt Priority bit 1 = High priority 0 = Low priority
bit 1	<b>TMR2IP:</b> TMR2 to PR2 Match Interrupt Priority bit 1 = High priority 0 = Low priority
bit 0	<b>TMR1IP:</b> TMR1 Overflow Interrupt Priority bit 1 = High priority 0 = Low priority



## REGISTER 7-9: IPR2: PERIPHERAL INTERRUPT PRIORITY REGISTER 2

R/W-1	R/W-1	R/W-1	R/W-1	R/W-1	U-0	R/W-1	U-0
OSCFIP	C1IP	C2IP	EEIP	BCLIP	—	TMR3IP	—
bit 7						bit 0	

### Legend:

R = Readable bit

W = Writable bit

U = Unimplemented bit, read as '0'

-n = Value at POR

'1' = Bit is set

'0' = Bit is cleared

x = Bit is unknown

bit 7 **OSCFIP:** Oscillator Fail Interrupt Priority bit

1 = High priority

0 = Low priority

bit 6 **C1IP:** Comparator C1 Interrupt Priority bit

1 = High priority

0 = Low priority

bit 5 **C2IP:** Comparator C2 Interrupt Priority bit

1 = High priority

0 = Low priority

bit 4 **EEIP:** Data EEPROM/Flash Write Operation Interrupt Priority bit

1 = High priority

0 = Low priority

bit 3 **BCLIP:** Bus Collision Interrupt Priority bit

1 = High priority

0 = Low priority

bit 2 **Unimplemented:** Read as '0'

bit 1 **TMR3IP:** TMR3 Overflow Interrupt Priority bit

1 = High priority

0 = Low priority

bit 0 **Unimplemented:** Read as '0'

# PIC18(L)F1XK22

## 7.8 RCON Register

The RCON register contains flag bits which are used to determine the cause of the last Reset or wake-up from Idle or Sleep modes. RCON also contains the IPEN bit which enables interrupt priorities.

The operation of the SBOREN bit and the Reset flag bits is discussed in more detail in [Section 21.1 “RCON Register”](#).

### REGISTER 7-10: RCON: RESET CONTROL REGISTER

R/W-0	R/W-1	U-0	R/W-1	R-1	R-1	R/W-0	R/W-0
IPEN	SBOREN <sup>(1)</sup>	—	$\overline{\text{RI}}$	$\overline{\text{TO}}$	$\overline{\text{PD}}$	$\overline{\text{POR}}^{\text{(2)}}$	$\overline{\text{BOR}}$
bit 7							bit 0

#### Legend:

R = Readable bit	W = Writable bit	U = Unimplemented bit, read as '0'
-n = Value at POR	'1' = Bit is set	'0' = Bit is cleared
		x = Bit is unknown

- bit 7      **IPEN:** Interrupt Priority Enable bit  
 1 = Enable priority levels on interrupts  
 0 = Disable priority levels on interrupts (PIC16CXXX Compatibility mode)
- bit 6      **SBOREN:** BOR Software Enable bit<sup>(1)</sup>  
If BOREN<1:0> = 01:  
 1 = BOR is enabled  
 0 = BOR is disabled  
If BOREN<1:0> = 00, 10 or 11:  
 Bit is disabled and read as '0'.
- bit 5      **Unimplemented:** Read as '0'
- bit 4       **$\overline{\text{RI}}$ :** RESET Instruction Flag bit  
 1 = The RESET instruction was not executed (set by firmware or Power-on Reset)  
 0 = The RESET instruction was executed causing a device Reset (must be set in firmware after a code-executed Reset occurs)
- bit 3       **$\overline{\text{TO}}$ :** Watchdog Time-out Flag bit  
 1 = Set by power-up, CLRWDT instruction or SLEEP instruction  
 0 = A WDT Time-out occurred
- bit 2       **$\overline{\text{PD}}$ :** Power-down Detection Flag bit  
 1 = Set by power-up or by the CLRWDT instruction  
 0 = Set by execution of the SLEEP instruction
- bit 1       **$\overline{\text{POR}}$ :** Power-on Reset Status bit<sup>(2)</sup>  
 1 = No Power-on Reset occurred  
 0 = A Power-on Reset occurred (must be set in software after a Power-on Reset occurs)
- bit 0       **$\overline{\text{BOR}}$ :** Brown-out Reset Status bit<sup>(3)</sup>  
 1 = A Brown-out Reset has not occurred (set by firmware only)  
 0 = A Brown-out Reset occurred (must be set by firmware after a POR or Brown-out Reset occurs)

- Note 1:** If SBOREN is enabled, its Reset state is '1'; otherwise, it is '0'.
- Note 2:** The actual Reset value of  $\overline{\text{POR}}$  is determined by the type of device Reset. See the notes following this register and [Section 21.6 “Reset State of Registers”](#) for additional information.
- Note 3:** See [Table 21-3](#).

## 7.9 INTx Pin Interrupts

External interrupts on the RA0/INT0, RA1/INT1 and RA2/INT2 pins are edge-triggered. If the corresponding INTEDGx bit in the INTCON2 register is set (= 1), the interrupt is triggered by a rising edge; if the bit is clear, the trigger is on the falling edge. When a valid edge appears on the RAx/INTx pin, the corresponding flag bit, INTxF, is set. This interrupt can be disabled by clearing the corresponding enable bit, INTxE. Flag bit, INTxF, must be cleared by software in the Interrupt Service Routine before re-enabling the interrupt.

All external interrupts (INT0, INT1 and INT2) can wake-up the processor from Idle or Sleep modes if bit INTxE was set prior to going into those modes. If the Global Interrupt Enable bit, GIE, is set, the processor will branch to the interrupt vector following wake-up.

Interrupt priority for INT1 and INT2 is determined by the value contained in the interrupt priority bits, INT1IP and INT2IP of the INTCON3 register. There is no priority bit associated with INT0. It is always a high priority interrupt source.

## 7.10 TMR0 Interrupt

In 8-bit mode (which is the default), an overflow in the TMR0 register (FFh → 00h) will set flag bit, TMR0IF. In 16-bit mode, an overflow in the TMR0H:TMR0L register pair (FFFFh → 0000h) will set TMR0IF. The interrupt can be enabled/disabled by setting/clearing enable bit, TMR0IE of the INTCON register. Interrupt priority for Timer0 is determined by the value contained in the interrupt priority bit, TMR0IP of the INTCON2 register. See [Section 9.0 “Timer0 Module”](#) for further details on the Timer0 module.

## 7.11 PORTA and PORTB Interrupt-on-Change

An input change on PORTA or PORTB sets flag bit, RABIF of the INTCON register. The interrupt can be enabled/disabled by setting/clearing enable bit, RABIE of the INTCON register. Pins must also be individually enabled with the IOCA and IOCB register. Interrupt priority for PORTA and PORTB interrupt-on-change is determined by the value contained in the interrupt priority bit, RABIP of the INTCON2 register.

## 7.12 Context Saving During Interrupts

During interrupts, the return PC address is saved on the stack. Additionally, the WREG, STATUS and BSR registers are saved on the fast return stack. If a fast return from interrupt is not used (see [Section 3.3 “Data Memory Organization”](#)), the user may need to save the WREG, STATUS and BSR registers on entry to the Interrupt Service Routine. Depending on the user's application, other registers may also need to be saved. [Example 7-1](#) saves and restores the WREG, STATUS and BSR registers during an Interrupt Service Routine.

### EXAMPLE 7-1: SAVING STATUS, WREG AND BSR REGISTERS IN RAM

```

MOVWF    W_TEMP                ; W_TEMP is in virtual bank
MOVFF    STATUS, STATUS_TEMP    ; STATUS_TEMP located anywhere
MOVFF    BSR, BSR_TEMP          ; BSR_TEMP located anywhere
;
; USER ISR CODE
;
MOVFF    BSR_TEMP, BSR          ; Restore BSR
MOVFF    W_TEMP, W              ; Restore WREG
MOVFF    STATUS_TEMP, STATUS    ; Restore STATUS
    
```

# PIC18(L)F1XK22

---

NOTES:

## 8.0 I/O PORTS

There are up to three ports available. Some pins of the I/O ports are multiplexed with an alternate function from the peripheral features on the device. In general, when a peripheral is enabled, that pin may not be used as a general purpose I/O pin.

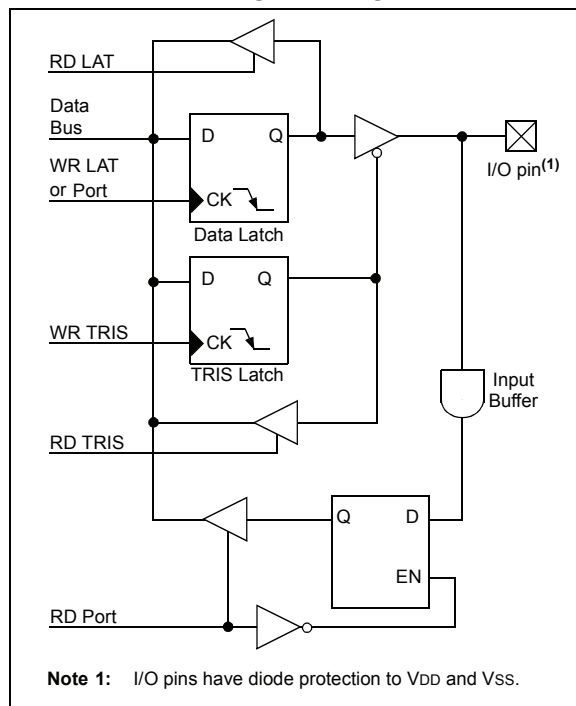
Each port has three registers for its operation. These registers are:

- TRIS register (data direction register)
- PORT register (reads the levels on the pins of the device)
- LAT register (output latch)

The PORTA Data Latch (LATA register) is useful for read-modify-write operations on the value that the I/O pins are driving.

A simplified model of a generic I/O port, without the interfaces to other peripherals, is shown in [Figure 8-1](#).

**FIGURE 8-1: GENERIC I/O PORT OPERATION**



## 8.1 PORTA, TRISA and LATA Registers

PORTA is 5 bits wide. PORTA<5:4,2:0> bits are bidirectional ports and PORTA is an input-only port. The corresponding data direction register is TRISA. Setting a TRISA bit (= 1) will make the corresponding PORTA pin an input (i.e., disable the output driver). Clearing a TRISA bit (= 0) will make the corresponding PORTA pin an output (i.e., enable the output driver and put the contents of the output latch on the selected pin).

Reading the PORTA register reads the status of the pins, whereas writing to it, will write to the PORT latch.

The PORTA Data Latch (LATA) register is also memory mapped. Read-modify-write operations on the LATA register read and write the latched output value for PORTA.

All of the PORTA pins are individually configurable as interrupt-on-change pins. Control bits in the IOCA register enable (when set) or disable (when clear) the interrupt function for each pin.

When set, the RABIE bit of the INTCON register enables interrupts on all pins which also have their corresponding IOCA bit set. When clear, the RABIE bit disables all interrupt-on-changes.

Only pins configured as inputs can cause this interrupt to occur (i.e., any pin configured as an output is excluded from the interrupt-on-change comparison).

For enabled interrupt-on-change pins, the values are compared with the old value latched on the last read of PORTA. The 'mismatch' outputs of the last read are OR'd together to set the PORTA Change Interrupt flag bit (RABIF) in the INTCON register.

# PIC18(L)F1XK22

This interrupt can wake the device from the Sleep mode, or any of the Idle modes. The user, in the Interrupt Service Routine, can clear the interrupt in the following manner:

- a) Any read or write of PORTA to clear the mismatch condition (except when PORTA is the source or destination of a `MOVFF` instruction).
- b) Clear the flag bit, RABIF.

A mismatch condition will continue to set the RABIF flag bit. Reading or writing PORTA will end the mismatch condition and allow the RABIF bit to be cleared. The latch holding the last read value is not affected by a `MCLR` nor Brown-out Reset. After either one of these Resets, the RABIF flag will continue to be set if a mismatch is present.

**Note 1:** If a change on the I/O pin should occur when the read operation is being executed (start of the Q2 cycle), then the RABIF interrupt flag may not get set. Furthermore, since a read or write on a port affects all bits of that port, care must be taken when using multiple pins in Interrupt-on-change mode. Changes on one pin may not be seen while servicing changes on another pin.

The interrupt-on-change feature is recommended for wake-up on key depression operation and operations where PORTA is only used for the interrupt-on-change feature. Polling of PORTA is not recommended while using the interrupt-on-change feature.

Each of the PORTA pins has an individually controlled weak internal pull-up. When set, each bit of the WPUA register enables the corresponding pin pull-up. When cleared, the RABPU bit of the INTCON2 register enables pull-ups on all pins which also have their corresponding WPUA bit set. When set, the RABPU bit disables all weak pull-ups. The weak pull-up is automatically turned off when the port pin is configured as an output. The pull-ups are disabled on a Power-on Reset.

RA3 is an input only pin. Its operation is controlled by the MCLRE bit of the CONFIG3H register. When selected as a port pin (`MCLRE = 0`), it functions as a digital input only pin; as such, it does not have TRIS or LAT bits associated with its operation.

**Note:** On a Power-on Reset, RA3 is enabled as a digital input only if Master Clear functionality is disabled.

Pins RA4 and RA5 are multiplexed with the main oscillator pins; they are enabled as oscillator or I/O pins by the selection of the main oscillator in the Configuration register (see [Section 22.1 “Configuration Bits”](#) for details). When they are not used as port pins, RA4 and RA5 and their associated TRIS and LAT bits read as '0'.

RA<4,2:0> are pins multiplexed with analog inputs. The operation of pins RA<4,2:0> as analog are selected by setting the ANS<3:0> bits in the ANSEL register, which is the default setting after a Power-on Reset.

## EXAMPLE 8-1: INITIALIZING PORTA

```
CLRF   PORTA   ; Initialize PORTA by
              ; clearing output
              ; data latches
CLRF   LATA    ; Alternate method
              ; to clear output
              ; data latches
MOVLW  030h   ; Value used to
              ; initialize data
              ; direction
MOVWF  TRISA   ; Set RA<5:4> as output
```

## REGISTER 8-1: PORTA: PORTA REGISTER

U-0	U-0	R/W-x	R/W-x	R-x	R/W-x	R/W-x	R/W-x
—	—	RA5	RA4	RA3	RA2	RA1	RA0
bit 7							bit 0

### Legend:

R = Readable bit                      W = Writable bit                      U = Unimplemented bit, read as '0'  
 -n = Value at POR                      '1' = Bit is set                      '0' = Bit is cleared                      x = Bit is unknown

bit 7-6                      **Unimplemented:** Read as '0'  
 bit 5-0                      **RA<5:0>:** PORTA I/O Pin bit<sup>(1)</sup>  
                                     1 = Port pin is > VIH  
                                     0 = Port pin is < VIL

**Note 1:** The RA3 bit is only available when Master Clear Reset is disabled (MCLR Configuration bit = 0). Otherwise, RA3 reads as '0'. This bit is read-only.

## REGISTER 8-2: TRISA: PORTA TRI-STATE REGISTER

U-0	U-0	R/W-1	R/W-1	U-1	R/W-1	R/W-1	R/W-1
—	—	TRISA5	TRISA4	—	TRISA2	TRISA1	TRISA0
bit 7							bit 0

### Legend:

R = Readable bit                      W = Writable bit                      U = Unimplemented bit, read as '0'  
 -n = Value at POR                      '1' = Bit is set                      '0' = Bit is cleared                      x = Bit is unknown

bit 7-6                      **Unimplemented:** Read as '0'  
 bit 5-4                      **TRISA<5:4>:** PORTA Tri-State Control bit<sup>(1)</sup>  
                                     1 = PORTA pin configured as an input (tri-stated)  
                                     0 = PORTA pin configured as an output  
 bit 3                      **Unimplemented:** Read as '1'  
 bit 2-0                      **TRISA<2:0>:** PORTA Tri-State Control bit<sup>(1)</sup>  
                                     1 = PORTA pin configured as an input (tri-stated)  
                                     0 = PORTA pin configured as an output

**Note 1:** TRISA<5:4> always reads '1' in XT, HS and LP Oscillator modes.

# PIC18(L)F1XK22

## REGISTER 8-3: LATA: PORTA DATA LATCH REGISTER

U-0	U-0	R/W-x	R/W-x	U-0	R/W-x	R/W-x	R/W-x
—	—	LATA5	LATA4	—	LATA2	LATA1	LATA0
bit 7							bit 0

### Legend:

R = Readable bit                      W = Writable bit                      U = Unimplemented bit, read as '0'  
 -n = Value at POR                      '1' = Bit is set                      '0' = Bit is cleared                      x = Bit is unknown

bit 7-6                      **Unimplemented:** Read as '0'  
 bit 5-4                      **LATA<5:4>:** RA<5:4> Port I/O Output Latch Register bits  
 bit 3                      **Unimplemented:** Read as '0'  
 bit 2-0                      **LATA<2:0>:** RA<2:0> Port I/O Output Latch Register bits

## REGISTER 8-4: WPUA: WEAK PULL-UP PORTA REGISTER

U-0	U-0	R/W-1	R/W-1	R/W-1	R/W-1	R/W-1	R/W-1
—	—	WPUA5	WPUA4	WPUA3	WPUA2	WPUA1	WPUA0
bit 7							bit 0

### Legend:

R = Readable bit                      W = Writable bit                      U = Unimplemented bit, read as '0'  
 -n = Value at POR                      '1' = Bit is set                      '0' = Bit is cleared                      x = Bit is unknown

bit 7-6                      **Unimplemented:** Read as '0'  
 bit 5-0                      **WPUA<5:0>:** Weak Pull-up Enable bit  
    1 = Pull-up enabled  
    0 = Pull-up disabled

## REGISTER 8-5: IOCA: INTERRUPT-ON-CHANGE PORTA REGISTER

U-0	U-0	R/W-0	R/W-0	R/W-0	R/W-0	R/W-0	R/W-0
—	—	IOCA5	IOCA4	IOCA3	IOCA2	IOCA1	IOCA0
bit 7							bit 0

### Legend:

R = Readable bit                      W = Writable bit                      U = Unimplemented bit, read as '0'  
 -n = Value at POR                      '1' = Bit is set                      '0' = Bit is cleared                      x = Bit is unknown

bit 7-6                      **Unimplemented:** Read as '0'  
 bit 5-0                      **IOCA<5:0>:** PORTA I/O Pin bit  
    1 = Interrupt-on-change enabled  
    0 = Interrupt-on-change disabled



**TABLE 8-1: PORTA I/O SUMMARY**

Pin	Function	TRIS Setting	I/O	I/O Type	Description
RA0/AN0/CVREF/ VREF-/C1IN+/INT0/ PGD	RA0	0	O	DIG	LATA<0> data output.
		1	I	TTL	PORTA<0> data input; Programmable weak pull-up.
	AN0	1	I	ANA	ADC channel 0 input.
	CVREF	x	O	ANA	Comparator reference voltage output.
	VREF-	1	I	ANA	ADC and Comparator voltage reference voltage (low) input.
	C1IN+	1	I	DIG	Comparator C1 non-inverting input.
	INT0	1	I	ST	External interrupt 0.
	PGD	x	O	DIG	Serial execution data output for ICSP™.
x		I	ST	Serial execution data input for ICSP™.	
RA1/AN1/C12IN0-/ VREF+/INT1/PGC	RA1	0	O	DIG	LATA<1> data output.
		1	I	TTL	PORTA<1> data input; Programmable weak pull-up.
	AN1	1	I	ANA	ADC channel 1.
	C12IN0-	1	I	ANA	Comparator C1 and C2 non-inverting input channel 0.
	VREF+	1	I	ANA	Comparator reference voltage (high) input ADC qual.
	INT1	1	I	ST	External interrupt 1.
	PGC	x	O	DIG	Serial execution clock output for ICSP™.
x		I	ST	Serial execution clock input for ICSP™.	
RA2/AN2/C1OUT/ T0CKI/INT2/SRQ	RA2	0	O	DIG	LATA<2> data output.
		1	I	TTL	PORTA<2> data input; Programmable weak pull-up.
	AN2	1	I	ANA	ADC channel 2.
	C1OUT	0	O	DIG	Comparator C1 output.
	T0CKI	1	I	ST	Timer0 external clock input.
	INT2	1	I	ST	External interrupt 2.
RA3/MCLR/VPP	RA3	— <sup>(1)</sup>	I	ST	PORTA<37> data input; Programmable weak pull-up.
	MCLR	—	I	ST	Active-low Master Clear with internal pull-up.
	VPP	—	I	ANA	High voltage programming input.
RA4/AN3/OSC2/ CLKOUT	RA4	0	O	DIG	LATA<4> data output.
		1	I	TTL	PORTA<4> data input; Programmable weak pull-up.
	AN3	1	I	ANA	A/D input channel 3.
	OSC2	x	O	ANA	Main oscillator feedback output connection (XT, HS and LP modes).
	CLKOUT	x	O	DIG	System instruction cycle clock output.
RA5/OSC1/CLKIN/ T13CKI	RA5	0	O	DIG	LATA<5> data output.
		1	I	TTL	PORTA<5> data input; Programmable weak pull-up.
	OSC1	x	I	ANA	Main oscillator input connection.
	CLKIN	x	I	ANA	Main clock input connection.
	T13CKI	1	I	ST	Timer1 and Timer3 external clock input.

**Legend:** DIG = Digital level output; TTL = TTL input buffer; ST = Schmitt Trigger input buffer; ANA = Analog level input/output; x = Don't care (TRIS bit does not affect port direction or is overridden for this option).

**Note 1:** RA3 does not have a corresponding TRISA bit. This pin is always an input regardless of mode.

# PIC18(L)F1XK22

**TABLE 8-2: SUMMARY OF REGISTERS ASSOCIATED WITH PORTA**

Name	Bit 7	Bit 6	Bit 5	Bit 4	Bit 3	Bit 2	Bit 1	Bit 0	Reset Values on page
ANSEL	ANS7	ANS6	ANS5	ANS4	ANS3	ANS2	ANS1	ANS0	256
INTCON	GIE/GIEH	PEIE/GIEL	TMR0IE	INT0IE	RABIE	TMR0IF	INT0IF	RABIF	253
INTCON2	RABPU	INTEDG0	INTEDG1	INTEDG2	—	TMR0IP	—	RABIP	253
IOCA	—	—	IOCA5	IOCA4	IOCA3 <sup>(2)</sup>	IOCA2	IOCA1	IOCA0	256
LATA	—	—	LATA5 <sup>(1)</sup>	LATA4 <sup>(1)</sup>	—	LATA2	LATA1	LATA0	256
PORTA	—	—	RA5 <sup>(1)</sup>	RA4 <sup>(1)</sup>	RA3 <sup>(2)</sup>	RA2	RA1	RA0	256
SLRCON	—	—	—	—	—	SLRC	SLRB	SLRA	256
TRISA	—	—	TRISA5 <sup>(1)</sup>	TRISA4 <sup>(1)</sup>	—	TRISA2	TRISA1	TRISA0	256
WPUA	—	—	WPUA5	WPUA4	WPUA3 <sup>(2)</sup>	WPUA2	WPUA1	WPUA0	253

**Legend:** — = unimplemented, read as '0'. Shaded cells are not used by PORTA.

**Note 1:** RA<5:4> and their associated latch and data direction bits are enabled as I/O pins based on oscillator configuration; otherwise, they are read as '0'.

**2:** Implemented only when Master Clear functionality is disabled (MCLRE Configuration bit = 0).

## 8.2 PORTB, TRISB and LATB Registers

PORTB is an 4-bit wide, bidirectional port. The corresponding data direction register is TRISB. Setting a TRISB bit (= 1) will make the corresponding PORTB pin an input (i.e., disable the output driver). Clearing a TRISB bit (= 0) will make the corresponding PORTB pin an output (i.e., enable the output driver and put the contents of the output latch on the selected pin).

The PORTB Data Latch register (LATB) is also memory mapped. Read-modify-write operations on the LATB register read and write the latched output value for PORTB.

### EXAMPLE 8-2: INITIALIZING PORTB

```
CLRF   PORTB   ; Initialize PORTB by
              ; clearing output
              ; data latches
CLRF   LATB    ; Alternate method
              ; to clear output
              ; data latches
MOVLW  0F0h   ; Value used to
              ; initialize data
              ; direction
MOVWF  TRISB  ; Set RB<7:4> as outputs
```

All PORTB pins are individually configurable as interrupt-on-change pins. Control bits in the IOCB register enable (when set) or disable (when clear) the interrupt function for each pin.

When set, the RABIE bit of the INTCON register enables interrupts on all pins which also have their corresponding IOCB bit set. When clear, the RABIE bit disables all interrupt-on-changes.

Only pins configured as inputs can cause this interrupt to occur (i.e., any pin configured as an output is excluded from the interrupt-on-change comparison).

For enabled interrupt-on-change pins, the values are compared with the old value latched on the last read of PORTB. The 'mismatch' outputs of the last read are OR'd together to set the PORTB Change Interrupt flag bit (RABIF) in the INTCON register.

This interrupt can wake the device from the Sleep mode, or any of the Idle modes. The user, in the Interrupt Service Routine, can clear the interrupt in the following manner:

- a) Any read or write of PORTB to clear the mismatch condition (except when PORTB is the source or destination of a MOVFF instruction).
- b) Clear the flag bit, RABIF.

A mismatch condition will continue to set the RABIF flag bit. Reading or writing PORTB will end the mismatch condition and allow the RABIF bit to be cleared. The latch holding the last read value is not affected by a MCLR nor Brown-out Reset. After either one of these Resets, the RABIF flag will continue to be set if a mismatch is present.

**Note:** If a change on the I/O pin should occur when the read operation is being executed (start of the Q2 cycle), then the RABIF interrupt flag may not get set. Furthermore, since a read or write on a port affects all bits of that port, care must be taken when using multiple pins in interrupt-on-change mode. Changes on one pin may not be seen while servicing changes on another pin.

The interrupt-on-change feature is recommended for wake-up on key depression operation and operations where PORTB is only used for the interrupt-on-change feature. Polling of PORTB is not recommended while using the interrupt-on-change feature.

All PORTB pins have individually controlled weak internal pull-up. When set, each bit of the WPUB register enables the corresponding pin pull-up. When cleared, the  $\overline{\text{RABPU}}$  bit of the INTCON2 register enables pull-ups on all pins which also have their corresponding WPUB bit set. When set, the RABPU bit disables all weak pull-ups. The weak pull-up is automatically turned off when the port pin is configured as an output. The pull-ups are disabled on a Power-on Reset.

**Note:** On a Power-on Reset, RB<5:4> are configured as analog inputs by default and read as '0'.

# PIC18(L)F1XK22

## REGISTER 8-6: PORTB: PORTB REGISTER

R/W-x	R/W-x	R/W-x	R/W-x	U-0	U-0	U-0	U-0
RB7	RB6	RB5	RB4	—	—	—	—
bit 7							bit 0

### Legend:

R = Readable bit                      W = Writable bit                      U = Unimplemented bit, read as '0'  
 -n = Value at POR                      '1' = Bit is set                      '0' = Bit is cleared                      x = Bit is unknown

bit 7-4                      **RB<7:4>**: PORTB I/O Pin bit  
                                     1 = Port pin is >V<sub>IH</sub>  
                                     0 = Port pin is <V<sub>IL</sub>  
 bit 3-0                      **Unimplemented**: Read as '0'

## REGISTER 8-7: TRISB: PORTB TRI-STATE REGISTER

R/W-1	R/W-1	R/W-1	R/W-1	U-0	U-0	U-0	U-0
TRISB7	TRISB6	TRISB5	TRISB4	—	—	—	—
bit 7							bit 0

### Legend:

R = Readable bit                      W = Writable bit                      U = Unimplemented bit, read as '0'  
 -n = Value at POR                      '1' = Bit is set                      '0' = Bit is cleared                      x = Bit is unknown

bit 7-4                      **TRISB<7:4>**: PORTB Tri-State Control bit  
                                     1 = PORTB pin configured as an input (tri-stated)  
                                     0 = PORTB pin configured as an output  
 bit 3-0                      **Unimplemented**: Read as '0'

## REGISTER 8-8: LATB: PORTB DATA LATCH REGISTER

R/W-x	R/W-x	R/W-x	R/W-x	U-0	U-0	U-0	U-0
LATB7	LATB6	LATB5	LATB4	—	—	—	—
bit 7							bit 0

### Legend:

R = Readable bit                      W = Writable bit                      U = Unimplemented bit, read as '0'  
 -n = Value at POR                      '1' = Bit is set                      '0' = Bit is cleared                      x = Bit is unknown

bit 7-4                      **LATB<7:4>**: RB<7:4> Port I/O Output Latch Register bits  
 bit 3-0                      **Unimplemented**: Read as '0'

## REGISTER 8-9: WPUB: WEAK PULL-UP PORTB REGISTER

R/W-1	R/W-1	R/W-1	R/W-1	U-0	U-0	U-0	U-0
WPUB7	WPUB6	WPUB5	WPUB4	—	—	—	—
bit 7							bit 0

### Legend:

R = Readable bit                      W = Writable bit                      U = Unimplemented bit, read as '0'  
 -n = Value at POR                      '1' = Bit is set                      '0' = Bit is cleared                      x = Bit is unknown

bit 7-4                      **WPUB<7:4>**: Weak Pull-up Enable bit  
                                     1 = Pull-up enabled  
                                     0 = Pull-up disabled

bit 3-0                      **Unimplemented**: Read as '0'

## REGISTER 8-10: IOCB: INTERRUPT-ON-CHANGE PORTB REGISTER

R/W-0	R/W-0	R/W-0	R/W-0	U-0	U-0	U-0	U-0
IOCB7	IOCB6	IOCB5	IOCB4	—	—	—	—
bit 7							bit 0

### Legend:

R = Readable bit                      W = Writable bit                      U = Unimplemented bit, read as '0'  
 -n = Value at POR                      '1' = Bit is set                      '0' = Bit is cleared                      x = Bit is unknown

bit 7-4                      **IOCB<7:4>**: Interrupt-on-change bits  
                                     1 = Interrupt-on-change enabled  
                                     0 = Interrupt-on-change disabled

bit 3-0                      **Unimplemented**: Read as '0'

# PIC18(L)F1XK22

**TABLE 8-3: PORTB I/O SUMMARY**

Pin	Function	TRIS Setting	I/O	I/O Type	Description
RB4/AN10/SDI/SDA	RB4	0	O	DIG	LATB<4> data output.
		1	I	TTL	PORTB<4> data input; Programmable weak pull-up.
	AN10	1	I	ANA	ADC input channel 10.
	SDI	1	I	ST	SPI data input (MSSP module).
	SDA	1	O	DIG	I <sup>2</sup> C™ data output (MSSP module).
1		I	I <sup>2</sup> C	I <sup>2</sup> C™ data input (MSSP module); input type depends on module setting.	
RB5/AN11/RX/DT	RB5	0	O	DIG	LATB<5> data output.
		1	I	TTL	PORTB<5> data input; Programmable weak pull-up.
	AN11	1	I	ANA	ADC input channel 11.
	RX	1	I	ST	Asynchronous serial receive data input (USART module).
	DT	1	O	DIG	Synchronous serial data output (USART module); takes priority over PORT data.
1		I	ST	Synchronous serial data input (USART module). User must configure as an input.	
RB6/SCK/SCL	RB6	0	O	DIG	LATB<6> data output.
		1	I	TTL	PORTB<6> data input; Programmable weak pull-up.
	SCK	0	O	DIG	SPI clock output (MSSP module).
		1	I	ST	SPI clock input (MSSP module).
	SCL	0	O	DIG	I <sup>2</sup> C™ clock output (MSSP module).
1		I	I <sup>2</sup> C	I <sup>2</sup> C™ clock input (MSSP module); input type depends on module setting.	
RB7/TX/CK	RB7	0	O	DIG	LATB<7> data output.
		1	I	TTL	PORTB<7> data input; Programmable weak pull-up.
	TX	1	O	DIG	Asynchronous serial transmit data output (USART module).
	CK	1	O	DIG	Synchronous serial clock output (USART module).
1		I	ST	Synchronous serial clock input (USART module).	

**Legend:** DIG = Digital level output; TTL = TTL input buffer; ST = Schmitt Trigger input buffer; ANA = Analog level input/output; I<sup>2</sup>C = Schmitt Trigger input with I<sup>2</sup>C; x = Don't care (TRIS bit does not affect port direction or is overridden for this option).

**TABLE 8-4: SUMMARY OF REGISTERS ASSOCIATED WITH PORTB**

Name	Bit 7	Bit 6	Bit 5	Bit 4	Bit 3	Bit 2	Bit 1	Bit 0	Reset Values on page
ANSELH	—	—	—	—	ANS11	ANS10	ANS9	ANS8	256
INTCON	GIE/GIEH	PEIE/GIEL	TMR0IE	INT0IE	RABIE	TMR0IF	INT0IF	RABIF	253
INTCON2	RABPU	INTEDG0	INTEDG1	INTEDG2	—	TMR0IP	—	RABIP	253
IOCB	IOCB7	IOCB6	IOCB5	IOCB4					256
LATB	LATB7	LATB6	LATB5	LATB4	—	—	—	—	256
PORTB	RB7	RB6	RB5	RB4	—	—	—	—	256
RCSTA	SPEN	RX9	SREN	CREN	ADDEN	FERR	OERR	RX9D	255
SLRCON	—	—	—	—	—	SLRC	SLRB	SLRA	256
SSPCON1	WCOL	SSPOV	SSPEN	CKP	SSPM3	SSPM2	SSPM1	SSPM0	254
TRISB	TRISB7	TRISB6	TRISB5	TRISB4	—	—	—	—	256
TXSTA	CSRC	TX9	TXEN	SYNC	SENDB	BRGH	TRMT	TX9D	255
WPUB	WPUB7	WPUB6	WPUB5	WPUB4	—	—	—	—	256

**Legend:** — = unimplemented, read as '0'. Shaded cells are not used by PORTB.

# PIC18(L)F1XK22

## 8.3 PORTC, TRISC and LATC Registers

PORTC is an 8-bit wide, bidirectional port. The corresponding data direction register is TRISC. Setting a TRISC bit (= 1) will make the corresponding PORTC pin an input (i.e., disable the output driver). Clearing a TRISC bit (= 0) will make the corresponding PORTC pin an output (i.e., enable the output driver and put the contents of the output latch on the selected pin).

The PORTC Data Latch register (LATC) is also memory mapped. Read-modify-write operations on the LATC register read and write the latched output value for PORTC.

All the pins on PORTC are implemented with Schmitt Trigger input buffer. Each pin is individually configurable as an input or output.

**Note:** On a Power-on Reset, RC<7:6> and RC<3:0> are configured as analog inputs and read as '0'.

### EXAMPLE 8-3: INITIALIZING PORTC

```
CLRF   PORTC   ; Initialize PORTC by
           ; clearing output
           ; data latches
CLRF   LATC    ; Alternate method
           ; to clear output
           ; data latches
MOVLW  0CFh   ; Value used to
           ; initialize data
           ; direction
MOVWF  TRISC   ; Set RC<3:0> as inputs
           ; RC<5:4> as outputs
           ; RC<7:6> as inputs
```

### REGISTER 8-11: PORTC: PORTC REGISTER

R/W-x	R/W-x	R/W-x	R/W-x	R/W-x	R/W-x	R/W-x	R/W-x
RC7	RC6	RC5	RC4	RC3	RC2	RC1	RC0
bit 7							bit 0

#### Legend:

R = Readable bit                      W = Writable bit                      U = Unimplemented bit, read as '0'  
 -n = Value at POR                      '1' = Bit is set                      '0' = Bit is cleared                      x = Bit is unknown

bit 7-0                      **RC<7:0>**: PORTC I/O Pin bits  
                                     1 = Port pin is > V<sub>IH</sub>  
                                     0 = Port pin is < V<sub>IL</sub>

### REGISTER 8-12: TRISC: PORTC TRI-STATE REGISTER

R/W-1	R/W-1	R/W-1	R/W-1	R/W-1	R/W-1	R/W-1	R/W-1
TRISC7	TRISC6	TRISC5	TRISC4	TRISC3	TRISC2	TRISC1	TRISC0
bit 7							bit 0

#### Legend:

R = Readable bit                      W = Writable bit                      U = Unimplemented bit, read as '0'  
 -n = Value at POR                      '1' = Bit is set                      '0' = Bit is cleared                      x = Bit is unknown

bit 7-0                      **TRISC<7:0>**: PORTC Tri-State Control bits  
                                     1 = PORTC pin configured as an input (tri-stated)  
                                     0 = PORTC pin configured as an output



## REGISTER 8-13: LATC: PORTC DATA LATCH REGISTER

R/W-x	R/W-x	R/W-x	R/W-x	R/W-x	R/W-x	R/W-x	R/W-x
LATC7	LATC6	LATC5	LATC4	LATC3	LATC2	LATC1	LATC0
bit 7							bit 0

### Legend:

R = Readable bit

W = Writable bit

U = Unimplemented bit, read as '0'

-n = Value at POR

'1' = Bit is set

'0' = Bit is cleared

x = Bit is unknown

bit 7-0

**LATC<7:0>**: RB<7:0> Port I/O Output Latch Register bits

# PIC18(L)F1XK22

**TABLE 8-5: PORTC I/O SUMMARY**

Pin	Function	TRIS Setting	I/O	I/O Type	Description
RC0/AN4/C2IN+	RC0	0	O	DIG	LATC<0> data output.
		1	I	ST	PORTC<0> data input.
	AN4	1	I	ANA	A/D input channel 4.
	C2IN+	1	I	ANA	Comparators C2 non-inverting input.
RC1/AN5/C12IN1-	RC1	0	O	DIG	LATC<1> data output.
		1	I	ST	PORTC<1> data input.
	AN5	1	I	ANA	A/D input channel 5.
	C12IN1-	1	I	ANA	Comparators C1 and C2 inverting input, channel 1.
RC2/AN6/C12IN2-	RC2	0	O	DIG	LATC<2> data output.
		1	I	ST	PORTC<2> data input.
	AN6	1	I	ANA	A/D input channel 6.
	C12IN2-	1	I	ANA	Comparators C1 and C2 inverting input, channel 2.
	P1D	0	O	DIG	ECCP1 Enhanced PWM output, channel D.
RC3/AN7/C12IN3-/P1C/PGM	RC3	0	O	DIG	LATC<3> data output.
		1	I	ST	PORTC<3> data input.
	AN7	1	I	ANA	A/D input channel 7.
	C12IN3-	1	I	ANA	Comparators C1 and C2 inverting input, channel 3.
	P1C	0	O	DIG	ECCP1 Enhanced PWM output, channel C.
RC4/C2OUT/P1B	RC4	0	O	DIG	LATC<4> data output.
		1	I	ST	PORTC<4> data input.
	C2OUT	0	O	DIG	Comparator 2 output.
	P1B	0	O	DIG	ECCP1 Enhanced PWM output, channel B.
	RC5/CCP1/P1A	RC5	0	O	DIG
1			I	ST	PORTC<5> data input.
CCP1		0	O	DIG	ECCP1 compare or PWM output.
		1	I	ST	ECCP1 capture input.
P1A		0	O	DIG	ECCP1 Enhanced PWM output, channel A.
RC6/AN8/SS	RC6	0	O	DIG	LATC<6> data output.
		1	I	ST	PORTC<6> data input.
	AN8	1	I	ANA	A/D input channel 8.
	SS	1	I	TTL	Slave select input for SSP (MSSP module)
RC7/AN9/SDO	RC7	0	O	DIG	LATC<7> data output.
		1	I	ST	PORTC<7> data input.
	AN9	1	I	ANA	A/D input channel 9.
	SDO	0	O	DIG	SPI data output (MSSP module).

**Legend:** DIG = Digital level output; TTL = TTL input buffer; ST = Schmitt Trigger input buffer; ANA = Analog level input/output; x = Don't care (TRIS bit does not affect port direction or is overridden for this option).

**TABLE 8-6: SUMMARY OF REGISTERS ASSOCIATED WITH PORTC**

Name	Bit 7	Bit 6	Bit 5	Bit 4	Bit 3	Bit 2	Bit 1	Bit 0	Reset Values on page
ANSEL	ANS7	ANS6	ANS5	ANS4	ANS3	ANS2	ANS1	ANS0	256
ANSELH	—	—	—	—	ANS11	ANS10	ANS9	ANS8	256
CCP1CON	P1M1	P1M0	DC1B1	DC1B0	CCP1M3	CCP1M2	CCP1M1	CCP1M0	255
ECCP1AS	ECCPASE	ECCPAS2	ECCPAS1	ECCPAS0	PSSAC1	PSSAC0	PSSBD1	PSSBD0	255
INTCON	GIE/GIEH	PEIE/GIEL	TMR0IE	INT0IE	RABIE	TMR0IF	INT0IF	RABIF	253
INTCON2	RABPU	INTEDG0	INTEDG1	INTEDG2	—	TMR0IP	—	RABIP	253
INTCON3	INT2IP	INT1IP	—	INT2IE	INT1IE	—	INT2IF	INT1IF	253
LATC	LATC7	LATC6	LATC5	LATC4	LATC3	LATC2	LATC1	LATC0	256
PORTC	RC7	RC6	RC5	RC4	RC3	RC2	RC1	RC0	256
PSTRCON	—	—	—	STRSYNC	STRD	STRC	STRB	STRA	255
VREFCON1	D1EN	D1LPS	DAC1OE	---	D1PSS1	D1PSS0	---	D1NSS	255
SLRCON	—	—	—	—	—	SLRC	SLRB	SLRA	256
SSPCON1	WCOL	SSPOV	SSPEN	CKP	SSPM3	SSPM2	SSPM1	SSPM0	254
TRISC	TRISC7	TRISC6	TRISC5	TRISC4	TRISC3	TRISC2	TRISC1	TRISC0	256
T1CON	RD16	T1RUN	T1CKPS1	T1CKPS0	T1OSCEN	T1SYNC	TMR1CS	TMR1ON	254
T3CON	RD16	—	T3CKPS1	T3CKPS0	T3CCP1	T3SYNC	TMR3CS	TMR3ON	255

# PIC18(L)F1XK22

## 8.4 Port Analog Control

Some port pins are multiplexed with analog functions such as the Analog-to-Digital Converter and comparators. When these I/O pins are to be used as analog inputs it is necessary to disable the digital input buffer to avoid excessive current caused by improper biasing of the digital input. Individual control of the digital input buffers on pins which share analog functions is provided by the ANSEL and ANSELH registers. Setting an

ANSx bit high will disable the associated digital input buffer and cause all reads of that pin to return '0' while allowing analog functions of that pin to operate correctly.

The state of the ANSx bits has no effect on digital output functions. A pin with the associated TRISx bit clear and ANSx bit set will still operate as a digital output but the Input mode will be analog.

**REGISTER 8-14: ANSEL: ANALOG SELECT REGISTER**

R/W-1	R/W-1	R/W-1	R/W-1	R/W-1	R/W-1	R/W-1	R/W-1
ANS7	ANS6	ANS5	ANS4	ANS3	ANS2	ANS1	ANS0
bit 7							bit 0

**Legend:**

R = Readable bit  
-n = Value at POR

W = Writable bit  
'1' = Bit is set

U = Unimplemented bit, read as '0'  
'0' = Bit is cleared  
x = Bit is unknown

- bit 7      **ANS7:** RC3 Analog Select Control bit  
1 = Digital input buffer of RC3 is disabled  
0 = Digital input buffer of RC3 is enabled
- bit 6      **ANS6:** RC2 Analog Select Control bit  
1 = Digital input buffer of RC2 is disabled  
0 = Digital input buffer of RC2 is enabled
- bit 5      **ANS5:** RC1 Analog Select Control bit  
1 = Digital input buffer of RC1 is disabled  
0 = Digital input buffer of RC1 is enabled
- bit 4      **ANS4:** RC0 Analog Select Control bit  
1 = Digital input buffer of RC0 is disabled  
0 = Digital input buffer of RC0 is enabled
- bit 3      **ANS3:** RA4 Analog Select Control bit  
1 = Digital input buffer of RA4 is disabled  
0 = Digital input buffer of RA4 is enabled
- bit 2      **ANS2:** RA2 Analog Select Control bit  
1 = Digital input buffer of RA2 is disabled  
0 = Digital input buffer of RA2 is enabled
- bit 1      **ANS1:** RA1 Analog Select Control bit  
1 = Digital input buffer of RA1 is disabled  
0 = Digital input buffer of RA1 is enabled
- bit 0      **ANS0:** RA0 Analog Select Control bit  
1 = Digital input buffer of RA0 is disabled  
0 = Digital input buffer of RA0 is enabled

## REGISTER 8-15: ANSELH: ANALOG SELECT HIGH REGISTER

U-0	U-0	U-0	U-0	R/W-1	R/W-1	R/W-1	R/W-1
—	—	—	—	ANS11	ANS10	ANS9	ANS8
bit 7				bit 0			

### Legend:

R = Readable bit

W = Writable bit

U = Unimplemented bit, read as '0'

-n = Value at POR

'1' = Bit is set

'0' = Bit is cleared

x = Bit is unknown

bit 7-4      **Unimplemented:** Read as '0'

bit 3      **ANS11:** RB5 Analog Select Control bit  
 1 = Digital input buffer of RB5 is disabled  
 0 = Digital input buffer of RB5 is enabled

bit 2      **ANS10:** RB4 Analog Select Control bit  
 1 = Digital input buffer of RB4 is disabled  
 0 = Digital input buffer of RB4 is enabled

bit 1      **ANS9:** RC7 Analog Select Control bit  
 1 = Digital input buffer of RC7 is disabled  
 0 = Digital input buffer of RC7 is enabled

bit 0      **ANS8:** RC6 Analog Select Control bit  
 1 = Digital input buffer of RC6 is disabled  
 0 = Digital input buffer of RC6 is enabled

# PIC18(L)F1XK22

## 8.5 Port Slew Rate Control

The output slew rate of each port is programmable to select either the standard transition rate or a reduced transition rate of 0.1 times the standard to minimize EMI. The reduced transition time is the default slew rate for all ports.

### REGISTER 8-16: SLRCON: SLEW RATE CONTROL REGISTER

U-0	U-0	U-0	U-0	U-0	R/W-1	R/W-1	R/W-1
—	—	—	—	—	SLRC	SLRB	SLRA
bit 7							bit 0

#### Legend:

R = Readable bit	W = Writable bit	U = Unimplemented bit, read as '0'	
-n = Value at POR	'1' = Bit is set	'0' = Bit is cleared	x = Bit is unknown

- bit 7-3      **Unimplemented:** Read as '0'
- bit 2      **SLRC:** PORTC Slew Rate Control bit  
1 = All outputs on PORTC slew at 0.1 times the standard rate  
0 = All outputs on PORTC slew at the standard rate
- bit 1      **SLRB:** PORTB Slew Rate Control bit  
1 = All outputs on PORTB slew at 0.1 times the standard rate  
0 = All outputs on PORTB slew at the standard rate
- bit 0      **SLRA:** PORTA Slew Rate Control bit  
1 = All outputs on PORTA slew at 0.1 times the standard rate<sup>(1)</sup>  
0 = All outputs on PORTA slew at the standard rate

**Note 1:** The slew rate of RA4 defaults to standard rate when the pin is used as CLKOUT.

## 9.0 TIMER0 MODULE

The Timer0 module incorporates the following features:

- Software selectable operation as a timer or counter in both 8-bit or 16-bit modes
- Readable and writable registers
- Dedicated 8-bit, software programmable prescaler
- Selectable clock source (internal or external)
- Edge select for external clock
- Interrupt-on-overflow

The T0CON register ([Register 9-1](#)) controls all aspects of the module's operation, including the prescale selection. It is both readable and writable.

A simplified block diagram of the Timer0 module in 8-bit mode is shown in [Figure 9-1](#). [Figure 9-2](#) shows a simplified block diagram of the Timer0 module in 16-bit mode.

### REGISTER 9-1: T0CON: TIMER0 CONTROL REGISTER

R/W-1	R/W-1	R/W-1	R/W-1	R/W-1	R/W-1	R/W-1	R/W-1
TMR0ON	T08BIT	T0CS	T0SE	PSA	T0PS2	T0PS1	T0PS0
bit 7							bit 0

#### Legend:

R = Readable bit

W = Writable bit

U = Unimplemented bit, read as '0'

-n = Value at POR

'1' = Bit is set

'0' = Bit is cleared

x = Bit is unknown

- bit 7      **TMR0ON:** Timer0 On/Off Control bit  
           1 = Enables Timer0  
           0 = Stops Timer0
- bit 6      **T08BIT:** Timer0 8-bit/16-bit Control bit  
           1 = Timer0 is configured as an 8-bit timer/counter  
           0 = Timer0 is configured as a 16-bit timer/counter
- bit 5      **T0CS:** Timer0 Clock Source Select bit  
           1 = Transition on T0CKI pin  
           0 = Internal instruction cycle clock (CLKOUT)
- bit 4      **T0SE:** Timer0 Source Edge Select bit  
           1 = Increment on high-to-low transition on T0CKI pin  
           0 = Increment on low-to-high transition on T0CKI pin
- bit 3      **PSA:** Timer0 Prescaler Assignment bit  
           1 = Timer0 prescaler is NOT assigned. Timer0 clock input bypasses prescaler.  
           0 = Timer0 prescaler is assigned. Timer0 clock input comes from prescaler output.
- bit 2-0    **T0PS<2:0>:** Timer0 Prescaler Select bits  
           111 = 1:256 prescale value  
           110 = 1:128 prescale value  
           101 = 1:64 prescale value  
           100 = 1:32 prescale value  
           011 = 1:16 prescale value  
           010 = 1:8 prescale value  
           001 = 1:4 prescale value  
           000 = 1:2 prescale value

# PIC18(L)F1XK22

## 9.1 Timer0 Operation

Timer0 can operate as either a timer or a counter; the mode is selected with the T0CS bit of the T0CON register. In Timer mode (T0CS = 0), the module increments on every clock by default unless a different prescaler value is selected (see [Section 9.3 “Prescaler”](#)). Timer0 incrementing is inhibited for two instruction cycles following a TMR0 register write. The user can work around this by adjusting the value written to the TMR0 register to compensate for the anticipated missing increments.

The Counter mode is selected by setting the T0CS bit (= 1). In this mode, Timer0 increments either on every rising or falling edge of the T0CKI pin. The incrementing edge is determined by the Timer0 Source Edge Select bit, T0SE of the T0CON register; clearing this bit selects the rising edge. Restrictions on the external clock input are discussed below.

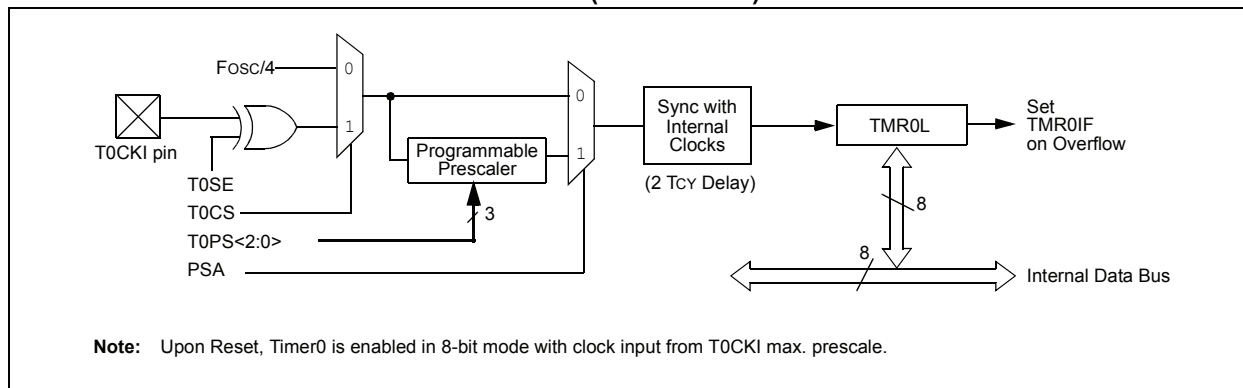
An external clock source can be used to drive Timer0; however, it must meet certain requirements (see [Table 25-6](#)) to ensure that the external clock can be synchronized with the internal phase clock (TOSC). There is a delay between synchronization and the onset of incrementing the timer/counter.

## 9.2 Timer0 Reads and Writes in 16-Bit Mode

TMR0H is not the actual high byte of Timer0 in 16-bit mode; it is actually a buffered version of the real high byte of Timer0 which is neither directly readable nor writable (refer to [Figure 9-2](#)). TMR0H is updated with the contents of the high byte of Timer0 during a read of TMR0L. This provides the ability to read all 16 bits of Timer0 without the need to verify that the read of the high and low byte were valid. Invalid reads could otherwise occur due to a rollover between successive reads of the high and low byte.

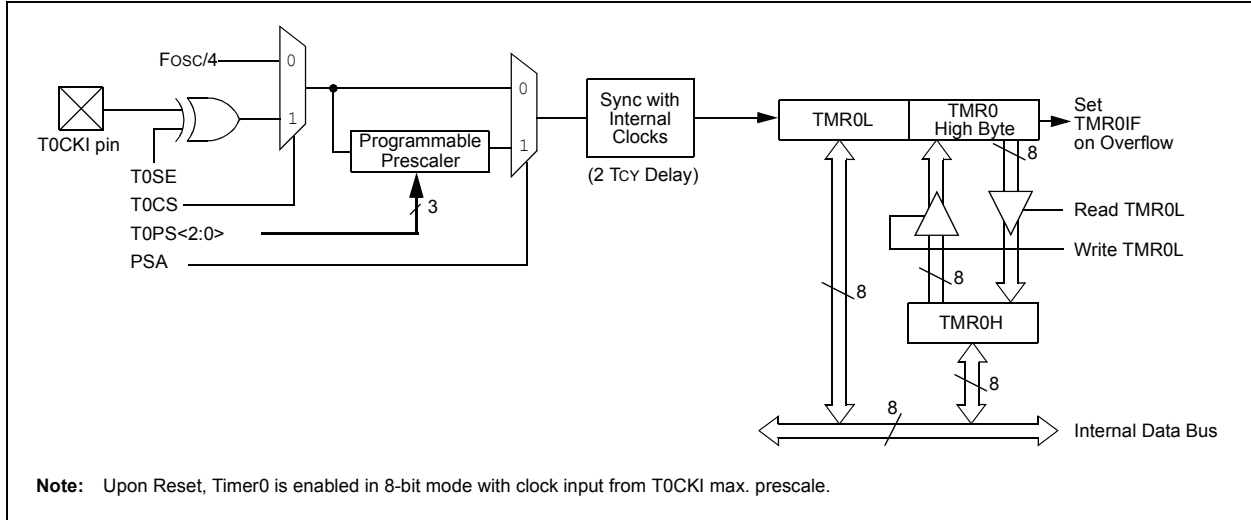
Similarly, a write to the high byte of Timer0 must also take place through the TMR0H Buffer register. Writing to TMR0H does not directly affect Timer0. Instead, the high byte of Timer0 is updated with the contents of TMR0H when a write occurs to TMR0L. This allows all 16 bits of Timer0 to be updated at once.

**FIGURE 9-1: TIMER0 BLOCK DIAGRAM (8-BIT MODE)**





**FIGURE 9-2: TIMER0 BLOCK DIAGRAM (16-BIT MODE)**



## 9.3 Prescaler

An 8-bit counter is available as a prescaler for the Timer0 module. The prescaler is not directly readable or writable; its value is set by the PSA and T0PS<2:0> bits of the T0CON register which determine the prescaler assignment and prescale ratio.

Clearing the PSA bit assigns the prescaler to the Timer0 module. When the prescaler is assigned, prescale values from 1:2 through 1:256 in integer power-of-2 increments are selectable.

When assigned to the Timer0 module, all instructions writing to the TMR0 register (e.g., CLRF TMR0, MOVWF TMR0, BSF TMR0, etc.) clear the prescaler count.

**Note:** Writing to TMR0 when the prescaler is assigned to Timer0 will clear the prescaler count but will not change the prescaler assignment.

### 9.3.1 SWITCHING PRESCALER ASSIGNMENT

The prescaler assignment is fully under software control and can be changed “on-the-fly” during program execution.

## 9.4 Timer0 Interrupt

The TMR0 interrupt is generated when the TMR0 register overflows from FFh to 00h in 8-bit mode, or from FFFFh to 0000h in 16-bit mode. This overflow sets the TMR0IF flag bit. The interrupt can be masked by clearing the TMR0IE bit of the INTCON register. Before re-enabling the interrupt, the TMR0IF bit must be cleared by software in the Interrupt Service Routine.

Since Timer0 is shut down in Sleep mode, the TMR0 interrupt cannot awaken the processor from Sleep.

**TABLE 9-1: REGISTERS ASSOCIATED WITH TIMER0**

Name	Bit 7	Bit 6	Bit 5	Bit 4	Bit 3	Bit 2	Bit 1	Bit 0	Reset Values on page
INTCON	GIE/GIEH	PEIE/GIEL	TMR0IE	INT0IE	RABIE	TMR0IF	INT0IF	RABIF	253
PORTA	RA7	RA6	RA5	RA4	RA3	RA2	RA1	RA0	256
TMR0H	Timer0 Register, High Byte								254
TMR0L	Timer0 Register, Low Byte								254
TRISA	—	—	TRISA5	TRISA4	—	TRISA2	TRISA1	TRISA0	256
T0CON	TMR0ON	T08BIT	T0CS	T0SE	PSA	T0PS2	T0PS1	T0PS0	254

**Legend:** Shaded cells are not used by Timer0.

# PIC18(L)F1XK22

---

NOTES:

## 10.0 TIMER1 MODULE

The Timer1 timer/counter module incorporates the following features:

- Software selectable operation as a 16-bit timer or counter
- Readable and writable 8-bit registers (TMR1H and TMR1L)
- Selectable internal or external clock source and Timer1 oscillator options
- Interrupt-on-overflow
- Reset on CCP Special Event Trigger
- Device clock status flag (T1RUN)

A simplified block diagram of the Timer1 module is shown in [Figure 10-1](#). A block diagram of the module's operation in Read/Write mode is shown in [Figure 10-2](#).

Timer1 can also be used to provide Real-Time Clock (RTC) functionality to applications with only a minimal addition of external components and code overhead.

Timer1 is controlled through the T1CON Control register ([Register 10-1](#)). It also contains the Timer1 Oscillator Enable bit (T1OSCEN). Timer1 can be enabled or disabled by setting or clearing control bit, TMR1ON of the T1CON register.

**REGISTER 10-1: T1CON: TIMER1 CONTROL REGISTER**

R/W-0	R-0	R/W-0	R/W-0	R/W-0	R/W-0	R/W-0	R/W-0
RD16	T1RUN	T1CKPS1	T1CKPS0	T1OSCEN	$\overline{T1SYNC}$	TMR1CS	TMR1ON
bit 7							bit 0

**Legend:**

R = Readable bit	W = Writable bit	U = Unimplemented bit, read as '0'
-n = Value at POR	'1' = Bit is set	'0' = Bit is cleared
		x = Bit is unknown

- bit 7 **RD16:** 16-bit Read/Write Mode Enable bit
  - 1 = Enables register read/write of Timer1 in one 16-bit operation
  - 0 = Enables register read/write of Timer1 in two 8-bit operations
- bit 6 **T1RUN:** Timer1 System Clock Status bit
  - 1 = Main system clock is derived from Timer1 oscillator
  - 0 = Main system clock is derived from another source
- bit 5-4 **T1CKPS<1:0>:** Timer1 Input Clock Prescale Select bits
  - 11 = 1:8 Prescale value
  - 10 = 1:4 Prescale value
  - 01 = 1:2 Prescale value
  - 00 = 1:1 Prescale value
- bit 3 **T1OSCEN:** Timer1 Oscillator Enable bit
  - 1 = Timer1 oscillator is enabled
  - 0 = Timer1 oscillator is shut off

The oscillator inverter and feedback resistor are turned off to eliminate power drain.
- bit 2  **$\overline{T1SYNC}$ :** Timer1 External Clock Input Synchronization Select bit
  - When TMR1CS = 1:
    - 1 = Do not synchronize external clock input
    - 0 = Synchronize external clock input
  - When TMR1CS = 0:
    - This bit is ignored. Timer1 uses the internal clock when TMR1CS = 0.
- bit 1 **TMR1CS:** Timer1 Clock Source Select bit
  - 1 = External clock from the T13CKI pin (on the rising edge)
  - 0 = Internal clock (Fosc/4)
- bit 0 **TMR1ON:** Timer1 On bit
  - 1 = Enables Timer1
  - 0 = Stops Timer1

# PIC18(L)F1XK22

## 10.1 Timer1 Operation

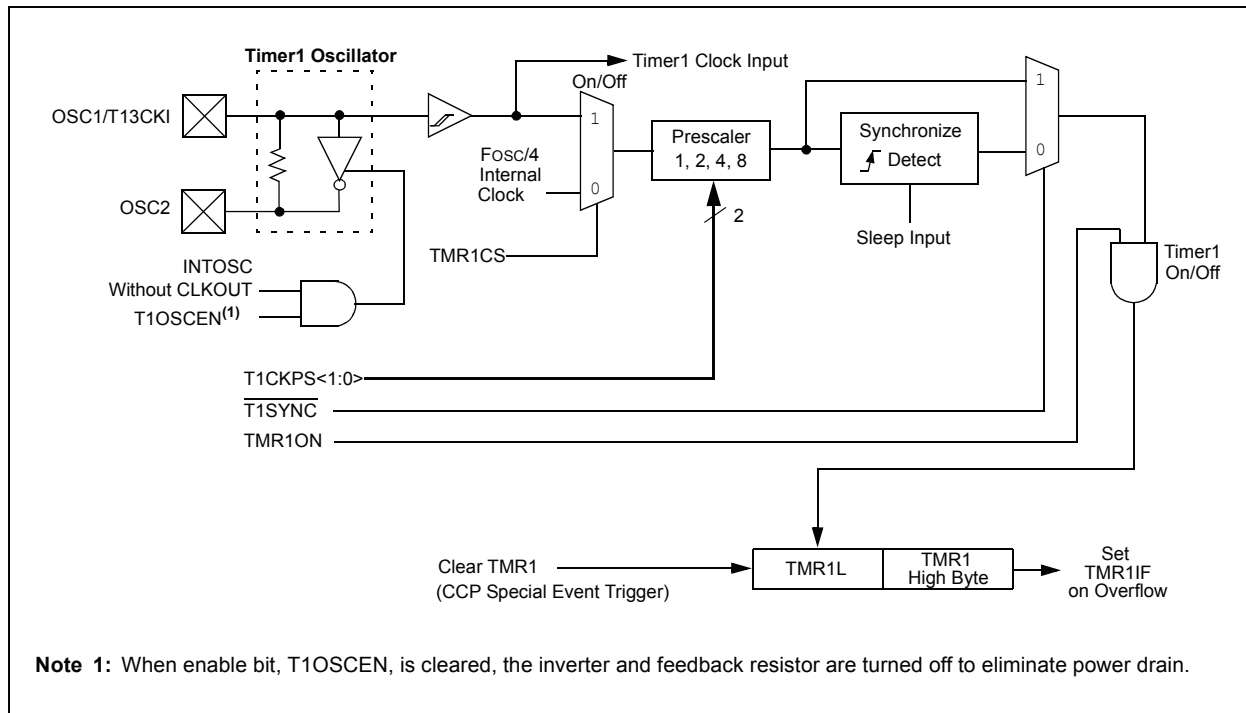
Timer1 can operate in one of the following modes:

- Timer
- Synchronous Counter
- Asynchronous Counter

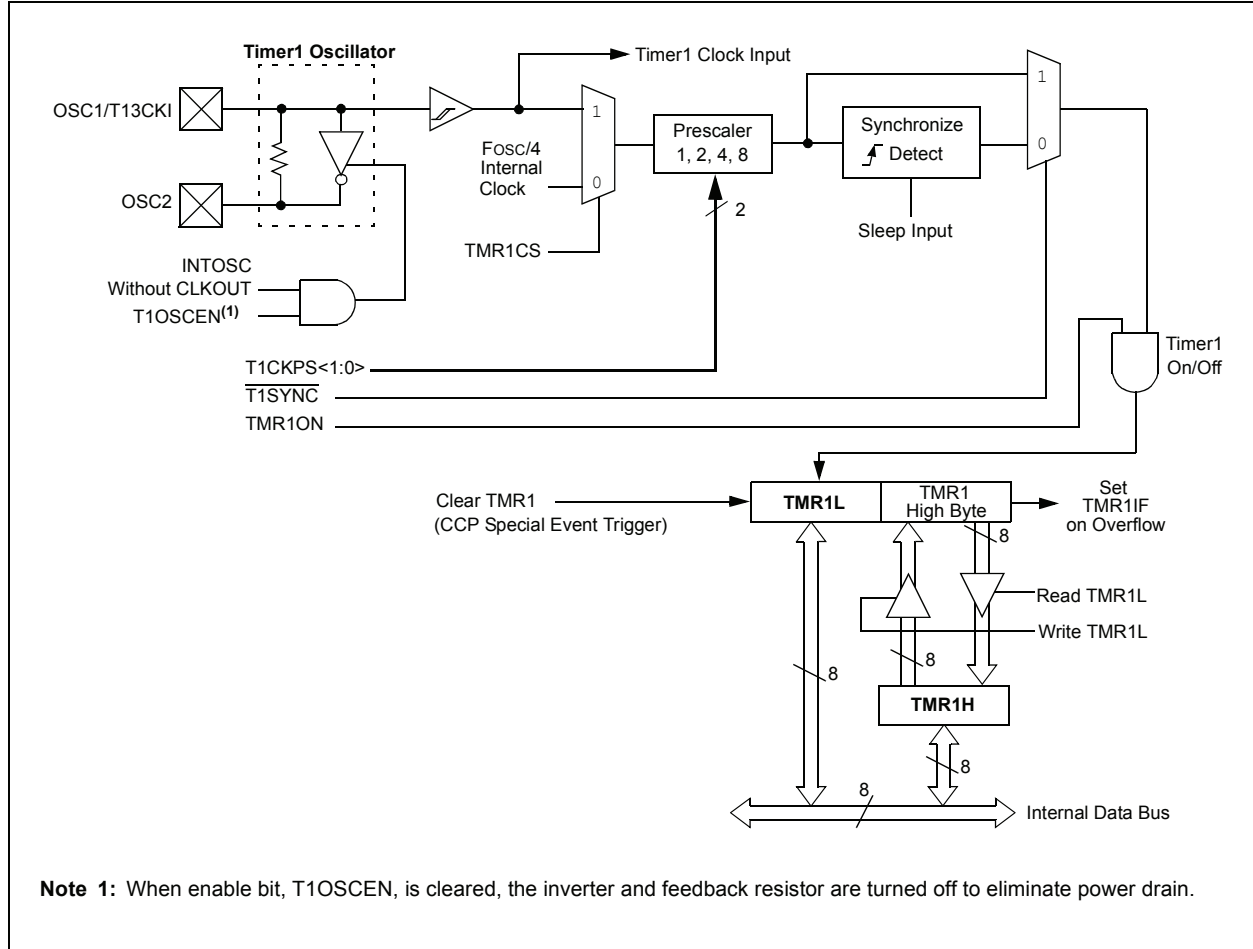
The operating mode is determined by the clock select bit, TMR1CS of the T1CON register. When TMR1CS is cleared (= 0), Timer1 increments on every internal instruction cycle ( $F_{osc}/4$ ). When the bit is set, Timer1 increments on every rising edge of either the Timer1 external clock input or the Timer1 oscillator, if enabled.

When the Timer1 oscillator is enabled, the digital circuitry associated with the OSC1 and OSC2 pins is disabled. This means the values of TRISA<5:4> are ignored and the pins are read as '0'.

**FIGURE 10-1: TIMER1 BLOCK DIAGRAM**



**FIGURE 10-2: TIMER1 BLOCK DIAGRAM (16-BIT READ/WRITE MODE)**



# PIC18(L)F1XK22

## 10.2 Timer1 16-Bit Read/Write Mode

Timer1 can be configured for 16-bit reads and writes (see [Figure 10-2](#)). When the RD16 control bit of the T1CON register is set, the address for TMR1H is mapped to a buffer register for the high byte of Timer1. A read from TMR1L will load the contents of the high byte of Timer1 into the Timer1 high byte buffer. This provides the user with the ability to accurately read all 16 bits of Timer1 without the need to determine whether a read of the high byte, followed by a read of the low byte, has become invalid due to a rollover or carry between reads.

Writing to TMR1H does not directly affect Timer1. Instead, the high byte of Timer1 is updated with the contents of TMR1H when a write occurs to TMR1L. This allows all 16 bits of Timer1 to be updated at once.

The high byte of Timer1 is not directly readable or writable in this mode. All reads and writes must take place through the Timer1 High Byte Buffer register. Writes to TMR1H do not clear the Timer1 prescaler. The prescaler is only cleared on writes to TMR1L.

## 10.3 Clock Source Selection

The TMR1CS bit of the T1CON register is used to select the clock source. When TMR1CS = 0, the clock source is Fosc/4. When TMR1CS = 1, the clock source is supplied externally.

Clock Source	T1OSCN	FOSC Mode	TMR1CS
Fosc/4	x	xxx	0
T1CKI pin	0	xxx	1
T1LPOSC	1	LP or INTOSCIO	1

### 10.3.1 INTERNAL CLOCK SOURCE

When the internal clock source is selected the TMR1H:TMR1L register pair will increment on multiples of Fosc as determined by the Timer1 prescaler.

### 10.3.2 EXTERNAL CLOCK SOURCE

When the external clock source is selected, the Timer1 module may work as a timer or a counter.

When counting, Timer1 is incremented on the rising edge of the external clock input T1CKI. In addition, the Counter mode clock can be synchronized to the microcontroller system clock or run asynchronously.

If an external clock oscillator is needed (and the microcontroller is using the INTOSC without CLKOUT), Timer1 can use the LP oscillator as a clock source.

**Note:** In Counter mode, a falling edge must be registered by the counter prior to the first incrementing rising edge after any one or more of the following conditions:

- Timer1 enabled after POR
- Write to TMR1H or TMR1L
- Timer1 is disabled
- Timer1 is disabled (TMR1ON = 0) when T1CKI is high then Timer1 is enabled (TMR1ON = 1) when T1CKI is low.

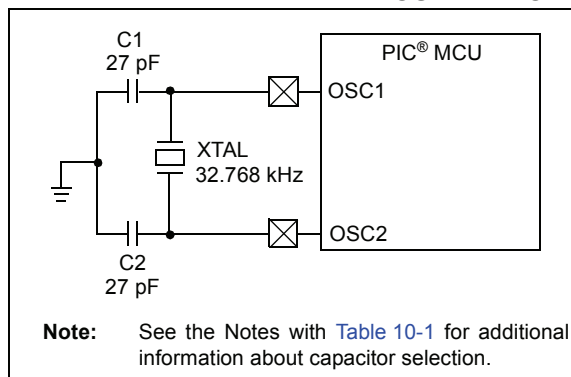
**Note:** See [Figure 9-2](#).

## 10.4 Timer1 Oscillator

An on-chip crystal oscillator circuit is incorporated between pins OSC1 (input) and OSC2 (amplifier output). It is enabled by setting the Timer1 Oscillator Enable bit, T1OSCN of the T1CON register. The oscillator is a low-power circuit rated for 32 kHz crystals. It will continue to run during all power-managed modes. The circuit for a typical LP oscillator is shown in [Figure 10-3](#). [Table 10-1](#) shows the capacitor selection for the Timer1 oscillator.

The Timer1 oscillator is shared with the system LP oscillator. Thus, Timer1 can use this mode only when the primary system clock is derived from the internal oscillator or when the oscillator is in the LP mode. The user must provide a software time delay to ensure proper oscillator start-up.

**FIGURE 10-3: EXTERNAL COMPONENTS FOR THE TIMER1 LP OSCILLATOR**



**TABLE 10-1: CAPACITOR SELECTION FOR THE TIMER OSCILLATOR**

Osc Type	Freq.	C1	C2
LP	32 kHz	27 pF <sup>(1)</sup>	27 pF <sup>(1)</sup>

**Note 1:** Microchip suggests these values only as a starting point in validating the oscillator circuit.

**2:** Higher capacitance increases the stability of the oscillator but also increases the start-up time.

**3:** Since each resonator/crystal has its own characteristics, the user should consult the resonator/crystal manufacturer for appropriate values of external components.

**4:** Capacitor values are for design guidance only.

## 10.5 Timer1 Interrupt

The TMR1 register pair (TMR1H:TMR1L) increments from 0000h to FFFFh and rolls over to 0000h. The Timer1 interrupt, if enabled, is generated on overflow, which is latched in the TMR1IF interrupt flag bit of the PIR1 register. This interrupt can be enabled or disabled by setting or clearing the TMR1IE Interrupt Enable bit of the PIE1 register.

## 10.6 Resetting Timer1 Using the CCP Special Event Trigger

If either of the CCP modules is configured to use Timer1 and generate a Special Event Trigger in Compare mode (CCP1M<3:0> or CCP2M<3:0> = 1011), this signal will reset Timer1. The trigger from CCP2 will also start an A/D conversion if the A/D module is enabled (see [Section 13.3.4 “Special Event Trigger”](#) for more information).

The module must be configured as either a timer or a synchronous counter to take advantage of this feature. When used this way, the CCPRH:CCPRL register pair effectively becomes a period register for Timer1.

If Timer1 is running in Asynchronous Counter mode, this Reset operation may not work.

In the event that a write to Timer1 coincides with a special Event Trigger, the write operation will take precedence.

**Note:** The Special Event Triggers from the CCP2 module will not set the TMR1IF interrupt flag bit of the PIR1 register.

## 10.7 Using Timer1 as a Real-Time Clock

Adding an external LP oscillator to Timer1 (such as the one described in [Section 10.4 “Timer1 Oscillator”](#) above) gives users the option to include RTC functionality to their applications. This is accomplished with an inexpensive watch crystal to provide an accurate time base and several lines of application code to calculate the time. When operating in Sleep mode and using a battery or supercapacitor as a power source, it can completely eliminate the need for a separate RTC device and battery backup.

The application code routine, `RTCisr`, shown in [Example 10-1](#), demonstrates a simple method to increment a counter at one-second intervals using an Interrupt Service Routine. Incrementing the TMR1 register pair to overflow triggers the interrupt and calls the routine, which increments the seconds counter by one; additional counters for minutes and hours are incremented on overflows of the less significant counters.

Since the register pair is 16 bits wide, a 32.768 kHz clock source will take 2 seconds to count up to overflow. To force the overflow at the required one-second intervals, it is necessary to preload it; the simplest method is to set the MSb of TMR1H with a `BSF` instruction. Note that the TMR1L register is never preloaded or altered; doing so may introduce cumulative error over many cycles.

For this method to be accurate, Timer1 must operate in Asynchronous mode and the Timer1 overflow interrupt must be enabled (PIE1<0> = 1), as shown in the routine, `RTCinit`. The Timer1 oscillator must also be enabled and running at all times.

# PIC18(L)F1XK22

## EXAMPLE 10-1: IMPLEMENTING A REAL-TIME CLOCK USING A TIMER1 INTERRUPT SERVICE

```

RTCinit
    MOVLW    80h           ; Preload TMR1 register pair
    MOVWF   TMR1H         ; for 1 second overflow
    CLRF    TMR1L
    MOVLW   b'00001111'   ; Configure for external clock,
    MOVWF   T1CON         ; Asynchronous operation, external oscillator
    CLRF    secs          ; Initialize timekeeping registers
    CLRF    mins          ;
    MOVLW   .12
    MOVWF   hours
    BSF     PIE1, TMR1IE  ; Enable Timer1 interrupt
    RETURN

RTCisr
    BSF     TMR1H, 7      ; Preload for 1 sec overflow
    BCF     PIR1, TMR1IF  ; Clear interrupt flag
    INCF    secs, F       ; Increment seconds
    MOVLW   .59           ; 60 seconds elapsed?
    CPFSGT  secs
    RETURN                ; No, done
    CLRF    secs          ; Clear seconds
    INCF    mins, F       ; Increment minutes
    MOVLW   .59           ; 60 minutes elapsed?
    CPFSGT  mins
    RETURN                ; No, done
    CLRF    mins          ; clear minutes
    INCF    hours, F      ; Increment hours
    MOVLW   .23           ; 24 hours elapsed?
    CPFSGT  hours
    RETURN                ; No, done
    CLRF    hours        ; Reset hours
    RETURN                ; Done
    
```

**TABLE 10-2: REGISTERS ASSOCIATED WITH TIMER1 AS A TIMER/COUNTER**

Name	Bit 7	Bit 6	Bit 5	Bit 4	Bit 3	Bit 2	Bit 1	Bit 0	Reset Values on page
INTCON	GIE/GIEH	PEIE/GIEL	TMR0IE	INT0IE	RABIE	TMR0IF	INT0IF	RABIF	253
IPR1	—	ADIP	RCIP	TXIP	SSPIP	CCP1IP	TMR2IP	TMR1IP	256
PIE1	—	ADIE	RCIE	TXIE	SSPIE	CCP1IE	TMR2IE	TMR1IE	256
PIR1	—	ADIF	RCIF	TXIF	SSPIF	CCP1IF	TMR2IF	TMR1IF	256
TMR1H	Timer1 Register, High Byte								254
TMR1L	Timer1 Register, Low Byte								254
TRISA	—	—	TRISA5	TRISA4	—	TRISA2	TRISA1	TRISA0	256
T1CON	RD16	T1RUN	T1CKPS1	T1CKPS0	T1OSCEN	T1SYN $\bar{C}$	TMR1CS	TMR1ON	254

**Legend:** — = unimplemented, read as '0'. Shaded cells are not used by the Timer1 module.



## 11.0 TIMER2 MODULE

The Timer2 module timer incorporates the following features:

- 8-bit timer and period registers (TMR2 and PR2, respectively)
- Readable and writable (both registers)
- Software programmable prescaler (1:1, 1:4 and 1:16)
- Software programmable postscaler (1:1 through 1:16)
- Interrupt on TMR2-to-PR2 match
- Optional use as the shift clock for the MSSP module

The module is controlled through the T2CON register (Register 11-1), which enables or disables the timer and configures the prescaler and postscaler. Timer2 can be shut off by clearing control bit, TMR2ON of the T2CON register, to minimize power consumption.

A simplified block diagram of the module is shown in Figure 11-1.

## 11.1 Timer2 Operation

In normal operation, TMR2 is incremented from 00h on each clock ( $F_{osc}/4$ ). A 4-bit counter/prescaler on the clock input gives direct input, divide-by-4 and divide-by-16 prescale options; these are selected by the prescaler control bits, T2CKPS<1:0> of the T2CON register. The value of TMR2 is compared to that of the period register, PR2, on each clock cycle. When the two values match, the comparator generates a match signal as the timer output. This signal also resets the value of TMR2 to 00h on the next cycle and drives the output counter/postscaler (see Section 11.2 “Timer2 Interrupt”).

The TMR2 and PR2 registers are both directly readable and writable. The TMR2 register is cleared on any device Reset, whereas the PR2 register initializes to FFh. Both the prescaler and postscaler counters are cleared on the following events:

- a write to the TMR2 register
- a write to the T2CON register
- any device Reset (Power-on Reset,  $\overline{MCLR}$  Reset, Watchdog Timer Reset or Brown-out Reset)

TMR2 is not cleared when T2CON is written.

### REGISTER 11-1: T2CON: TIMER2 CONTROL REGISTER

U-0	R/W-0	R/W-0	R/W-0	R/W-0	R/W-0	R/W-0	R/W-0
—	T2OUTPS3	T2OUTPS2	T2OUTPS1	T2OUTPS0	TMR2ON	T2CKPS1	T2CKPS0
bit 7							bit 0

#### Legend:

R = Readable bit	W = Writable bit	U = Unimplemented bit, read as '0'
-n = Value at POR	'1' = Bit is set	'0' = Bit is cleared
		x = Bit is unknown

bit 7      **Unimplemented:** Read as '0'

bit 6-3    **T2OUTPS<3:0>:** Timer2 Output Postscale Select bits  
 0000 = 1:1 Postscale  
 0001 = 1:2 Postscale  
 •  
 •  
 •  
 1111 = 1:16 Postscale

bit 2      **TMR2ON:** Timer2 On bit  
 1 = Timer2 is on  
 0 = Timer2 is off

bit 1-0    **T2CKPS<1:0>:** Timer2 Clock Prescale Select bits  
 00 = Prescaler is 1  
 01 = Prescaler is 4  
 1x = Prescaler is 16

# PIC18(L)F1XK22

## 11.2 Timer2 Interrupt

Timer2 can also generate an optional device interrupt. The Timer2 output signal (TMR2-to-PR2 match) provides the input for the 4-bit output counter/postscaler. This counter generates the TMR2 match interrupt flag which is latched in TMR2IF of the PIR1 register. The interrupt is enabled by setting the TMR2 Match Interrupt Enable bit, TMR2IE of the PIE1 register.

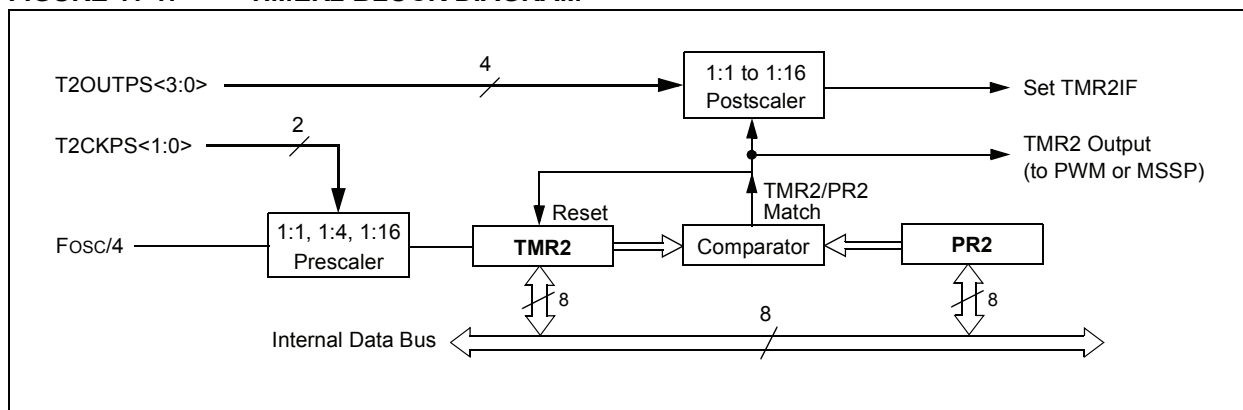
A range of 16 postscale options (from 1:1 through 1:16 inclusive) can be selected with the postscaler control bits, T2OUTPS<3:0> of the T2CON register.

## 11.3 Timer2 Output

The unscaled output of TMR2 is available primarily to the CCP modules, where it is used as a time base for operations in PWM mode.

Timer2 can be optionally used as the shift clock source for the MSSP module operating in SPI mode. Additional information is provided in [Section 14.0 “Master Synchronous Serial Port \(MSSP\) Module”](#).

**FIGURE 11-1: TIMER2 BLOCK DIAGRAM**



**TABLE 11-1: REGISTERS ASSOCIATED WITH TIMER2 AS A TIMER/COUNTER**

Name	Bit 7	Bit 6	Bit 5	Bit 4	Bit 3	Bit 2	Bit 1	Bit 0	Reset Values on page
INTCON	GIE/GIEH	PEIE/GIEL	TMR0IE	INT0IE	RABIE	TMR0IF	INT0IF	RABIF	253
IPR1	—	ADIP	RCIP	TXIP	SSPIP	CCP1IP	TMR2IP	TMR1IP	256
PIE1	—	ADIE	RCIE	TXIE	SSPIE	CCP1IE	TMR2IE	TMR1IE	256
PIR1	—	ADIF	RCIF	TXIF	SSPIF	CCP1IF	TMR2IF	TMR1IF	256
PR2	Timer2 Period Register								254
TMR2	Timer2 Register								254
T2CON	—	T2OUTPS3	T2OUTPS2	T2OUTPS1	T2OUTPS0	TMR2ON	T2CKPS1	T2CKPS0	254

**Legend:** — = unimplemented, read as '0'. Shaded cells are not used by the Timer2 module.

## 12.0 TIMER3 MODULE

The Timer3 module timer/counter incorporates these features:

- Software selectable operation as a 16-bit timer or counter
- Readable and writable 8-bit registers (TMR3H and TMR3L)
- Selectable clock source (internal or external) with device clock or Timer1 oscillator internal options
- Interrupt-on-overflow
- Module Reset on CCP Special Event Trigger

A simplified block diagram of the Timer3 module is shown in [Figure 12-1](#). A block diagram of the module's operation in Read/Write mode is shown in [Figure 12-2](#).

The Timer3 module is controlled through the T3CON register ([Register 12-1](#)). It also selects the clock source options for the CCP modules (see [Section 13.1.1 "CCP Module and Timer Resources"](#) for more information).

**REGISTER 12-1: T3CON: TIMER3 CONTROL REGISTER**

R/W-0	U-0	R/W-0	R/W-0	R/W-0	R/W-0	R/W-0	R/W-0
RD16	—	T3CKPS1	T3CKPS0	T3CCP1	T3SYNC	TMR3CS	TMR3ON
bit 7							bit 0

**Legend:**

R = Readable bit	W = Writable bit	U = Unimplemented bit, read as '0'
-n = Value at POR	'1' = Bit is set	'0' = Bit is cleared
		x = Bit is unknown

- bit 7 **RD16:** 16-bit Read/Write Mode Enable bit
  - 1 = Enables register read/write of Timer3 in one 16-bit operation
  - 0 = Enables register read/write of Timer3 in two 8-bit operations
- bit 6 **Unimplemented:** Read as '0'
- bit 5-4 **T3CKPS<1:0>:** Timer3 Input Clock Prescale Select bits
  - 11 = 1:8 Prescale value
  - 10 = 1:4 Prescale value
  - 01 = 1:2 Prescale value
  - 00 = 1:1 Prescale value
- bit 3 **T3CCP1:** Timer3 and Timer1 to CCP1 Enable bits
  - 1 = Timer3 is the clock source for compare/capture of ECCP1
  - 0 = Timer1 is the clock source for compare/capture of ECCP1
- bit 2 **T3SYNC:** Timer3 External Clock Input Synchronization Control bit (Not usable if the device clock comes from Timer1/Timer3.)
  - When TMR3CS = 1:
    - 1 = Do not synchronize external clock input
    - 0 = Synchronize external clock input
  - When TMR3CS = 0:
    - This bit is ignored. Timer3 uses the internal clock when TMR3CS = 0.
- bit 1 **TMR3CS:** Timer3 Clock Source Select bit
  - 1 = External clock input from Timer1 oscillator or T13CKI (on the rising edge after the first falling edge)
  - 0 = Internal clock (Fosc/4)
- bit 0 **TMR3ON:** Timer3 On bit
  - 1 = Enables Timer3
  - 0 = Stops Timer3

# PIC18(L)F1XK22

## 12.1 Timer3 Operation

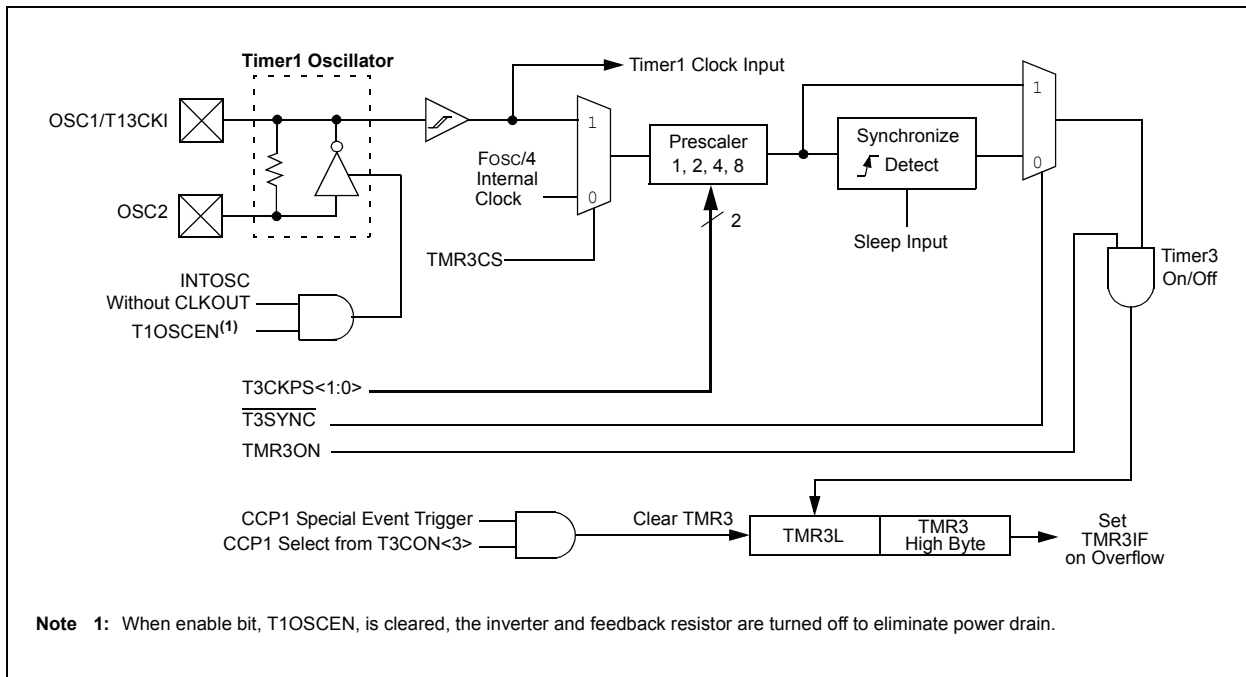
Timer3 can operate in one of three modes:

- Timer
- Synchronous Counter
- Asynchronous Counter

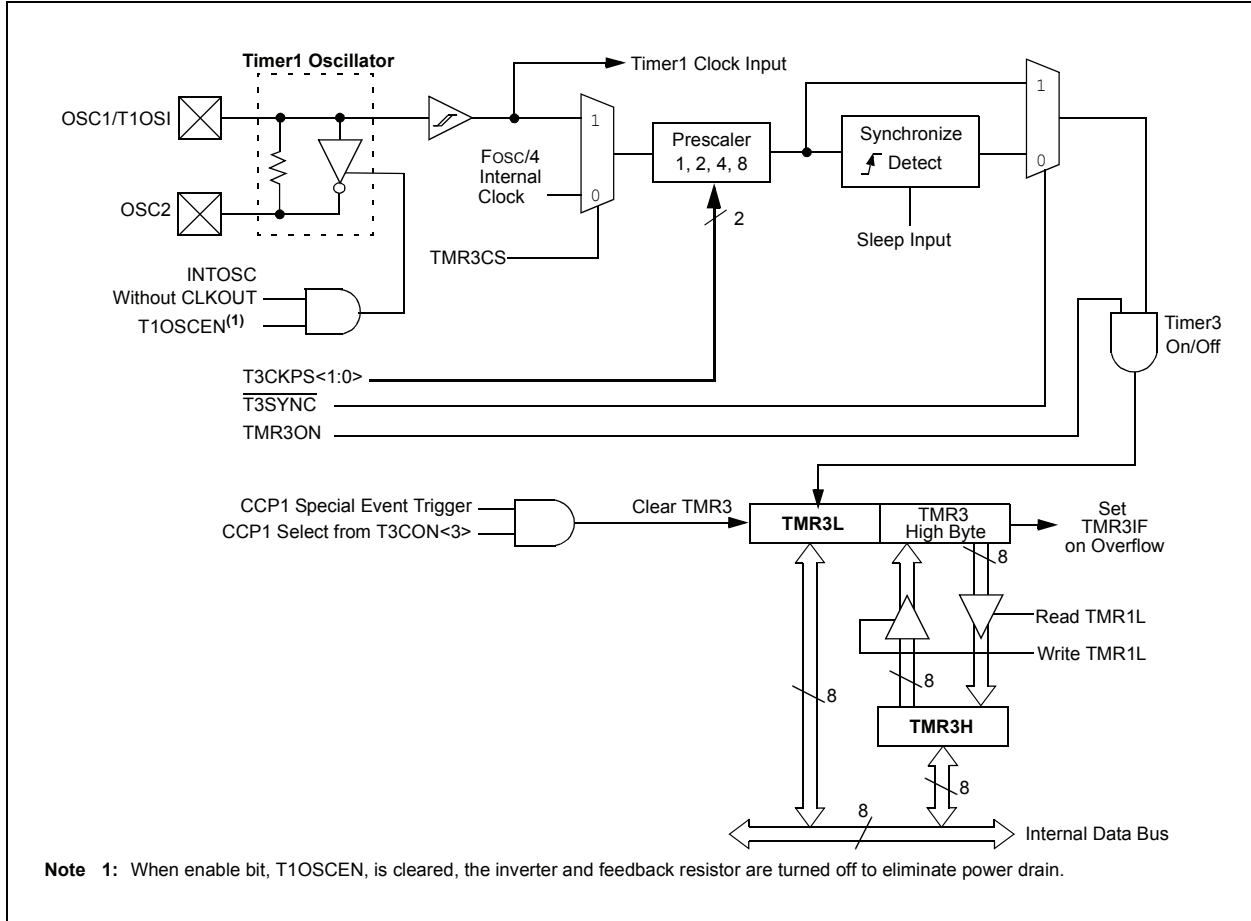
The operating mode is determined by the clock select bit, TMR3CS of the T3CON register. When TMR3CS is cleared (= 0), Timer3 increments on every internal instruction cycle ( $F_{osc}/4$ ). When the bit is set, Timer3 increments on every rising edge of the Timer1 external clock input or the Timer1 oscillator, if enabled.

As with Timer1, the digital circuitry associated with the OSC1 and OSC2 pins is disabled when the Timer1 oscillator is enabled. This means the values of TRISA<5:4> are ignored and the pins are read as '0'.

**FIGURE 12-1: TIMER3 BLOCK DIAGRAM**



**FIGURE 12-2: TIMER3 BLOCK DIAGRAM (16-BIT READ/WRITE MODE)**



# PIC18(L)F1XK22

## 12.2 Timer3 16-Bit Read/Write Mode

Timer3 can be configured for 16-bit reads and writes (see [Figure 12-2](#)). When the RD16 control bit of the T3CON register is set, the address for TMR3H is mapped to a buffer register for the high byte of Timer3. A read from TMR3L will load the contents of the high byte of Timer3 into the Timer3 High Byte Buffer register. This provides the user with the ability to accurately read all 16 bits of Timer1 without having to determine whether a read of the high byte, followed by a read of the low byte, has become invalid due to a rollover between reads.

A write to the high byte of Timer3 must also take place through the TMR3H Buffer register. The Timer3 high byte is updated with the contents of TMR3H when a write occurs to TMR3L. This allows a user to write all 16 bits to both the high and low bytes of Timer3 at once.

The high byte of Timer3 is not directly readable or writable in this mode. All reads and writes must take place through the Timer3 High Byte Buffer register.

Writes to TMR3H do not clear the Timer3 prescaler. The prescaler is only cleared on writes to TMR3L.

## 12.3 Using the Timer1 Oscillator as the Timer3 Clock Source

The Timer1 internal oscillator may be used as the clock source for Timer3. The Timer1 oscillator is enabled by setting the T1OSCEN bit of the T1CON register. To use it as the Timer3 clock source, the TMR3CS bit must also be set. As previously noted, this also configures Timer3 to increment on every rising edge of the oscillator source.

The Timer1 oscillator is described in [Section 10.0 “Timer1 Module”](#).

## 12.4 Timer3 Interrupt

The TMR3 register pair (TMR3H:TMR3L) increments from 0000h to FFFFh and overflows to 0000h. The Timer3 interrupt, if enabled, is generated on overflow and is latched in interrupt flag bit, TMR3IF of the PIR2 register. This interrupt can be enabled or disabled by setting or clearing the Timer3 Interrupt Enable bit, TMR3IE of the PIE2 register.

## 12.5 Resetting Timer3 Using the CCP Special Event Trigger

If CCP1 module is configured to use Timer3 and to generate a Special Event Trigger in Compare mode (CCP1M<3:0>), this signal will reset Timer3. It will also start an A/D conversion if the A/D module is enabled (see [Section 16.2.8 “Special Event Trigger”](#) for more information).

The module must be configured as either a timer or synchronous counter to take advantage of this feature. When used this way, the CCPR1H:CCPR1L register pair effectively becomes a period register for Timer3.

If Timer3 is running in Asynchronous Counter mode, the Reset operation may not work.

In the event that a write to Timer3 coincides with a Special Event Trigger from a CCP module, the write will take precedence.

**TABLE 12-1: REGISTERS ASSOCIATED WITH TIMER3 AS A TIMER/COUNTER**

Name	Bit 7	Bit 6	Bit 5	Bit 4	Bit 3	Bit 2	Bit 1	Bit 0	Reset Values on page
INTCON	GIE/GIEH	PEIE/GIEL	TMR0IE	INT0IE	RABIE	TMR0IF	INT0IF	RABIF	<a href="#">253</a>
IPR2	OSCFIP	C1IP	C2IP	EEIP	BCLIP	—	TMR3IP	—	<a href="#">256</a>
PIE2	OSCFIE	C1IE	C2IE	EEIE	BCLIE	—	TMR3IE	—	<a href="#">256</a>
PIR2	OSCFIF	C1IF	C2IF	EEIF	BCLIF	—	TMR3IF	—	<a href="#">256</a>
TMR3H	Timer3 Register, High Byte								<a href="#">255</a>
TMR3L	Timer3 Register, Low Byte								<a href="#">255</a>
TRISA	—	—	TRISA5	TRISA4	—	TRISA2	TRISA1	TRISA0	<a href="#">256</a>
T1CON	RD16	T1RUN	T1CKPS1	T1CKPS0	T1OSCEN	T1SYNC	TMR1CS	TMR1ON	<a href="#">254</a>
T3CON	RD16	—	T3CKPS1	T3CKPS0	T3CCP1	T3SYNC	TMR3CS	TMR3ON	<a href="#">255</a>

**Legend:** — = unimplemented, read as ‘0’. Shaded cells are not used by the Timer3 module.

## 13.0 ENHANCED CAPTURE/COMPARE/PWM (ECCP) MODULE

PIC18(L)F1XK22 devices have one ECCP (Capture/Compare/PWM) module. The module contains a 16-bit register which can operate as a 16-bit Capture register, a 16-bit Compare register or a PWM Master/Slave Duty Cycle register.

CCP1 is implemented as a standard CCP module with enhanced PWM capabilities. These include:

- Provision for 2 or 4 output channels
- Output steering
- Programmable polarity
- Programmable dead-band control
- Automatic shutdown and restart

The enhanced features are discussed in detail in [Section 13.4 “PWM \(Enhanced Mode\)”](#).

**REGISTER 13-1: CCP1CON: ENHANCED CAPTURE/COMPARE/PWM CONTROL REGISTER**

R/W-0	R/W-0	R/W-0	R/W-0	R/W-0	R/W-0	R/W-0	R/W-0
P1M1	P1M0	DC1B1	DC1B0	CCP1M3	CCP1M2	CCP1M1	CCP1M0
bit 7							bit 0

**Legend:**

R = Readable bit	W = Writable bit	U = Unimplemented bit, read as '0'
-n = Value at POR	'1' = Bit is set	'0' = Bit is cleared      x = Bit is unknown

- bit 7-6      **P1M<1:0>**: Enhanced PWM Output Configuration bits  
If CCP1M<3:2> = 00, 01, 10:  
 xx = P1A assigned as Capture/Compare input/output; P1B, P1C, P1D assigned as port pins  
If CCP1M<3:2> = 11:  
 00 = Single output: P1A, P1B, P1C and P1D controlled by steering (See [Section 13.4.7 “Pulse Steering Mode”](#)).  
 01 = Full-bridge output forward: P1D modulated; P1A active; P1B, P1C inactive  
 10 = Half-bridge output: P1A, P1B modulated with dead-band control; P1C, P1D assigned as port pins  
 11 = Full-bridge output reverse: P1B modulated; P1C active; P1A, P1D inactive
- bit 5-4      **DC1B<1:0>**: PWM Duty Cycle bit 1 and bit 0  
Capture mode:  
 Unused.  
Compare mode:  
 Unused.  
PWM mode:  
 These bits are the two LSBs of the 10-bit PWM duty cycle. The eight MSBs of the duty cycle are found in CCPR1L.
- bit 3-0      **CCP1M<3:0>**: Enhanced CCP Mode Select bits  
 0000 = Capture/Compare/PWM off (resets ECCP module)  
 0001 = Reserved  
 0010 = Compare mode, toggle output on match  
 0011 = Reserved  
 0100 = Capture mode, every falling edge  
 0101 = Capture mode, every rising edge  
 0110 = Capture mode, every 4th rising edge  
 0111 = Capture mode, every 16th rising edge  
 1000 = Compare mode, initialize CCP1 pin low, set output on compare match (set CCP1IF)  
 1001 = Compare mode, initialize CCP1 pin high, clear output on compare match (set CCP1IF)  
 1010 = Compare mode, generate software interrupt only, CCP1 pin reverts to I/O state  
 1011 = Compare mode, trigger special event (ECCP resets TMR1 or TMR3, start A/D conversion, sets CC1IF bit)  
 1100 = PWM mode; P1A, P1C active-high; P1B, P1D active-high  
 1101 = PWM mode; P1A, P1C active-high; P1B, P1D active-low  
 1110 = PWM mode; P1A, P1C active-low; P1B, P1D active-high  
 1111 = PWM mode; P1A, P1C active-low; P1B, P1D active-low

# PIC18(L)F1XK22

In addition to the expanded range of modes available through the CCP1CON register and ECCP1AS register, the ECCP module has two additional registers associated with Enhanced PWM operation and auto-shutdown features. They are:

- PWM1CON (Dead-band delay)
- PSTRCON (output steering)

## 13.1 ECCP Outputs and Configuration

The enhanced CCP module may have up to four PWM outputs, depending on the selected operating mode. These outputs, designated P1A through P1D, are multiplexed with I/O pins on PORTC. The outputs that are active depend on the CCP operating mode selected. The pin assignments are summarized in [Table 13-2](#).

To configure the I/O pins as PWM outputs, the proper PWM mode must be selected by setting the P1M<1:0> and CCP1M<3:0> bits. The appropriate TRISC direction bits for the port pins must also be set as outputs.

### 13.1.1 CCP MODULE AND TIMER RESOURCES

The CCP modules utilize Timers 1, 2 or 3, depending on the mode selected. Timer1 and Timer3 are available to modules in Capture or Compare modes, while Timer2 is available for modules in PWM mode.

**TABLE 13-1: CCP MODE – TIMER RESOURCE**

CCP/ECCP Mode	Timer Resource
Capture	Timer1 or Timer3
Compare	Timer1 or Timer3
PWM	Timer2

The assignment of a particular timer to a module is determined by the Timer-to-CCP enable bits in the T3CON register ([Register 12-1](#)). The interactions between the two modules are summarized in [Figure 13-1](#). In Asynchronous Counter mode, the capture operation will not work reliably.

## 13.2 Capture Mode

In Capture mode, the CCPR1H:CCPR1L register pair captures the 16-bit value of the TMR1 or TMR3 registers when an event occurs on the corresponding CCP1 pin. An event is defined as one of the following:

- every falling edge
- every rising edge
- every 4th rising edge
- every 16th rising edge

The event is selected by the mode select bits, CCP1M<3:0> of the CCP1CON register. When a capture is made, the interrupt request flag bit, CCP1IF, is set; it must be cleared by software. If another capture occurs before the value in register CCPR1 is read, the old captured value is overwritten by the new captured value.

### 13.2.1 CCP PIN CONFIGURATION

In Capture mode, the appropriate CCP1 pin should be configured as an input by setting the corresponding TRIS direction bit.

**Note:** If the CCP1 pin is configured as an output, a write to the port can cause a capture condition.

### 13.2.2 TIMER1/TIMER3 MODE SELECTION

The timers that are to be used with the capture feature (Timer1 and/or Timer3) must be running in Timer mode or Synchronized Counter mode. In Asynchronous Counter mode, the capture operation may not work. The timer to be used with each CCP module is selected in the T3CON register (see [Section 13.1.1 “CCP Module and Timer Resources”](#)).

### 13.2.3 SOFTWARE INTERRUPT

When the Capture mode is changed, a false capture interrupt may be generated. The user should keep the CCP1IE interrupt enable bit clear to avoid false interrupts. The interrupt flag bit, CCP1IF, should also be cleared following any such change in operating mode.



## 13.2.4 CCP PRESCALER

There are four prescaler settings in Capture mode; they are specified as part of the operating mode selected by the mode select bits (CCP1M<3:0>). Whenever the CCP module is turned off or Capture mode is disabled, the prescaler counter is cleared. This means that any Reset will clear the prescaler counter.

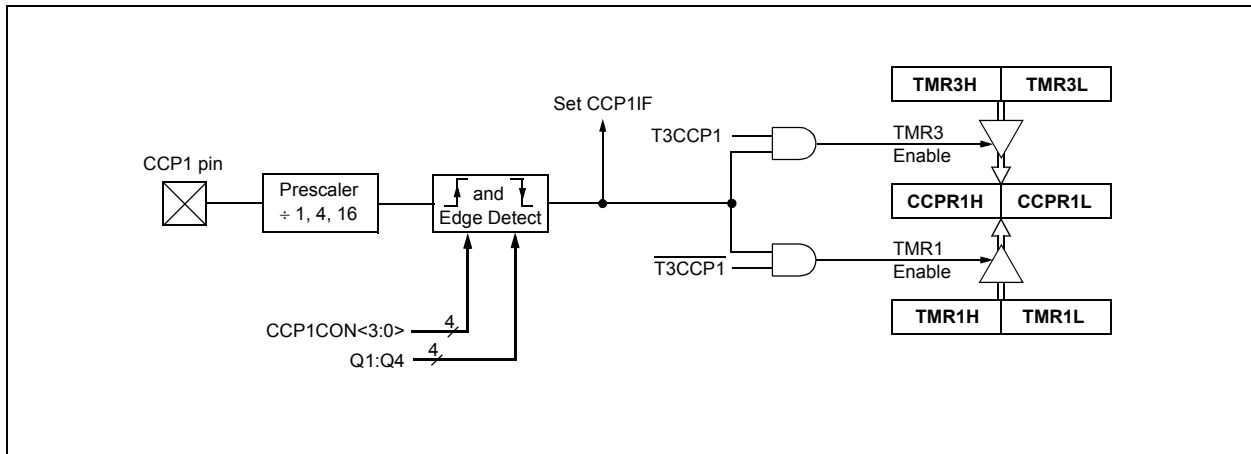
Switching from one capture prescaler to another may generate an interrupt. Also, the prescaler counter will not be cleared; therefore, the first capture may be from a non-zero prescaler. [Example 13-1](#) shows the recommended method for switching between capture prescalers. This example also clears the prescaler counter and will not generate the “false” interrupt.

### EXAMPLE 13-1: CHANGING BETWEEN CAPTURE PRESCALERS

```

CLRF  CCP1CON    ; Turn CCP module off
MOVLW NEW_CAPT_PS ; Load WREG with the
                  ; new prescaler mode
                  ; value and CCP ON
MOVWF  CCP1CON    ; Load CCP1CON with
                  ; this value
    
```

**FIGURE 13-1: CAPTURE MODE OPERATION BLOCK DIAGRAM**



# PIC18(L)F1XK22

## 13.3 Compare Mode

In Compare mode, the 16-bit CCPR1 register value is constantly compared against either the TMR1 or TMR3 register pair value. When a match occurs, the CCP1 pin can be:

- driven high
- driven low
- toggled (high-to-low or low-to-high)
- remain unchanged (that is, reflects the state of the I/O latch)

The action on the pin is based on the value of the mode select bits (CCP1M<3:0>). At the same time, the interrupt flag bit, CCP1IF, is set.

### 13.3.1 CCP PIN CONFIGURATION

The user must configure the CCP1 pin as an output by clearing the appropriate TRIS bit.

**Note:** Clearing the CCP1CON register will force the CCP1 compare output latch (depending on device configuration) to the default low level. This is not the PORTC I/O DATA latch.

### 13.3.2 TIMER1/TIMER3 MODE SELECTION

Timer1 and/or Timer3 must be running in Timer mode or Synchronized Counter mode if the CCP module is using the compare feature. In Asynchronous Counter mode, the compare operation will not work reliably.

### 13.3.3 SOFTWARE INTERRUPT MODE

When the Generate Software Interrupt mode is chosen (CCP1M<3:0> = 1010), the CCP1 pin is not affected. Only the CCP1IF interrupt flag is affected.

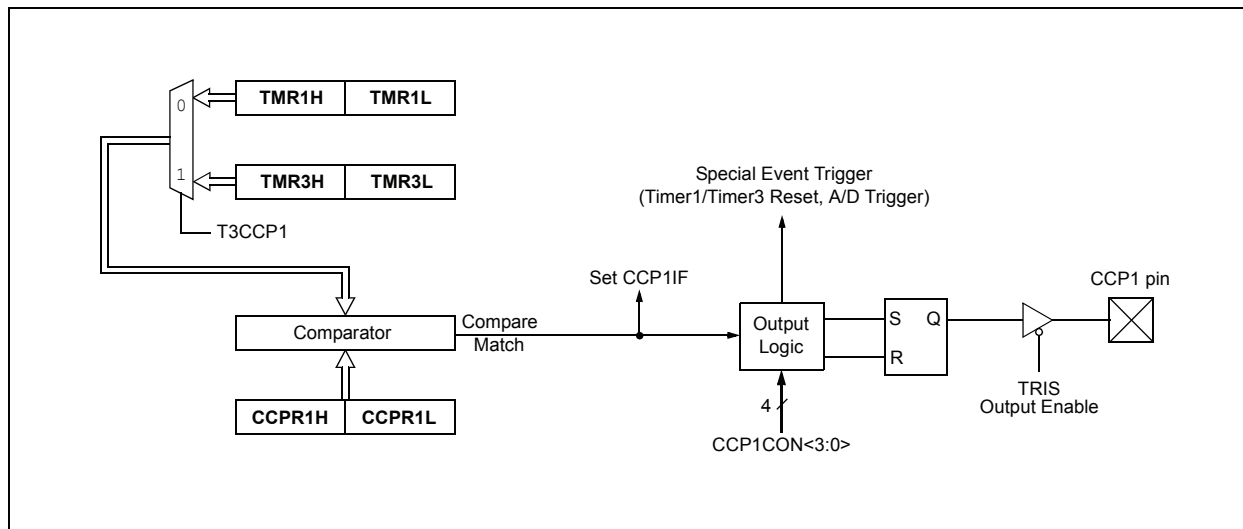
### 13.3.4 SPECIAL EVENT TRIGGER

The CCP module is equipped with a Special Event Trigger. This is an internal hardware signal generated in Compare mode to trigger actions by other modules. The Special Event Trigger is enabled by selecting the Compare Special Event Trigger mode (CCP1M<3:0> = 1011).

The Special Event Trigger resets the timer register pair for whichever timer resource is currently assigned as the module's time base. This allows the CCPR1 registers to serve as a programmable period register for either timer.

The Special Event Trigger can also start an A/D conversion. In order to do this, the A/D converter must already be enabled.

FIGURE 13-2: COMPARE MODE OPERATION BLOCK DIAGRAM



## 13.4 PWM (Enhanced Mode)

The Enhanced PWM mode can generate a PWM signal on up to four different output pins with up to 10-bits of resolution. It can do this through four different PWM output modes:

- Single PWM
- Half-Bridge PWM
- Full-Bridge PWM, Forward mode
- Full-Bridge PWM, Reverse mode

To select an Enhanced PWM mode, the P1M bits of the CCP1CON register must be set appropriately.

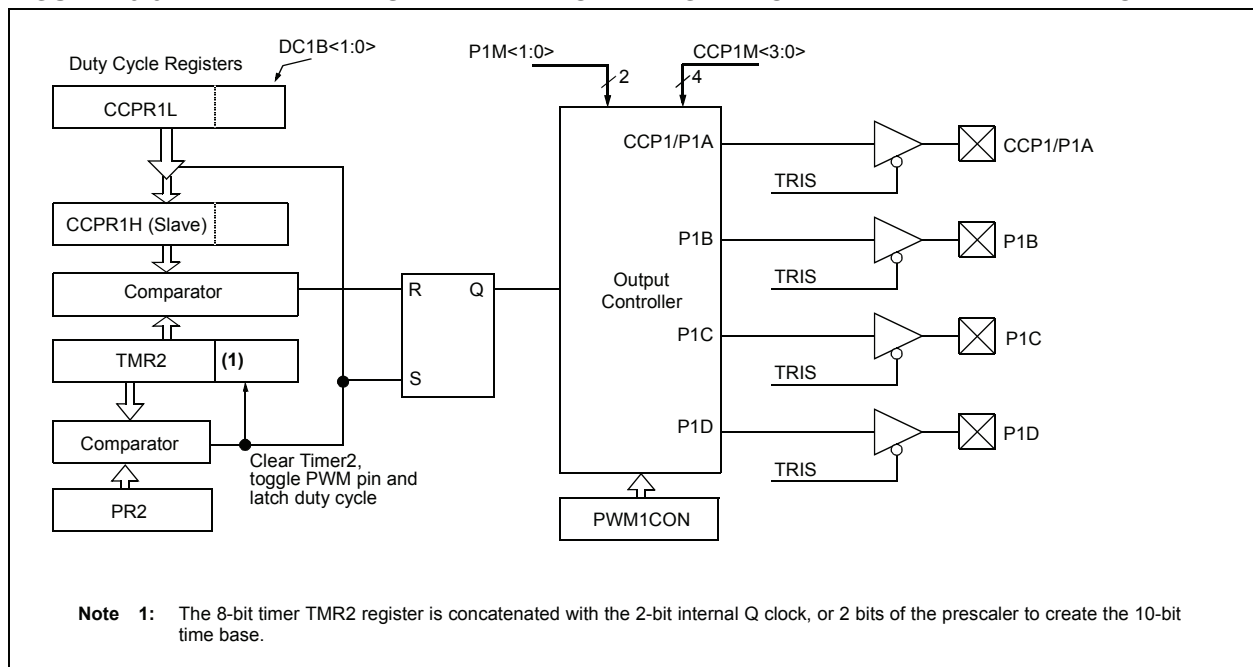
The PWM outputs are multiplexed with I/O pins and are designated P1A, P1B, P1C and P1D. The polarity of the PWM pins is configurable and is selected by setting the CCP1M bits in the CCP1CON register appropriately.

Table 13-1 shows the pin assignments for each Enhanced PWM mode.

Figure 13-3 shows an example of a simplified block diagram of the Enhanced PWM module.

**Note:** To prevent the generation of an incomplete waveform when the PWM is first enabled, the ECCP module waits until the start of a new PWM period before generating a PWM signal.

**FIGURE 13-3: EXAMPLE SIMPLIFIED BLOCK DIAGRAM OF THE ENHANCED PWM MODE**



**Note 1:** The TRIS register value for each PWM output must be configured appropriately.

**Note 2:** Any pin not used by an Enhanced PWM mode is available for alternate pin functions.

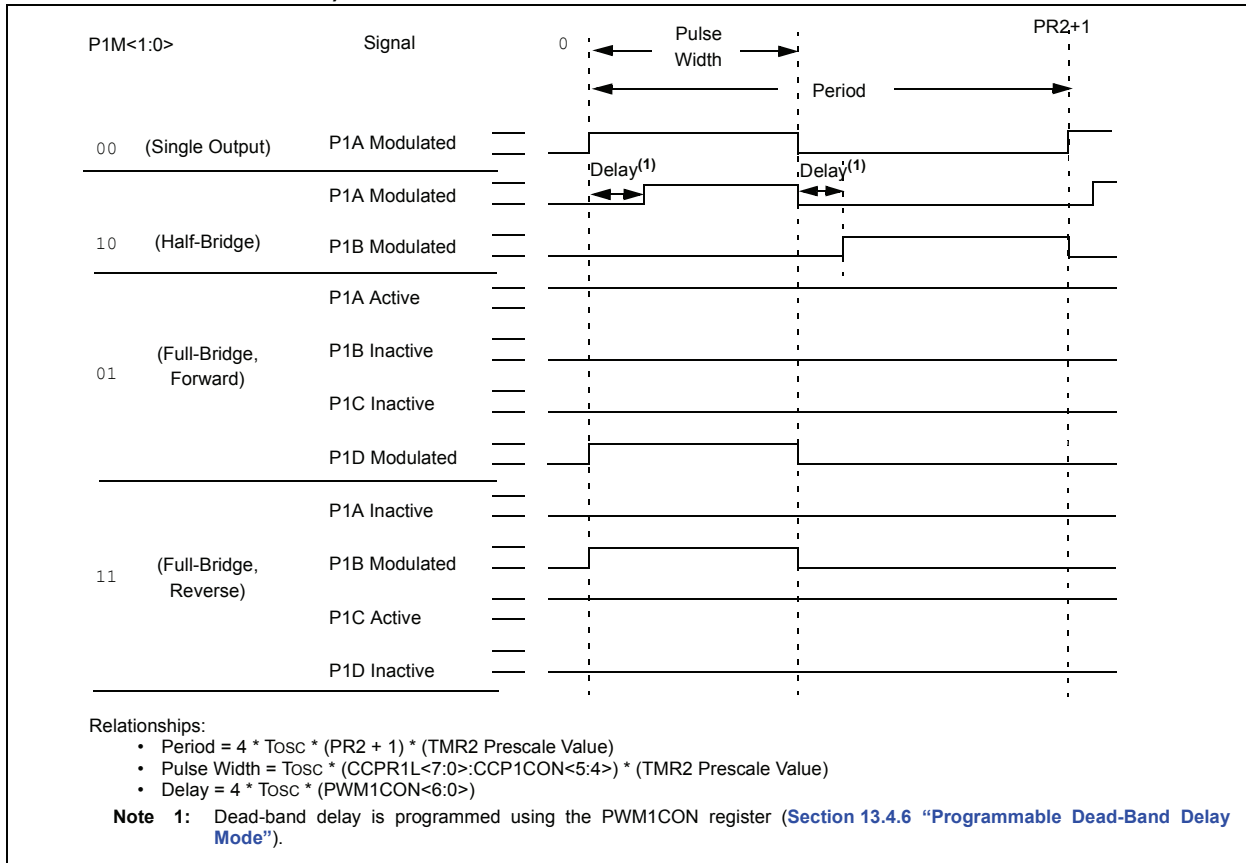
**TABLE 13-2: EXAMPLE PIN ASSIGNMENTS FOR VARIOUS PWM ENHANCED MODES**

ECCP Mode	P1M<1:0>	CCP1/P1A	P1B	P1C	P1D
Single	00	Yes <sup>(1)</sup>	Yes <sup>(1)</sup>	Yes <sup>(1)</sup>	Yes <sup>(1)</sup>
Half-Bridge	10	Yes	Yes	No	No
Full-Bridge, Forward	01	Yes	Yes	Yes	Yes
Full-Bridge, Reverse	11	Yes	Yes	Yes	Yes

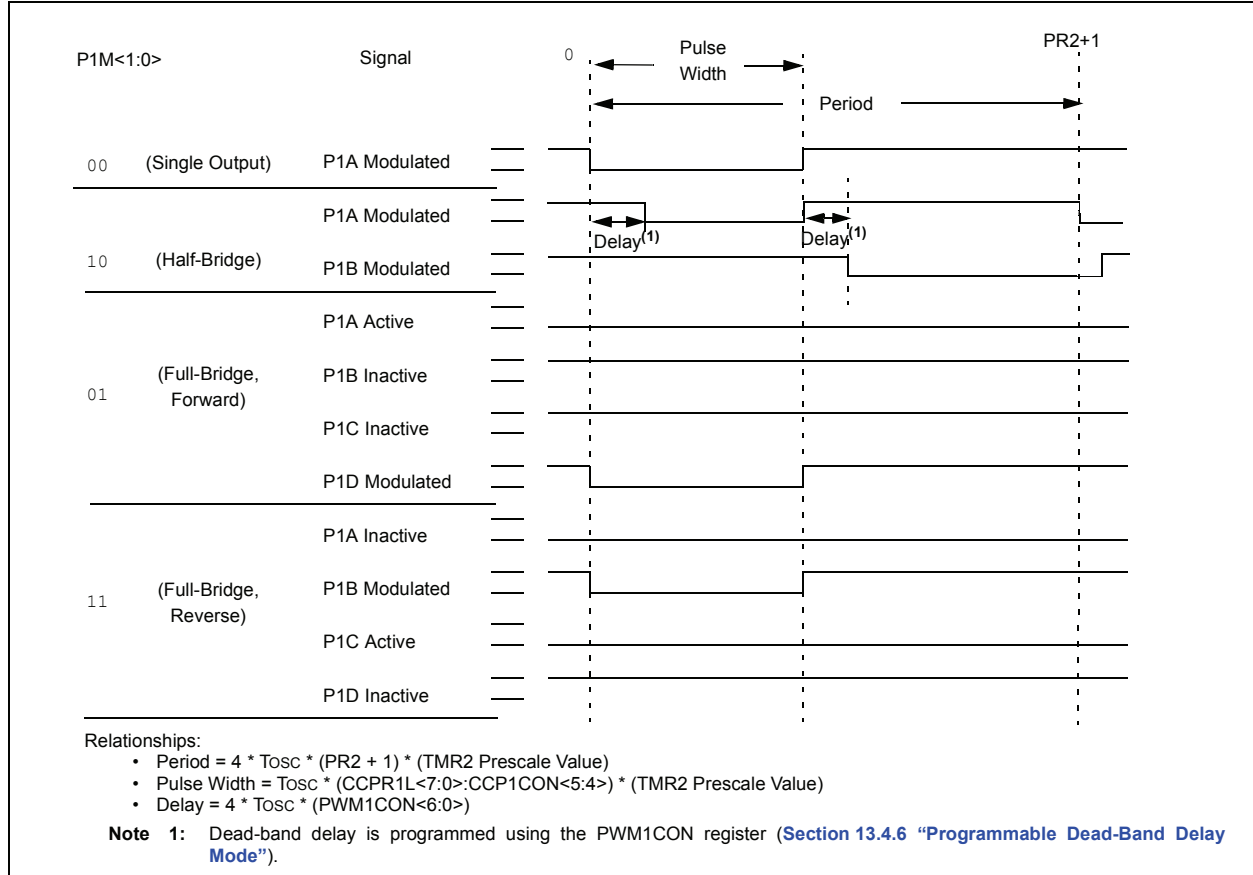
**Note 1:** Outputs are enabled by pulse steering in Single mode. See Register 13-4.

# PIC18(L)F1XK22

**FIGURE 13-4: EXAMPLE PWM (ENHANCED MODE) OUTPUT RELATIONSHIPS (ACTIVE-HIGH STATE)**



**FIGURE 13-5: EXAMPLE ENHANCED PWM OUTPUT RELATIONSHIPS (ACTIVE-LOW STATE)**



# PIC18(L)F1XK22

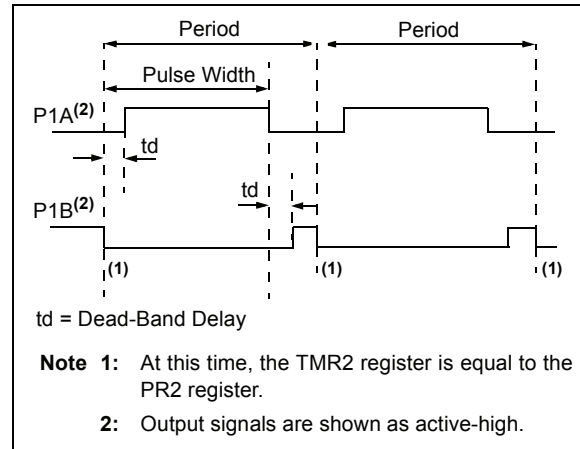
## 13.4.1 HALF-BRIDGE MODE

In Half-Bridge mode, two pins are used as outputs to drive push-pull loads. The PWM output signal is output on the CCP1/P1A pin, while the complementary PWM output signal is output on the P1B pin (see Figure 13-6). This mode can be used for Half-Bridge applications, as shown in Figure 13-7, or for Full-Bridge applications, where four power switches are being modulated with two PWM signals.

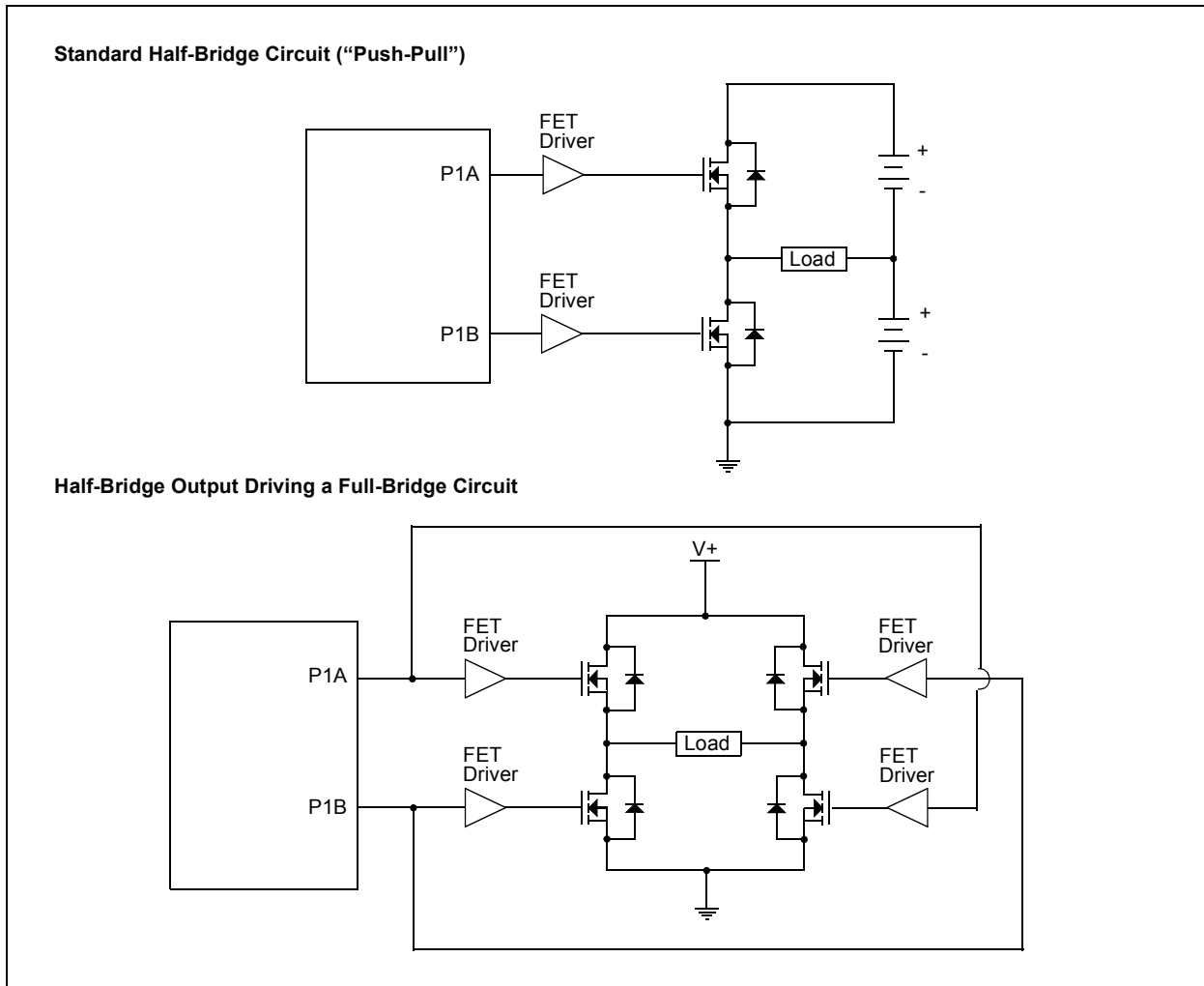
In Half-Bridge mode, the programmable dead-band delay can be used to prevent shoot-through current in Half-Bridge power devices. The value of the PDC<6:0> bits of the PWM1CON register sets the number of instruction cycles before the output is driven active. If the value is greater than the duty cycle, the corresponding output remains inactive during the entire cycle. See Section 13.4.6 “Programmable Dead-Band Delay Mode” for more details of the dead-band delay operations.

Since the P1A and P1B outputs are multiplexed with the PORT data latches, the associated TRIS bits must be cleared to configure P1A and P1B as outputs.

**FIGURE 13-6: EXAMPLE OF HALF-BRIDGE PWM OUTPUT**



**FIGURE 13-7: EXAMPLE OF HALF-BRIDGE APPLICATIONS**



## 13.4.2 FULL-BRIDGE MODE

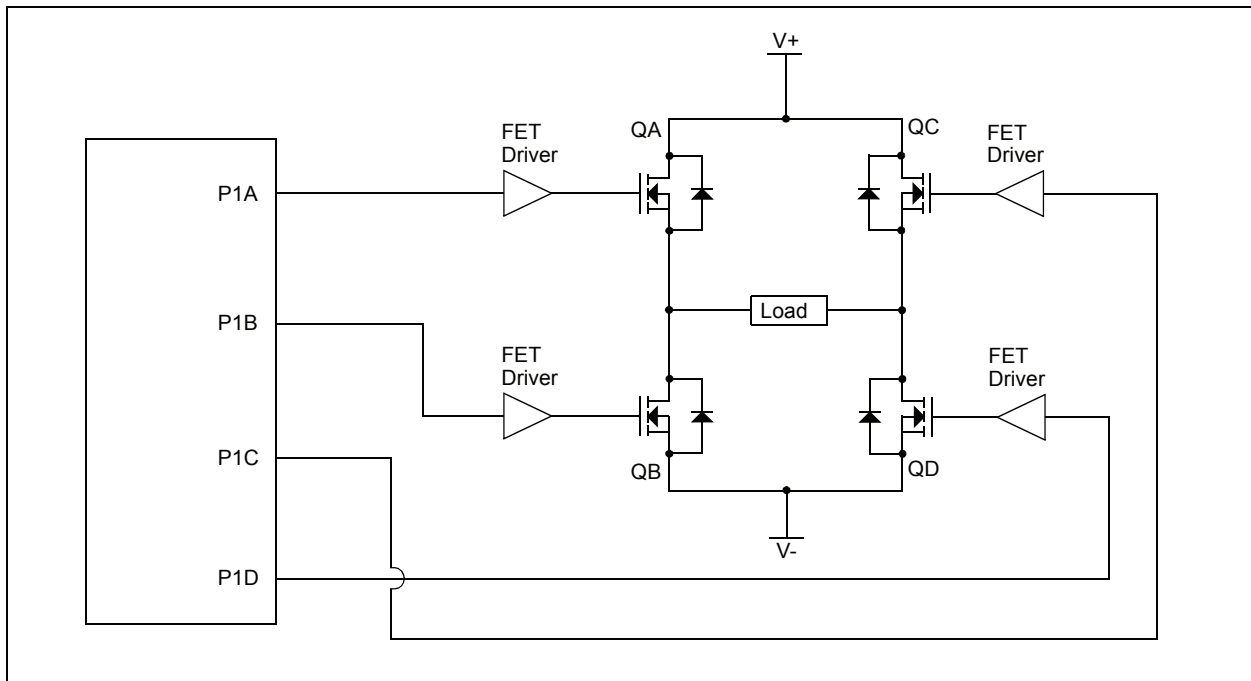
In Full-Bridge mode, all four pins are used as outputs. An example of Full-Bridge application is shown in Figure 13-8.

In the Forward mode, pin CCP1/P1A is driven to its active state, pin P1D is modulated, while P1B and P1C will be driven to their inactive state as shown in Figure 13-9.

In the Reverse mode, P1C is driven to its active state, pin P1B is modulated, while P1A and P1D will be driven to their inactive state as shown Figure 13-9.

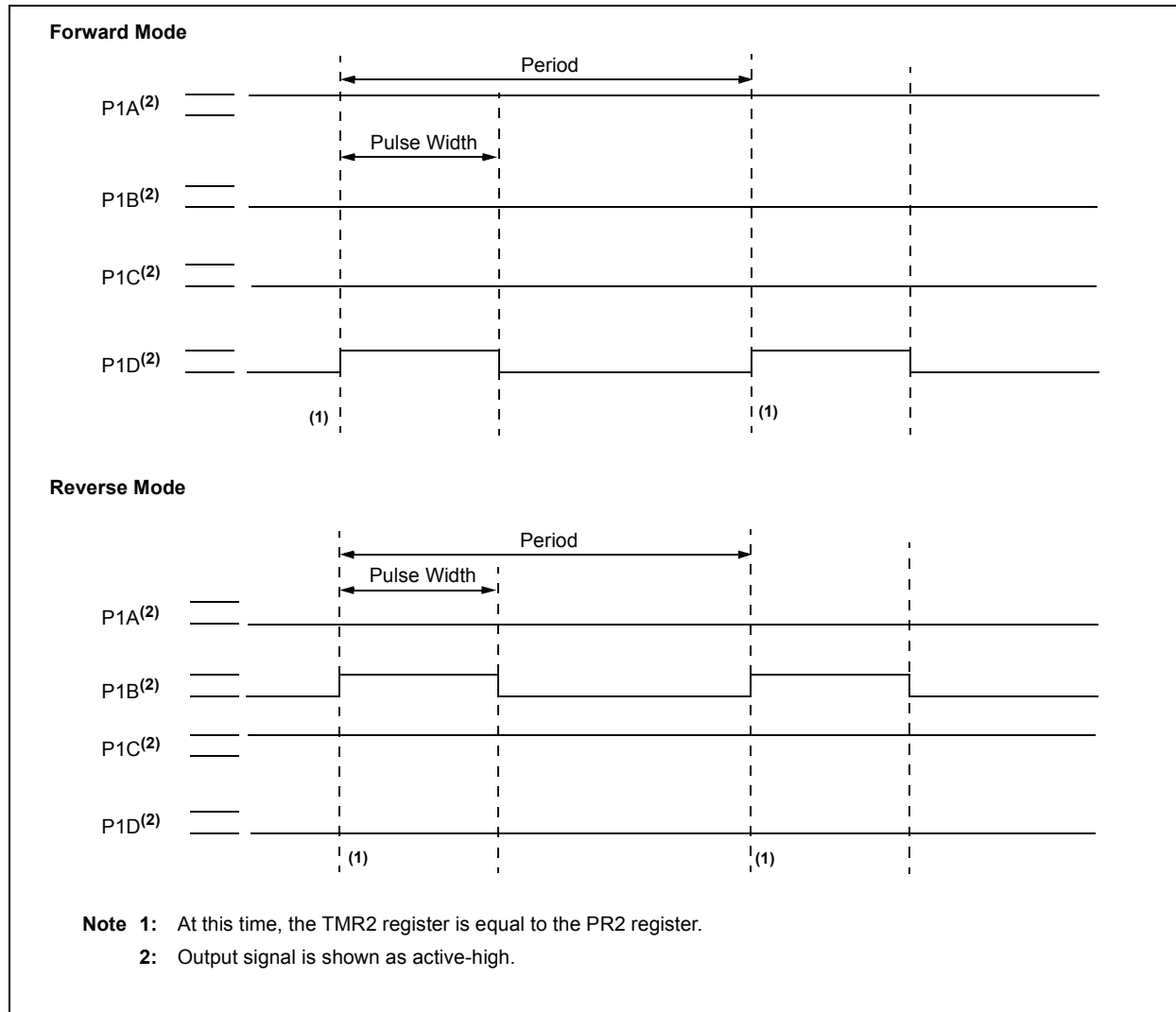
P1A, P1B, P1C and P1D outputs are multiplexed with the PORT data latches. The associated TRIS bits must be cleared to configure the P1A, P1B, P1C and P1D pins as outputs.

**FIGURE 13-8: EXAMPLE OF FULL-BRIDGE APPLICATION**



# PIC18(L)F1XK22

FIGURE 13-9: EXAMPLE OF FULL-BRIDGE PWM OUTPUT





## 13.4.2.1 Direction Change in Full-Bridge Mode

In the Full-Bridge mode, the P1M1 bit in the CCP1CON register allows users to control the forward/reverse direction. When the application firmware changes this direction control bit, the module will change to the new direction on the next PWM cycle.

A direction change is initiated in software by changing the P1M1 bit of the CCP1CON register. The following sequence occurs prior to the end of the current PWM period:

- The modulated outputs (P1B and P1D) are placed in their inactive state.
- The associated unmodulated outputs (P1A and P1C) are switched to drive in the opposite direction.
- PWM modulation resumes at the beginning of the next period.

See [Figure 13-10](#) for an illustration of this sequence.

The Full-Bridge mode does not provide dead-band delay. As one output is modulated at a time, dead-band delay is generally not required. There is a situation where dead-band delay is required. This situation occurs when both of the following conditions are true:

1. The direction of the PWM output changes when the duty cycle of the output is at or near 100%.
2. The turn off time of the power switch, including the power device and driver circuit, is greater than the turn on time.

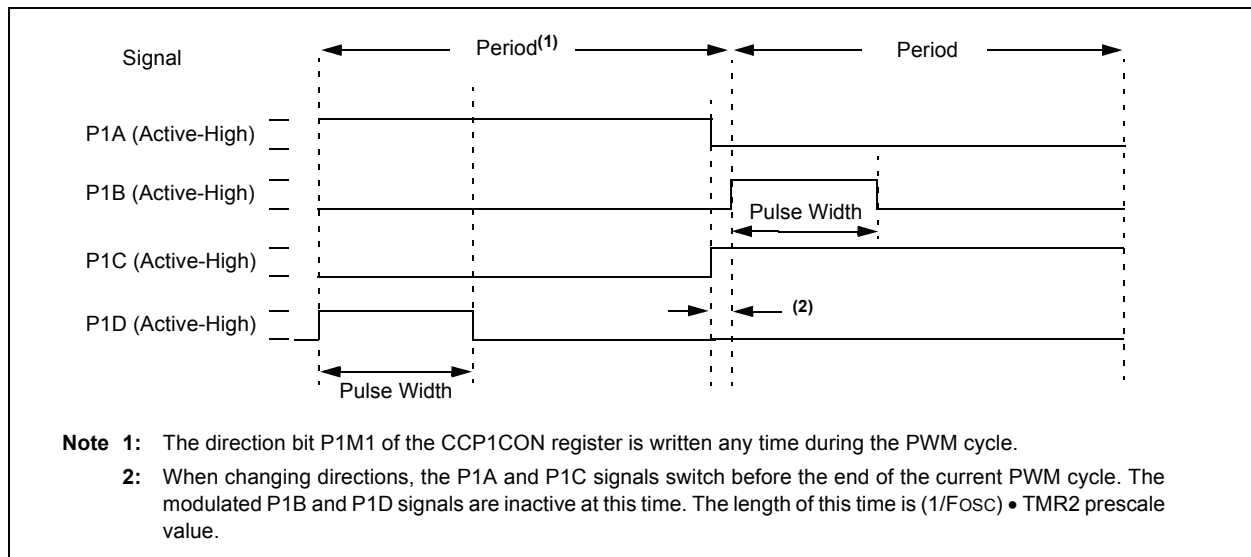
[Figure 13-11](#) shows an example of the PWM direction changing from forward to reverse, at a near 100% duty cycle. In this example, at time t1, the output P1A and P1D become inactive, while output P1C becomes active. Since the turn off time of the power devices is longer than the turn on time, a shoot-through current will flow through power devices QC and QD (see [Figure 13-8](#)) for the duration of 't'. The same phenomenon will occur to power devices QA and QB for PWM direction change from reverse to forward.

If changing PWM direction at high duty cycle is required for an application, two possible solutions for eliminating the shoot-through current are:

1. Reduce PWM duty cycle for one PWM period before changing directions.
2. Use switch drivers that can drive the switches off faster than they can drive them on.

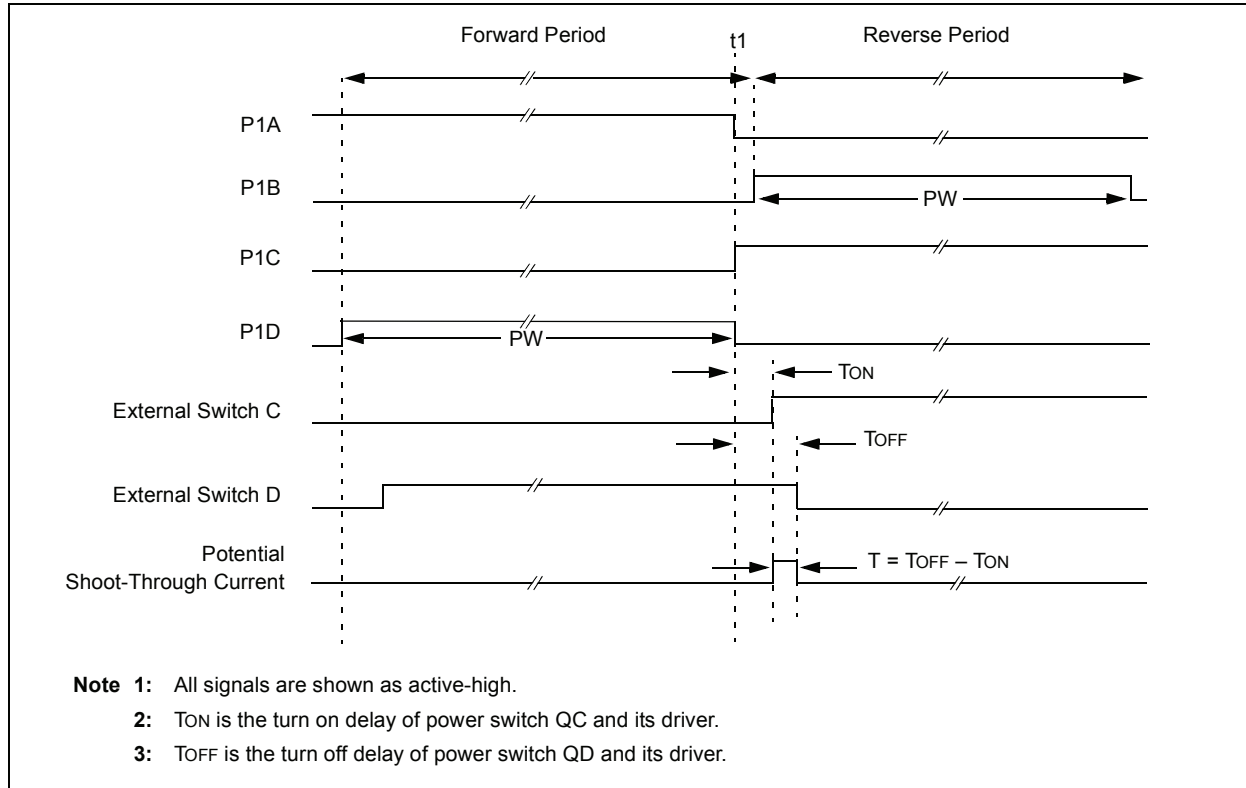
Other options to prevent shoot-through current may exist.

**FIGURE 13-10: EXAMPLE OF PWM DIRECTION CHANGE**



# PIC18(L)F1XK22

**FIGURE 13-11: EXAMPLE OF PWM DIRECTION CHANGE AT NEAR 100% DUTY CYCLE**



## 13.4.3 START-UP CONSIDERATIONS

When any PWM mode is used, the application hardware must use the proper external pull-up and/or pull-down resistors on the PWM output pins.

**Note:** When the microcontroller is released from Reset, all of the I/O pins are in the high-impedance state. The external circuits must keep the power switch devices in the Off state until the microcontroller drives the I/O pins with the proper signal levels or activates the PWM output(s).

The CCP1M<1:0> bits of the CCP1CON register allow the user to choose whether the PWM output signals are active-high or active-low for each pair of PWM output pins (P1A/P1C and P1B/P1D). The PWM output polarities must be selected before the PWM pin output drivers are enabled. Changing the polarity configuration while the PWM pin output drivers are enable is not recommended since it may result in damage to the application circuits.

The P1A, P1B, P1C and P1D output latches may not be in the proper states when the PWM module is initialized. Enabling the PWM pin output drivers at the same time as the Enhanced PWM modes may cause damage to the application circuit. The Enhanced PWM modes must be enabled in the proper Output mode and complete a full PWM cycle before enabling the PWM pin output drivers. The completion of a full PWM cycle is indicated by the TMR2IF bit of the PIR1 register being set as the second PWM period begins.

## 13.4.4 ENHANCED PWM AUTO-SHUTDOWN MODE

The PWM mode supports an Auto-Shutdown mode that will disable the PWM outputs when an external shutdown event occurs. Auto-Shutdown mode places the PWM output pins into a predetermined state. This mode is used to help prevent the PWM from damaging the application.

The auto-shutdown sources are selected using the ECCPAS<2:0> bits of the ECCPAS register. A shutdown event may be generated by:

- A logic '0' on the INT0 pin
- A logic '1' on a comparator (Cx) output

A shutdown condition is indicated by the ECCPASE (Auto-Shutdown Event Status) bit of the ECCPAS register. If the bit is a '0', the PWM pins are operating normally. If the bit is a '1', the PWM outputs are in the shutdown state.

When a shutdown event occurs, two things happen:

The ECCPASE bit is set to '1'. The ECCPASE will remain set until cleared in firmware or an auto-restart occurs (see [Section 13.4.5 "Auto-Restart Mode"](#)).

The enabled PWM pins are asynchronously placed in their shutdown states. The PWM output pins are grouped into pairs [P1A/P1C] and [P1B/P1D]. The state of each pin pair is determined by the PSSAC and PSSBD bits of the ECCPAS register. Each pin pair may be placed into one of three states:

- Drive logic '1'
- Drive logic '0'
- Tri-state (high-impedance)

### REGISTER 13-2: ECCP1AS: ENHANCED CAPTURE/COMPARE/PWM AUTO-SHUTDOWN CONTROL REGISTER

R/W-0	R/W-0	R/W-0	R/W-0	R/W-0	R/W-0	R/W-0	R/W-0
ECCPASE	ECCPAS2	ECCPAS1	ECCPAS0	PSSAC1	PSSAC0	PSSBD1	PSSBD0
bit 7							bit 0

#### Legend:

R = Readable bit	W = Writable bit	U = Unimplemented bit, read as '0'
-n = Value at POR	'1' = Bit is set	'0' = Bit is cleared
		x = Bit is unknown

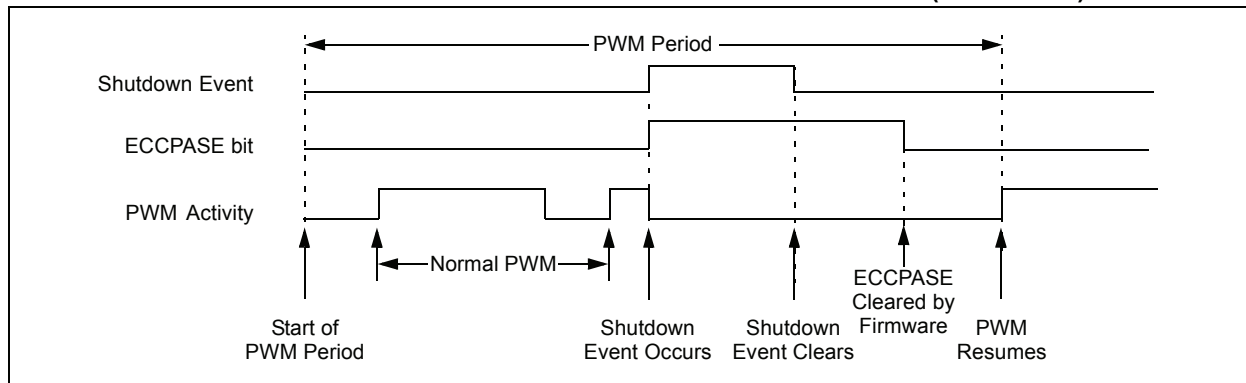
bit 7	<b>ECCPASE:</b> ECCP Auto-Shutdown Event Status bit 1 = A shutdown event has occurred; ECCP outputs are in shutdown state 0 = ECCP outputs are operating
bit 6-4	<b>ECCPAS&lt;2:0&gt;:</b> ECCP Auto-shutdown Source Select bits 000 = Auto-Shutdown is disabled 001 = Comparator C1OUT output is high 010 = Comparator C2OUT output is high 011 = Either Comparator C1OUT or C2OUT is high 100 = VIL on INT0 pin 101 = VIL on INT0 pin or Comparator C1OUT output is high 110 = VIL on INT0 pin or Comparator C2OUT output is high 111 = VIL on INT0 pin or Comparator C1OUT or Comparator C2OUT is high
bit 3-2	<b>PSSACn:</b> Pins P1A and P1C Shutdown State Control bits 00 = Drive pins P1A and P1C to '0' 01 = Drive pins P1A and P1C to '1' 1x = Pins P1A and P1C tri-state
bit 1-0	<b>PSSBDn:</b> Pins P1B and P1D Shutdown State Control bits 00 = Drive pins P1B and P1D to '0' 01 = Drive pins P1B and P1D to '1' 1x = Pins P1B and P1D tri-state

# PIC18(L)F1XK22

**Note 1:** The auto-shutdown condition is a level-based signal, not an edge-based signal. As long as the level is present, the auto-shutdown will persist.

- 2:** Writing to the ECCPASE bit is disabled while an auto-shutdown condition persists.
- 3:** Once the auto-shutdown condition has been removed and the PWM restarted (either through firmware or auto-restart) the PWM signal will always restart at the beginning of the next PWM period.
- 4:** Prior to an auto-shutdown event caused by a comparator output or INT pin event, a software shutdown can be triggered in firmware by setting the CCPxASE bit to a '1'. The Auto-Restart feature tracks the active status of a shutdown caused by a comparator output or INT pin event only, so if it is enabled at this time, it will immediately clear this bit and restart the ECCP module at the beginning of the next PWM period.

**FIGURE 13-12: PWM AUTO-SHUTDOWN WITH FIRMWARE RESTART (PRSEN = 0)**

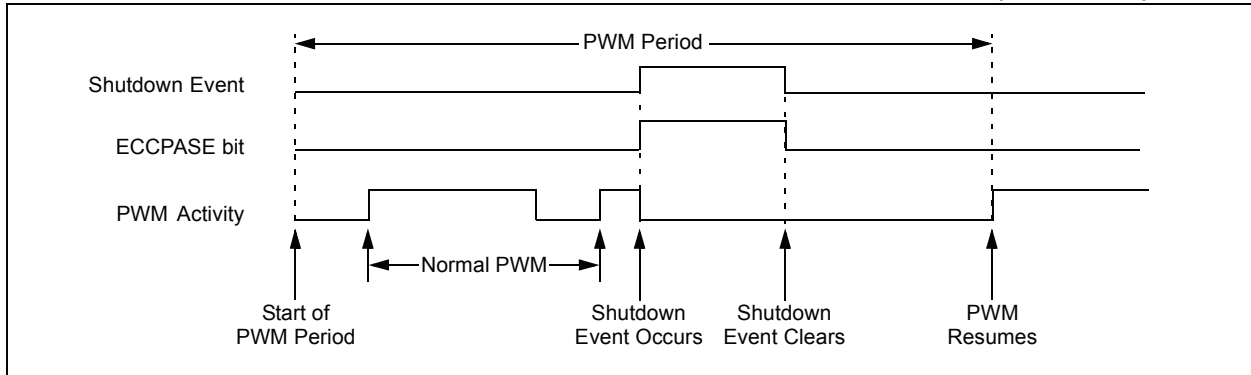


## 13.4.5 AUTO-RESTART MODE

The Enhanced PWM can be configured to automatically restart the PWM signal once the auto-shutdown condition has been removed. Auto-restart is enabled by setting the PRSEN bit in the PWM1CON register.

If auto-restart is enabled, the ECCPASE bit will remain set as long as the auto-shutdown condition is active. When the auto-shutdown condition is removed, the ECCPASE bit will be cleared via hardware and normal operation will resume.

**FIGURE 13-13: PWM AUTO-SHUTDOWN WITH AUTO-RESTART ENABLED (PRSEN = 1)**



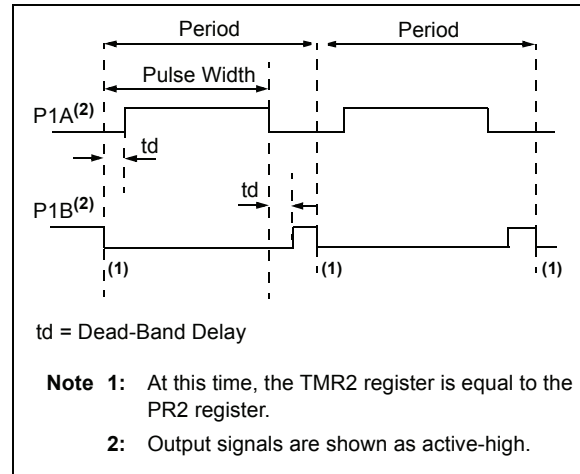
# PIC18(L)F1XK22

## 13.4.6 PROGRAMMABLE DEAD-BAND DELAY MODE

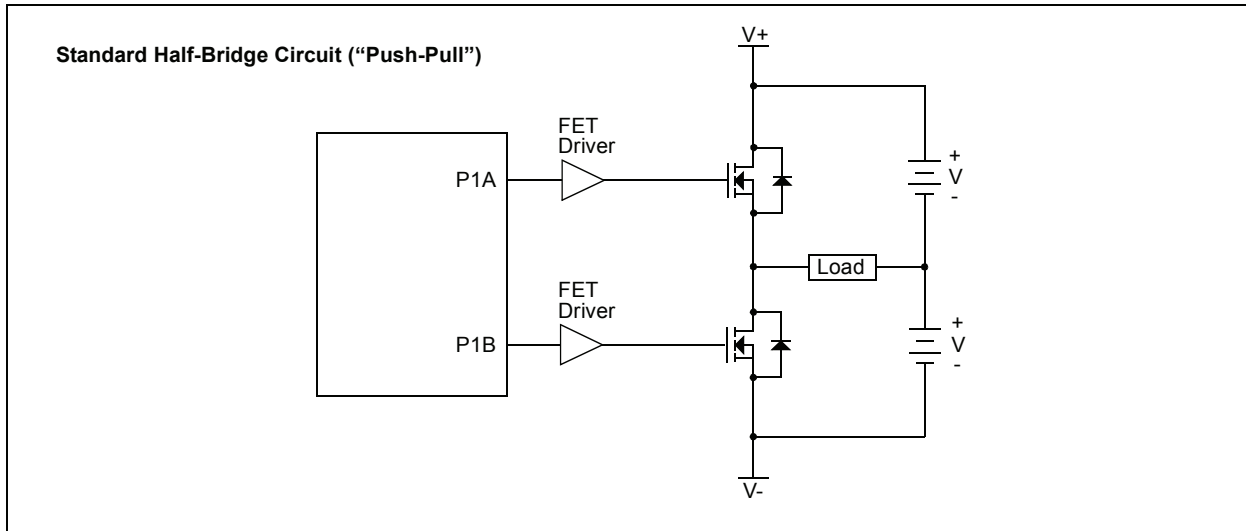
In Half-Bridge applications where all power switches are modulated at the PWM frequency, the power switches normally require more time to turn off than to turn on. If both the upper and lower power switches are switched at the same time (one turned on, and the other turned off), both switches may be on for a short period of time until one switch completely turns off. During this brief interval, a very high current (shoot-through current) will flow through both power switches, shorting the bridge supply. To avoid this potentially destructive shoot-through current from flowing during switching, turning on either of the power switches is normally delayed to allow the other switch to completely turn off.

In Half-Bridge mode, a digitally programmable dead-band delay is available to avoid shoot-through current from destroying the bridge power switches. The delay occurs at the signal transition from the non-active state to the active state. See Figure 13-14 for illustration. The lower seven bits of the associated PWM1CON register (Register 13-3) sets the delay period in terms of microcontroller instruction cycles ( $T_{CY}$  or  $4 T_{OSC}$ ).

**FIGURE 13-14: EXAMPLE OF HALF-BRIDGE PWM OUTPUT**



**FIGURE 13-15: EXAMPLE OF HALF-BRIDGE APPLICATIONS**



## REGISTER 13-3: PWM1CON: ENHANCED PWM CONTROL REGISTER

R/W-0	R/W-0	R/W-0	R/W-0	R/W-0	R/W-0	R/W-0	R/W-0
PRSEN	PDC6	PDC5	PDC4	PDC3	PDC2	PDC1	PDC0
bit 7							bit 0

### Legend:

R = Readable bit

W = Writable bit

U = Unimplemented bit, read as '0'

-n = Value at POR

'1' = Bit is set

'0' = Bit is cleared

x = Bit is unknown

bit 7

**PRSEN:** PWM Restart Enable bit

1 = Upon auto-shutdown, the ECCPASE bit clears automatically once the shutdown event goes away; the PWM restarts automatically

0 = Upon auto-shutdown, ECCPASE must be cleared by software to restart the PWM

bit 6-0

**PDC<6:0>:** PWM Delay Count bits

PDCn = Number of  $F_{osc}/4$  ( $4 * T_{osc}$ ) cycles between the scheduled time when a PWM signal **should** transition active and the **actual** time it transitions active

# PIC18(L)F1XK22

## 13.4.7 PULSE STEERING MODE

In Single Output mode, pulse steering allows any of the PWM pins to be the modulated signal. Additionally, the same PWM signal can be simultaneously available on multiple pins.

Once the Single Output mode is selected (CCP1M<3:2> = 11 and P1M<1:0> = 00 of the CCP1CON register), the user firmware can bring out the same PWM signal to one, two, three or four output pins by setting the appropriate STR<D:A> bits of the PSTRCON register, as shown in [Table 13-2](#).

**Note:** The associated TRIS bits must be set to output ('0') to enable the pin output driver in order to see the PWM signal on the pin.

While the PWM Steering mode is active, CCP1M<1:0> bits of the CCP1CON register select the PWM output polarity for the P1<D:A> pins.

The PWM auto-shutdown operation also applies to PWM Steering mode as described in [Section 13.4.4 “Enhanced PWM Auto-shutdown mode”](#). An auto-shutdown event will only affect pins that have PWM outputs enabled.

### REGISTER 13-4: PSTRCON: PULSE STEERING CONTROL REGISTER<sup>(1)</sup>

U-0	U-0	U-0	R/W-0	R/W-0	R/W-0	R/W-0	R/W-1	
—	—	—	STRSYNC	STRD	STRC	STRB	STRA	
bit 7								bit 0

**Legend:**

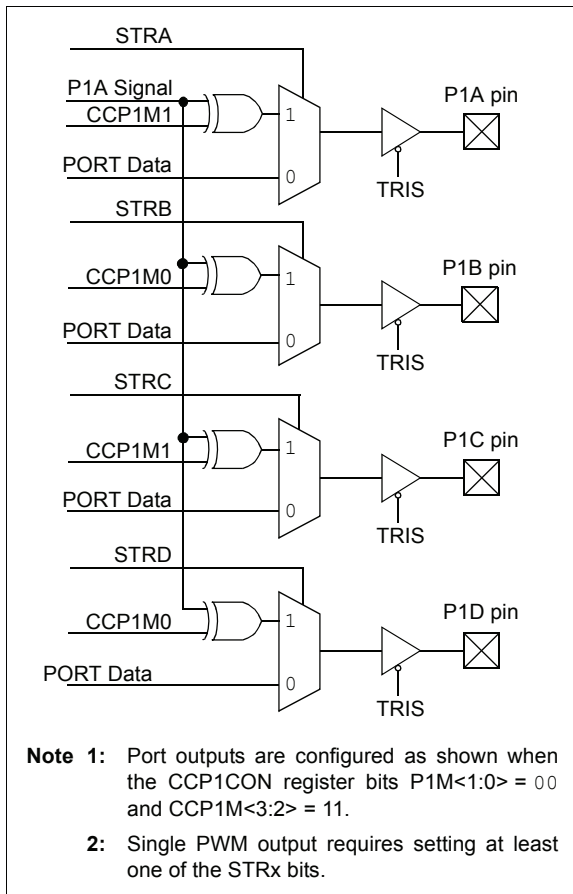
R = Readable bit	W = Writable bit	U = Unimplemented bit, read as '0'
-n = Value at POR	'1' = Bit is set	'0' = Bit is cleared      x = Bit is unknown

- bit 7-5      **Unimplemented:** Read as '0'
- bit 4      **STRSYNC:** Steering Sync bit
  - 1 = Output steering update occurs on next PWM period
  - 0 = Output steering update occurs at the beginning of the instruction cycle boundary
- bit 3      **STRD:** Steering Enable bit D
  - 1 = P1D pin has the PWM waveform with polarity control from CCP1M<1:0>
  - 0 = P1D pin is assigned to port pin
- bit 2      **STRC:** Steering Enable bit C
  - 1 = P1C pin has the PWM waveform with polarity control from CCP1M<1:0>
  - 0 = P1C pin is assigned to port pin
- bit 1      **STRB:** Steering Enable bit B
  - 1 = P1B pin has the PWM waveform with polarity control from CCP1M<1:0>
  - 0 = P1B pin is assigned to port pin
- bit 0      **STRA:** Steering Enable bit A
  - 1 = P1A pin has the PWM waveform with polarity control from CCP1M<1:0>
  - 0 = P1A pin is assigned to port pin

**Note 1:** The PWM Steering mode is available only when the CCP1CON register bits CCP1M<3:2> = 11 and P1M<1:0> = 00.



**FIGURE 13-16: SIMPLIFIED STEERING BLOCK DIAGRAM**



# PIC18(L)F1XK22

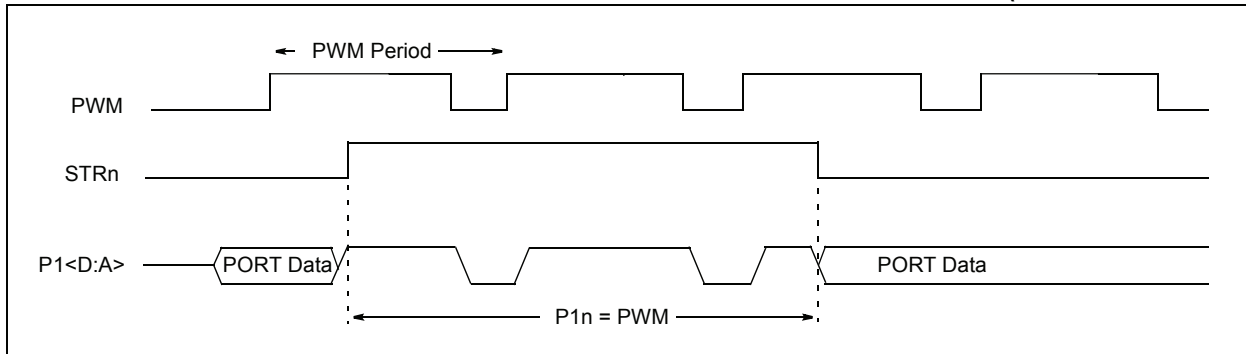
## 13.4.7.1 Steering Synchronization

The STRSYNC bit of the PSTRCON register gives the user two selections of when the steering event will happen. When the STRSYNC bit is '0', the steering event will happen at the end of the instruction that writes to the PSTRCON register. In this case, the output signal at the P1<D:A> pins may be an incomplete PWM waveform. This operation is useful when the user firmware needs to immediately remove a PWM signal from the pin.

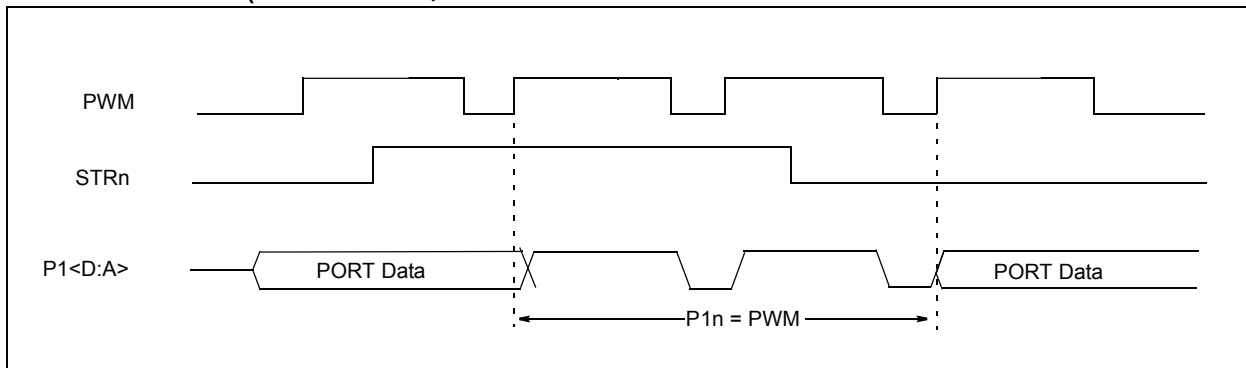
When the STRSYNC bit is '1', the effective steering update will happen at the beginning of the next PWM period. In this case, steering on/off the PWM output will always produce a complete PWM waveform.

Figures 13-17 and 13-18 illustrate the timing diagrams of the PWM steering depending on the STRSYNC setting.

**FIGURE 13-17: EXAMPLE OF STEERING EVENT AT END OF INSTRUCTION (STRSYNC = 0)**



**FIGURE 13-18: EXAMPLE OF STEERING EVENT AT BEGINNING OF INSTRUCTION (STRSYNC = 1)**



## 13.4.8 OPERATION IN POWER-MANAGED MODES

In Sleep mode, all clock sources are disabled. Timer2 will not increment and the state of the module will not change. If the ECCP pin is driving a value, it will continue to drive that value. When the device wakes up, it will continue from this state. If Two-Speed Start-ups are enabled, the initial start-up frequency from HFINTOSC and the postscaler may not be stable immediately.

In PRI\_IDLE mode, the primary clock will continue to clock the ECCP module without change. In all other power-managed modes, the selected power-managed mode clock will clock Timer2. Other power-managed mode clocks will most likely be different than the primary clock frequency.

## 13.4.8.1 Operation with Fail-Safe Clock Monitor

If the Fail-Safe Clock Monitor is enabled, a clock failure will force the device into the RC\_RUN Power-Managed mode and the OSCFIF bit of the PIR2 register will be set. The ECCP will then be clocked from the internal oscillator clock source, which may have a different clock frequency than the primary clock.

See the previous section for additional details.

## 13.4.9 EFFECTS OF A RESET

Both Power-on Reset and subsequent Resets will force all ports to Input mode and the CCP registers to their Reset states.

This forces the enhanced CCP module to reset to a state compatible with the standard CCP module.

**TABLE 13-3: REGISTERS ASSOCIATED WITH ECCP1 MODULE AND TIMER1 TO TIMER3**

Name	Bit 7	Bit 6	Bit 5	Bit 4	Bit 3	Bit 2	Bit 1	Bit 0	Reset Values on page
CCPR1H	Capture/Compare/PWM Register 1, High Byte								255
CCPR1L	Capture/Compare/PWM Register 1, Low Byte								255
CCP1CON	P1M1	P1M0	DC1B1	DC1B0	CCP1M3	CCP1M2	CCP1M1	CCP1M0	255
ECCP1AS	ECCPASE	ECCPAS2	ECCPAS1	ECCPAS0	PSSAC1	PSSAC0	PSSBD1	PSSBD0	255
INTCON	GIE/GIEH	PEIE/GIEL	TMR0IE	INT0IE	RABIE	TMR0IF	INT0IF	RABIF	253
IPR1	—	ADIP	RCIP	TXIP	SSPIP	CCP1IP	TMR2IP	TMR1IP	256
IPR2	OSCFIF	C1IP	C2IP	EEIP	BCLIP	—	TMR3IP	—	256
PIE1	—	ADIE	RCIE	TXIE	SSPIE	CCP1IE	TMR2IE	TMR1IE	256
PIE2	OSCFIE	C1IE	C2IE	EEIE	BCLIE	—	TMR3IE	—	256
PIR1	—	ADIF	RCIF	TXIF	SSPIF	CCP1IF	TMR2IF	TMR1IF	256
PIR2	OSCFIF	C1IF	C2IF	EEIF	BCLIF	—	TMR3IF	—	256
PR2	Timer2 Period Register								254
PWM1CON	PRSEN	PDC6	PDC5	PDC4	PDC3	PDC2	PDC1	PDC0	255
RCON	IPEN	SBOREN	—	$\overline{RI}$	$\overline{TO}$	$\overline{PD}$	$\overline{POR}$	$\overline{BOR}$	254
TMR1H	Timer1 Register, High Byte								254
TMR1L	Timer1 Register, Low Byte								254
TMR2	Timer2 Register								254
TMR3H	Timer3 Register, High Byte								255
TMR3L	Timer3 Register, Low Byte								255
TRISC	TRISC7	TRISC6	TRISC5	TRISC4	TRISC3	TRISC2	TRISC1	TRISC0	256
T1CON	RD16	T1RUN	T1CKPS1	T1CKPS0	T1OSCEN	$\overline{T1SYNC}$	TMR1CS	TMR1ON	254
T2CON	—	T2OUTPS3	T2OUTPS2	T2OUTPS1	T2OUTPS0	TMR2ON	T2CKPS1	T2CKPS0	254
T3CON	RD16	—	T3CKPS1	T3CKPS0	T3CCP1	$\overline{T3SYNC}$	TMR3CS	TMR3ON	255

**Legend:** — = unimplemented, read as '0'. Shaded cells are not used during ECCP operation.

# PIC18(L)F1XK22

---

NOTES:

## 14.0 MASTER SYNCHRONOUS SERIAL PORT (MSSP) MODULE

### 14.1 Master SSP (MSSP) Module Overview

The Master Synchronous Serial Port (MSSP) module is a serial interface, useful for communicating with other peripheral or microcontroller devices. These peripheral devices may be serial EEPROMs, shift registers, display drivers, A/D converters, etc. The MSSP module can operate in one of two modes:

- Serial Peripheral Interface (SPI)
- Inter-Integrated Circuit (I<sup>2</sup>C™)
  - Full Master mode
  - Slave mode (with general address call)

The I<sup>2</sup>C interface supports the following modes in hardware:

- Master mode
- Multi-Master mode
- Slave mode

### 14.2 SPI Mode

The SPI mode allows 8 bits of data to be synchronously transmitted and received simultaneously. All four modes of SPI are supported. To accomplish communication, typically three pins are used:

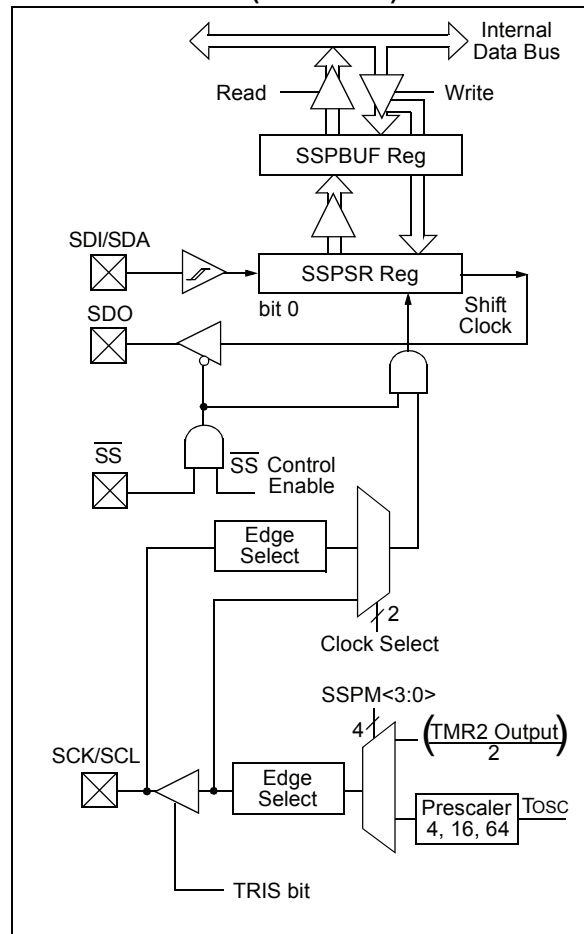
- Serial Data Out – SDO
- Serial Data In – SDI
- Serial Clock – SCK

Additionally, a fourth pin may be used when in a Slave mode of operation:

- Slave Select –  $\overline{SS}$

Figure 14-1 shows the block diagram of the MSSP module when operating in SPI mode.

**FIGURE 14-1: MSSP BLOCK DIAGRAM (SPI MODE)**



# PIC18(L)F1XK22

## 14.2.1 REGISTERS

The MSSP module has four registers for SPI mode operation. These are:

- SSPCON1 – Control Register
- SSPSTAT – STATUS register
- SSPBUF – Serial Receive/Transmit Buffer
- SSPSR – Shift Register (Not directly accessible)

SSPCON1 and SSPSTAT are the control and STATUS registers in SPI mode operation. The SSPCON1 register is readable and writable. The lower 6 bits of the SSPSTAT are read-only. The upper two bits of the SSPSTAT are read/write.

SSPSR is the shift register used for shifting data in and out. SSPBUF provides indirect access to the SSPSR register. SSPBUF is the buffer register to which data bytes are written, and from which data bytes are read.

In receive operations, SSPSR and SSPBUF together create a double-buffered receiver. When SSPSR receives a complete byte, it is transferred to SSPBUF and the SSPIF interrupt is set.

During transmission, the SSPBUF is not double-buffered. A write to SSPBUF will write to both SSPBUF and SSPSR.

### REGISTER 14-1: SSPSTAT: MSSP STATUS REGISTER (SPI MODE)

R/W-0	R/W-0	R-0	R-0	R-0	R-0	R-0	R-0
SMP	CKE	D/A	P	S	R/W	UA	BF
bit 7							bit 0

#### Legend:

R = Readable bit

W = Writable bit

U = Unimplemented bit, read as '0'

-n = Value at POR

'1' = Bit is set

'0' = Bit is cleared

x = Bit is unknown

bit 7

**SMP:** Sample bit

SPI Master mode:

1 = Input data sampled at end of data output time

0 = Input data sampled at middle of data output time

SPI Slave mode:

SMP must be cleared when SPI is used in Slave mode.

bit 6

**CKE:** SPI Clock Select bit<sup>(1)</sup>

1 = Transmit occurs on transition from active to Idle clock state

0 = Transmit occurs on transition from Idle to active clock state

bit 5

**D/A:** Data/Address bit

Used in I<sup>2</sup>C mode only.

bit 4

**P:** Stop bit

Used in I<sup>2</sup>C mode only. This bit is cleared when the MSSP module is disabled, SSPEN is cleared.

bit 3

**S:** Start bit

Used in I<sup>2</sup>C mode only.

bit 2

**R/W:** Read/Write Information bit

Used in I<sup>2</sup>C mode only.

bit 1

**UA:** Update Address bit

Used in I<sup>2</sup>C mode only.

bit 0

**BF:** Buffer Full Status bit (Receive mode only)

1 = Receive complete, SSPBUF is full

0 = Receive not complete, SSPBUF is empty

**Note 1:** Polarity of clock state is set by the CKP bit of the SSPCON1 register.

## REGISTER 14-2: SSPCON1: MSSP CONTROL 1 REGISTER (SPI MODE)

R/W-0	R/W-0	R/W-0	R/W-0	R/W-0	R/W-0	R/W-0	R/W-0
WCOL	SSPOV	SSPEN	CKP	SSPM3	SSPM2	SSPM1	SSPM0
bit 7							bit 0

### Legend:

R = Readable bit

W = Writable bit

U = Unimplemented bit, read as '0'

-n = Value at POR

'1' = Bit is set

'0' = Bit is cleared

x = Bit is unknown

- bit 7      **WCOL:** Write Collision Detect bit (Transmit mode only)  
 1 = The SSPBUF register is written while it is still transmitting the previous word (must be cleared by software)  
 0 = No collision
- bit 6      **SSPOV:** Receive Overflow Indicator bit<sup>(1)</sup>  
SPI Slave mode:  
 1 = A new byte is received while the SSPBUF register is still holding the previous data. In case of overflow, the data in SSPSR is lost. Overflow can only occur in Slave mode. The user must read the SSPBUF, even if only transmitting data, to avoid setting overflow (must be cleared by software).  
 0 = No overflow
- bit 5      **SSPEN:** Synchronous Serial Port Enable bit<sup>(2)</sup>  
 1 = Enables serial port and configures SCK, SDO, SDI and  $\overline{SS}$  as serial port pins  
 0 = Disables serial port and configures these pins as I/O port pins
- bit 4      **CKP:** Clock Polarity Select bit  
 1 = Idle state for clock is a high level  
 0 = Idle state for clock is a low level
- bit 3-0    **SSPM<3:0>:** Synchronous Serial Port Mode Select bits<sup>(3)</sup>  
 0101 = SPI Slave mode, clock = SCK pin,  $\overline{SS}$  pin control disabled,  $\overline{SS}$  can be used as I/O pin  
 0100 = SPI Slave mode, clock = SCK pin,  $\overline{SS}$  pin control enabled  
 0011 = SPI Master mode, clock = TMR2 output/2  
 0010 = SPI Master mode, clock = FOSC/64  
 0001 = SPI Master mode, clock = FOSC/16  
 0000 = SPI Master mode, clock = FOSC/4

**Note 1:** In Master mode, the overflow bit is not set since each new reception (and transmission) is initiated by writing to the SSPBUF register.

**2:** When enabled, these pins must be properly configured as input or output.

**3:** Bit combinations not specifically listed here are either reserved or implemented in I<sup>2</sup>C mode only.

# PIC18(L)F1XK22

## 14.2.2 OPERATION

When initializing the SPI, several options need to be specified. This is done by programming the appropriate control bits (SSPCON1<5:0> and SSPSTAT<7:6>). These control bits allow the following to be specified:

- Master mode (SCK is the clock output)
- Slave mode (SCK is the clock input)
- Clock Polarity (Idle state of SCK)
- Data Input Sample Phase (middle or end of data output time)
- Clock Edge (output data on rising/falling edge of SCK)
- Clock Rate (Master mode only)
- Slave Select mode (Slave mode only)

The MSSP consists of a transmit/receive shift register (SSPSR) and a buffer register (SSPBUF). The SSPSR shifts the data in and out of the device, MSb first. The SSPBUF holds the data that was written to the SSPSR until the received data is ready. Once the 8 bits of data have been received, that byte is moved to the SSPBUF register. Then, the Buffer Full detect bit, BF of the SSPSTAT register, and the interrupt flag bit, SSPIF, are set. This double-buffering of the received data (SSPBUF) allows the next byte to start reception before reading the data that was just received. Any write to the SSPBUF register during transmission/reception of data will be ignored and the write collision detect bit WCOL of the SSPCON1 register, will be set. User software must clear the WCOL bit to allow the following write(s) to the SSPBUF register to complete successfully.

When the application software is expecting to receive valid data, the SSPBUF should be read before the next byte of data to transfer is written to the SSPBUF. The Buffer Full bit, BF of the SSPSTAT register, indicates when SSPBUF has been loaded with the received data (transmission is complete). When the SSPBUF is read, the BF bit is cleared. This data may be irrelevant if the SPI is only a transmitter. Generally, the MSSP interrupt is used to determine when the transmission/reception has completed. If the interrupt method is not going to be used, then software polling can be done to ensure that a write collision does not occur. [Example 14-1](#) shows the loading of the SSPBUF (SSPSR) for data transmission.

The SSPSR is not directly readable or writable and can only be accessed by addressing the SSPBUF register. Additionally, the MSSP STATUS register (SSPSTAT) indicates the various status conditions.

### EXAMPLE 14-1: LOADING THE SSPBUF (SSPSR) REGISTER

LOOP	BTFSS	SSPSTAT, BF	;Has data been received (transmit complete)?
	BRA	LOOP	;No
	MOVF	SSPBUF, W	;WREG reg = contents of SSPBUF
	MOVWF	RXDATA	;Save in user RAM, if data is meaningful
	MOVF	TXDATA, W	;W reg = contents of TXDATA
	MOVWF	SSPBUF	;New data to xmit



## 14.2.3 ENABLING SPI I/O

To enable the serial port, SSP Enable bit, SSPEN of the SSPCON1 register, must be set. To reset or reconfigure SPI mode, clear the SSPEN bit, reinitialize the SSPCON registers and then set the SSPEN bit. This configures the SDI, SDO, SCK and  $\overline{SS}$  pins as serial port pins. For the pins to behave as the serial port function, some must have their data direction bits (in the TRIS register) appropriately programmed as follows:

- SDI is automatically controlled by the SPI module
- SDO must have corresponding TRIS bit cleared
- SCK (Master mode) must have corresponding TRIS bit cleared
- SCK (Slave mode) must have corresponding TRIS bit set
- $\overline{SS}$  must have corresponding TRIS bit set

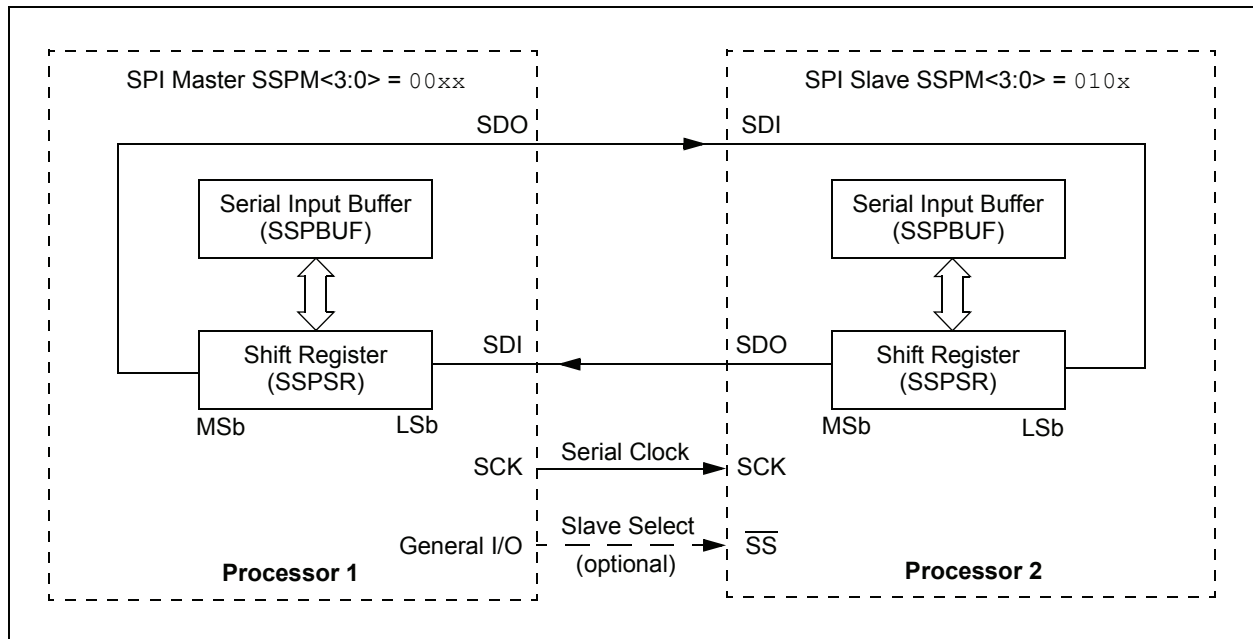
Any serial port function that is not desired may be overridden by programming the corresponding data direction (TRIS) register to the opposite value.

## 14.2.4 TYPICAL CONNECTION

Figure 14-2 shows a typical connection between two microcontrollers. The master controller (Processor 1) initiates the data transfer by sending the SCK signal. Data is shifted out of both shift registers on their programmed clock edge and latched on the opposite edge of the clock. Both processors should be programmed to the same Clock Polarity (CKP), then both controllers would send and receive data at the same time. Whether the data is meaningful (or dummy data) depends on the application software. This leads to three scenarios for data transmission:

- Master sends data – Slave sends dummy data
- Master sends data – Slave sends data
- Master sends dummy data – Slave sends data

**FIGURE 14-2: TYPICAL SPI MASTER/SLAVE CONNECTION**



# PIC18(L)F1XK22

## 14.2.5 MASTER MODE

The master can initiate the data transfer at any time because it controls the SCK. The master determines when the slave (Processor 2, Figure 14-2) is to broadcast data by the software protocol.

In Master mode, the data is transmitted/received as soon as the SSPBUF register is written to. If the SPI is only going to receive, the SDO output could be disabled (programmed as an input). The SSPSR register will continue to shift in the signal present on the SDI pin at the programmed clock rate. As each byte is received, it will be loaded into the SSPBUF register as if a normal received byte (interrupts and Status bits appropriately set).

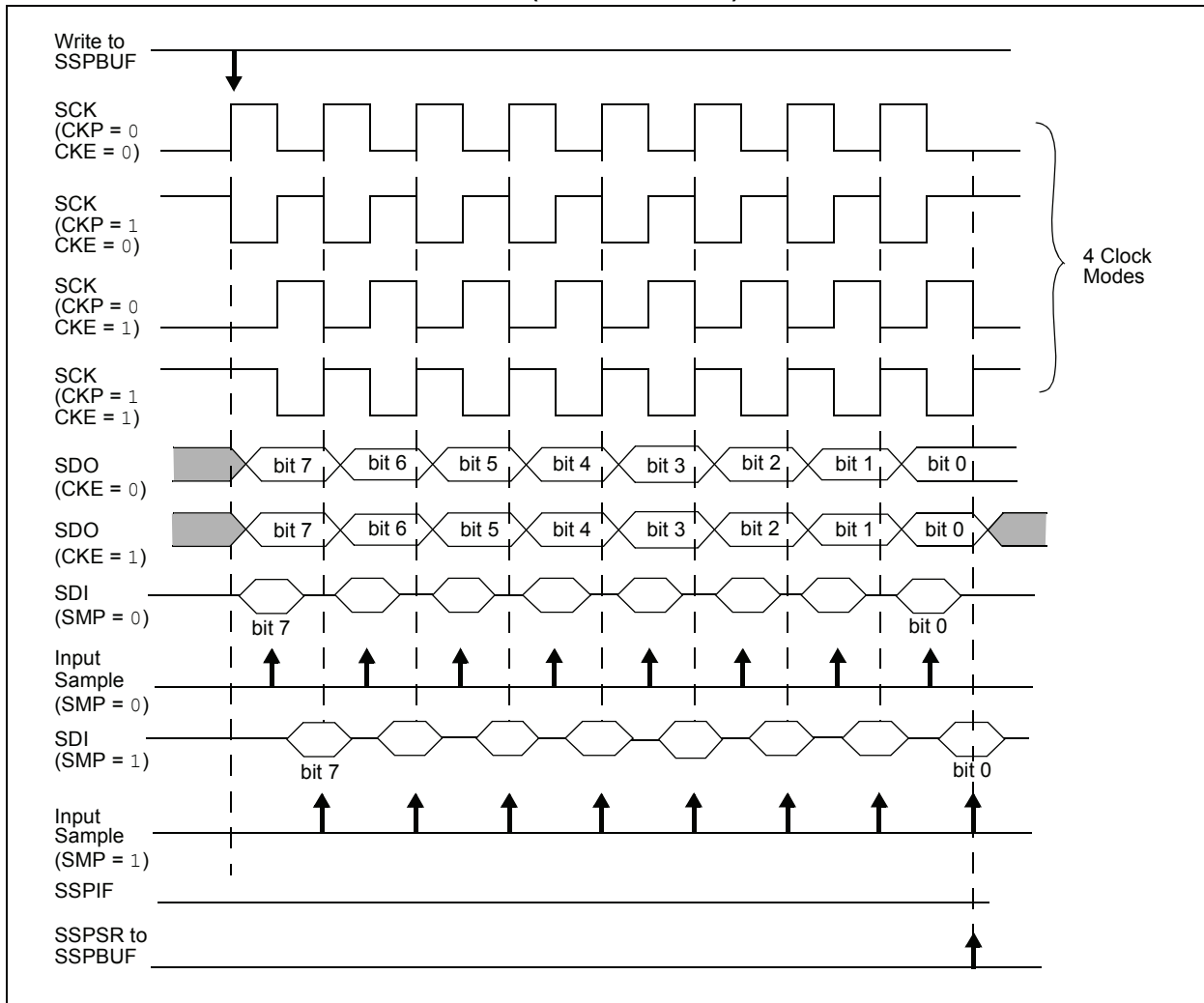
The clock polarity is selected by appropriately programming the CKP bit of the SSPCON1 register. This then, would give waveforms for SPI communication as shown in Figure 14-3, Figure 14-5 and Figure 14-6, where the MSB is transmitted first. In Master mode, the SPI clock rate (bit rate) is user programmable to be one of the following:

- $F_{osc}/4$  (or  $T_{CY}$ )
- $F_{osc}/16$  (or  $4 \cdot T_{CY}$ )
- $F_{osc}/64$  (or  $16 \cdot T_{CY}$ )
- $Timer2\ output/2$

This allows a maximum data rate (at 64 MHz) of 16.00 Mbps.

Figure 14-3 shows the waveforms for Master mode. When the CKE bit is set, the SDO data is valid before there is a clock edge on SCK. The change of the input sample is shown based on the state of the SMP bit. The time when the SSPBUF is loaded with the received data is shown.

**FIGURE 14-3: SPI MODE WAVEFORM (MASTER MODE)**



## 14.2.6 SLAVE MODE

In Slave mode, the data is transmitted and received as external clock pulses appear on SCK. When the last bit is latched, the SSPIF interrupt flag bit is set.

Before enabling the module in SPI Slave mode, the clock line must match the proper Idle state. The clock line can be observed by reading the SCK pin. The Idle state is determined by the CKP bit of the SSPCON1 register.

While in Slave mode, the external clock is supplied by the external clock source on the SCK pin. This external clock must meet the minimum high and low times as specified in the electrical specifications.

While in Sleep mode, the slave can transmit/receive data. When a byte is received, the device will wake-up from Sleep.

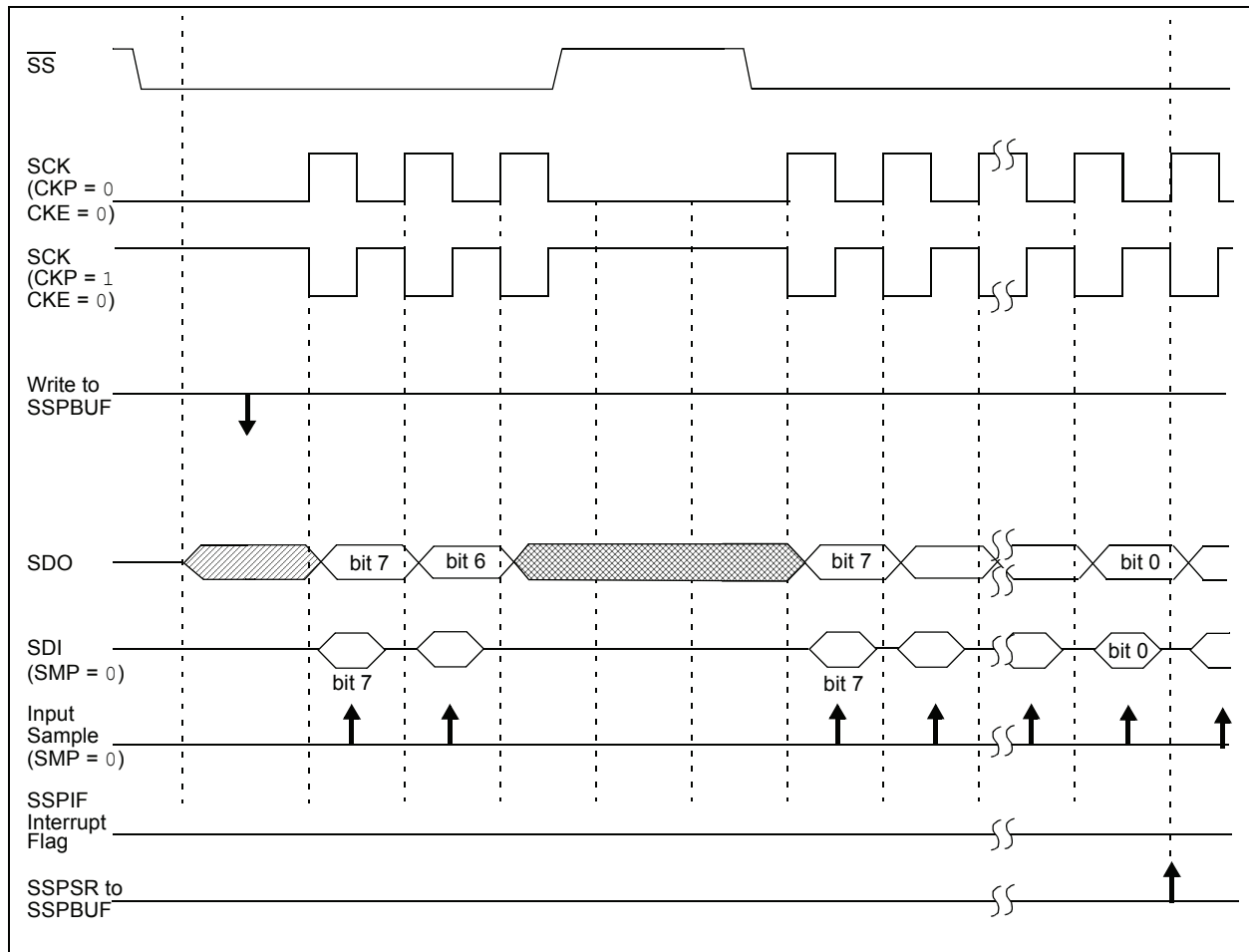
## 14.2.7 SLAVE SELECT SYNCHRONIZATION

The  $\overline{SS}$  pin allows a Synchronous Slave mode. The SPI must be in Slave mode with  $\overline{SS}$  pin control enabled ( $SSPCON1<3:0> = 0100$ ). When the  $\overline{SS}$  pin is low, transmission and reception are enabled and the SDO pin is driven. When the  $\overline{SS}$  pin goes high, the SDO pin is no longer driven, even if in the middle of a transmitted byte and becomes a floating output. External pull-up/pull-down resistors may be desirable depending on the application.

- Note 1:** When the SPI is in Slave mode with  $\overline{SS}$  pin control enabled ( $SSPCON<3:0> = 0100$ ), the SPI module will reset if the  $\overline{SS}$  pin is set to VDD.
- 2:** When the SPI is used in Slave mode with CKE set the  $\overline{SS}$  pin control must also be enabled.

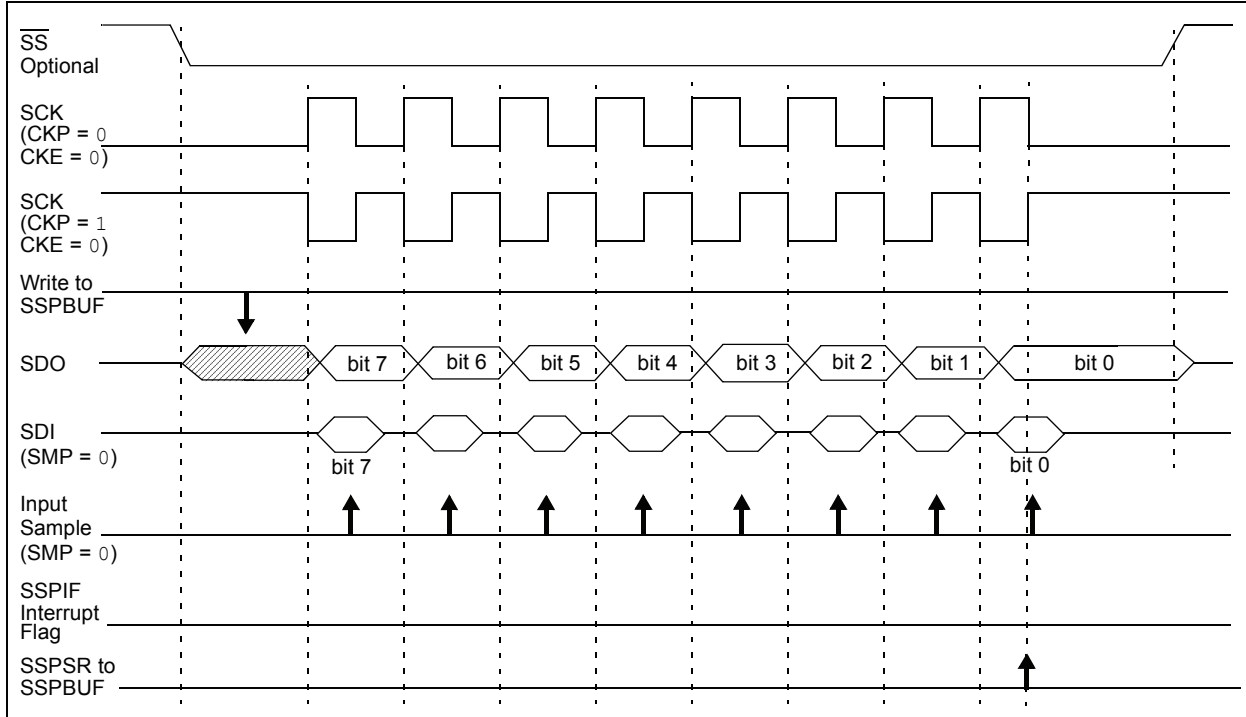
When the SPI module resets, the bit counter is forced to '0'. This can be done by either forcing the  $\overline{SS}$  pin to a high level or clearing the SSPEN bit.

**FIGURE 14-4: SLAVE SYNCHRONIZATION WAVEFORM**

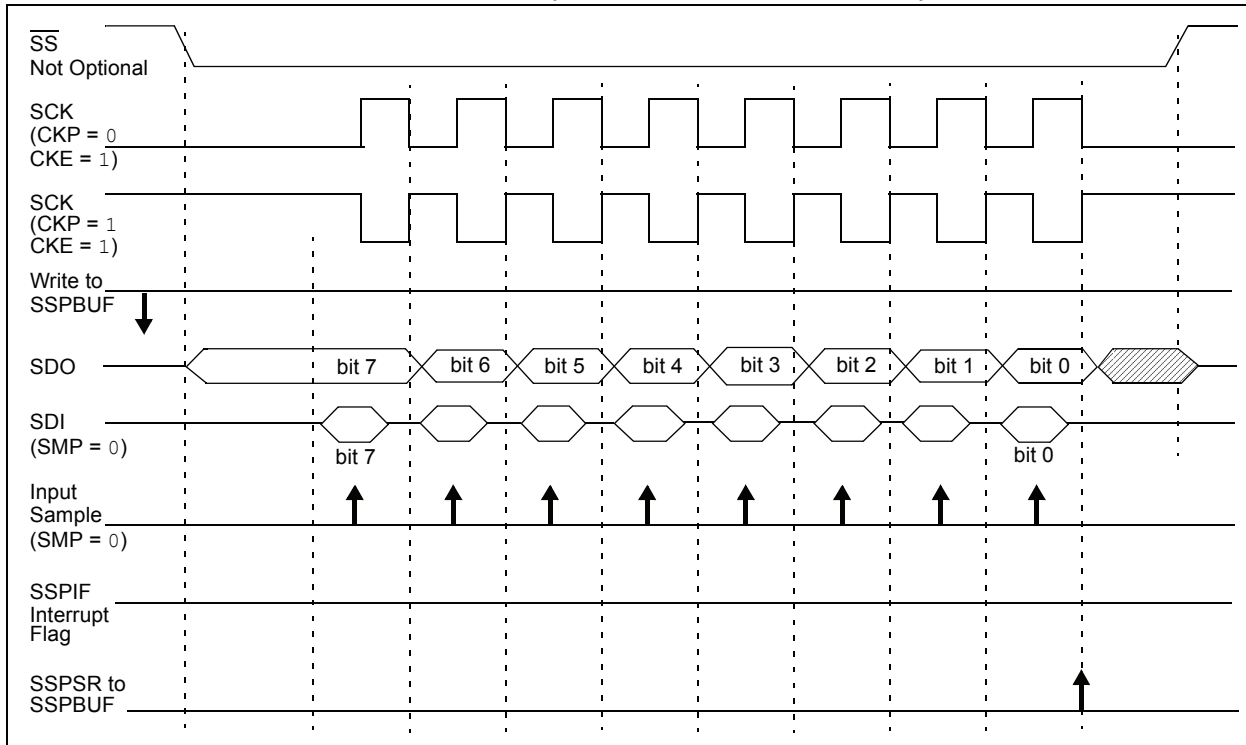


# PIC18(L)F1XK22

**FIGURE 14-5: SPI MODE WAVEFORM (SLAVE MODE WITH CKE = 0)**



**FIGURE 14-6: SPI MODE WAVEFORM (SLAVE MODE WITH CKE = 1)**



## 14.2.8 OPERATION IN POWER-MANAGED MODES

In SPI Master mode, module clocks may be operating at a different speed than when in Full Power mode; in the case of the Sleep mode, all clocks are halted.

In all Idle modes, a clock is provided to the peripherals. That clock could be from the primary clock source, the secondary clock (Timer1 oscillator at 32.768 kHz) or the INTOSC source. See [Section 18.0 “Power-Managed Modes”](#) for additional information.

In most cases, the speed that the master clocks SPI data is not important; however, this should be evaluated for each system.

When MSSP interrupts are enabled, after the master completes sending data, an MSSP interrupt will wake the controller:

- from Sleep, in Slave mode
- from Idle, in Slave or Master mode

If an exit from Sleep or Idle mode is not desired, MSSP interrupts should be disabled.

In SPI Master mode, when the Sleep mode is selected, all module clocks are halted and the transmission/reception will remain in that state until the device wakes. After the device returns to Run mode, the module will resume transmitting and receiving data.

In SPI Slave mode, the SPI Transmit/Receive Shift register operates asynchronously to the device. This allows the device to be placed in any Power-Managed mode and data to be shifted into the SPI

Transmit/Receive Shift register. When all 8 bits have been received, the MSSP interrupt flag bit will be set and if enabled, will wake the device.

## 14.2.9 EFFECTS OF A RESET

A Reset disables the MSSP module and terminates the current transfer.

## 14.2.10 BUS MODE COMPATIBILITY

[Table 14-1](#) shows the compatibility between the standard SPI modes and the states of the CKP and CKE control bits.

**TABLE 14-1: SPI BUS MODES**

Standard SPI Mode Terminology	Control Bits State	
	CKP	CKE
0, 0	0	1
0, 1	0	0
1, 0	1	1
1, 1	1	0

There is also an SMP bit which controls when the data is sampled.

**TABLE 14-2: REGISTERS ASSOCIATED WITH SPI OPERATION**

Name	Bit 7	Bit 6	Bit 5	Bit 4	Bit 3	Bit 2	Bit 1	Bit 0	Reset Values on page
INTCON	GIE/GIEH	PEIE/GIEL	TMR0IE	INT0IE	RABIE	TMR0IF	INT0IF	RABIF	253
IPR1	—	ADIP	RCIP	TXIP	SSPIP	CCP1IP	TMR2IP	TMR1IP	256
PIE1	—	ADIE	RCIE	TXIE	SSPIE	CCP1IE	TMR2IE	TMR1IE	256
PIR1	—	ADIF	RCIF	TXIF	SSPIF	CCP1IF	TMR2IF	TMR1IF	256
TRISB	TRISB7	TRISB6	TRISB5	TRISB4	—	—	—	—	256
TRISC	TRISC7	TRISC6	TRISC5	TRISC4	TRISC3	TRISC2	TRISC1	TRISC0	256
SSPBUF	SSP Receive Buffer/Transmit Register								254
SSPCON1	WCOL	SSPOV	SSPEN	CKP	SSPM3	SSPM2	SSPM1	SSPM0	254
SSPSTAT	SMP	CKE	D/Ā	P	S	R/W	UA	BF	254

**Legend:** Shaded cells are not used by the MSSP in SPI mode.

# PIC18(L)F1XK22

## 14.3 I<sup>2</sup>C Mode

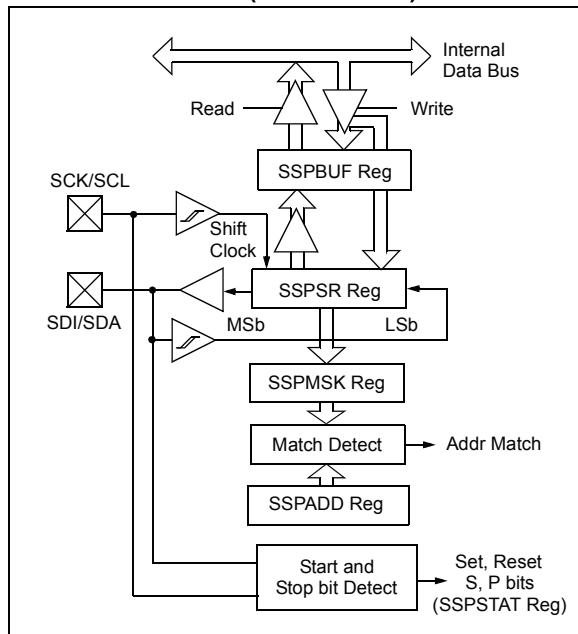
The MSSP module in I<sup>2</sup>C mode fully implements all master and slave functions (including general call support) and provides interrupts on Start and Stop bits in hardware to determine a free bus (multi-master function). The MSSP module implements the standard mode specifications as well as 7-bit and 10-bit addressing.

Two pins are used for data transfer:

- Serial clock – SCL
- Serial data – SDA

**Note:** The user must configure these pins as inputs with the corresponding TRIS bits.

**FIGURE 14-7: MSSP BLOCK DIAGRAM (I<sup>2</sup>C™ MODE)**



### 14.3.1 REGISTERS

The MSSP module has seven registers for I<sup>2</sup>C operation. These are:

- MSSP Control Register 1 (SSPCON1)
- MSSP Control Register 2 (SSPCON2)
- MSSP Status register (SSPSTAT)
- Serial Receive/Transmit Buffer Register (SSPBUF)
- MSSP Shift Register (SSPSR) – Not directly accessible
- MSSP Address Register (SSPADD)
- MSSP Address Mask (SSPMASK)

SSPCON1, SSPCON2 and SSPSTAT are the control and STATUS registers in I<sup>2</sup>C mode operation. The SSPCON1 and SSPCON2 registers are readable and writable. The lower 6 bits of the SSPSTAT are read-only. The upper two bits of the SSPSTAT are read/write.

SSPSR is the shift register used for shifting data in or out. SSPBUF is the buffer register to which data bytes are written to or read from.

When the MSSP is configured in Master mode, the SSPADD register acts as the Baud Rate Generator reload value. When the MSSP is configured for I<sup>2</sup>C Slave mode the SSPADD register holds the slave device address. The MSSP can be configured to respond to a range of addresses by qualifying selected bits of the address register with the SSPMSK register.

In receive operations, SSPSR and SSPBUF together create a double-buffered receiver. When SSPSR receives a complete byte, it is transferred to SSPBUF and the SSPIF interrupt is set.

During transmission, the SSPBUF is not double-buffered. A write to SSPBUF will write to both SSPBUF and SSPSR.

## REGISTER 14-3: SSPSTAT: MSSP STATUS REGISTER (I<sup>2</sup>C MODE)

R/W-0	R/W-0	R-0	R-0	R-0	R-0	R-0	R-0
SMP	CKE	D/A	P <sup>(1)</sup>	S <sup>(1)</sup>	R/W <sup>(2, 3)</sup>	UA	BF
bit 7							bit 0

### Legend:

R = Readable bit	W = Writable bit	U = Unimplemented bit, read as '0'
-n = Value at POR	'1' = Bit is set	'0' = Bit is cleared
		x = Bit is unknown

bit 7	<p><b>SMP:</b> Slew Rate Control bit</p> <p><u>In Master or Slave mode:</u></p> <p>1 = Slew rate control disabled for standard Speed mode (100 kHz and 1 MHz)</p> <p>0 = Slew rate control enabled for High-Speed mode (400 kHz)</p>
bit 6	<p><b>CKE:</b> SMBus Select bit</p> <p><u>In Master or Slave mode:</u></p> <p>1 = Enable SMBus specific inputs</p> <p>0 = Disable SMBus specific inputs</p>
bit 5	<p><b>D/A:</b> Data/Address bit</p> <p><u>In Master mode:</u></p> <p>Reserved.</p> <p><u>In Slave mode:</u></p> <p>1 = Indicates that the last byte received or transmitted was data</p> <p>0 = Indicates that the last byte received was an address</p>
bit 4	<p><b>P:</b> Stop bit<sup>(1)</sup></p> <p>1 = Indicates that a Stop bit has been detected last</p> <p>0 = Stop bit was not detected last</p>
bit 3	<p><b>S:</b> Start bit<sup>(1)</sup></p> <p>1 = Indicates that a Start bit has been detected last</p> <p>0 = Start bit was not detected last</p>
bit 2	<p><b>R/W:</b> Read/Write Information bit (I<sup>2</sup>C mode only)<sup>(2, 3)</sup></p> <p><u>In Slave mode:</u></p> <p>1 = Read</p> <p>0 = Write</p> <p><u>In Master mode:</u></p> <p>1 = Transmit is in progress</p> <p>0 = Transmit is not in progress</p>
bit 1	<p><b>UA:</b> Update Address bit (10-bit Slave mode only)</p> <p>1 = Indicates that the user needs to update the address in the SSPADD register</p> <p>0 = Address does not need to be updated</p>
bit 0	<p><b>BF:</b> Buffer Full Status bit</p> <p><u>In Transmit mode:</u></p> <p>1 = SSPBUF is full</p> <p>0 = SSPBUF is empty</p> <p><u>In Receive mode:</u></p> <p>1 = SSPBUF is full (does not include the <math>\overline{\text{ACK}}</math> and Stop bits)</p> <p>0 = SSPBUF is empty (does not include the <math>\overline{\text{ACK}}</math> and Stop bits)</p>

- Note 1:** This bit is cleared on Reset and when SSPEN is cleared.
- 2:** This bit holds the R/W bit information following the last address match. This bit is only valid from the address match to the next Start bit, Stop bit or not  $\overline{\text{ACK}}$  bit.
- 3:** ORing this bit with SEN, RSEN, PEN, RCEN or ACKEN will indicate if the Master mode is active.

# PIC18(L)F1XK22

## REGISTER 14-4: SSPCON1: MSSP CONTROL 1 REGISTER (I<sup>2</sup>C MODE)

R/W-0	R/W-0	R/W-0	R/W-0	R/W-0	R/W-0	R/W-0	R/W-0
WCOL	SSPOV	SSPEN	CKP	SSPM3	SSPM2	SSPM1	SSPM0
bit 7							bit 0

### Legend:

R = Readable bit

W = Writable bit

U = Unimplemented bit, read as '0'

-n = Value at POR

'1' = Bit is set

'0' = Bit is cleared

x = Bit is unknown

- bit 7      **WCOL:** Write Collision Detect bit  
In Master Transmit mode:  
 1 = A write to the SSPBUF register was attempted while the I<sup>2</sup>C conditions were not valid for a transmission to be started (must be cleared by software)  
 0 = No collision  
In Slave Transmit mode:  
 1 = The SSPBUF register is written while it is still transmitting the previous word (must be cleared by software)  
 0 = No collision  
In Receive mode (Master or Slave modes):  
 This is a "don't care" bit.
- bit 6      **SSPOV:** Receive Overflow Indicator bit  
In Receive mode:  
 1 = A byte is received while the SSPBUF register is still holding the previous byte (must be cleared by software)  
 0 = No overflow  
In Transmit mode:  
 This is a "don't care" bit in Transmit mode.
- bit 5      **SSPEN:** Synchronous Serial Port Enable bit  
 1 = Enables the serial port and configures the SDA and SCL pins as the serial port pins  
 0 = Disables serial port and configures these pins as I/O port pins  
 When enabled, the SDA and SCL pins must be properly configured as inputs.
- bit 4      **CKP:** SCK Release Control bit  
In Slave mode:  
 1 = Release clock  
 0 = Holds clock low (clock stretch), used to ensure data setup time  
In Master mode:  
 Unused in this mode.
- bit 3-0    **SSPM<3:0>:** Synchronous Serial Port Mode Select bits  
 1111 = I<sup>2</sup>C Slave mode, 10-bit address with Start and Stop bit interrupts enabled  
 1110 = I<sup>2</sup>C Slave mode, 7-bit address with Start and Stop bit interrupts enabled  
 1011 = I<sup>2</sup>C Firmware Controlled Master mode (Slave Idle)  
 1000 = I<sup>2</sup>C Master mode, clock = F<sub>OSC</sub>/(4 \* (SSPADD + 1))  
 0111 = I<sup>2</sup>C Slave mode, 10-bit address  
 0110 = I<sup>2</sup>C Slave mode, 7-bit address  
 Bit combinations not specifically listed here are either reserved or implemented in SPI mode only.



## REGISTER 14-5: SSPCON2: MSSP CONTROL REGISTER (I<sup>2</sup>C MODE)

R/W-0	R/W-0	R/W-0	R/W-0	R/W-0	R/W-0	R/W-0	R/W-0
GCEN	ACKSTAT	ACKDT <sup>(2)</sup>	ACKEN <sup>(1)</sup>	RCEN <sup>(1)</sup>	PEN <sup>(1)</sup>	RSEN <sup>(1)</sup>	SEN <sup>(1)</sup>
bit 7							bit 0

### Legend:

R = Readable bit	W = Writable bit	U = Unimplemented bit, read as '0'
-n = Value at POR	'1' = Bit is set	'0' = Bit is cleared
		x = Bit is unknown

- bit 7      **GCEN:** General Call Enable bit (Slave mode only)  
 1 = Generate interrupt when a general call address 0x00 or 00h is received in the SSPSR  
 0 = General call address disabled
- bit 6      **ACKSTAT:** Acknowledge Status bit (Master Transmit mode only)  
 1 = Acknowledge was not received from slave  
 0 = Acknowledge was received from slave
- bit 5      **ACKDT:** Acknowledge Data bit (Master Receive mode only)<sup>(2)</sup>  
 1 = Not Acknowledge  
 0 = Acknowledge
- bit 4      **ACKEN:** Acknowledge Sequence Enable bit (Master Receive mode only)<sup>(1)</sup>  
 1 = Initiate Acknowledge sequence on SDA and SCL pins and transmit ACKDT data bit.  
         Automatically cleared by hardware.  
 0 = Acknowledge sequence Idle
- bit 3      **RCEN:** Receive Enable bit (Master mode only)<sup>(1)</sup>  
 1 = Enables Receive mode for I<sup>2</sup>C  
 0 = Receive Idle
- bit 2      **PEN:** Stop Condition Enable bit (Master mode only)<sup>(1)</sup>  
 1 = Initiate Stop condition on SDA and SCL pins. Automatically cleared by hardware.  
 0 = Stop condition Idle
- bit 1      **RSEN:** Repeated Start Condition Enable bit (Master mode only)<sup>(1)</sup>  
 1 = Initiate Repeated Start condition on SDA and SCL pins. Automatically cleared by hardware.  
 0 = Repeated Start condition Idle
- bit 0      **SEN:** Start Condition Enable/Stretch Enable bit<sup>(1)</sup>  
In Master mode:  
 1 = Initiate Start condition on SDA and SCL pins. Automatically cleared by hardware.  
 0 = Start condition Idle  
In Slave mode:  
 1 = Clock stretching is enabled for both slave transmit and slave receive (stretch enabled)  
 0 = Clock stretching is disabled

**Note 1:** For bits ACKEN, RCEN, PEN, RSEN, SEN: If the I<sup>2</sup>C module is not in the Idle mode, these bits may not be set (no spooling) and the SSPBUF may not be written (or writes to the SSPBUF are disabled).

**2:** Value that will be transmitted when the user initiates an Acknowledge sequence at the end of a receive.

# PIC18(L)F1XK22

## 14.3.2 OPERATION

The MSSP module functions are enabled by setting SSPEN bit of the SSPCON1 register.

The SSPCON1 register allows control of the I<sup>2</sup>C operation. Four mode selection bits of the SSPCON1 register allow one of the following I<sup>2</sup>C modes to be selected:

- I<sup>2</sup>C Master mode, clock = (Fosc/(4\*(SSPADD + 1)))
- I<sup>2</sup>C Slave mode (7-bit address)
- I<sup>2</sup>C Slave mode (10-bit address)
- I<sup>2</sup>C Slave mode (7-bit address) with Start and Stop bit interrupts enabled
- I<sup>2</sup>C Slave mode (10-bit address) with Start and Stop bit interrupts enabled
- I<sup>2</sup>C Firmware Controlled Master mode, slave is Idle

Selection of any I<sup>2</sup>C mode with the SSPEN bit set, forces the SCL and SDA pins to be open-drain, provided these pins are programmed to inputs by setting the appropriate TRIS bits

**Note:** To ensure proper operation of the module, pull-up resistors must be provided externally to the SCL and SDA pins.

## 14.3.3 SLAVE MODE

In Slave mode, the SCL and SDA pins must be configured as inputs. The MSSP module will override the input state with the output data when required (slave-transmitter).

The I<sup>2</sup>C Slave mode hardware will always generate an interrupt on an address match. Through the mode select bits, the user can also choose to interrupt on Start and Stop bits

When an address is matched, or the data transfer after an address match is received, the hardware automatically will generate the Acknowledge (ACK) pulse and load the SSPBUF register with the received value currently in the SSPSR register.

Any combination of the following conditions will cause the MSSP module not to give this ACK pulse:

- The Buffer Full bit, BF bit of the SSPSTAT register, is set before the transfer is received.
- The overflow bit, SSPOV bit of the SSPCON1 register, is set before the transfer is received.

In this case, the SSPSR register value is not loaded into the SSPBUF, but bit SSPIF of the PIR1 register is set. The BF bit is cleared by reading the SSPBUF register, while bit SSPOV is cleared through software.

The SCL clock input must have a minimum high and low for proper operation. The high and low times of the I<sup>2</sup>C specification, as well as the requirement of the MSSP module, are shown in [Section 25.0 “Electrical Specifications”](#).

## 14.3.3.1 Addressing

Once the MSSP module has been enabled, it waits for a Start condition to occur. Following the Start condition, the 8 bits are shifted into the SSPSR register. All incoming bits are sampled with the rising edge of the clock (SCL) line. The value of register SSPSR<7:1> is compared to the value of the SSPADD register. The address is compared on the falling edge of the eighth clock (SCL) pulse. If the addresses match and the BF and SSPOV bits are clear, the following events occur:

1. The SSPSR register value is loaded into the SSPBUF register.
2. The Buffer Full bit, BF, is set.
3. An ACK pulse is generated.
4. MSSP Interrupt Flag bit, SSPIF of the PIR1 register, is set (interrupt is generated, if enabled) on the falling edge of the ninth SCL pulse.

In 10-bit Address mode, two address bytes need to be received by the slave. The five Most Significant bits (MSBs) of the first address byte specify if this is a 10-bit address. Bit R/W of the SSPSTAT register must specify a write so the slave device will receive the second address byte. For a 10-bit address, the first byte would equal '11110 A9 A8 0', where 'A9' and 'A8' are the two MSBs of the address. The sequence of events for 10-bit address is as follows, with steps 7 through 9 for the slave-transmitter:

1. Receive first (high) byte of address (bits SSPIF, BF and UA of the SSPSTAT register are set).
2. Read the SSPBUF register (clears bit BF) and clear flag bit, SSPIF.
3. Update the SSPADD register with second (low) byte of address (clears bit UA and releases the SCL line).
4. Receive second (low) byte of address (bits SSPIF, BF and UA are set). If the address matches then the SCL is held until the next step. Otherwise the SCL line is not held.
5. Read the SSPBUF register (clears bit BF) and clear flag bit, SSPIF.
6. Update the SSPADD register with the first (high) byte of address. (This will clear bit UA and release a held SCL line.)
7. Receive Repeated Start condition.
8. Receive first (high) byte of address with R/W bit set (bits SSPIF, BF, R/W are set).
9. Read the SSPBUF register (clears bit BF) and clear flag bit, SSPIF.
10. Load SSPBUF with byte the slave is to transmit, sets the BF bit.
11. Set the CKP bit to release SCL.

## 14.3.3.2 Reception

When the  $\overline{R/W}$  bit of the address byte is clear and an address match occurs, the  $\overline{R/W}$  bit of the SSPSTAT register is cleared. The received address is loaded into the SSPBUF register and the SDA line is held low ( $\overline{ACK}$ ).

When the address byte overflow condition exists, then the no Acknowledge ( $\overline{ACK}$ ) pulse is given. An overflow condition is defined as either bit BF of the SSPSTAT register is set, or bit SSPOV of the SSPCON1 register is set.

An MSSP interrupt is generated for each data transfer byte. Flag bit, SSPIF of the PIR1 register, must be cleared by software.

When the SEN bit of the SSPCON2 register is set, SCL will be held low (clock stretch) following each data transfer. The clock must be released by setting the CKP bit of the SSPCON1 register. See [Section 14.3.4 “Clock Stretching”](#) for more detail.

## 14.3.3.3 Transmission

When the  $\overline{R/W}$  bit of the incoming address byte is set and an address match occurs, the  $\overline{R/W}$  bit of the SSPSTAT register is set. The received address is loaded into the SSPBUF register. The  $\overline{ACK}$  pulse will be sent on the ninth bit and pin SCK/SCL is held low regardless of SEN (see [Section 14.3.4 “Clock Stretching”](#) for more detail). By stretching the clock, the master will be unable to assert another clock pulse until the slave is done preparing the transmit data. The transmit data must be loaded into the SSPBUF register which also loads the SSPSR register. Then pin SCK/SCL should be released by setting the CKP bit of the SSPCON1 register. The eight data bits are shifted out on the falling edge of the SCL input. This ensures that the SDA signal is valid during the SCL high time ([Figure 14-9](#)).

The  $\overline{ACK}$  pulse from the master-receiver is latched on the rising edge of the ninth SCL input pulse. If the SDA line is high (not  $\overline{ACK}$ ), then the data transfer is complete. In this case, when the  $\overline{ACK}$  is latched by the slave, the slave logic is reset (resets SSPSTAT register) and the slave monitors for another occurrence of the Start bit. If the SDA line was low ( $\overline{ACK}$ ), the next transmit data must be loaded into the SSPBUF register. Again, pin SCK/SCL must be released by setting bit CKP.

An MSSP interrupt is generated for each data transfer byte. The SSPIF bit must be cleared by software and the SSPSTAT register is used to determine the status of the byte. The SSPIF bit is set on the falling edge of the ninth clock pulse.

FIGURE 14-8: I<sup>2</sup>C™ SLAVE MODE TIMING WITH SEN = 0 (RECEPTION, 7-BIT ADDRESS)

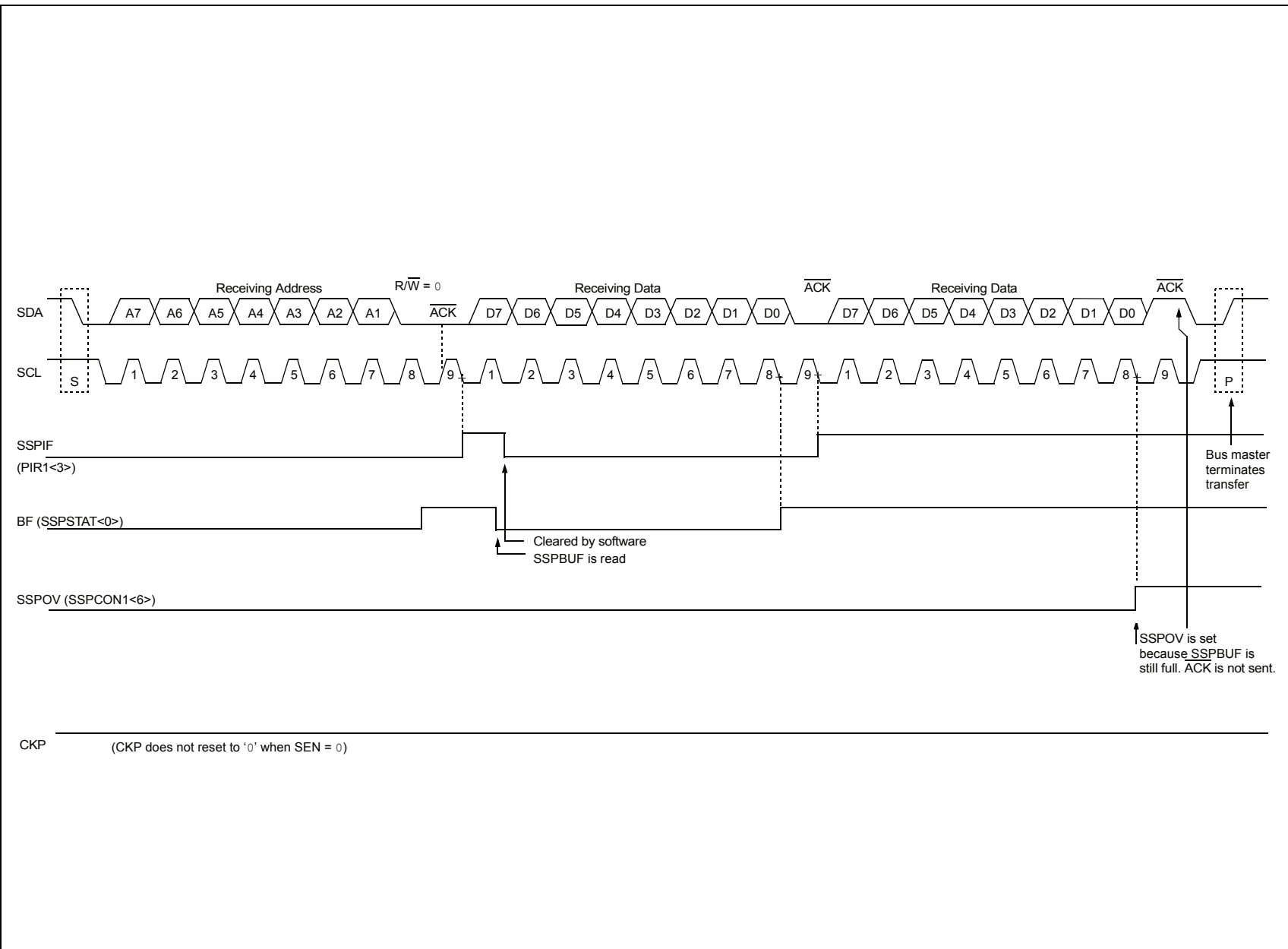


FIGURE 14-9: I<sup>2</sup>C™ SLAVE MODE TIMING (TRANSMISSION, 7-BIT ADDRESS)

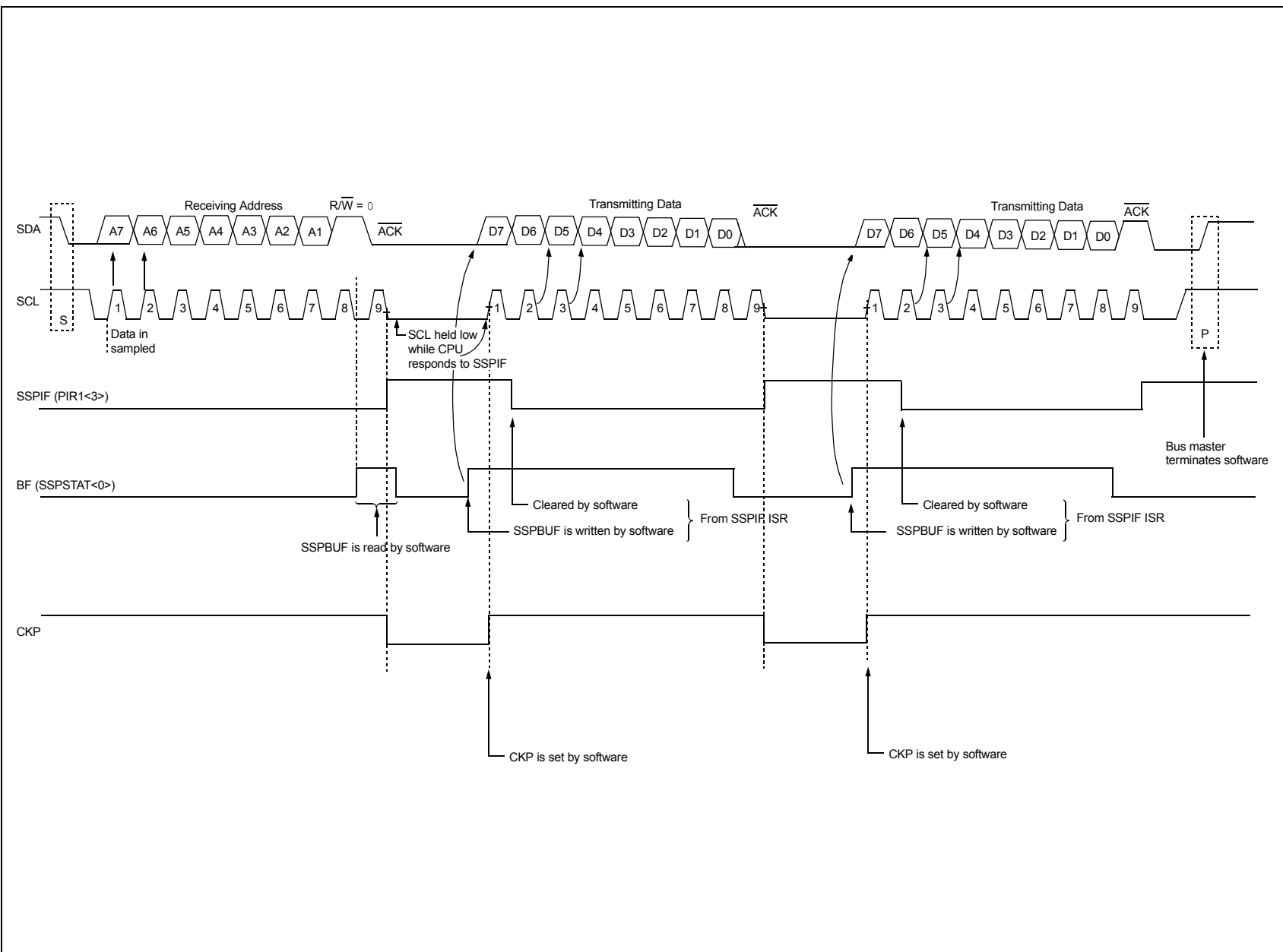


FIGURE 14-10: I<sup>2</sup>C™ SLAVE MODE TIMING WITH SEN = 0 (RECEPTION, 10-BIT ADDRESS)

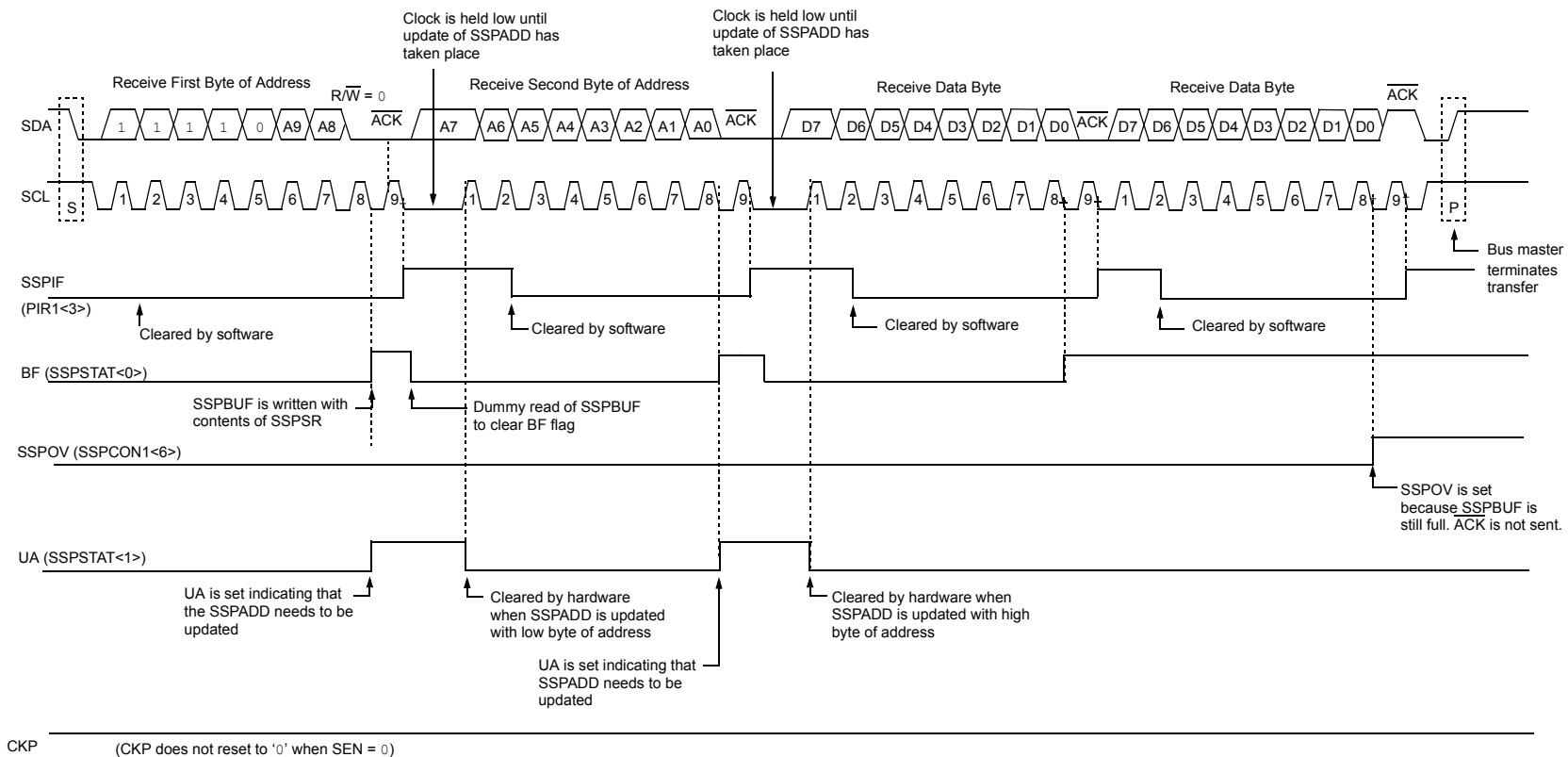
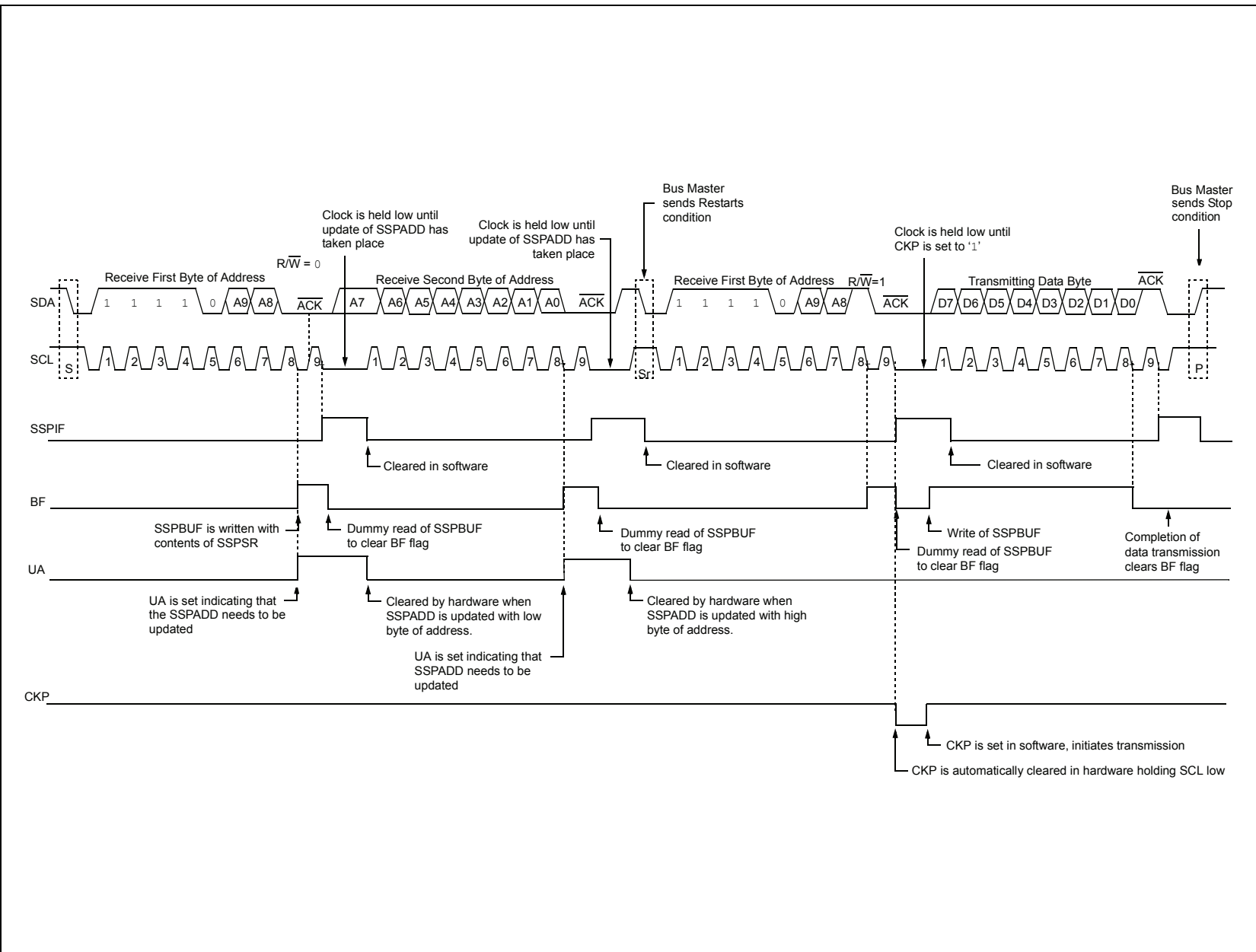


FIGURE 14-11: I<sup>2</sup>C™ SLAVE MODE TIMING (TRANSMISSION, 10-BIT ADDRESS)



# PIC18(L)F1XK22

## 14.3.3.4 SSP Mask Register

An SSP Mask (SSPMSK) register is available in I<sup>2</sup>C Slave mode as a mask for the value held in the SSPSR register during an address comparison operation. A zero ('0') bit in the SSPMSK register has the effect of making the corresponding bit in the SSPSR register a "don't care".

This register is reset to all '1's upon any Reset condition and, therefore, has no effect on standard SSP operation until written with a mask value.

This register must be initiated prior to setting SSPM<3:0> bits to select the I<sup>2</sup>C Slave mode (7-bit or 10-bit address).

The SSP Mask register is active during:

- 7-bit Address mode: address compare of A<7:1>.
- 10-bit Address mode: address compare of A<7:0> only. The SSP mask has no effect during the reception of the first (high) byte of the address.

### REGISTER 14-6: SSPMSK: SSP MASK REGISTER

R/W-1	R/W-1	R/W-1	R/W-1	R/W-1	R/W-1	R/W-1	R/W-1
MSK7	MSK6	MSK5	MSK4	MSK3	MSK2	MSK1	MSK0 <sup>(1)</sup>
bit 7							bit 0

#### Legend:

R = Readable bit

W = Writable bit

U = Unimplemented bit, read as '0'

-n = Value at POR

'1' = Bit is set

'0' = Bit is cleared

x = Bit is unknown

bit 7-1

**MSK<7:1>**: Mask bits

1 = The received address bit n is compared to SSPADD<n> to detect I<sup>2</sup>C address match

0 = The received address bit n is not used to detect I<sup>2</sup>C address match

bit 0

**MSK<0>**: Mask bit for I<sup>2</sup>C Slave mode, 10-bit Address<sup>(1)</sup>

I<sup>2</sup>C Slave mode, 10-bit Address (SSPM<3:0> = 0111):

1 = The received address bit 0 is compared to SSPADD<0> to detect I<sup>2</sup>C address match

0 = The received address bit 0 is not used to detect I<sup>2</sup>C address match

**Note 1:** The MSK0 bit is used only in 10-bit Slave mode. In all other modes, this bit has no effect.



## REGISTER 14-7: SSPADD: MSSP ADDRESS AND BAUD RATE REGISTER (I<sup>2</sup>C MODE)

R/W-0	R/W-0	R/W-0	R/W-0	R/W-0	R/W-0	R/W-0	R/W-0
ADD7	ADD6	ADD5	ADD4	ADD3	ADD2	ADD1	ADD0
bit 7							bit 0

### Legend:

R = Readable bit

W = Writable bit

U = Unimplemented bit, read as '0'

-n = Value at POR

'1' = Bit is set

'0' = Bit is cleared

x = Bit is unknown

### Master mode:

bit 7-0      **ADD<7:0>**: Baud Rate Clock Divider bits  
 SCL pin clock period = ((ADD<7:0> + 1) \* 4) / Fosc

### 10-Bit Slave mode — Most Significant Address Byte:

bit 7-3      **Not used:** Unused for Most Significant Address Byte. Bit state of this register is a "don't care." Bit pattern sent by master is fixed by I<sup>2</sup>C specification and must be equal to '11110'. However, those bits are compared by hardware and are not affected by the value in this register.

bit 2-1      **ADD<9:8>**: Two Most Significant bits of 10-bit address

bit 0      **Not used:** Unused in this mode. Bit state is a "don't care."

### 10-Bit Slave mode — Least Significant Address Byte:

bit 7-0      **ADD<7:0>**: Eight Least Significant bits of 10-bit address

### 7-Bit Slave mode:

bit 7-1      **ADD<6:0>**: 7-bit address

bit 0      **Not used:** Unused in this mode. Bit state is a "don't care."

# PIC18(L)F1XK22

## 14.3.4 CLOCK STRETCHING

Both 7-bit and 10-bit Slave modes implement automatic clock stretching during a transmit sequence.

The SEN bit of the SSPCON2 register allows clock stretching to be enabled during receives. Setting SEN will cause the SCL pin to be held low at the end of each data receive sequence.

### 14.3.4.1 Clock Stretching for 7-bit Slave Receive Mode (SEN = 1)

In 7-bit Slave Receive mode, on the falling edge of the ninth clock at the end of the ACK sequence if the BF bit is set, the CKP bit of the SSPCON1 register is automatically cleared, forcing the SCL output to be held low. The CKP being cleared to '0' will assert the SCL line low. The CKP bit must be set in the user's ISR before reception is allowed to continue. By holding the SCL line low, the user has time to service the ISR and read the contents of the SSPBUF before the master device can initiate another data transfer sequence. This will prevent buffer overruns from occurring (see [Figure 14-13](#)).

**Note 1:** If the user reads the contents of the SSPBUF before the falling edge of the ninth clock, thus clearing the BF bit, the CKP bit will not be cleared and clock stretching will not occur.

**2:** The CKP bit can be set by software regardless of the state of the BF bit. The user should be careful to clear the BF bit in the ISR before the next receive sequence in order to prevent an overflow condition.

### 14.3.4.2 Clock Stretching for 10-bit Slave Receive Mode (SEN = 1)

In 10-bit Slave Receive mode during the address sequence, clock stretching automatically takes place but CKP is not cleared. During this time, if the UA bit is set after the ninth clock, clock stretching is initiated. The UA bit is set after receiving the upper byte of the 10-bit address and following the receive of the second byte of the 10-bit address with the R/W bit cleared to '0'. The release of the clock line occurs upon updating SSPADD. Clock stretching will occur on each data receive sequence as described in 7-bit mode.

### 14.3.4.3 Clock Stretching for 7-bit Slave Transmit Mode

7-bit Slave Transmit mode implements clock stretching by clearing the CKP bit after the falling edge of the ninth clock. This occurs regardless of the state of the SEN bit.

The user's ISR must set the CKP bit before transmission is allowed to continue. By holding the SCL line low, the user has time to service the ISR and load the contents of the SSPBUF before the master device can initiate another data transfer sequence (see [Figure 14-9](#)).

**Note 1:** If the user loads the contents of SSPBUF, setting the BF bit before the falling edge of the ninth clock, the CKP bit will not be cleared and clock stretching will not occur.

**2:** The CKP bit can be set by software regardless of the state of the BF bit.

### 14.3.4.4 Clock Stretching for 10-bit Slave Transmit Mode

In 10-bit Slave Transmit mode, clock stretching is controlled during the first two address sequences by the state of the UA bit, just as it is in 10-bit Slave Receive mode. The first two addresses are followed by a third address sequence which contains the high-order bits of the 10-bit address and the R/W bit set to '1'. After the third address sequence is performed, the UA bit is not set, the module is now configured in Transmit mode and clock stretching is automatic with the hardware clearing CKP, as in 7-bit Slave Transmit mode (see [Figure 14-11](#)).

## 14.3.4.5 Clock Synchronization and the CKP bit

When the CKP bit is cleared, the SCL output is forced to '0'. However, clearing the CKP bit will not assert the SCL output low until the SCL output is already sampled low. Therefore, the CKP bit will not assert the SCL line until an external I<sup>2</sup>C master device has already asserted the SCL line. The SCL output will remain low until the CKP bit is set and all other devices on the I<sup>2</sup>C bus have deasserted SCL. This ensures that a write to the CKP bit will not violate the minimum high time requirement for SCL (see Figure 14-12).

**FIGURE 14-12: CLOCK SYNCHRONIZATION TIMING**

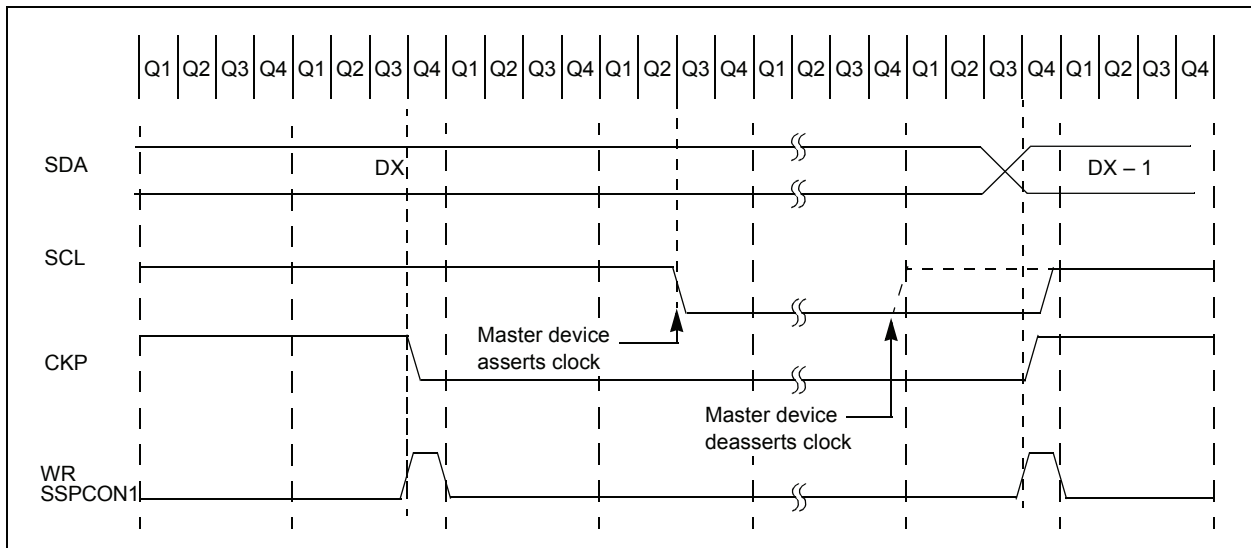
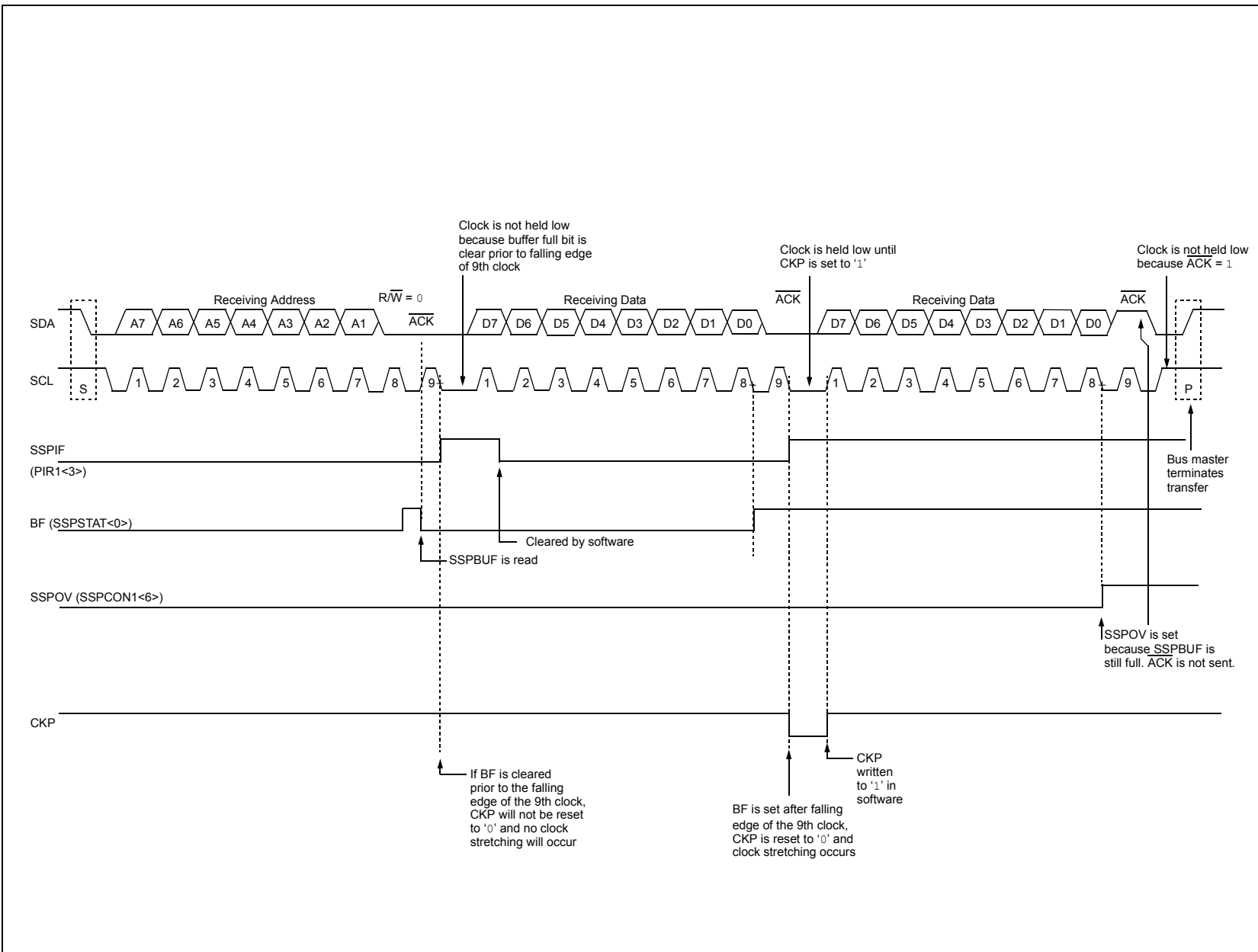
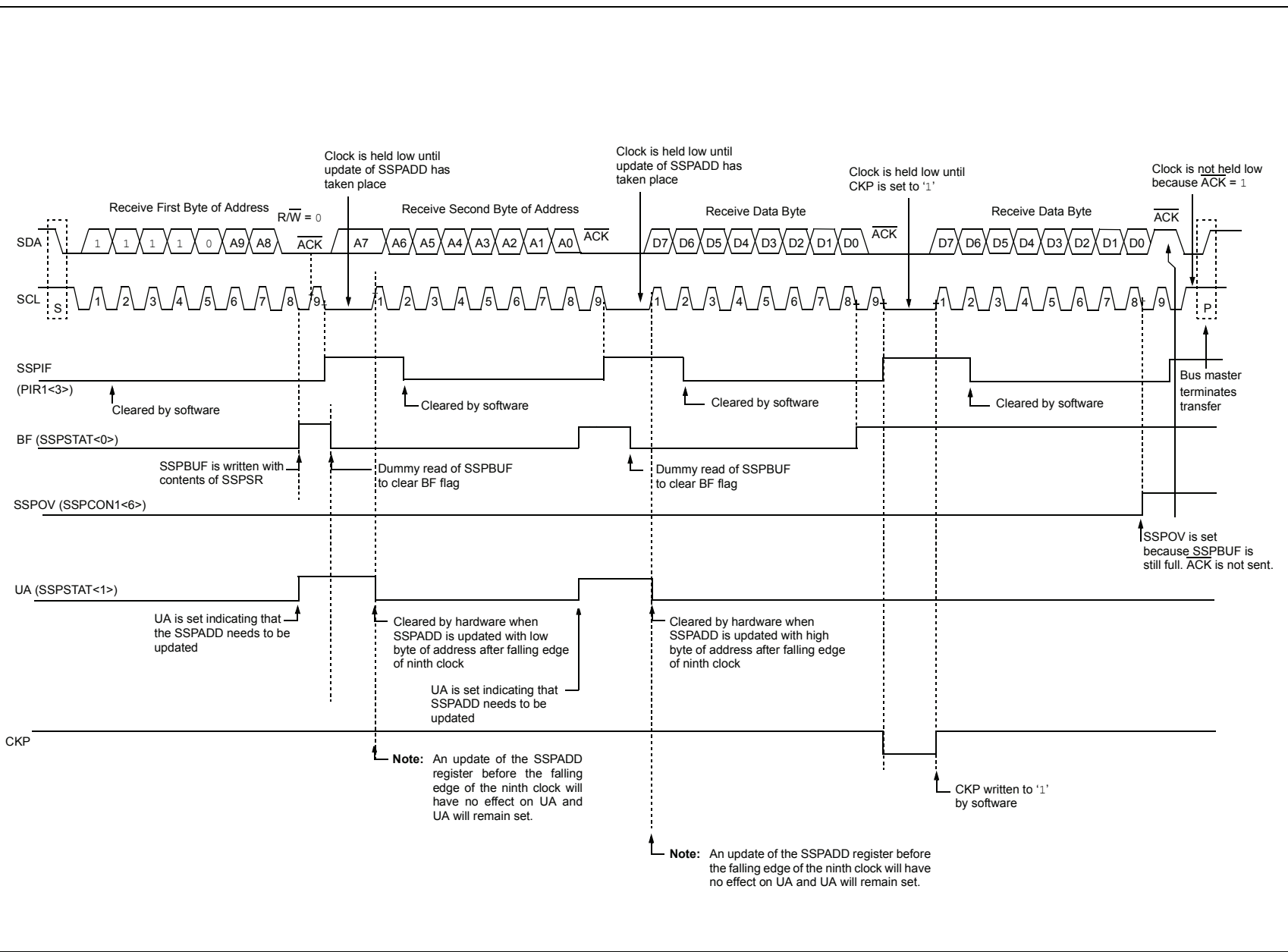


FIGURE 14-13: I<sup>2</sup>C™ SLAVE MODE TIMING WITH SEN = 1 (RECEPTION, 7-BIT ADDRESS)



**FIGURE 14-14: I<sup>2</sup>C™ SLAVE MODE TIMING WITH SEN = 1 (RECEPTION, 10-BIT ADDRESS)**



# PIC18(L)F1XK22

## 14.3.5 GENERAL CALL ADDRESS SUPPORT

The addressing procedure for the I<sup>2</sup>C bus is such that the first byte after the Start condition usually determines which device will be the slave addressed by the master. The exception is the general call address which can address all devices. When this address is used, all devices should, in theory, respond with an Acknowledge.

The general call address is one of eight addresses reserved for specific purposes by the I<sup>2</sup>C protocol. It consists of all '0's with R/W = 0.

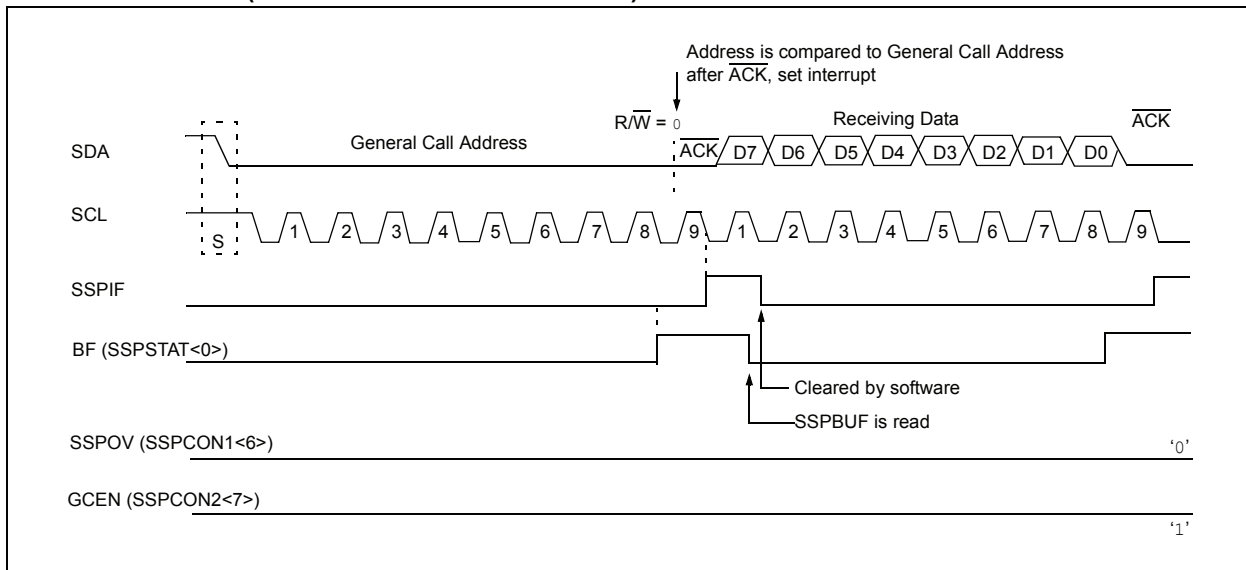
The general call address is recognized when the GCEN bit of the SSPCON2 is set. Following a Start bit detect, 8 bits are shifted into the SSPSR and the address is compared against the SSPADD. It is also compared to the general call address and fixed in hardware.

If the general call address matches, the SSPSR is transferred to the SSPBUF, the BF flag bit is set (eighth bit) and on the falling edge of the ninth bit ( $\overline{ACK}$  bit), the SSPIF interrupt flag bit is set.

When the interrupt is serviced, the source for the interrupt can be checked by reading the contents of the SSPBUF. The value can be used to determine if the address was device specific or a general call address.

In 10-bit mode, the SSPADD is required to be updated for the second half of the address to match and the UA bit of the SSPSTAT register is set. If the general call address is sampled when the GCEN bit is set, while the slave is configured in 10-bit Address mode, then the second half of the address is not necessary, the UA bit will not be set and the slave will begin receiving data after the Acknowledge (Figure 14-15).

**FIGURE 14-15: SLAVE MODE GENERAL CALL ADDRESS SEQUENCE (7 OR 10-BIT ADDRESS MODE)**



## 14.3.6 MASTER MODE

Master mode is enabled by setting and clearing the appropriate SSPM bits in SSPCON1 and by setting the SSPEN bit. In Master mode, the SCL and SDA lines are manipulated by the MSSP hardware.

Master mode of operation is supported by interrupt generation on the detection of the Start and Stop conditions. The Stop (P) and Start (S) bits are cleared from a Reset or when the MSSP module is disabled. Control of the I<sup>2</sup>C bus may be taken when the P bit is set, or the bus is Idle, with both the S and P bits clear.

In Firmware Controlled Master mode, user code conducts all I<sup>2</sup>C bus operations based on Start and Stop bit conditions.

Once Master mode is enabled, the user has six options.

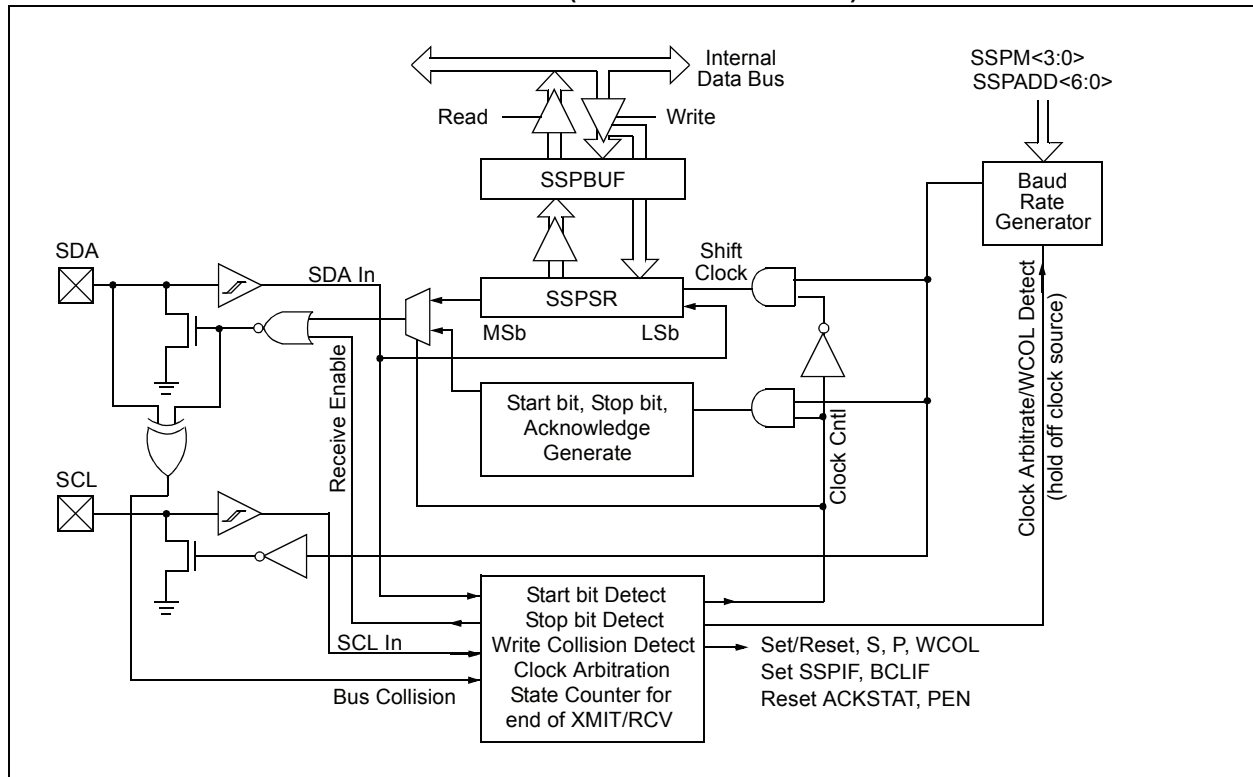
1. Assert a Start condition on SDA and SCL.
2. Assert a Repeated Start condition on SDA and SCL.
3. Write to the SSPBUF register initiating transmission of data/address.
4. Configure the I<sup>2</sup>C port to receive data.
5. Generate an Acknowledge condition at the end of a received byte of data.
6. Generate a Stop condition on SDA and SCL.

**Note:** The MSSP module, when configured in I<sup>2</sup>C Master mode, does not allow queueing of events. For instance, the user is not allowed to initiate a Start condition and immediately write the SSPBUF register to initiate transmission before the Start condition is complete. In this case, the SSPBUF will not be written to and the WCOL bit will be set, indicating that a write to the SSPBUF did not occur.

The following events will cause the SSP Interrupt Flag bit, SSPIF, to be set (SSP interrupt, if enabled):

- Start condition
- Stop condition
- Data transfer byte transmitted/received
- Acknowledge transmit
- Repeated Start

**FIGURE 14-16: MSSP BLOCK DIAGRAM (I<sup>2</sup>C™ MASTER MODE)**



# PIC18(L)F1XK22

---

## 14.3.6.1 I<sup>2</sup>C Master Mode Operation

The master device generates all of the serial clock pulses and the Start and Stop conditions. A transfer is ended with a Stop condition or with a Repeated Start condition. Since the Repeated Start condition is also the beginning of the next serial transfer, the I<sup>2</sup>C bus will not be released.

In Master Transmitter mode, serial data is output through SDA, while SCL outputs the serial clock. The first byte transmitted contains the slave address of the receiving device (7 bits) and the Read/Write (R/W) bit. In this case, the R/W bit will be logic '0'. Serial data is transmitted 8 bits at a time. After each byte is transmitted, an Acknowledge bit is received. Start and Stop conditions are output to indicate the beginning and the end of a serial transfer.

In Master Receive mode, the first byte transmitted contains the slave address of the transmitting device (7 bits) and the R/W bit. In this case, the R/W bit will be logic '1'. Thus, the first byte transmitted is a 7-bit slave address followed by a '1' to indicate the receive bit. Serial data is received via SDA, while SCL outputs the serial clock. Serial data is received 8 bits at a time. After each byte is received, an Acknowledge bit is transmitted. Start and Stop conditions indicate the beginning and end of transmission.

A Baud Rate Generator is used to set the clock frequency output on SCL. See [Section 14.3.7 “Baud Rate”](#) for more detail.

A typical transmit sequence would go as follows:

1. The user generates a Start condition by setting the SEN bit of the SSPCON2 register.
2. SSPIF is set. The MSSP module will wait the required start time before any other operation takes place.
3. The user loads the SSPBUF with the slave address to transmit.
4. Address is shifted out the SDA pin until all 8 bits are transmitted.
5. The MSSP module shifts in the  $\overline{\text{ACK}}$  bit from the slave device and writes its value into the ACKSTAT bit of the SSPCON2 register.
6. The MSSP module generates an interrupt at the end of the ninth clock cycle by setting the SSPIF bit.
7. The user loads the SSPBUF with eight bits of data.
8. Data is shifted out the SDA pin until all 8 bits are transmitted.
9. The MSSP module shifts in the  $\overline{\text{ACK}}$  bit from the slave device and writes its value into the ACKSTAT bit of the SSPCON2 register.
10. The MSSP module generates an interrupt at the end of the ninth clock cycle by setting the SSPIF bit.
11. The user generates a Stop condition by setting the PEN bit of the SSPCON2 register.
12. Interrupt is generated once the Stop condition is complete.



## 14.3.7 BAUD RATE

In I<sup>2</sup>C Master mode, the Baud Rate Generator (BRG) reload value is placed in the SSPADD register (Figure 14-17). When a write occurs to SSPBUF, the Baud Rate Generator will automatically begin counting.

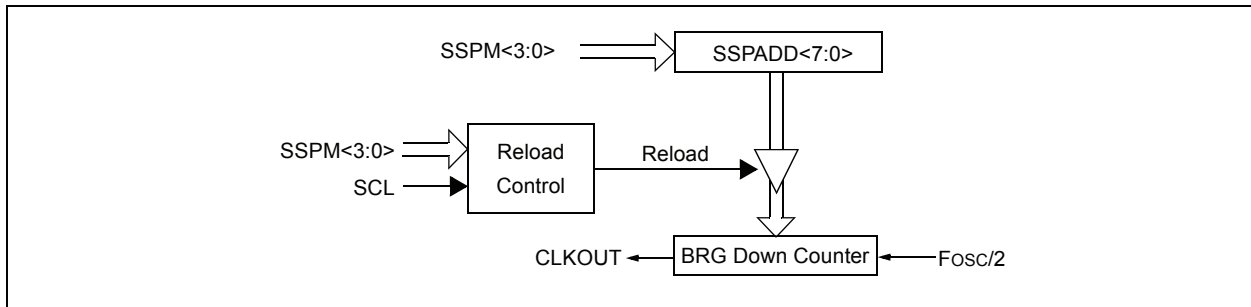
Once the given operation is complete (i.e., transmission of the last data bit is followed by ACK), the internal clock will automatically stop counting and the SCL pin will remain in its last state.

Table 14-3 demonstrates clock rates based on instruction cycles and the BRG value loaded into SSPADD.

**EQUATION 14-1:**

$$F_{SCL} = \frac{F_{OSC}}{(SSPADD + 1)(4)}$$

**FIGURE 14-17: BAUD RATE GENERATOR BLOCK DIAGRAM**



**TABLE 14-3: I<sup>2</sup>C™ CLOCK RATE W/BRG**

Fosc	Fcy	BRG Value	Fscl (2 Rollovers of BRG)
48 MHz	12 MHz	0Bh	1 MHz <sup>(1)</sup>
48 MHz	12 MHz	1Dh	400 kHz
48 MHz	12 MHz	77h	100 kHz
40 MHz	10 MHz	18h	400 kHz <sup>(1)</sup>
40 MHz	10 MHz	1Fh	312.5 kHz
40 MHz	10 MHz	63h	100 kHz
16 MHz	4 MHz	09h	400 kHz <sup>(1)</sup>
16 MHz	4 MHz	0Ch	308 kHz
16 MHz	4 MHz	27h	100 kHz
4 MHz	1 MHz	02h	333 kHz <sup>(1)</sup>
4 MHz	1 MHz	09h	100 kHz
4 MHz	1 MHz	00h	1 MHz <sup>(1)</sup>

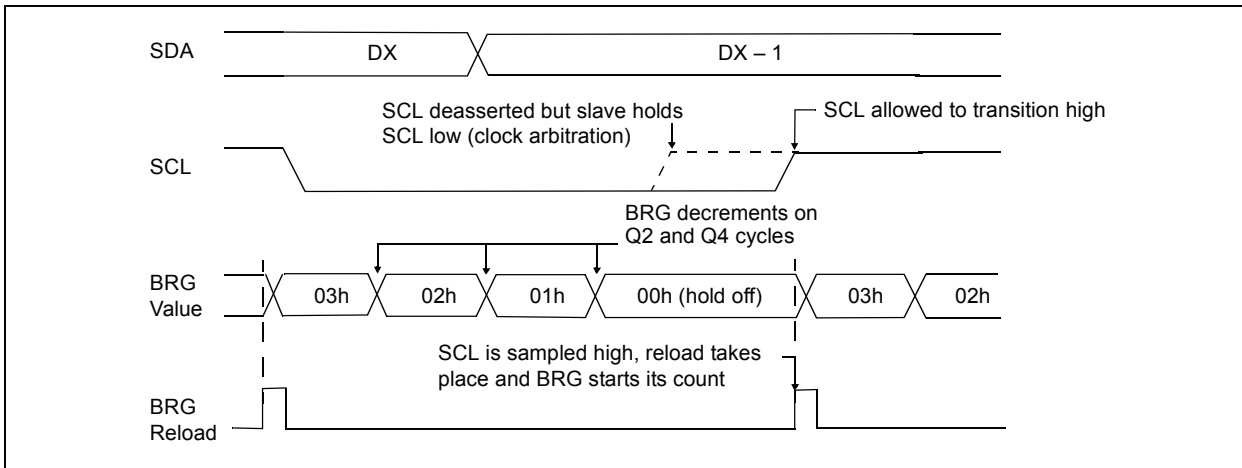
**Note 1:** The I<sup>2</sup>C interface does not conform to the 400 kHz I<sup>2</sup>C specification (which applies to rates greater than 100 kHz) in all details, but may be used with care where higher rates are required by the application.

# PIC18(L)F1XK22

## 14.3.7.1 Clock Arbitration

Clock arbitration occurs when the master, during any receive, transmit or Repeated Start/Stop condition, deasserts the SCL pin (SCL allowed to float high). When the SCL pin is allowed to float high, the Baud Rate Generator (BRG) is suspended from counting until the SCL pin is actually sampled high. When the SCL pin is sampled high, the Baud Rate Generator is reloaded with the contents of SSPADD<6:0> and begins counting. This ensures that the SCL high time will always be at least one BRG rollover count in the event that the clock is held low by an external device (Figure 14-18).

**FIGURE 14-18: BAUD RATE GENERATOR TIMING WITH CLOCK ARBITRATION**



## 14.3.8 I<sup>2</sup>C MASTER MODE START CONDITION TIMING

To initiate a Start condition, the user sets the Start Enable bit, SEN bit of the SSPCON2 register. If the SDA and SCL pins are sampled high, the Baud Rate Generator is reloaded with the contents of SSPADD<6:0> and starts its count. If SCL and SDA are both sampled high when the Baud Rate Generator times out (TBRG), the SDA pin is driven low. The action of the SDA being driven low while SCL is high is the Start condition and causes the S bit of the SSPSTAT1 register to be set. Following this, the Baud Rate Generator is reloaded with the contents of SSPADD<7:0> and resumes its count. When the Baud Rate Generator times out (TBRG), the SEN bit of the SSPCON2 register will be automatically cleared by hardware; the Baud Rate Generator is suspended, leaving the SDA line held low and the Start condition is complete.

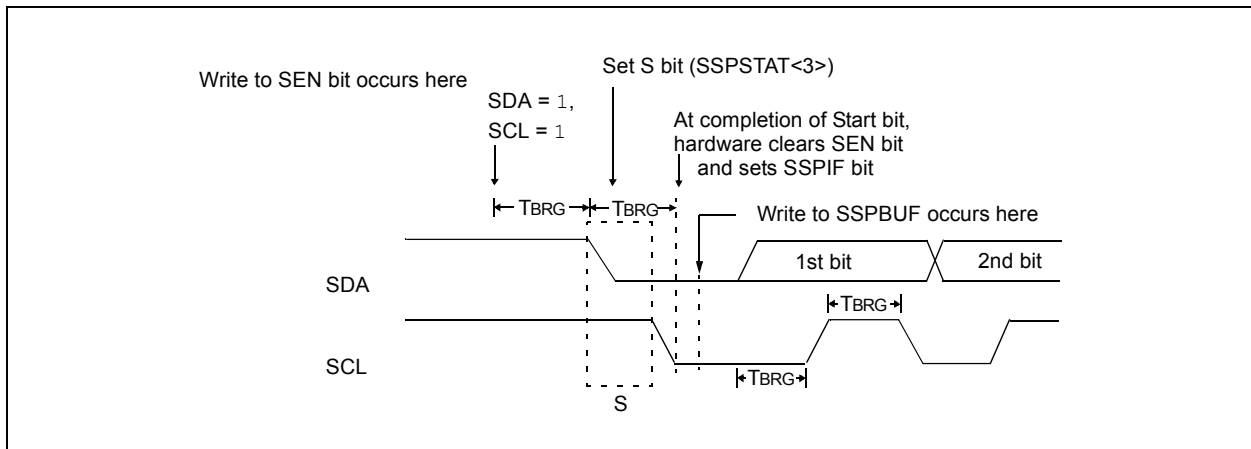
**Note:** If at the beginning of the Start condition, the SDA and SCL pins are already sampled low, or if during the Start condition, the SCL line is sampled low before the SDA line is driven low, a bus collision occurs, the Bus Collision Interrupt Flag, BCLIF, is set, the Start condition is aborted and the I<sup>2</sup>C module is reset into its Idle state.

### 14.3.8.1 WCOL Status Flag

If the user writes the SSPBUF when a Start sequence is in progress, the WCOL is set and the contents of the buffer are unchanged (the write doesn't occur).

**Note:** Because queueing of events is not allowed, writing to the lower 5 bits of SSPCON2 is disabled until the Start condition is complete.

**FIGURE 14-19: FIRST START BIT TIMING**





## 14.3.10 I<sup>2</sup>C MASTER MODE TRANSMISSION

Transmission of a data byte, a 7-bit address or the other half of a 10-bit address is accomplished by simply writing a value to the SSPBUF register. This action will set the Buffer Full flag bit, BF, and allow the Baud Rate Generator to begin counting and start the next transmission. Each bit of address/data will be shifted out onto the SDA pin after the falling edge of SCL is asserted (see data hold time specification parameter SP106). SCL is held low for one Baud Rate Generator rollover count (TBRG). Data should be valid before SCL is released high (see data setup time specification parameter SP107). When the SCL pin is released high, it is held that way for TBRG. The data on the SDA pin must remain stable for that duration and some hold time after the next falling edge of SCL. After the eighth bit is shifted out (the falling edge of the eighth clock), the BF flag is cleared and the master releases SDA. This allows the slave device being addressed to respond with an  $\overline{\text{ACK}}$  bit during the ninth bit time if an address match occurred, or if data was received properly. The status of ACK is written into the ACKDT bit on the falling edge of the ninth clock. If the master receives an Acknowledge, the Acknowledge Status bit, ACKSTAT, is cleared. If not, the bit is set. After the ninth clock, the SSPIF bit is set and the master clock (Baud Rate Generator) is suspended until the next data byte is loaded into the SSPBUF, leaving SCL low and SDA unchanged (Figure 14-21).

After the write to the SSPBUF, each bit of the address will be shifted out on the falling edge of SCL until all seven address bits and the R/W bit are completed. On the falling edge of the eighth clock, the master will deassert the SDA pin, allowing the slave to respond with an Acknowledge. On the falling edge of the ninth clock, the master will sample the SDA pin to see if the address was recognized by a slave. The status of the ACK bit is loaded into the ACKSTAT Status bit of the SSPCON2 register. Following the falling edge of the ninth clock transmission of the address, the SSPIF is set, the BF flag is cleared and the Baud Rate Generator is turned off until another write to the SSPBUF takes place, holding SCL low and allowing SDA to float.

### 14.3.10.1 BF Status Flag

In Transmit mode, the BF bit of the SSPSTAT register is set when the CPU writes to SSPBUF and is cleared when all 8 bits are shifted out.

### 14.3.10.2 WCOL Status Flag

If the user writes the SSPBUF when a transmit is already in progress (i.e., SSPSR is still shifting out a data byte), the WCOL is set and the contents of the buffer are unchanged (the write doesn't occur).

WCOL must be cleared by software before the next transmission.

### 14.3.10.3 ACKSTAT Status Flag

In Transmit mode, the ACKSTAT bit of the SSPCON2 register is cleared when the slave has sent an Acknowledge (ACK = 0) and is set when the slave does not Acknowledge (ACK = 1). A slave sends an Acknowledge when it has recognized its address (including a general call), or when the slave has properly received its data.

## 14.3.11 I<sup>2</sup>C MASTER MODE RECEPTION

Master mode reception is enabled by programming the Receive Enable bit, RCEN bit of the SSPCON2 register.

<b>Note:</b> The MSSP module must be in an Idle state before the RCEN bit is set or the RCEN bit will be disregarded.
---

The Baud Rate Generator begins counting and on each rollover, the state of the SCL pin changes (high-to-low/low-to-high) and data is shifted into the SSPSR. After the falling edge of the eighth clock, the receive enable flag is automatically cleared, the contents of the SSPSR are loaded into the SSPBUF, the BF flag bit is set, the SSPIF flag bit is set and the Baud Rate Generator is suspended from counting, holding SCL low. The MSSP is now in Idle state awaiting the next command. When the buffer is read by the CPU, the BF flag bit is automatically cleared. The user can then send an Acknowledge bit at the end of reception by setting the Acknowledge Sequence Enable, ACKEN bit of the SSPCON2 register.

### 14.3.11.1 BF Status Flag

In receive operation, the BF bit is set when an address or data byte is loaded into SSPBUF from SSPSR. It is cleared when the SSPBUF register is read.

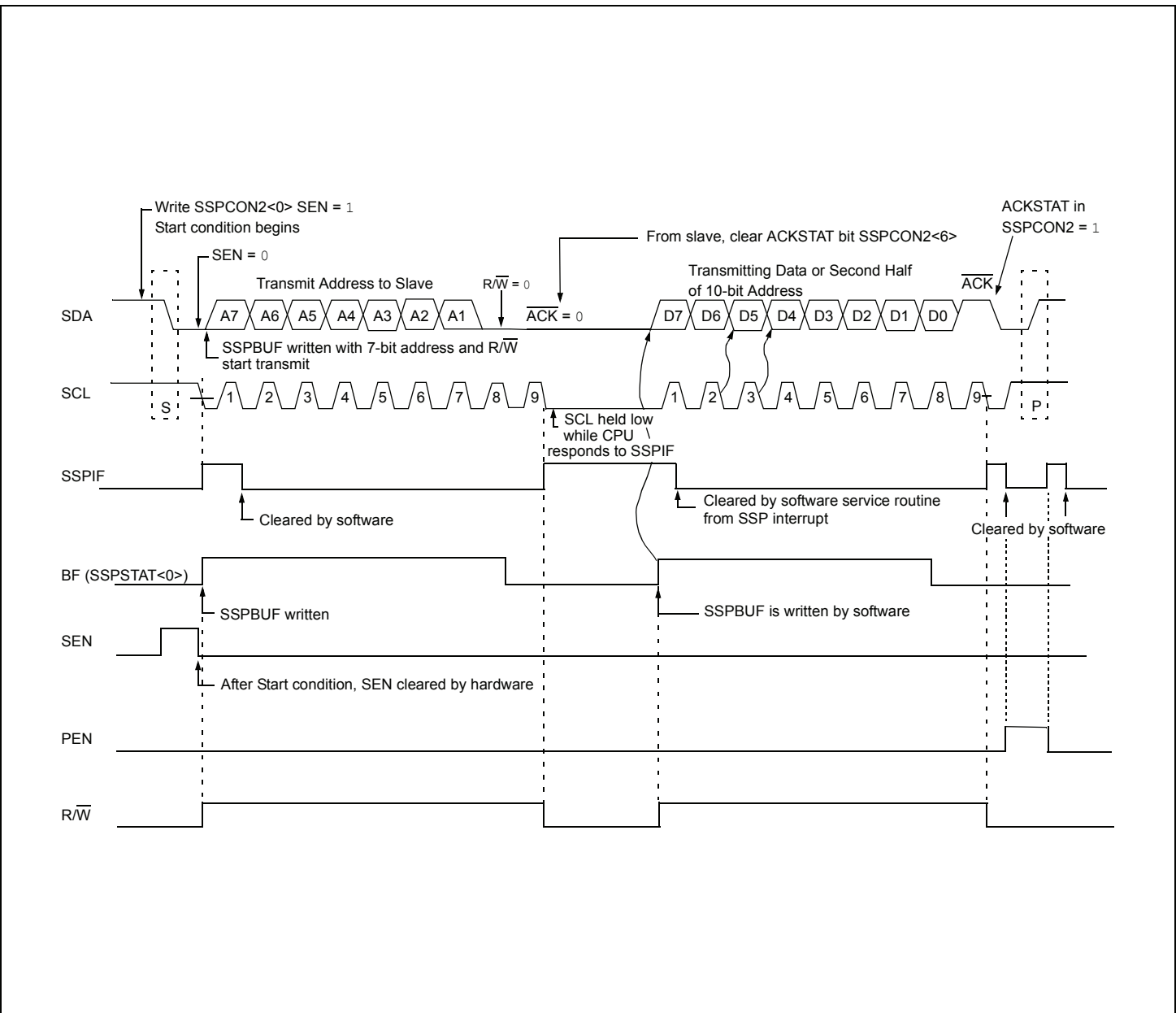
### 14.3.11.2 SSPOV Status Flag

In receive operation, the SSPOV bit is set when 8 bits are received into the SSPSR and the BF flag bit is already set from a previous reception.

### 14.3.11.3 WCOL Status Flag

If the user writes the SSPBUF when a receive is already in progress (i.e., SSPSR is still shifting in a data byte), the WCOL bit is set and the contents of the buffer are unchanged (the write doesn't occur).

FIGURE 14-21: I<sup>2</sup>C™ MASTER MODE WAVEFORM (TRANSMISSION, 7 OR 10-BIT ADDRESS)



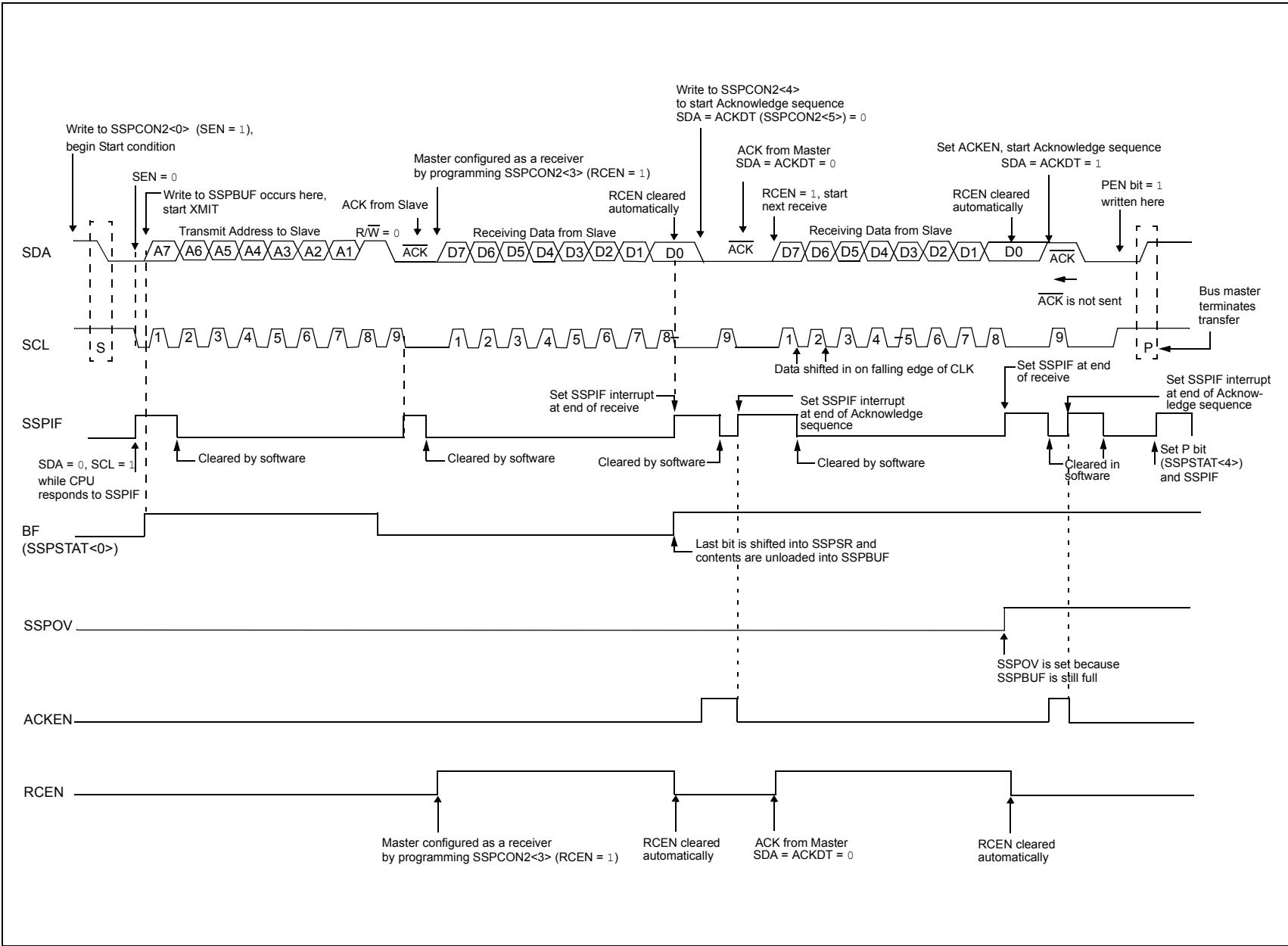


FIGURE 14-22: I<sup>2</sup>C™ MASTER MODE WAVEFORM (RECEPTION, 7-BIT ADDRESS)

# PIC18(L)F1XK22

## 14.3.12 ACKNOWLEDGE SEQUENCE TIMING

An Acknowledge sequence is enabled by setting the Acknowledge Sequence Enable bit, ACKEN bit of the SSPCON2 register. When this bit is set, the SCL pin is pulled low and the contents of the Acknowledge data bit are presented on the SDA pin. If the user wishes to generate an Acknowledge, then the ACKDT bit should be cleared. If not, the user should set the ACKDT bit before starting an Acknowledge sequence. The Baud Rate Generator then counts for one rollover period (TBRG) and the SCL pin is deasserted (pulled high). When the SCL pin is sampled high (clock arbitration), the Baud Rate Generator counts for TBRG. The SCL pin is then pulled low. Following this, the ACKEN bit is automatically cleared, the Baud Rate Generator is turned off and the MSSP module then goes into Idle mode (Figure 14-23).

### 14.3.12.1 WCOL Status Flag

If the user writes the SSPBUF when an Acknowledge sequence is in progress, then WCOL is set and the contents of the buffer are unchanged (the write doesn't occur).

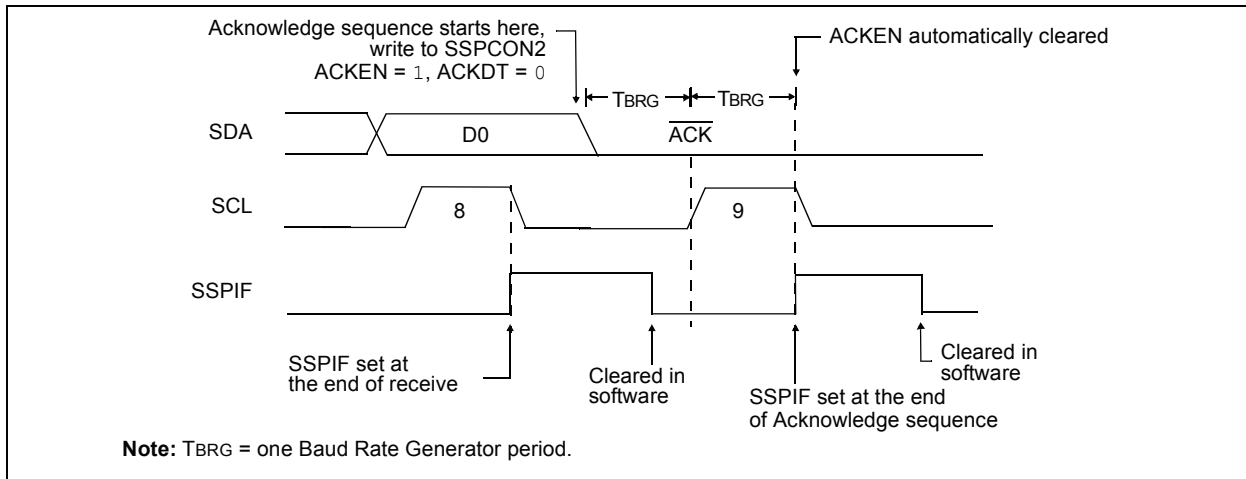
## 14.3.13 STOP CONDITION TIMING

A Stop bit is asserted on the SDA pin at the end of a receive/transmit by setting the Stop Sequence Enable bit, PEN bit of the SSPCON2 register. At the end of a receive/transmit, the SCL line is held low after the falling edge of the ninth clock. When the PEN bit is set, the master will assert the SDA line low. When the SDA line is sampled low, the Baud Rate Generator is reloaded and counts down to '0'. When the Baud Rate Generator times out, the SCL pin will be brought high and one TBRG (Baud Rate Generator rollover count) later, the SDA pin will be deasserted. When the SDA pin is sampled high while SCL is high, the P bit of the SSPSTAT register is set. A TBRG later, the PEN bit is cleared and the SSPIF bit is set (Figure 14-24).

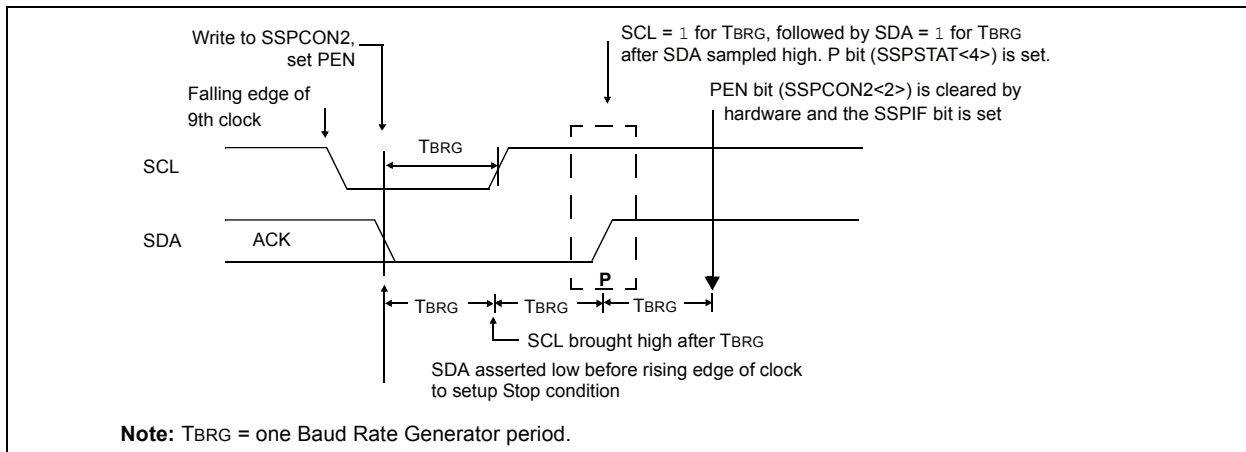
### 14.3.13.1 WCOL Status Flag

If the user writes the SSPBUF when a Stop sequence is in progress, then the WCOL bit is set and the contents of the buffer are unchanged (the write doesn't occur).

**FIGURE 14-23: ACKNOWLEDGE SEQUENCE WAVEFORM**



**FIGURE 14-24: STOP CONDITION RECEIVE OR TRANSMIT MODE**





## 14.3.14 SLEEP OPERATION

While in Sleep mode, the I<sup>2</sup>C Slave module can receive addresses or data and when an address match or complete byte transfer occurs, wake the processor from Sleep (if the MSSP interrupt is enabled).

## 14.3.15 EFFECTS OF A RESET

A Reset disables the MSSP module and terminates the current transfer.

## 14.3.16 MULTI-MASTER MODE

In Multi-Master mode, the interrupt generation on the detection of the Start and Stop conditions allows the determination of when the bus is free. The Stop (P) and Start (S) bits are cleared from a Reset or when the MSSP module is disabled. Control of the I<sup>2</sup>C bus may be taken when the P bit of the SSPSTAT register is set, or the bus is Idle, with both the S and P bits clear. When the bus is busy, enabling the SSP interrupt will generate the interrupt when the Stop condition occurs.

In multi-master operation, the SDA line must be monitored for arbitration to see if the signal level is the expected output level. This check is performed by hardware with the result placed in the BCLIF bit.

The states where arbitration can be lost are:

- Address Transfer
- Data Transfer
- A Start Condition
- A Repeated Start Condition
- An Acknowledge Condition

## 14.3.17 MULTI-MASTER COMMUNICATION, BUS COLLISION AND BUS ARBITRATION

Multi-Master mode support is achieved by bus arbitration. When the master outputs address/data bits onto the SDA pin, arbitration takes place when the master outputs a '1' on SDA, by letting SDA float high and another master asserts a '0'. When the SCL pin floats high, data should be stable. If the expected data on SDA is a '1' and the data sampled on the SDA pin = 0, then a bus collision has taken place. The master will set the Bus Collision Interrupt Flag, BCLIF and reset the I<sup>2</sup>C port to its Idle state (Figure 14-25).

If a transmit was in progress when the bus collision occurred, the transmission is halted, the BF flag is cleared, the SDA and SCL lines are deasserted and the SSPBUF can be written to. When the user services the bus collision Interrupt Service Routine and if the I<sup>2</sup>C bus is free, the user can resume communication by asserting a Start condition.

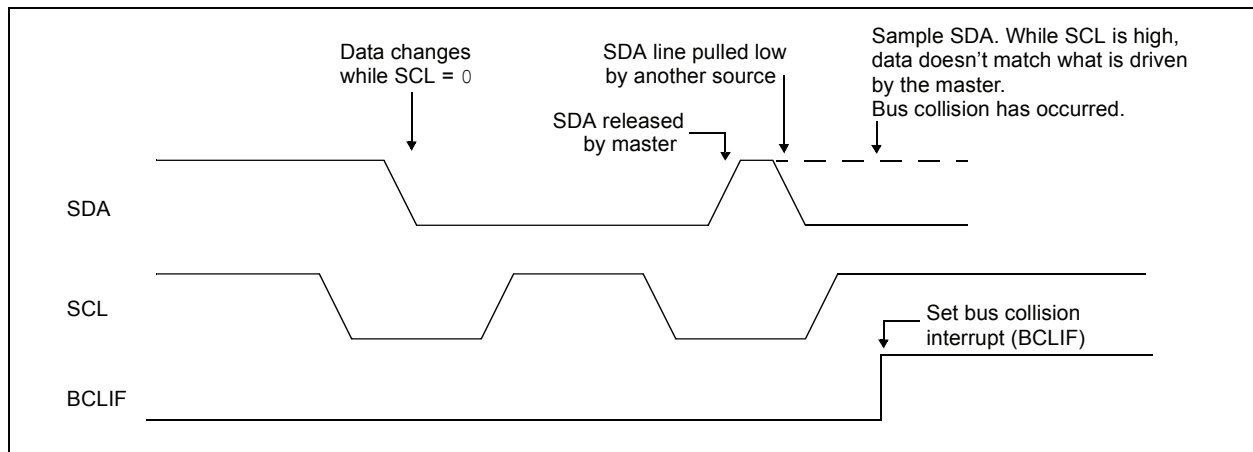
If a Start, Repeated Start, Stop or Acknowledge condition was in progress when the bus collision occurred, the condition is aborted, the SDA and SCL lines are deasserted and the respective control bits in the SSPCON2 register are cleared. When the user services the bus collision Interrupt Service Routine and if the I<sup>2</sup>C bus is free, the user can resume communication by asserting a Start condition.

The master will continue to monitor the SDA and SCL pins. If a Stop condition occurs, the SSPIF bit will be set.

A write to the SSPBUF will start the transmission of data at the first data bit, regardless of where the transmitter left off when the bus collision occurred.

In Multi-Master mode, the interrupt generation on the detection of Start and Stop conditions allows the determination of when the bus is free. Control of the I<sup>2</sup>C bus can be taken when the P bit is set in the SSPSTAT register, or the bus is Idle and the S and P bits are cleared.

**FIGURE 14-25: BUS COLLISION TIMING FOR TRANSMIT AND ACKNOWLEDGE**



# PIC18(L)F1XK22

## 14.3.17.1 Bus Collision During a Start Condition

During a Start condition, a bus collision occurs if:

- SDA or SCL are sampled low at the beginning of the Start condition (Figure 14-26).
- SCL is sampled low before SDA is asserted low (Figure 14-27).

During a Start condition, both the SDA and the SCL pins are monitored.

If the SDA pin is already low, or the SCL pin is already low, then all of the following occur:

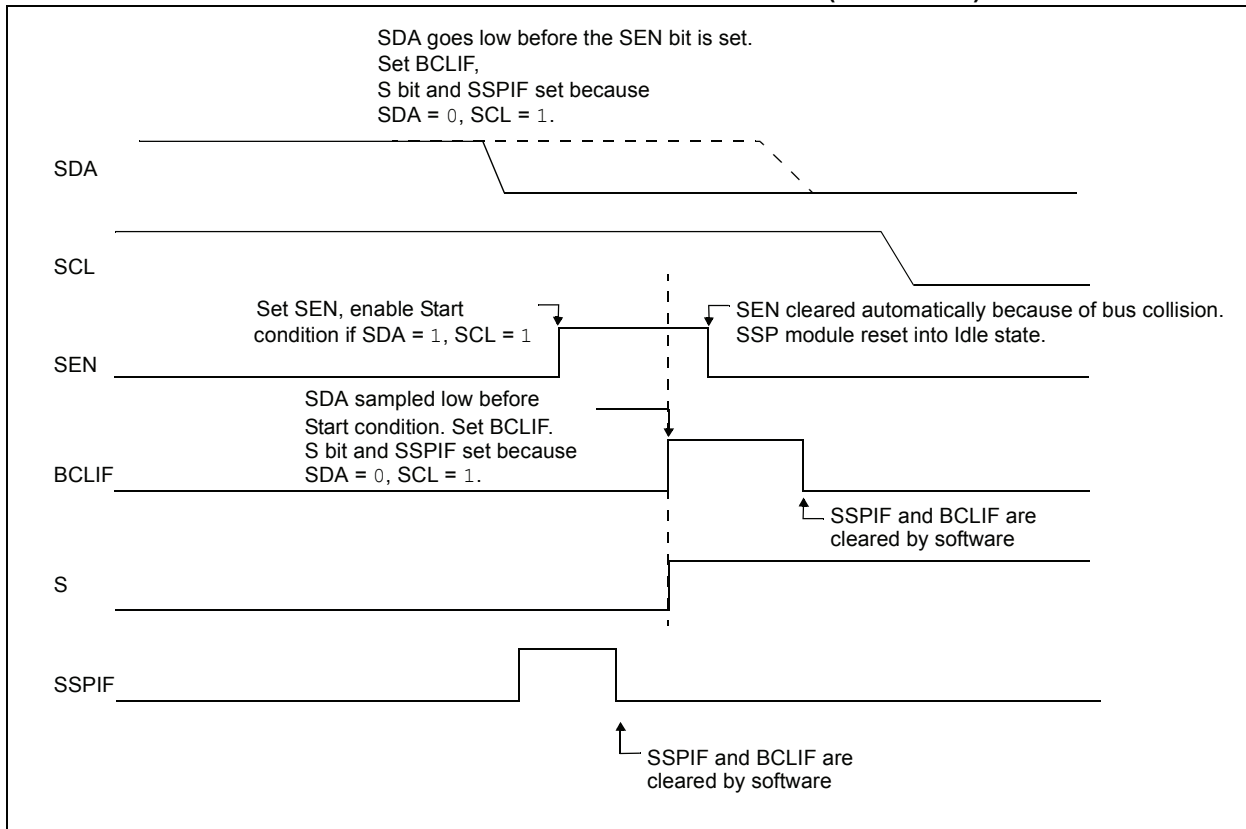
- the Start condition is aborted,
- the BCLIF flag is set and
- the MSSP module is reset to its Idle state (Figure 14-26).

The Start condition begins with the SDA and SCL pins deasserted. When the SDA pin is sampled high, the Baud Rate Generator is loaded and counts down. If the SCL pin is sampled low while SDA is high, a bus collision occurs because it is assumed that another master is attempting to drive a data '1' during the Start condition.

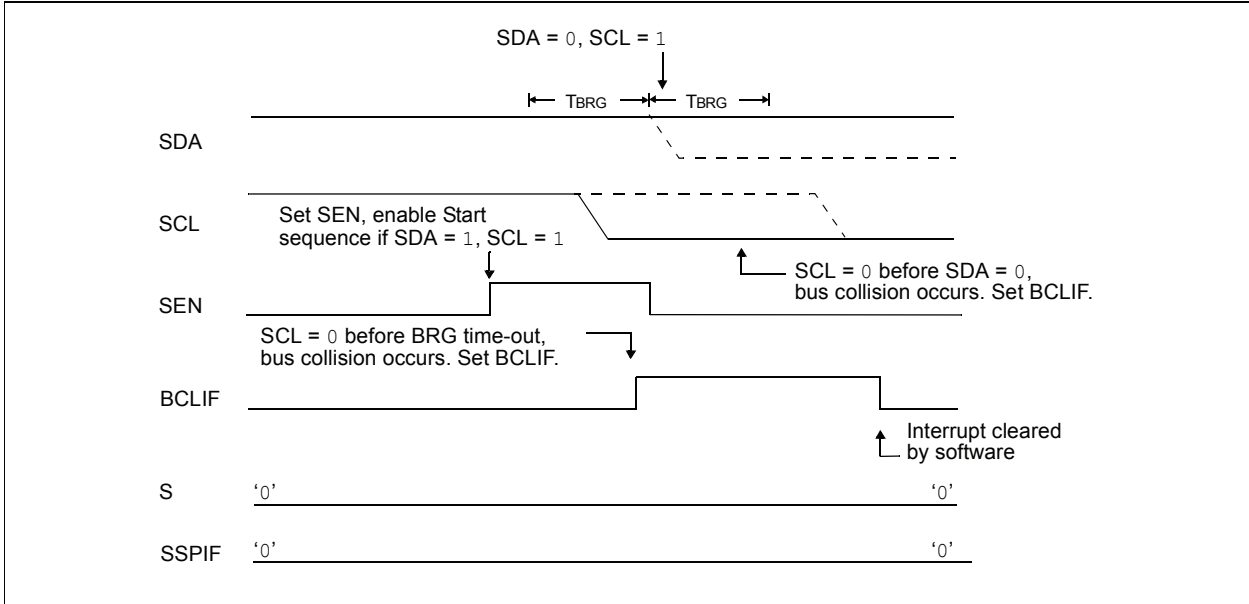
If the SDA pin is sampled low during this count, the BRG is reset and the SDA line is asserted early (Figure 14-28). If, however, a '1' is sampled on the SDA pin, the SDA pin is asserted low at the end of the BRG count. The Baud Rate Generator is then reloaded and counts down to 0; if the SCL pin is sampled as '0' during this time, a bus collision does not occur. At the end of the BRG count, the SCL pin is asserted low.

**Note:** The reason that bus collision is not a factor during a Start condition is that no two bus masters can assert a Start condition at the exact same time. Therefore, one master will always assert SDA before the other. This condition does not cause a bus collision because the two masters must be allowed to arbitrate the first address following the Start condition. If the address is the same, arbitration must be allowed to continue into the data portion, Repeated Start or Stop conditions.

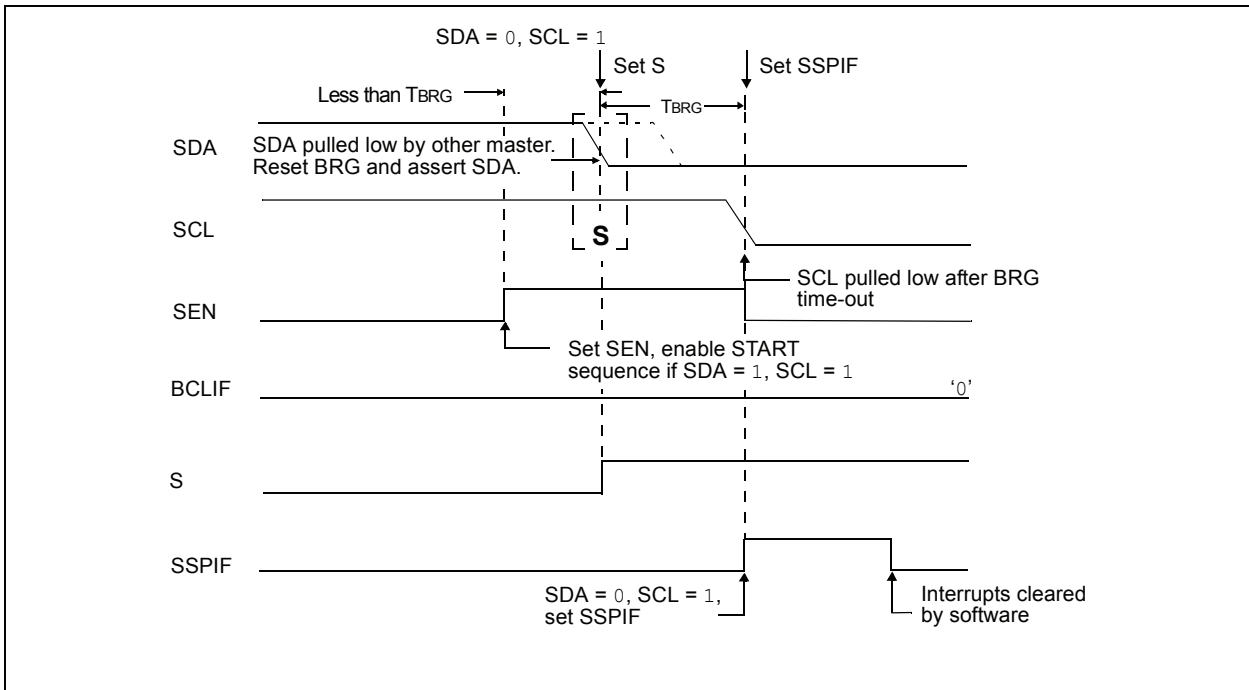
**FIGURE 14-26: BUS COLLISION DURING START CONDITION (SDA ONLY)**



**FIGURE 14-27: BUS COLLISION DURING START CONDITION (SCL = 0)**



**FIGURE 14-28: BRG RESET DUE TO SDA ARBITRATION DURING START CONDITION**



# PIC18(L)F1XK22

## 14.3.17.2 Bus Collision During a Repeated Start Condition

During a Repeated Start condition, a bus collision occurs if:

- A low level is sampled on SDA when SCL goes from low level to high level.
- SCL goes low before SDA is asserted low, indicating that another master is attempting to transmit a data '1'.

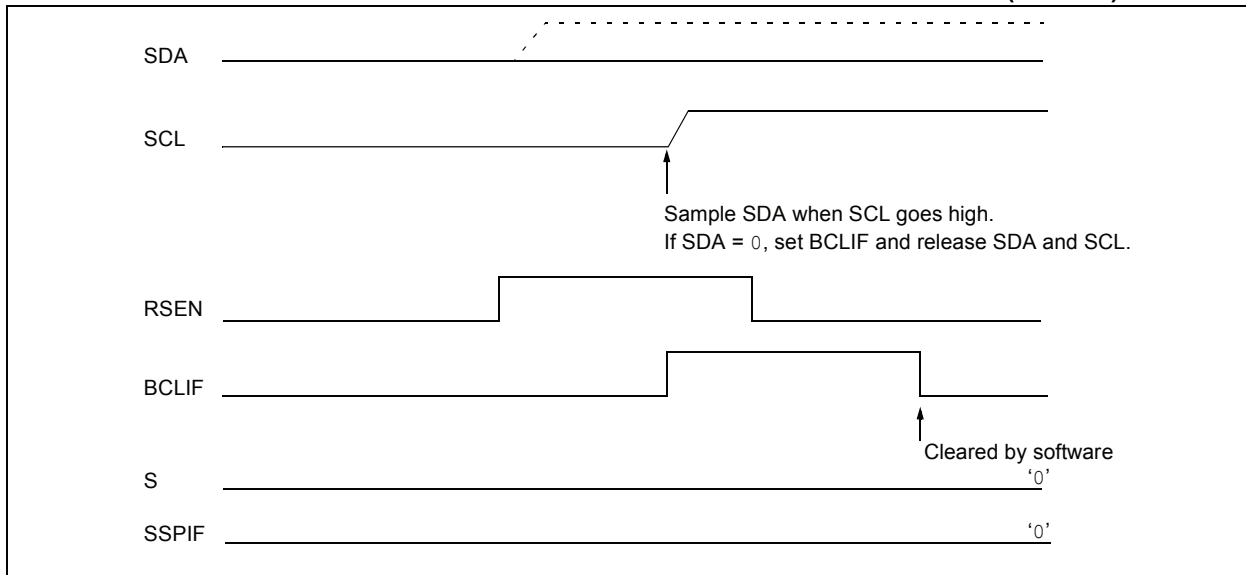
When the user deasserts SDA and the pin is allowed to float high, the BRG is loaded with SSPADD and counts down to 0. The SCL pin is then deasserted and when sampled high, the SDA pin is sampled.

If SDA is low, a bus collision has occurred (i.e., another master is attempting to transmit a data '0', [Figure 14-29](#)). If SDA is sampled high, the BRG is reloaded and begins counting. If SDA goes from high-to-low before the BRG times out, no bus collision occurs because no two masters can assert SDA at exactly the same time.

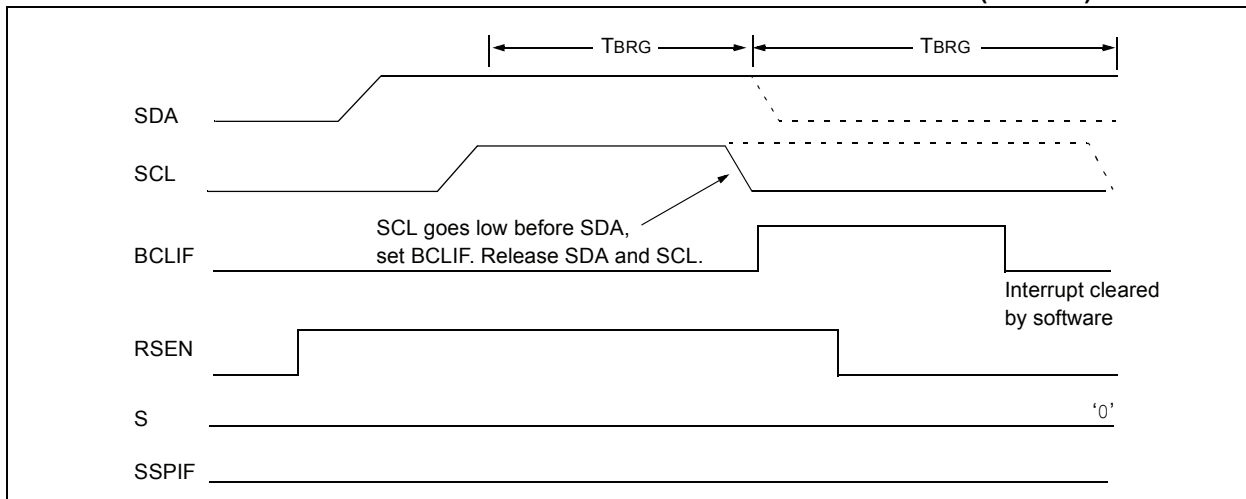
If SCL goes from high-to-low before the BRG times out and SDA has not already been asserted, a bus collision occurs. In this case, another master is attempting to transmit a data '1' during the Repeated Start condition, see [Figure 14-30](#).

If, at the end of the BRG time-out, both SCL and SDA are still high, the SDA pin is driven low and the BRG is reloaded and begins counting. At the end of the count, regardless of the status of the SCL pin, the SCL pin is driven low and the Repeated Start condition is complete.

**FIGURE 14-29: BUS COLLISION DURING A REPEATED START CONDITION (CASE 1)**



**FIGURE 14-30: BUS COLLISION DURING REPEATED START CONDITION (CASE 2)**



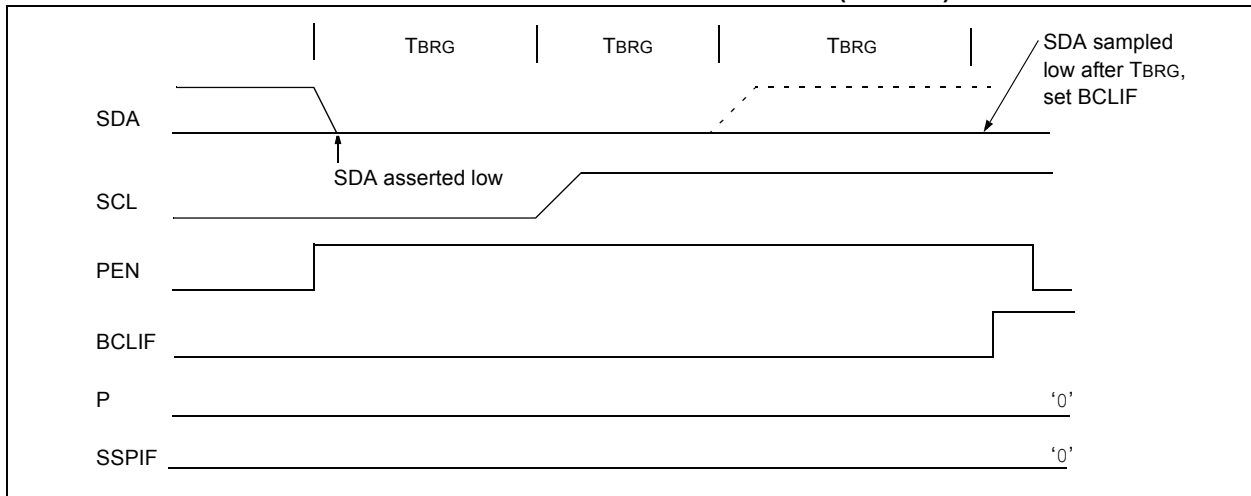
## 14.3.17.3 Bus Collision During a Stop Condition

Bus collision occurs during a Stop condition if:

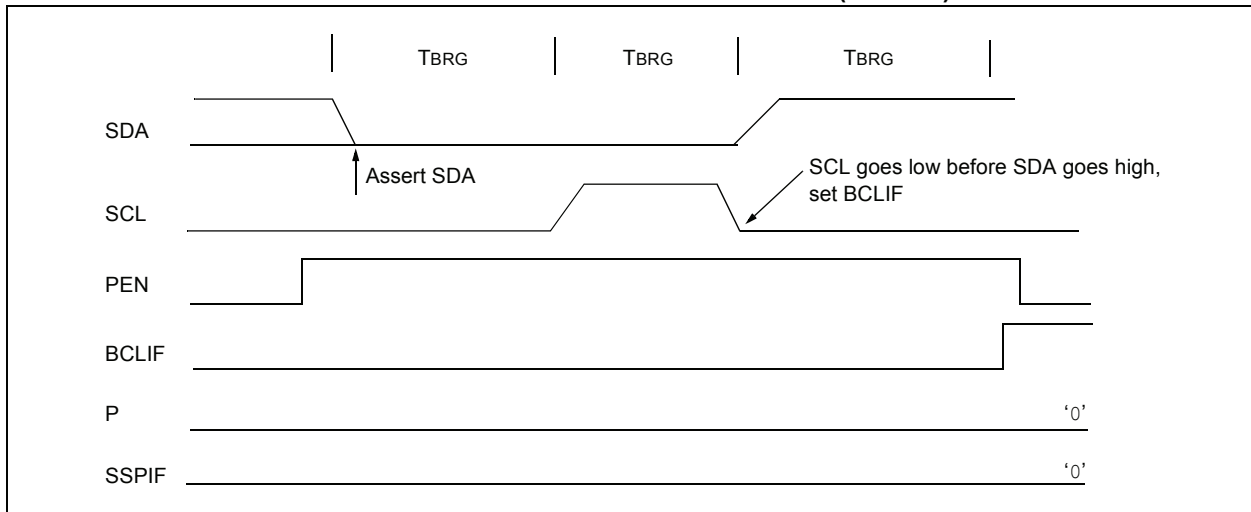
- After the SDA pin has been deasserted and allowed to float high, SDA is sampled low after the BRG has timed out.
- After the SCL pin is deasserted, SCL is sampled low before SDA goes high.

The Stop condition begins with SDA asserted low. When SDA is sampled low, the SCL pin is allowed to float. When the pin is sampled high (clock arbitration), the Baud Rate Generator is loaded with SSPADD and counts down to 0. After the BRG times out, SDA is sampled. If SDA is sampled low, a bus collision has occurred. This is due to another master attempting to drive a data '0' (Figure 14-31). If the SCL pin is sampled low before SDA is allowed to float high, a bus collision occurs. This is another case of another master attempting to drive a data '0' (Figure 14-32).

**FIGURE 14-31: BUS COLLISION DURING A STOP CONDITION (CASE 1)**



**FIGURE 14-32: BUS COLLISION DURING A STOP CONDITION (CASE 2)**



# PIC18(L)F1XK22

**TABLE 14-4: SUMMARY OF REGISTERS ASSOCIATED WITH I<sup>2</sup>C™**

Name	Bit 7	Bit 6	Bit 5	Bit 4	Bit 3	Bit 2	Bit 1	Bit 0	Reset Values on page
IPR1	—	ADIP	RCIP	TXIP	SSPIP	CCP1IP	TMR2IP	TMR1IP	256
IPR2	OSCFIP	C1IP	C2IP	EEIP	BCLIP	—	TMR3IP	—	256
PIE1	—	ADIE	RCIE	TXIE	SSPIE	CCP1IE	TMR2IE	TMR1IE	256
PIE2	OSCFIE	C1IE	C2IE	EEIE	BCLIE	—	TMR3IE	—	256
PIR1	—	ADIF	RCIF	TXIF	SSPIF	CCP1IF	TMR2IF	TMR1IF	256
PIR2	OSCFIF	C1IF	C2IF	EEIF	BCLIF	—	TMR3IF	—	256
SSPADD	SSP Address Register in I <sup>2</sup> C™ Slave Mode. SSP Baud Rate Reload Register in I <sup>2</sup> C Master Mode.								254
SSPBUF	SSP Receive Buffer/Transmit Register								254
SSPCON1	WCOL	SSPOV	SSPEN	CKP	SSPM3	SSPM2	SSPM1	SSPM0	254
SSPCON2	GCEN	ACKSTAT	ACKDT	ACKEN	RCEN	PEN	RSEN	SEN	254
SSPMSK	MSK7	MSK6	MSK5	MSK4	MSK3	MSK2	MSK1	MSK0	256
SSPSTAT	SMP	CKE	D/Ā	P	S	R/W	UA	BF	254
TRISB	TRISB7	TRISB6	TRISB5	TRISB4	—	—	—	—	256

**Legend:** — = unimplemented, read as '0'. Shaded cells are not used by I<sup>2</sup>C™.

## 15.0 ENHANCED UNIVERSAL SYNCHRONOUS ASYNCHRONOUS RECEIVER TRANSMITTER (EUSART)

The Enhanced Universal Synchronous Asynchronous Receiver Transmitter (EUSART) module is a serial I/O communications peripheral. It contains all the clock generators, shift registers and data buffers necessary to perform an input or output serial data transfer independent of device program execution. The EUSART, also known as a Serial Communications Interface (SCI), can be configured as a full-duplex asynchronous system or half-duplex synchronous system. Full-Duplex mode is useful for communications with peripheral systems, such as CRT terminals and personal computers. Half-Duplex Synchronous mode is intended for communications with peripheral devices, such as A/D or D/A integrated circuits, serial EEPROMs or other microcontrollers. These devices typically do not have internal clocks for baud rate generation and require the external clock signal provided by a master synchronous device.

The EUSART module includes the following capabilities:

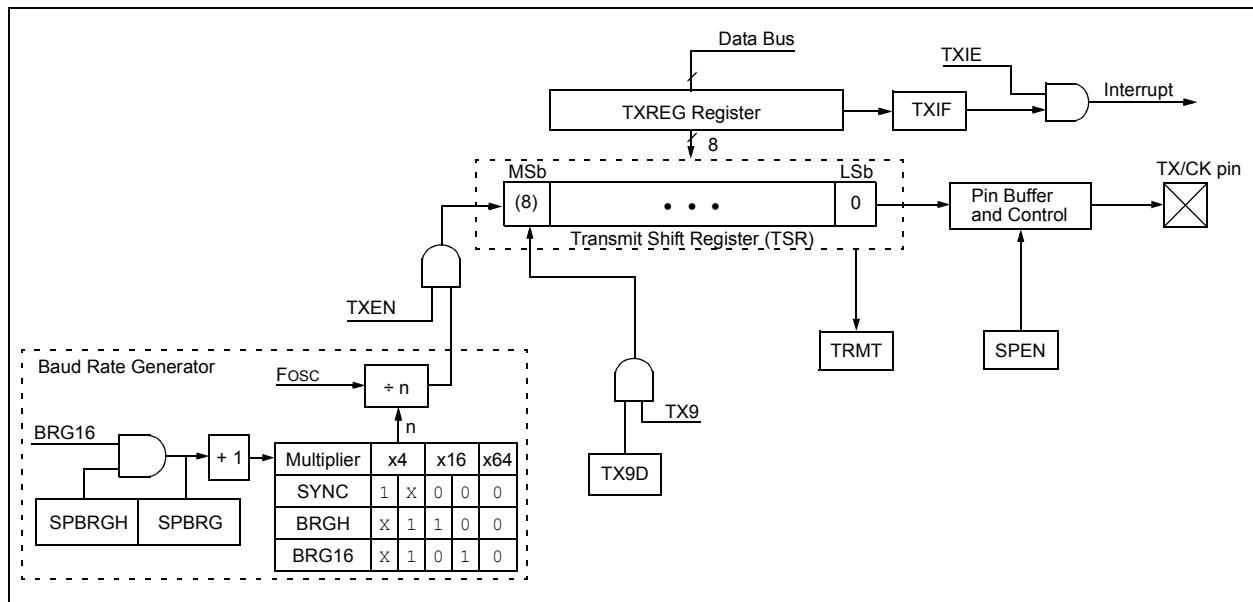
- Full-duplex asynchronous transmit and receive
- Two-character input buffer
- One-character output buffer
- Programmable 8-bit or 9-bit character length
- Address detection in 9-bit mode
- Input buffer overrun error detection
- Received character framing error detection
- Half-duplex synchronous master
- Half-duplex synchronous slave
- Programmable clock and data polarity

The EUSART module implements the following additional features, making it ideally suited for use in Local Interconnect Network (LIN) bus systems:

- Automatic detection and calibration of the baud rate
- Wake-up on Break reception
- 13-bit Break character transmit

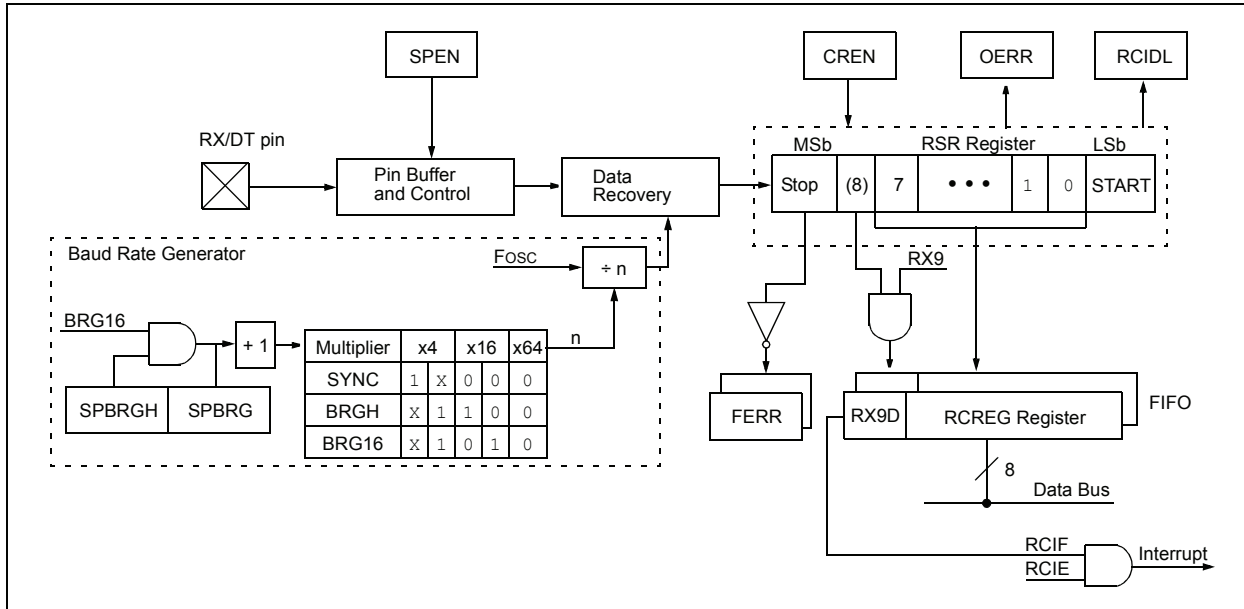
Block diagrams of the EUSART transmitter and receiver are shown in [Figure 15-1](#) and [Figure 15-2](#).

**FIGURE 15-1: EUSART TRANSMIT BLOCK DIAGRAM**



# PIC18(L)F1XK22

**FIGURE 15-2: EUSART RECEIVE BLOCK DIAGRAM**



The operation of the EUSART module is controlled through three registers:

- Transmit Status and Control (TXSTA)
- Receive Status and Control (RCSTA)
- Baud Rate Control (BAUDCTL)

These registers are detailed in [Register 15-1](#), [Register 15-2](#) and [Register 15-3](#), respectively.

For all modes of EUSART operation, the TRIS control bits corresponding to the RX/DT and TX/CK pins should be set to '1'. The EUSART control will automatically reconfigure the pin from input to output, as needed.



## 15.1 EUSART Asynchronous Mode

The EUSART transmits and receives data using the standard non-return-to-zero (NRZ) format. NRZ is implemented with two levels: a  $V_{OH}$  mark state which represents a '1' data bit, and a  $V_{OL}$  space state which represents a '0' data bit. NRZ refers to the fact that consecutively transmitted data bits of the same value stay at the output level of that bit without returning to a neutral level between each bit transmission. An NRZ transmission port idles in the mark state. Each character transmission consists of one Start bit followed by eight or nine data bits and is always terminated by one or more Stop bits. The Start bit is always a space and the Stop bits are always marks. The most common data format is 8 bits. Each transmitted bit persists for a period of  $1/(\text{Baud Rate})$ . An on-chip dedicated 8-bit/16-bit Baud Rate Generator is used to derive standard baud rate frequencies from the system oscillator. See [Table 15-5](#) for examples of baud rate configurations.

The EUSART transmits and receives the LSb first. The EUSART's transmitter and receiver are functionally independent, but share the same data format and baud rate. Parity is not supported by the hardware, but can be implemented in software and stored as the ninth data bit.

### 15.1.1 EUSART ASYNCHRONOUS TRANSMITTER

The EUSART transmitter block diagram is shown in [Figure 15-1](#). The heart of the transmitter is the serial Transmit Shift Register (TSR), which is not directly accessible by software. The TSR obtains its data from the transmit buffer, which is the TXREG register.

#### 15.1.1.1 Enabling the Transmitter

The EUSART transmitter is enabled for asynchronous operations by configuring the following three control bits:

- TXEN = 1
- SYNC = 0
- SPEN = 1

All other EUSART control bits are assumed to be in their default state.

Setting the TXEN bit of the TXSTA register enables the transmitter circuitry of the EUSART. Clearing the SYNC bit of the TXSTA register configures the EUSART for asynchronous operation. Setting the SPEN bit of the RCSTA register enables the EUSART and automatically configures the TX/CK I/O pin as an output. If the TX/CK pin is shared with an analog peripheral the analog I/O function must be disabled by clearing the corresponding ANSEL bit.

- Note 1:** When the SPEN bit is set the RX/DT I/O pin is automatically configured as an input, regardless of the state of the corresponding TRIS bit and whether or not the EUSART receiver is enabled. The RX/DT pin data can be read via a normal PORT read but PORT latch data output is precluded.
- 2:** The TXIF transmitter interrupt flag is set when the TXEN enable bit is set.

#### 15.1.1.2 Transmitting Data

A transmission is initiated by writing a character to the TXREG register. If this is the first character, or the previous character has been completely flushed from the TSR, the data in the TXREG is immediately transferred to the TSR register. If the TSR still contains all or part of a previous character, the new character data is held in the TXREG until the Stop bit of the previous character has been transmitted. The pending character in the TXREG is then transferred to the TSR in one  $T_{cy}$  immediately following the Stop bit transmission. The transmission of the Start bit, data bits and Stop bit sequence commences immediately following the transfer of the data to the TSR from the TXREG.

#### 15.1.1.3 Transmit Data Polarity

The polarity of the transmit data can be controlled with the CKTXP bit of the BAUDCON register. The default state of this bit is '0' which selects high true transmit idle and data bits. Setting the CKTXP bit to '1' will invert the transmit data resulting in low true idle and data bits. The CKTXP bit controls transmit data polarity only in Asynchronous mode. In Synchronous mode the CKTXP bit has a different function.

#### 15.1.1.4 Transmit Interrupt Flag

The TXIF interrupt flag bit of the PIR1 register is set whenever the EUSART transmitter is enabled and no character is being held for transmission in the TXREG. In other words, the TXIF bit is only clear when the TSR is busy with a character and a new character has been queued for transmission in the TXREG. The TXIF flag bit is not cleared immediately upon writing TXREG. TXIF becomes valid in the second instruction cycle following the write execution. Polling TXIF immediately following the TXREG write will return invalid results. The TXIF bit is read-only, it cannot be set or cleared by software.

The TXIF interrupt can be enabled by setting the TXIE interrupt enable bit of the PIE1 register. However, the TXIF flag bit will be set whenever the TXREG is empty, regardless of the state of TXIE enable bit.

# PIC18(L)F1XK22

To use interrupts when transmitting data, set the TXIE bit only when there is more data to send. Clear the TXIE interrupt enable bit upon writing the last character of the transmission to the TXREG.

## 15.1.1.5 TSR Status

The TRMT bit of the TXSTA register indicates the status of the TSR register. This is a read-only bit. The TRMT bit is set when the TSR register is empty and is cleared when a character is transferred to the TSR register from the TXREG. The TRMT bit remains clear until all bits have been shifted out of the TSR register. No interrupt logic is tied to this bit, so the user needs to poll this bit to determine the TSR status.

**Note:** The TSR register is not mapped in data memory, so it is not available to the user.

## 15.1.1.6 Transmitting 9-Bit Characters

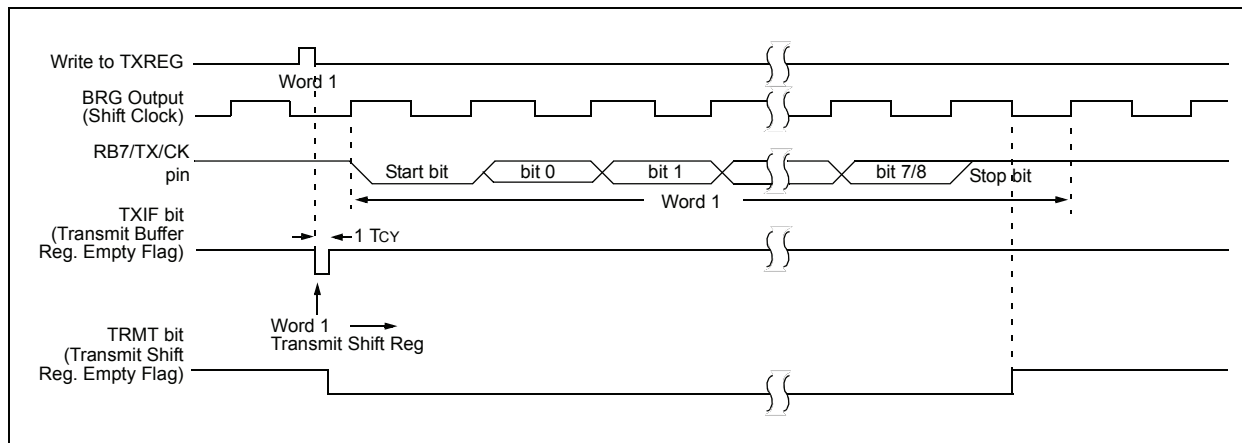
The EUSART supports 9-bit character transmissions. When the TX9 bit of the TXSTA register is set, the EUSART will shift 9 bits out for each character transmitted. The TX9D bit of the TXSTA register is the ninth, and Most Significant, data bit. When transmitting 9-bit data, the TX9D data bit must be written before writing the 8 Least Significant bits into the TXREG. All nine bits of data will be transferred to the TSR shift register immediately after the TXREG is written.

A special 9-bit Address mode is available for use with multiple receivers. See [Section 15.1.2.8 “Address Detection”](#) for more information on the Address mode.

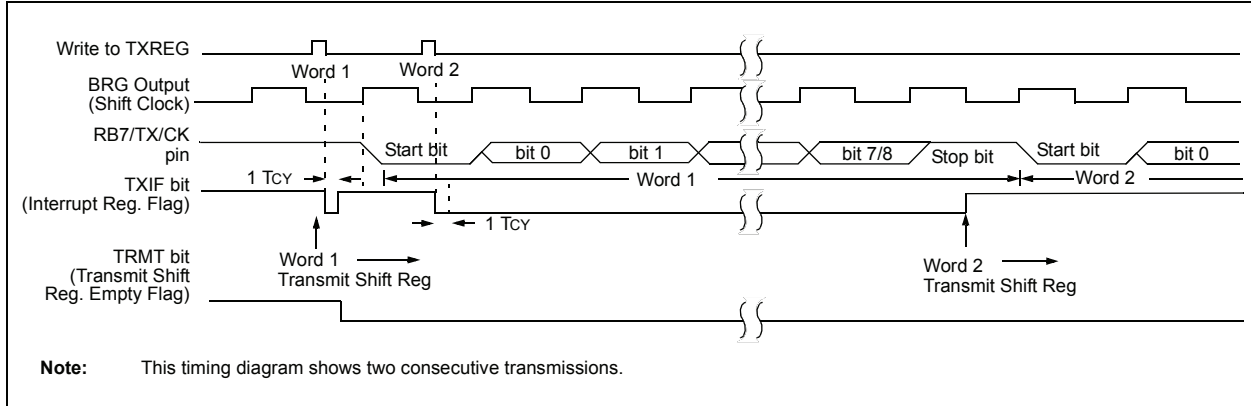
## 15.1.1.7 Asynchronous Transmission Set-up:

1. Initialize the SPBRGH:SPBRG register pair and the BRGH and BRG16 bits to achieve the desired baud rate (see [Section 15.3 “EUSART Baud Rate Generator \(BRG\)”](#)).
2. Enable the asynchronous serial port by clearing the SYNC bit and setting the SPEN bit.
3. If 9-bit transmission is desired, set the TX9 control bit. A set ninth data bit will indicate that the 8 Least Significant data bits are an address when the receiver is set for address detection.
4. Set the CKTXP control bit if inverted transmit data polarity is desired.
5. Enable the transmission by setting the TXEN control bit. This will cause the TXIF interrupt bit to be set.
6. If interrupts are desired, set the TXIE interrupt enable bit. An interrupt will occur immediately provided that the GIE and PEIE bits of the INTCON register are also set.
7. If 9-bit transmission is selected, the ninth bit should be loaded into the TX9D data bit.
8. Load 8-bit data into the TXREG register. This will start the transmission.

**FIGURE 15-3: ASYNCHRONOUS TRANSMISSION**



**FIGURE 15-4: ASYNCHRONOUS TRANSMISSION (BACK-TO-BACK)**



**TABLE 15-1: REGISTERS ASSOCIATED WITH ASYNCHRONOUS TRANSMISSION**

Name	Bit 7	Bit 6	Bit 5	Bit 4	Bit 3	Bit 2	Bit 1	Bit 0	Reset Values on page
BAUDCON	ABDOVF	RCIDL	DTRXP	CKTXP	BRG16	—	WUE	ABDEN	255
INTCON	GIE/GIEH	PEIE/GIEL	TMR0IE	INT0IE	RABIE	TMR0IF	INT0IF	RABIF	253
IPR1	—	ADIP	RCIP	TXIP	SSPIP	CCP1IP	TMR2IP	TMR1IP	256
PIE1	—	ADIE	RCIE	TXIE	SSPIE	CCP1IE	TMR2IE	TMR1IE	256
PIR1	—	ADIF	RCIF	TXIF	SSPIF	CCP1IF	TMR2IF	TMR1IF	256
RCSTA	SPEN	RX9	SREN	CREN	ADDEN	FERR	OERR	RX9D	255
SPBRG	EUSART Baud Rate Generator Register, Low Byte								255
SPBRGH	EUSART Baud Rate Generator Register, High Byte								255
TXREG	EUSART Transmit Register								255
TXSTA	CSRC	TX9	TXEN	SYNC	SENDB	BRGH	TRMT	TX9D	255

**Legend:** — = unimplemented locations read as '0'. Shaded cells are not used for asynchronous transmission.

# PIC18(L)F1XK22

## 15.1.2 EUSART ASYNCHRONOUS RECEIVER

The Asynchronous mode would typically be used in RS-232 systems. The receiver block diagram is shown in [Figure 15-2](#). The data is received on the RX/DT pin and drives the data recovery block. The data recovery block is actually a high-speed shifter operating at 16 times the baud rate, whereas the serial Receive Shift Register (RSR) operates at the bit rate. When all 8 or 9 bits of the character have been shifted in, they are immediately transferred to a two character First-In-First-Out (FIFO) memory. The FIFO buffering allows reception of two complete characters and the start of a third character before software must start servicing the EUSART receiver. The FIFO and RSR registers are not directly accessible by software. Access to the received data is via the RCREG register.

### 15.1.2.1 Enabling the Receiver

The EUSART receiver is enabled for asynchronous operation by configuring the following three control bits:

- CREN = 1
- SYNC = 0
- SPEN = 1

All other EUSART control bits are assumed to be in their default state.

Setting the CREN bit of the RCSTA register enables the receiver circuitry of the EUSART. Clearing the SYNC bit of the TXSTA register configures the EUSART for asynchronous operation. Setting the SPEN bit of the RCSTA register enables the EUSART. The RX/DT I/O pin must be configured as an input by setting the corresponding TRIS control bit. If the RX/DT pin is shared with an analog peripheral the analog I/O function must be disabled by clearing the corresponding ANSEL bit.

**Note:** When the SPEN bit is set the TX/CK I/O pin is automatically configured as an output, regardless of the state of the corresponding TRIS bit and whether or not the EUSART transmitter is enabled. The PORT latch is disconnected from the output driver so it is not possible to use the TX/CK pin as a general purpose output.

### 15.1.2.2 Receiving Data

The receiver data recovery circuit initiates character reception on the falling edge of the first bit. The first bit, also known as the Start bit, is always a zero. The data recovery circuit counts one-half bit time to the center of the Start bit and verifies that the bit is still a zero. If it is not a zero then the data recovery circuit aborts character reception, without generating an error, and resumes looking for the falling edge of the Start bit. If the Start bit zero verification succeeds then the data recovery circuit counts a full bit time to the center of the next bit. The bit is then sampled by a majority detect circuit and the resulting '0' or '1' is shifted into the RSR. This repeats until all data bits have been sampled and shifted into the RSR. One final bit time is measured and the level sampled. This is the Stop bit, which is always a '1'. If the data recovery circuit samples a '0' in the Stop bit position then a framing error is set for this character, otherwise the framing error is cleared for this character. See [Section 15.1.2.5 "Receive Framing Error"](#) for more information on framing errors.

Immediately after all data bits and the Stop bit have been received, the character in the RSR is transferred to the EUSART receive FIFO and the RCIF interrupt flag bit of the PIR1 register is set. The top character in the FIFO is transferred out of the FIFO by reading the RCREG register.

**Note:** If the receive FIFO is overrun, no additional characters will be received until the overrun condition is cleared. See [Section 15.1.2.6 "Receive Overrun Error"](#) for more information on overrun errors.

### 15.1.2.3 Receive Data Polarity

The polarity of the receive data can be controlled with the DTRXP bit of the BAUDCON register. The default state of this bit is '0' which selects high true receive idle and data bits. Setting the DTRXP bit to '1' will invert the receive data resulting in low true idle and data bits. The DTRXP bit controls receive data polarity only in Asynchronous mode. In Synchronous mode the DTRXP bit has a different function.

## 15.1.2.4 Receive Interrupts

The RCIF interrupt flag bit of the PIR1 register is set whenever the EUSART receiver is enabled and there is an unread character in the receive FIFO. The RCIF interrupt flag bit is read-only, it cannot be set or cleared by software.

RCIF interrupts are enabled by setting the following bits:

- RCIE interrupt enable bit of the PIE1 register
- PEIE peripheral interrupt enable bit of the INTCON register
- GIE global interrupt enable bit of the INTCON register

The RCIF interrupt flag bit will be set when there is an unread character in the FIFO, regardless of the state of interrupt enable bits.

## 15.1.2.5 Receive Framing Error

Each character in the receive FIFO buffer has a corresponding framing error Status bit. A framing error indicates that a Stop bit was not seen at the expected time. The framing error status is accessed via the FERR bit of the RCSTA register. The FERR bit represents the status of the top unread character in the receive FIFO. Therefore, the FERR bit must be read before reading the RCREG.

The FERR bit is read-only and only applies to the top unread character in the receive FIFO. A framing error (FERR = 1) does not preclude reception of additional characters. It is not necessary to clear the FERR bit. Reading the next character from the FIFO buffer will advance the FIFO to the next character and the next corresponding framing error.

The FERR bit can be forced clear by clearing the SPEN bit of the RCSTA register which resets the EUSART. Clearing the CREN bit of the RCSTA register does not affect the FERR bit. A framing error by itself does not generate an interrupt.

<b>Note:</b> If all receive characters in the receive FIFO have framing errors, repeated reads of the RCREG will not clear the FERR bit.
--

## 15.1.2.6 Receive Overrun Error

The receive FIFO buffer can hold two characters. An overrun error will be generated if a third character, in its entirety, is received before the FIFO is accessed. When this happens the OERR bit of the RCSTA register is set. The characters already in the FIFO buffer can be read but no additional characters will be received until the error is cleared. The error must be cleared by either clearing the CREN bit of the RCSTA register or by resetting the EUSART by clearing the SPEN bit of the RCSTA register.

## 15.1.2.7 Receiving 9-bit Characters

The EUSART supports 9-bit character reception. When the RX9 bit of the RCSTA register is set, the EUSART will shift 9 bits into the RSR for each character received. The RX9D bit of the RCSTA register is the ninth and Most Significant data bit of the top unread character in the receive FIFO. When reading 9-bit data from the receive FIFO buffer, the RX9D data bit must be read before reading the 8 Least Significant bits from the RCREG.

## 15.1.2.8 Address Detection

A special Address Detection mode is available for use when multiple receivers share the same transmission line, such as in RS-485 systems. Address detection is enabled by setting the ADDEN bit of the RCSTA register.

Address detection requires 9-bit character reception. When address detection is enabled, only characters with the ninth data bit set will be transferred to the receive FIFO buffer, thereby setting the RCIF interrupt bit. All other characters will be ignored.

Upon receiving an address character, user software determines if the address matches its own. Upon address match, user software must disable address detection by clearing the ADDEN bit before the next Stop bit occurs. When user software detects the end of the message, determined by the message protocol used, software places the receiver back into the Address Detection mode by setting the ADDEN bit.

# PIC18(L)F1XK22

## 15.1.2.9 Asynchronous Reception Set-up:

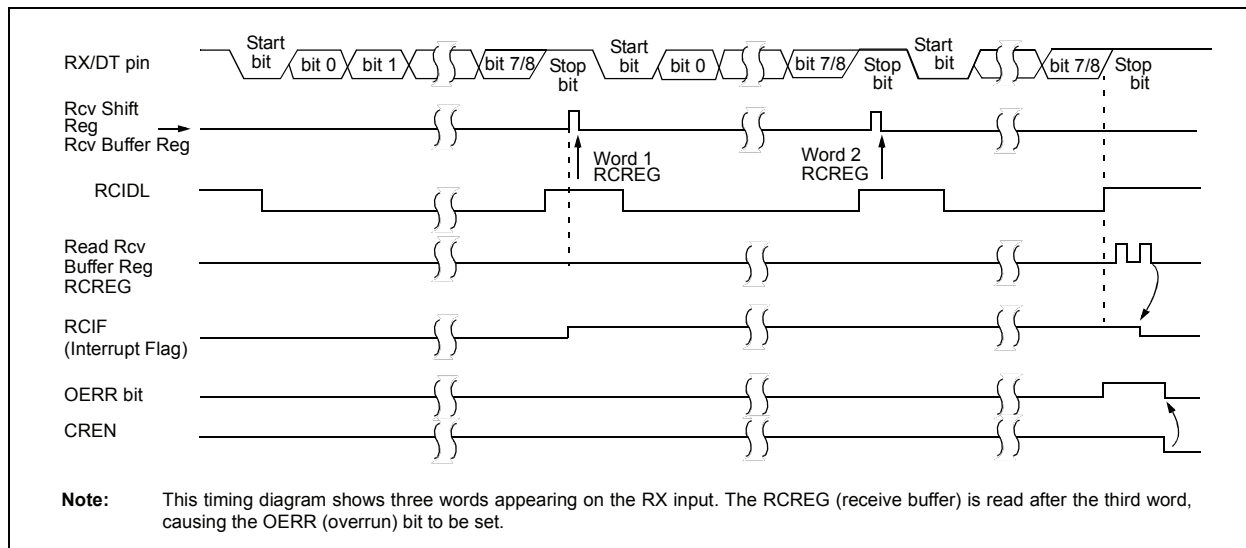
1. Initialize the SPBRGH:SPBRG register pair and the BRGH and BRG16 bits to achieve the desired baud rate (see [Section 15.3 “EUSART Baud Rate Generator \(BRG\)”](#)).
2. Enable the serial port by setting the SPEN bit and the RX/DT pin TRIS bit. The SYNC bit must be clear for asynchronous operation.
3. If interrupts are desired, set the RCIE interrupt enable bit and set the GIE and PEIE bits of the INTCON register.
4. If 9-bit reception is desired, set the RX9 bit.
5. Set the DTRXP if inverted receive polarity is desired.
6. Enable reception by setting the CREN bit.
7. The RCIF interrupt flag bit will be set when a character is transferred from the RSR to the receive buffer. An interrupt will be generated if the RCIE interrupt enable bit was also set.
8. Read the RCSTA register to get the error flags and, if 9-bit data reception is enabled, the ninth data bit.
9. Get the received 8 Least Significant data bits from the receive buffer by reading the RCREG register.
10. If an overrun occurred, clear the OERR flag by clearing the CREN receiver enable bit.

## 15.1.2.10 9-bit Address Detection Mode Set-up

This mode would typically be used in RS-485 systems. To set up an Asynchronous Reception with Address Detect Enable:

1. Initialize the SPBRGH, SPBRG register pair and the BRGH and BRG16 bits to achieve the desired baud rate (see [Section 15.3 “EUSART Baud Rate Generator \(BRG\)”](#)).
2. Enable the serial port by setting the SPEN bit. The SYNC bit must be clear for asynchronous operation.
3. If interrupts are desired, set the RCIE interrupt enable bit and set the GIE and PEIE bits of the INTCON register.
4. Enable 9-bit reception by setting the RX9 bit.
5. Enable address detection by setting the ADDEN bit.
6. Set the DTRXP if inverted receive polarity is desired.
7. Enable reception by setting the CREN bit.
8. The RCIF interrupt flag bit will be set when a character with the ninth bit set is transferred from the RSR to the receive buffer. An interrupt will be generated if the RCIE interrupt enable bit was also set.
9. Read the RCSTA register to get the error flags. The ninth data bit will always be set.
10. Get the received 8 Least Significant data bits from the receive buffer by reading the RCREG register. Software determines if this is the device's address.
11. If an overrun occurred, clear the OERR flag by clearing the CREN receiver enable bit.
12. If the device has been addressed, clear the ADDEN bit to allow all received data into the receive buffer and generate interrupts.

**FIGURE 15-5: ASYNCHRONOUS RECEPTION**



**TABLE 15-2: REGISTERS ASSOCIATED WITH ASYNCHRONOUS RECEPTION**

Name	Bit 7	Bit 6	Bit 5	Bit 4	Bit 3	Bit 2	Bit 1	Bit 0	Reset Values on page
BAUDCON	ABDOVF	RCIDL	DTRXP	CKTXP	BRG16	—	WUE	ABDEN	255
INTCON	GIE/GIEH	PEIE/GIEL	TMR0IE	INT0IE	RABIE	TMR0IF	INT0IF	RABIF	253
IPR1	—	ADIP	RCIP	TXIP	SSPIP	CCP1IP	TMR2IP	TMR1IP	256
PIE1	—	ADIE	RCIE	TXIE	SSPIE	CCP1IE	TMR2IE	TMR1IE	256
PIR1	—	ADIF	RCIF	TXIF	SSPIF	CCP1IF	TMR2IF	TMR1IF	256
RCREG	EUSART Receive Register								255
RCSTA	SPEN	RX9	SREN	CREN	ADDEN	FERR	OERR	RX9D	255
SPBRG	EUSART Baud Rate Generator Register, Low Byte								255
SPBRGH	EUSART Baud Rate Generator Register, High Byte								255
TRISC	TRISC7	TRISC6	TRISC5	TRISC4	TRISC3	TRISC2	TRISC1	TRISC0	256
TXSTA	CSRC	TX9	TXEN	SYNC	SEnDB	BRGH	TRMT	TX9D	255

**Legend:** — = unimplemented locations read as '0'. Shaded cells are not used for asynchronous reception.

# PIC18(L)F1XK22

## 15.2 Clock Accuracy with Asynchronous Operation

The factory calibrates the internal oscillator block output (HFINTOSC). However, the HFINTOSC frequency may drift as V<sub>DD</sub> or temperature changes, and this directly affects the asynchronous baud rate. Two methods may be used to adjust the baud rate clock, but both require a reference clock source of some kind.

The first (preferred) method uses the OSCTUNE register to adjust the HFINTOSC output. Adjusting the value in the OSCTUNE register allows for fine resolution changes to the system clock source. See [Section 2.7.1 “OSCTUNE Register”](#) for more information.

The other method adjusts the value in the Baud Rate Generator. This can be done automatically with the Auto-Baud Detect feature (see [Section 15.3.1 “Auto-Baud Detect”](#)). There may not be fine enough resolution when adjusting the Baud Rate Generator to compensate for a gradual change in the peripheral clock frequency.

### REGISTER 15-1: TXSTA: TRANSMIT STATUS AND CONTROL REGISTER

R/W-0	R/W-0	R/W-0	R/W-0	R/W-0	R/W-0	R-1	R/W-0
CSRC	TX9	TXEN <sup>(1)</sup>	SYNC	SENDB	BRGH	TRMT	TX9D
bit 7							bit 0

#### Legend:

R = Readable bit

W = Writable bit

U = Unimplemented bit, read as '0'

-n = Value at POR

'1' = Bit is set

'0' = Bit is cleared

x = Bit is unknown

bit 7	<b>CSRC:</b> Clock Source Select bit <u>Asynchronous mode:</u> Don't care <u>Synchronous mode:</u> 1 = Master mode (clock generated internally from BRG) 0 = Slave mode (clock from external source)
bit 6	<b>TX9:</b> 9-bit Transmit Enable bit 1 = Selects 9-bit transmission 0 = Selects 8-bit transmission
bit 5	<b>TXEN:</b> Transmit Enable bit <sup>(1)</sup> 1 = Transmit enabled 0 = Transmit disabled
bit 4	<b>SYNC:</b> EUSART Mode Select bit 1 = Synchronous mode 0 = Asynchronous mode
bit 3	<b>SENDB:</b> Send Break Character bit <u>Asynchronous mode:</u> 1 = Send Sync Break on next transmission (cleared by hardware upon completion) 0 = Sync Break transmission completed <u>Synchronous mode:</u> Don't care
bit 2	<b>BRGH:</b> High Baud Rate Select bit <u>Asynchronous mode:</u> 1 = High speed 0 = Low speed <u>Synchronous mode:</u> Unused in this mode
bit 1	<b>TRMT:</b> Transmit Shift Register Status bit 1 = TSR empty 0 = TSR full
bit 0	<b>TX9D:</b> Ninth bit of Transmit Data Can be address/data bit or a parity bit.

**Note 1:** SREN/CREN overrides TXEN in Sync mode.



## REGISTER 15-2: RCSTA: RECEIVE STATUS AND CONTROL REGISTER<sup>(1)</sup>

R/W-0	R/W-0	R/W-0	R/W-0	R/W-0	R-0	R-0	R-x
SPEN	RX9	SREN	CREN	ADDEN	FERR	OERR	RX9D
bit 7							bit 0

### Legend:

R = Readable bit	W = Writable bit	U = Unimplemented bit, read as '0'
-n = Value at POR	'1' = Bit is set	'0' = Bit is cleared
		x = Bit is unknown

- bit 7      **SPEN:** Serial Port Enable bit  
 1 = Serial port enabled (configures RX/DT and TX/CK pins as serial port pins)  
 0 = Serial port disabled (held in Reset)
- bit 6      **RX9:** 9-bit Receive Enable bit  
 1 = Selects 9-bit reception  
 0 = Selects 8-bit reception
- bit 5      **SREN:** Single Receive Enable bit  
Asynchronous mode:  
 Don't care  
Synchronous mode – Master:  
 1 = Enables single receive  
 0 = Disables single receive  
 This bit is cleared after reception is complete.  
Synchronous mode – Slave  
 Don't care
- bit 4      **CREN:** Continuous Receive Enable bit  
Asynchronous mode:  
 1 = Enables receiver  
 0 = Disables receiver  
Synchronous mode:  
 1 = Enables continuous receive until enable bit CREN is cleared (CREN overrides SREN)  
 0 = Disables continuous receive
- bit 3      **ADDEN:** Address Detect Enable bit  
Asynchronous mode 9-bit (RX9 = 1):  
 1 = Enables address detection, enable interrupt and load the receive buffer when RSR<8> is set  
 0 = Disables address detection, all bytes are received and ninth bit can be used as parity bit  
Asynchronous mode 8-bit (RX9 = 0):  
 Don't care
- bit 2      **FERR:** Framing Error bit  
 1 = Framing error (can be updated by reading RCREG register and receive next valid byte)  
 0 = No framing error
- bit 1      **OERR:** Overrun Error bit  
 1 = Overrun error (can be cleared by clearing bit CREN)  
 0 = No overrun error
- bit 0      **RX9D:** Ninth bit of Received Data  
 This can be address/data bit or a parity bit and must be calculated by user firmware.

# PIC18(L)F1XK22

## REGISTER 15-3: BAUDCON: BAUD RATE CONTROL REGISTER

R-0	R-1	R/W-0	R/W-0	R/W-0	U-0	R/W-0	R/W-0
ABDOVF	RCIDL	DTRXP	CKTXP	BRG16	—	WUE	ABDEN
bit 7							bit 0

### Legend:

R = Readable bit	W = Writable bit	U = Unimplemented bit, read as '0'
-n = Value at POR	'1' = Bit is set	'0' = Bit is cleared
		x = Bit is unknown

- bit 7      **ABDOVF**: Auto-Baud Detect Overflow bit  
Asynchronous mode:  
 1 = Auto-baud timer overflowed  
 0 = Auto-baud timer did not overflow  
Synchronous mode:  
 Don't care
- bit 6      **RCIDL**: Receive Idle Flag bit  
Asynchronous mode:  
 1 = Receiver is Idle  
 0 = Start bit has been detected and the receiver is active  
Synchronous mode:  
 Don't care
- bit 5      **DTRXP**: Data/Receive Polarity Select bit  
Asynchronous mode:  
 1 = Receive data (RX) is inverted (active-low)  
 0 = Receive data (RX) is not inverted (active-high)  
Synchronous mode:  
 1 = Data (DT) is inverted (active-low)  
 0 = Data (DT) is not inverted (active-high)
- bit 4      **CKTXP**: Clock/Transmit Polarity Select bit  
Asynchronous mode:  
 1 = Idle state for transmit (TX) is low  
 0 = Idle state for transmit (TX) is high  
Synchronous mode:  
 1 = Data changes on the falling edge of the clock and is sampled on the rising edge of the clock  
 0 = Data changes on the rising edge of the clock and is sampled on the falling edge of the clock
- bit 3      **BRG16**: 16-bit Baud Rate Generator bit  
 1 = 16-bit Baud Rate Generator is used (SPBRGH:SPBRG)  
 0 = 8-bit Baud Rate Generator is used (SPBRG)
- bit 2      **Unimplemented**: Read as '0'
- bit 1      **WUE**: Wake-up Enable bit  
Asynchronous mode:  
 1 = Receiver is waiting for a falling edge. No character will be received but RCIF will be set on the falling edge. WUE will automatically clear on the rising edge.  
 0 = Receiver is operating normally  
Synchronous mode:  
 Don't care
- bit 0      **ABDEN**: Auto-Baud Detect Enable bit  
Asynchronous mode:  
 1 = Auto-Baud Detect mode is enabled (clears when auto-baud is complete)  
 0 = Auto-Baud Detect mode is disabled  
Synchronous mode:  
 Don't care

## 15.3 EUSART Baud Rate Generator (BRG)

The Baud Rate Generator (BRG) is an 8-bit or 16-bit timer that is dedicated to the support of both the asynchronous and synchronous EUSART operation. By default, the BRG operates in 8-bit mode. Setting the BRG16 bit of the BAUDCON register selects 16-bit mode.

The SPBRGH:SPBRG register pair determines the period of the free running baud rate timer. In Asynchronous mode the multiplier of the baud rate period is determined by both the BRGH bit of the TXSTA register and the BRG16 bit of the BAUDCON register. In Synchronous mode, the BRGH bit is ignored.

Table 15-3 contains the formulas for determining the baud rate. Example 15-1 provides a sample calculation for determining the baud rate and baud rate error.

Typical baud rates and error values for various asynchronous modes have been computed for your convenience and are shown in Table 15-5. It may be advantageous to use the high baud rate (BRGH = 1), or the 16-bit BRG (BRG16 = 1) to reduce the baud rate error. The 16-bit BRG mode is used to achieve slow baud rates for fast oscillator frequencies.

Writing a new value to the SPBRGH, SPBRG register pair causes the BRG timer to be reset (or cleared). This ensures that the BRG does not wait for a timer overflow before outputting the new baud rate.

If the system clock is changed during an active receive operation, a receive error or data loss may result. To avoid this problem, check the status of the RCIDL bit to make sure that the receive operation is Idle before changing the system clock.

### EXAMPLE 15-1: CALCULATING BAUD RATE ERROR

For a device with Fosc of 16 MHz, desired baud rate of 9600, Asynchronous mode, 8-bit BRG:

$$\text{Desired Baud Rate} = \frac{F_{OSC}}{64([SPBRGH:SPBRG] + 1)}$$

Solving for SPBRGH:SPBRG:

$$X = \left( \frac{F_{OSC}}{64 * (\text{Desired Baud Rate})} \right) - 1$$

$$= \left( \frac{16,000,000}{64 * 9600} \right) - 1$$

$$= [25.042] = 25$$

$$\text{Calculated Baud Rate} = \frac{16000000}{64(25 + 1)}$$

$$= 9615$$

$$\text{Error} = \frac{\text{Calc. Baud Rate} - \text{Desired Baud Rate}}{\text{Desired Baud Rate}}$$

$$= \frac{(9615 - 9600)}{9600} = 0.16\%$$

TABLE 15-3: BAUD RATE FORMULAS

Configuration Bits			BRG/EUSART Mode	Baud Rate Formula
SYNC	BRG16	BRGH		
0	0	0	8-bit/Asynchronous	Fosc/[64 (n+1)]
0	0	1	8-bit/Asynchronous	Fosc/[16 (n+1)]
0	1	0	16-bit/Asynchronous	
0	1	1	16-bit/Asynchronous	Fosc/[4 (n+1)]
1	0	x	8-bit/Synchronous	
1	1	x	16-bit/Synchronous	

Legend: x = Don't care, n = value of SPBRGH, SPBRG register pair

TABLE 15-4: REGISTERS ASSOCIATED WITH BAUD RATE GENERATOR

Name	Bit 7	Bit 6	Bit 5	Bit 4	Bit 3	Bit 2	Bit 1	Bit 0	Reset Values on page
BAUDCON	ABDOVF	RCIDL	DTRXP	CKTXP	BRG16	—	WUE	ABDEN	255
RCSTA	SPEN	RX9	SREN	CREN	ADDEN	FERR	OERR	RX9D	255
SPBRG	EUSART Baud Rate Generator Register, Low Byte								255
SPBRGH	EUSART Baud Rate Generator Register, High Byte								255
TXSTA	CSRC	TX9	TXEN	SYNC	SENDB	BRGH	TRMT	TX9D	255

Legend: — = unimplemented, read as '0'. Shaded cells are not used by the BRG.

# PIC18(L)F1XK22

**TABLE 15-5: BAUD RATES FOR ASYNCHRONOUS MODES**

BAUD RATE	SYNC = 0, BRGH = 0, BRG16 = 0											
	Fosc = 48.000 MHz			Fosc = 18.432 MHz			Fosc = 12.000 MHz			Fosc = 11.0592 MHz		
	Actual Rate	% Error	SPBRG value (decimal)	Actual Rate	% Error	SPBRG value (decimal)	Actual Rate	% Error	SPBRG value (decimal)	Actual Rate	% Error	SPBRG value (decimal)
300	—	—	—	—	—	—	—	—	—	—	—	—
1200	—	—	—	1200	0.00	239	1202	0.16	155	1200	0.00	143
2400	—	—	—	2400	0.00	119	2404	0.16	77	2400	0.00	71
9600	9615	0.16	77	9600	0.00	29	9375	-2.34	19	9600	0.00	17
10417	10417	0.00	71	10286	-1.26	27	10417	0.00	17	10165	-2.42	16
19.2k	19.23k	0.16	38	19.20k	0.00	14	18.75k	-2.34	9	19.20k	0.00	8
57.6k	57.69k	0.16	12	57.60k	0.00	7	—	—	—	57.60k	0.00	2
115.2k	—	—	—	—	—	—	—	—	—	—	—	—

BAUD RATE	SYNC = 0, BRGH = 0, BRG16 = 0											
	Fosc = 8.000 MHz			Fosc = 4.000 MHz			Fosc = 3.6864 MHz			Fosc = 1.000 MHz		
	Actual Rate	% Error	SPBRG value (decimal)	Actual Rate	% Error	SPBRG value (decimal)	Actual Rate	% Error	SPBRG value (decimal)	Actual Rate	% Error	SPBRG value (decimal)
300	—	—	—	300	0.16	207	300	0.00	191	300	0.16	51
1200	1202	0.16	103	1202	0.16	51	1200	0.00	47	1202	0.16	12
2400	2404	0.16	51	2404	0.16	25	2400	0.00	23	—	—	—
9600	9615	0.16	12	—	—	—	9600	0.00	5	—	—	—
10417	10417	0.00	11	10417	0.00	5	—	—	—	—	—	—
19.2k	—	—	—	—	—	—	19.20k	0.00	2	—	—	—
57.6k	—	—	—	—	—	—	57.60k	0.00	0	—	—	—
115.2k	—	—	—	—	—	—	—	—	—	—	—	—

BAUD RATE	SYNC = 0, BRGH = 1, BRG16 = 0											
	Fosc = 48.000 MHz			Fosc = 18.432 MHz			Fosc = 12.000 MHz			Fosc = 11.0592 MHz		
	Actual Rate	% Error	SPBRG value (decimal)	Actual Rate	% Error	SPBRG value (decimal)	Actual Rate	% Error	SPBRG value (decimal)	Actual Rate	% Error	SPBRG value (decimal)
300	—	—	—	—	—	—	—	—	—	—	—	—
1200	—	—	—	—	—	—	—	—	—	—	—	—
2400	—	—	—	—	—	—	—	—	—	—	—	—
9600	—	—	—	9600	0.00	119	9615	0.16	77	9600	0.00	71
10417	—	—	—	10378	-0.37	110	10417	0.00	71	10473	0.53	65
19.2k	19.23k	0.16	155	19.20k	0.00	59	19.23k	0.16	38	19.20k	0.00	35
57.6k	57.69k	0.16	51	57.60k	0.00	19	57.69k	0.16	12	57.60k	0.00	11
115.2k	115.38k	0.16	25	115.2k	0.00	9	—	—	—	115.2k	0.00	5

# PIC18(L)F1XK22

**TABLE 15-5: BAUD RATES FOR ASYNCHRONOUS MODES (CONTINUED)**

BAUD RATE	SYNC = 0, BRGH = 1, BRG16 = 0											
	Fosc = 8.000 MHz			Fosc = 4.000 MHz			Fosc = 3.6864 MHz			Fosc = 1.000 MHz		
	Actual Rate	% Error	SPBRG value (decimal)	Actual Rate	% Error	SPBRG value (decimal)	Actual Rate	% Error	SPBRG value (decimal)	Actual Rate	% Error	SPBRG value (decimal)
300	—	—	—	—	—	—	—	—	—	300	0.16	207
1200	—	—	—	1202	0.16	207	1200	0.00	191	1202	0.16	51
2400	2404	0.16	207	2404	0.16	103	2400	0.00	95	2404	0.16	25
9600	9615	0.16	51	9615	0.16	25	9600	0.00	23	—	—	—
10417	10417	0.00	47	10417	0.00	23	10473	0.53	21	10417	0.00	5
19.2k	19231	0.16	25	19.23k	0.16	12	19.2k	0.00	11	—	—	—
57.6k	55556	-3.55	8	—	—	—	57.60k	0.00	3	—	—	—
115.2k	—	—	—	—	—	—	115.2k	0.00	1	—	—	—

BAUD RATE	SYNC = 0, BRGH = 0, BRG16 = 1											
	Fosc = 48.000 MHz			Fosc = 18.432 MHz			Fosc = 12.000 MHz			Fosc = 11.0592 MHz		
	Actual Rate	% Error	SPBRGH :SPBRG (decimal)	Actual Rate	% Error	SPBRGH :SPBRG (decimal)	Actual Rate	% Error	SPBRGH :SPBRG (decimal)	Actual Rate	% Error	SPBRGH :SPBRG (decimal)
300	300.0	0.00	9999	300.0	0.00	3839	300	0.00	2499	300.0	0.00	2303
1200	1200.1	0.00	2499	1200	0.00	959	1200	0.00	624	1200	0.00	575
2400	2400	0.00	1249	2400	0.00	479	2404	0.16	311	2400	0.00	287
9600	9615	0.16	311	9600	0.00	119	9615	0.16	77	9600	0.00	71
10417	10417	0.00	287	10378	-0.37	110	10417	0.00	71	10473	0.53	65
19.2k	19.23k	0.16	155	19.20k	0.00	59	19.23k	0.16	38	19.20k	0.00	35
57.6k	57.69k	0.16	51	57.60k	0.00	19	57.69k	0.16	12	57.60k	0.00	11
115.2k	115.38k	0.16	25	115.2k	0.00	9	—	—	—	115.2k	0.00	5

BAUD RATE	SYNC = 0, BRGH = 0, BRG16 = 1											
	Fosc = 8.000 MHz			Fosc = 4.000 MHz			Fosc = 3.6864 MHz			Fosc = 1.000 MHz		
	Actual Rate	% Error	SPBRGH :SPBRG (decimal)	Actual Rate	% Error	SPBRGH :SPBRG (decimal)	Actual Rate	% Error	SPBRGH :SPBRG (decimal)	Actual Rate	% Error	SPBRGH :SPBRG (decimal)
300	299.9	-0.02	1666	300.1	0.04	832	300.0	0.00	767	300.5	0.16	207
1200	1199	-0.08	416	1202	0.16	207	1200	0.00	191	1202	0.16	51
2400	2404	0.16	207	2404	0.16	103	2400	0.00	95	2404	0.16	25
9600	9615	0.16	51	9615	0.16	25	9600	0.00	23	—	—	—
10417	10417	0.00	47	10417	0.00	23	10473	0.53	21	10417	0.00	5
19.2k	19.23k	0.16	25	19.23k	0.16	12	19.20k	0.00	11	—	—	—
57.6k	55556	-3.55	8	—	—	—	57.60k	0.00	3	—	—	—
115.2k	—	—	—	—	—	—	115.2k	0.00	1	—	—	—

# PIC18(L)F1XK22

**TABLE 15-5: BAUD RATES FOR ASYNCHRONOUS MODES (CONTINUED)**

BAUD RATE	SYNC = 0, BRGH = 1, BRG16 = 1 or SYNC = 1, BRG16 = 1											
	Fosc = 48.000 MHz			Fosc = 18.432 MHz			Fosc = 12.000 MHz			Fosc = 11.0592 MHz		
	Actual Rate	% Error	SPBRGH :SPBRG (decimal)	Actual Rate	% Error	SPBRGH :SPBRG (decimal)	Actual Rate	% Error	SPBRGH :SPBRG (decimal)	Actual Rate	% Error	SPBRGH :SPBRG (decimal)
300	300	0.00	39999	300.0	0.00	15359	300	0.00	9999	300.0	0.00	9215
1200	1200	0.00	9999	1200	0.00	3839	1200	0.00	2499	1200	0.00	2303
2400	2400	0.00	4999	2400	0.00	1919	2400	0.00	1249	2400	0.00	1151
9600	9600	0.00	1249	9600	0.00	479	9615	0.16	311	9600	0.00	287
10417	10417	0.00	1151	10425	0.08	441	10417	0.00	287	10433	0.16	264
19.2k	19.20k	0.00	624	19.20k	0.00	239	19.23k	0.16	155	19.20k	0.00	143
57.6k	57.69k	0.16	207	57.60k	0.00	79	57.69k	0.16	51	57.60k	0.00	47
115.2k	115.38k	0.16	103	115.2k	0.00	39	115.38k	0.16	25	115.2k	0.00	23

BAUD RATE	SYNC = 0, BRGH = 1, BRG16 = 1 or SYNC = 1, BRG16 = 1											
	Fosc = 8.000 MHz			Fosc = 4.000 MHz			Fosc = 3.6864 MHz			Fosc = 1.000 MHz		
	Actual Rate	% Error	SPBRGH :SPBRG (decimal)	Actual Rate	% Error	SPBRGH :SPBRG (decimal)	Actual Rate	% Error	SPBRGH :SPBRG (decimal)	Actual Rate	% Error	SPBRGH :SPBRG (decimal)
300	300.0	0.00	6666	300.0	0.01	3332	300.0	0.00	3071	300.1	0.04	832
1200	1200	-0.02	1666	1200	0.04	832	1200	0.00	767	1202	0.16	207
2400	2401	0.04	832	2398	0.08	416	2400	0.00	383	2404	0.16	103
9600	9615	0.16	207	9615	0.16	103	9600	0.00	95	9615	0.16	25
10417	10417	0.00	191	10417	0.00	95	10473	0.53	87	10417	0.00	23
19.2k	19.23k	0.16	103	19.23k	0.16	51	19.20k	0.00	47	19.23k	0.16	12
57.6k	57.14k	-0.79	34	58.82k	2.12	16	57.60k	0.00	15	—	—	—
115.2k	117.6k	2.12	16	111.1k	-3.55	8	115.2k	0.00	7	—	—	—

## 15.3.1 AUTO-BAUD DETECT

The EUSART module supports automatic detection and calibration of the baud rate.

In the Auto-Baud Detect (ABD) mode, the clock to the BRG is reversed. Rather than the BRG clocking the incoming RX signal, the RX signal is timing the BRG. The Baud Rate Generator is used to time the period of a received 55h (ASCII “U”), which is the Sync character for the LIN bus. The unique feature of this character is that it has five rising edges including the Stop bit edge.

Setting the ABDEN bit of the BAUDCON register starts the auto-baud calibration sequence (Figure 15-6). While the ABD sequence takes place, the EUSART state machine is held in Idle. On the first rising edge of the receive line, after the Start bit, the SPBRG begins counting up using the BRG counter clock as shown in Table 15-6. The fifth rising edge will occur on the RX pin at the end of the eighth bit period. At that time, an accumulated value totaling the proper BRG period is left in the SPBRGH:SPBRG register pair, the ABDEN bit is automatically cleared, and the RCIF interrupt flag is set. A read operation on the RCREG needs to be performed to clear the RCIF interrupt. RCREG content should be discarded. When calibrating for modes that do not use the SPBRGH register the user can verify that the SPBRG register did not overflow by checking for 00h in the SPBRGH register.

The BRG auto-baud clock is determined by the BRG16 and BRGH bits as shown in Table 15-6. During ABD, both the SPBRGH and SPBRG registers are used as a 16-bit counter, independent of the BRG16 bit setting. While calibrating the baud rate period, the SPBRGH

and SPBRG registers are clocked at 1/8th the BRG base clock rate. The resulting byte measurement is the average bit time when clocked at full speed.

**Note 1:** If the WUE bit is set with the ABDEN bit, auto-baud detection will occur on the byte following the Break character (see Section 15.3.3 “Auto-Wake-up on Break”).

**2:** It is up to the user to determine that the incoming character baud rate is within the range of the selected BRG clock source. Some combinations of oscillator frequency and EUSART baud rates are not possible.

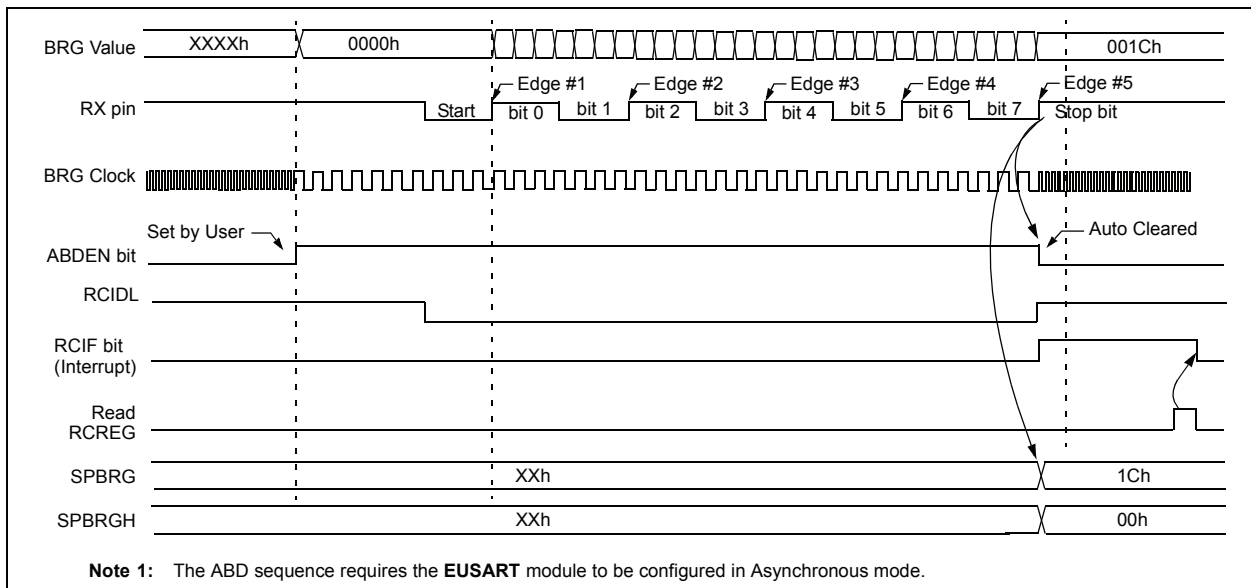
**3:** During the auto-baud process, the auto-baud counter starts counting at 1. Upon completion of the auto-baud sequence, to achieve maximum accuracy, subtract 1 from the SPBRGH:SPBRG register pair.

**TABLE 15-6: BRG COUNTER CLOCK RATES**

BRG16	BRGH	BRG Base Clock	BRG ABD Clock
0	0	Fosc/64	Fosc/512
0	1	Fosc/16	Fosc/128
1	0	Fosc/16	Fosc/128
1	1	Fosc/4	Fosc/32

**Note:** During the ABD sequence, SPBRG and SPBRGH registers are both used as a 16-bit counter, independent of BRG16 setting.

**FIGURE 15-6: AUTOMATIC BAUD RATE CALIBRATION**



# PIC18(L)F1XK22

---

## 15.3.2 AUTO-BAUD OVERFLOW

During the course of automatic baud detection, the ABDOVF bit of the BAUDCON register will be set if the baud rate counter overflows before the fifth rising edge is detected on the RX pin. The ABDOVF bit indicates that the counter has exceeded the maximum count that can fit in the 16 bits of the SPBRGH:SPBRG register pair. After the ABDOVF has been set, the counter continues to count until the fifth rising edge is detected on the RX pin. Upon detecting the fifth RX edge, the hardware will set the RCIF Interrupt Flag and clear the ABDEN bit of the BAUDCON register. The RCIF flag can be subsequently cleared by reading the RCREG register. The ABDOVF flag of the BAUDCON register can be cleared by software directly.

To terminate the auto-baud process before the RCIF flag is set, clear the ABDEN bit then clear the ABDOVF bit of the BAUDCON register. The ABDOVF bit will remain set if the ABDEN bit is not cleared first.

## 15.3.3 AUTO-WAKE-UP ON BREAK

During Sleep mode, all clocks to the EUSART are suspended. Because of this, the Baud Rate Generator is inactive and a proper character reception cannot be performed. The Auto-Wake-up feature allows the controller to wake-up due to activity on the RX/DT line. This feature is available only in Asynchronous mode.

The Auto-Wake-up feature is enabled by setting the WUE bit of the BAUDCON register. Once set, the normal receive sequence on RX/DT is disabled, and the EUSART remains in an Idle state, monitoring for a wake-up event independent of the CPU mode. A wake-up event consists of a high-to-low transition on the RX/DT line. (This coincides with the start of a Sync Break or a wake-up signal character for the LIN protocol.)

The EUSART module generates an RCIF interrupt coincident with the wake-up event. The interrupt is generated synchronously to the Q clocks in normal CPU operating modes (Figure 15-7), and asynchronously if the device is in Sleep mode (Figure 15-8). The interrupt condition is cleared by reading the RCREG register.

The WUE bit is automatically cleared by the low-to-high transition on the RX line at the end of the Break. This signals to the user that the Break event is over. At this point, the EUSART module is in Idle mode waiting to receive the next character.

## 15.3.3.1 Special Considerations

### Break Character

To avoid character errors or character fragments during a wake-up event, the wake-up character must be all zeros.

When the wake-up is enabled the function works independent of the low time on the data stream. If the WUE bit is set and a valid non-zero character is received, the low time from the Start bit to the first rising edge will be interpreted as the wake-up event. The remaining bits in the character will be received as a fragmented character and subsequent characters can result in framing or overrun errors.

Therefore, the initial character in the transmission must be all '0's. This must be 10 or more bit times, 13-bit times recommended for LIN bus, or any number of bit times for standard RS-232 devices.

### Oscillator Startup Time

Oscillator start-up time must be considered, especially in applications using oscillators with longer start-up intervals (i.e., LP, XT or HS/PLL mode). The Sync Break (or wake-up signal) character must be of sufficient length, and be followed by a sufficient interval, to allow enough time for the selected oscillator to start and provide proper initialization of the EUSART.

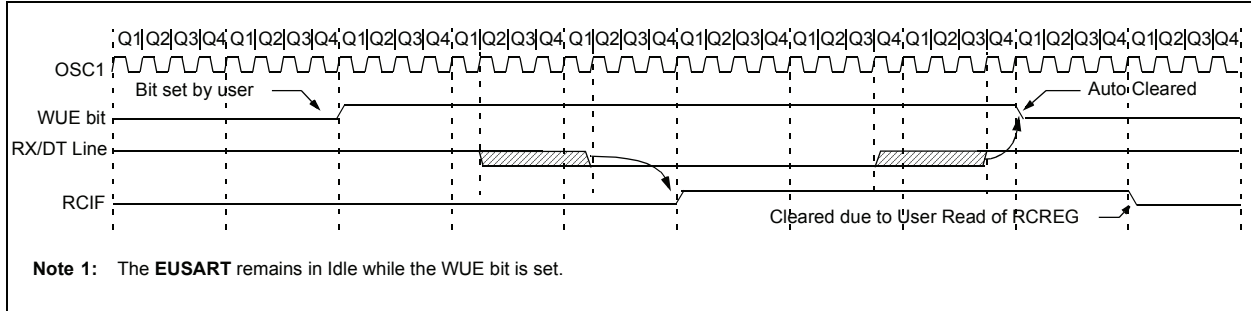
### WUE Bit

The wake-up event causes a receive interrupt by setting the RCIF bit. The WUE bit is cleared by hardware by a rising edge on RX/DT. The interrupt condition is then cleared by software by reading the RCREG register and discarding its contents.

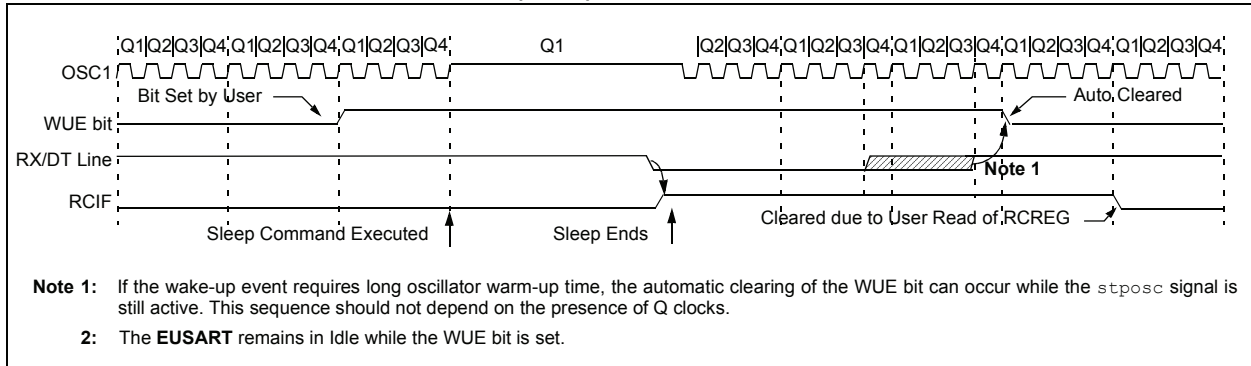
To ensure that no actual data is lost, check the RCIDL bit to verify that a receive operation is not in process before setting the WUE bit. If a receive operation is not occurring, the WUE bit may then be set just prior to entering the Sleep mode.



**FIGURE 15-7: AUTO-WAKE-UP BIT (WUE) TIMING DURING NORMAL OPERATION**



**FIGURE 15-8: AUTO-WAKE-UP BIT (WUE) TIMINGS DURING SLEEP**



# PIC18(L)F1XK22

## 15.3.4 BREAK CHARACTER SEQUENCE

The EUSART module has the capability of sending the special Break character sequences that are required by the LIN bus standard. A Break character consists of a Start bit, followed by 12 '0' bits and a Stop bit.

To send a Break character, set the SENDB and TXEN bits of the TXSTA register. The Break character transmission is then initiated by a write to the TXREG. The value of data written to TXREG will be ignored and all '0's will be transmitted.

The SENDB bit is automatically reset by hardware after the corresponding Stop bit is sent. This allows the user to preload the transmit FIFO with the next transmit byte following the Break character (typically, the Sync character in the LIN specification).

The TRMT bit of the TXSTA register indicates when the transmit operation is active or Idle, just as it does during normal transmission. See [Figure 15-9](#) for the timing of the Break character sequence.

### 15.3.4.1 Break and Sync Transmit Sequence

The following sequence will start a message frame header made up of a Break, followed by an auto-baud Sync byte. This sequence is typical of a LIN bus master.

1. Configure the EUSART for the desired mode.
2. Set the TXEN and SENDB bits to enable the Break sequence.
3. Load the TXREG with a dummy character to initiate transmission (the value is ignored).
4. Write '55h' to TXREG to load the Sync character into the transmit FIFO buffer.
5. After the Break has been sent, the SENDB bit is reset by hardware and the Sync character is then transmitted.

When the TXREG becomes empty, as indicated by the TXIF, the next data byte can be written to TXREG.

## 15.3.5 RECEIVING A BREAK CHARACTER

The Enhanced EUSART module can receive a Break character in two ways.

The first method to detect a Break character uses the FERR bit of the RCSTA register and the Received data as indicated by RCREG. The Baud Rate Generator is assumed to have been initialized to the expected baud rate.

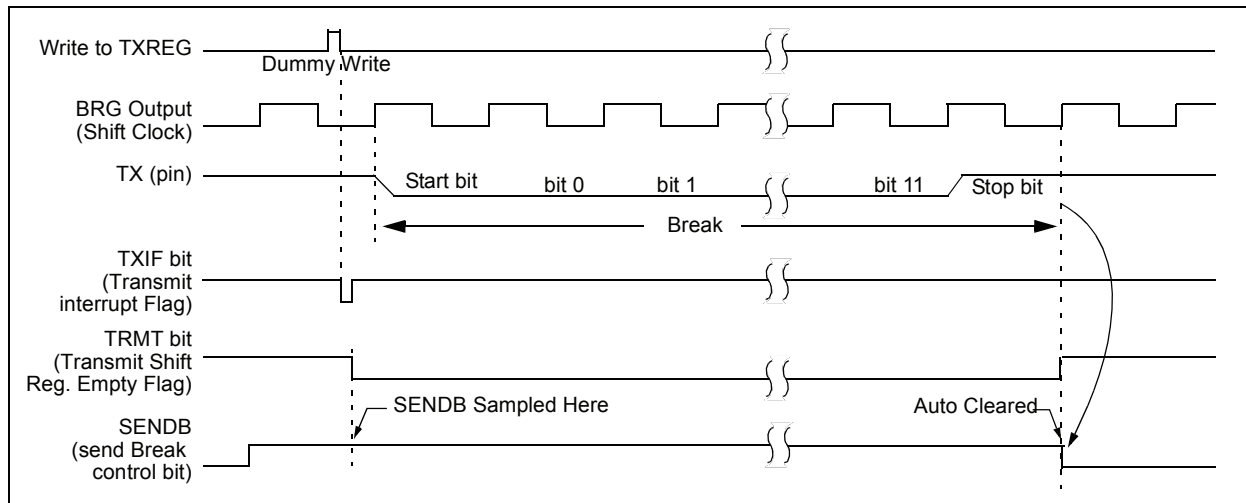
A Break character has been received when;

- RCIF bit is set
- FERR bit is set
- RCREG = 00h

The second method uses the Auto-Wake-up feature described in [Section 15.3.3 "Auto-Wake-up on Break"](#). By enabling this feature, the EUSART will sample the next two transitions on RX/DT, cause an RCIF interrupt, and receive the next data byte followed by another interrupt.

Note that following a Break character, the user will typically want to enable the Auto-Baud Detect feature. For both methods, the user can set the ABDEN bit of the BAUDCON register before placing the EUSART in Sleep mode.

**FIGURE 15-9: SEND BREAK CHARACTER SEQUENCE**



## 15.4 EUSART Synchronous Mode

Synchronous serial communications are typically used in systems with a single master and one or more slaves. The master device contains the necessary circuitry for baud rate generation and supplies the clock for all devices in the system. Slave devices can take advantage of the master clock by eliminating the internal clock generation circuitry.

There are two signal lines in Synchronous mode: a bidirectional data line and a clock line. Slaves use the external clock supplied by the master to shift the serial data into and out of their respective receive and transmit shift registers. Since the data line is bidirectional, synchronous operation is half-duplex only. Half-duplex refers to the fact that master and slave devices can receive and transmit data but not both simultaneously. The EUSART can operate as either a master or slave device.

Start and Stop bits are not used in synchronous transmissions.

### 15.4.1 SYNCHRONOUS MASTER MODE

The following bits are used to configure the EUSART for synchronous master operation:

- SYNC = 1
- CSRC = 1
- SREN = 0 (for transmit); SREN = 1 (for receive)
- CREN = 0 (for transmit); CREN = 1 (for receive)
- SPEN = 1

Setting the SYNC bit of the TXSTA register configures the device for synchronous operation. Setting the CSRC bit of the TXSTA register configures the device as a master. Clearing the SREN and CREN bits of the RCSTA register ensures that the device is in the Transmit mode, otherwise the device will be configured to receive. Setting the SPEN bit of the RCSTA register enables the EUSART. If the RX/DT or TX/CK pins are shared with an analog peripheral the analog I/O functions must be disabled by clearing the corresponding ANSEL bits.

The TRIS bits corresponding to the RX/DT and TX/CK pins should be set.

#### 15.4.1.1 Master Clock

Synchronous data transfers use a separate clock line, which is synchronous with the data. A device configured as a master transmits the clock on the TX/CK line. The TX/CK pin output driver is automatically enabled when the EUSART is configured for synchronous transmit or receive operation. Serial data bits change on the leading edge to ensure they are valid at the trailing edge of each clock. One clock cycle is generated for each data bit. Only as many clock cycles are generated as there are data bits.

#### 15.4.1.2 Clock Polarity

A clock polarity option is provided for Microwire compatibility. Clock polarity is selected with the CKTXP bit of the BAUDCON register. Setting the CKTXP bit sets the clock Idle state as high. When the CKTXP bit is set, the data changes on the falling edge of each clock and is sampled on the rising edge of each clock. Clearing the CKTXP bit sets the Idle state as low. When the CKTXP bit is cleared, the data changes on the rising edge of each clock and is sampled on the falling edge of each clock.

#### 15.4.1.3 Synchronous Master Transmission

Data is transferred out of the device on the RX/DT pin. The RX/DT and TX/CK pin output drivers are automatically enabled when the EUSART is configured for synchronous master transmit operation.

A transmission is initiated by writing a character to the TXREG register. If the TSR still contains all or part of a previous character the new character data is held in the TXREG until the last bit of the previous character has been transmitted. If this is the first character, or the previous character has been completely flushed from the TSR, the data in the TXREG is immediately transferred to the TSR. The transmission of the character commences immediately following the transfer of the data to the TSR from the TXREG.

Each data bit changes on the leading edge of the master clock and remains valid until the subsequent leading clock edge.

<b>Note:</b> The TSR register is not mapped in data memory, so it is not available to the user.
---

#### 15.4.1.4 Data Polarity

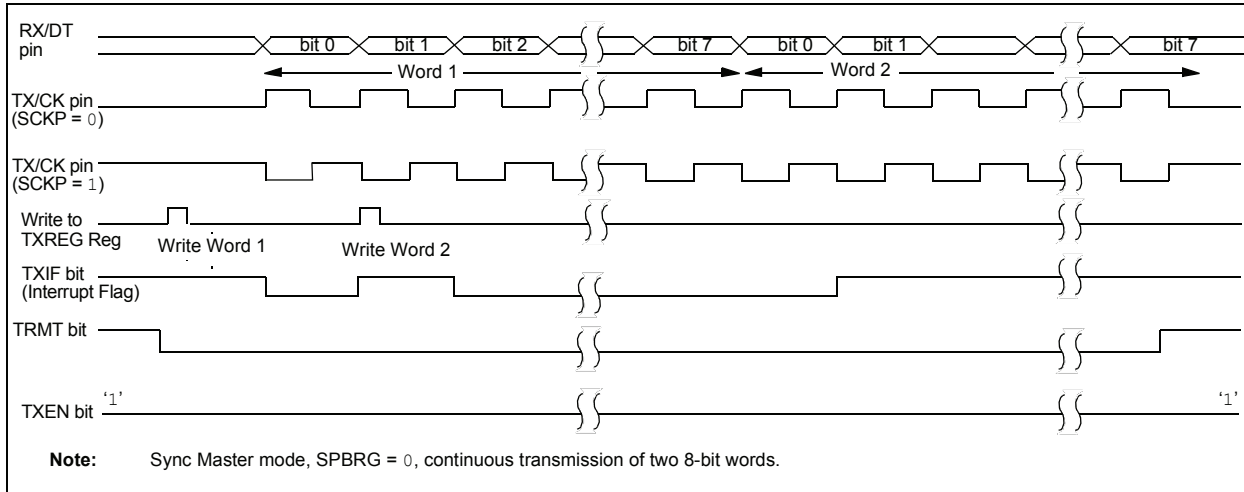
The polarity of the transmit and receive data can be controlled with the DTRXP bit of the BAUDCON register. The default state of this bit is '0' which selects high true transmit and receive data. Setting the DTRXP bit to '1' will invert the data resulting in low true transmit and receive data.

# PIC18(L)F1XK22

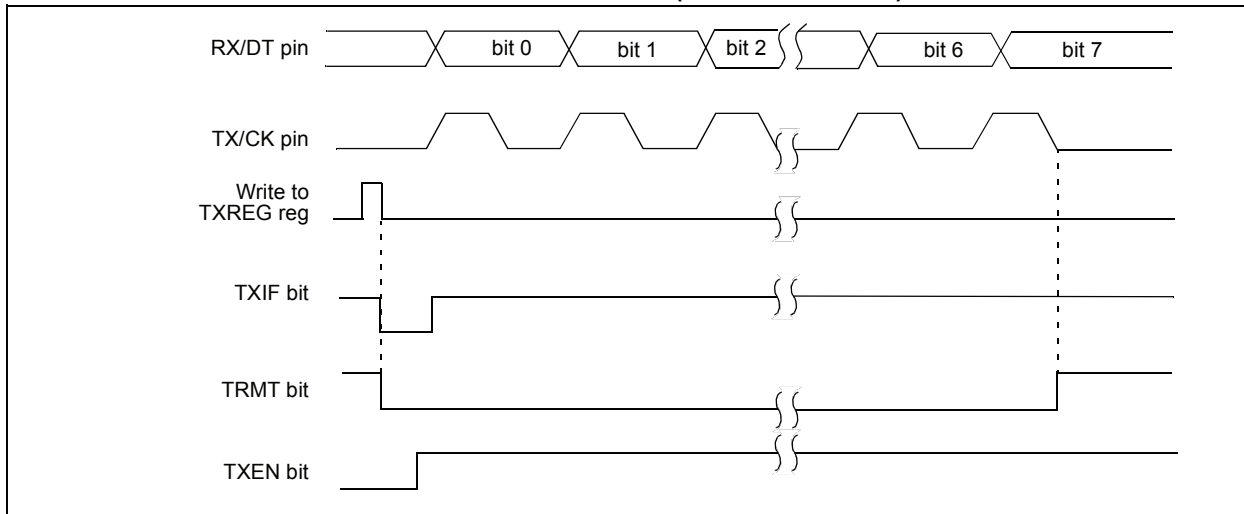
## 15.4.1.5 Synchronous Master Transmission Set-up:

1. Initialize the SPBRGH, SPBRG register pair and the BRGH and BRG16 bits to achieve the desired baud rate (see [Section 15.3 “EUSART Baud Rate Generator \(BRG\)”](#)).
2. Enable the synchronous master serial port by setting bits SYNC, SPEN and CSRC. Set the TRIS bits corresponding to the RX/DT and TX/CK I/O pins.
3. Disable Receive mode by clearing bits SREN and CREN.
4. Enable Transmit mode by setting the TXEN bit.
5. If 9-bit transmission is desired, set the TX9 bit.
6. If interrupts are desired, set the TXIE, GIE and PEIE interrupt enable bits.
7. If 9-bit transmission is selected, the ninth bit should be loaded in the TX9D bit.
8. Start transmission by loading data to the TXREG register.

**FIGURE 15-10: SYNCHRONOUS TRANSMISSION**



**FIGURE 15-11: SYNCHRONOUS TRANSMISSION (THROUGH TXEN)**



**TABLE 15-7: REGISTERS ASSOCIATED WITH SYNCHRONOUS MASTER TRANSMISSION**

Name	Bit 7	Bit 6	Bit 5	Bit 4	Bit 3	Bit 2	Bit 1	Bit 0	Reset Values on page
BAUDCON	ABDOVF	RCIDL	DTRXP	CKTXP	BRG16	—	WUE	ABDEN	255
INTCON	GIE/GIEH	PEIE/GIEL	TMR0IE	INT0IE	RABIE	TMR0IF	INT0IF	RABIF	253
IPR1	—	ADIP	RCIP	TXIP	SSPIP	CCP1IP	TMR2IP	TMR1IP	256
PIE1	—	ADIE	RCIE	TXIE	SSPIE	CCP1IE	TMR2IE	TMR1IE	256
PIR1	—	ADIF	RCIF	TXIF	SSPIF	CCP1IF	TMR2IF	TMR1IF	256
RCSTA	SPEN	RX9	SREN	CREN	ADDEN	FERR	OERR	RX9D	255
SPBRG	EUSART Baud Rate Generator Register, Low Byte								255
SPBRGH	EUSART Baud Rate Generator Register, High Byte								255
TRISC	TRISC7	TRISC6	TRISC5	TRISC4	TRISC3	TRISC2	TRISC1	TRISC0	256
TXREG	EUSART Transmit Register								255
TXSTA	CSRC	TX9	TXEN	SYNC	SENDB	BRGH	TRMT	TX9D	255

**Legend:** — = unimplemented, read as '0'. Shaded cells are not used for synchronous master transmission.

#### 15.4.1.6 Synchronous Master Reception

Data is received at the RX/DT pin. The RX/DT pin output driver must be disabled by setting the corresponding TRIS bits when the EUSART is configured for synchronous master receive operation.

In Synchronous mode, reception is enabled by setting either the Single Receive Enable bit (SREN of the RCSTA register) or the Continuous Receive Enable bit (CREN of the RCSTA register).

When SREN is set and CREN is clear, only as many clock cycles are generated as there are data bits in a single character. The SREN bit is automatically cleared at the completion of one character. When CREN is set, clocks are continuously generated until CREN is cleared. If CREN is cleared in the middle of a character the CK clock stops immediately and the partial character is discarded. If SREN and CREN are both set, then SREN is cleared at the completion of the first character and CREN takes precedence.

To initiate reception, set either SREN or CREN. Data is sampled at the RX/DT pin on the trailing edge of the TX/CK clock pin and is shifted into the Receive Shift Register (RSR). When a complete character is received into the RSR, the RCIF bit is set and the character is automatically transferred to the two character receive FIFO. The Least Significant eight bits of the top character in the receive FIFO are available in RCREG. The RCIF bit remains set as long as there are unread characters in the receive FIFO.

#### 15.4.1.7 Slave Clock

Synchronous data transfers use a separate clock line, which is synchronous with the data. A device configured as a slave receives the clock on the TX/CK line. The TX/CK pin output driver must be disabled by setting the associated TRIS bit when the device is configured for synchronous slave transmit or receive operation. Serial data bits change on the leading edge to ensure they are valid at the trailing edge of each clock. One data bit is transferred for each clock cycle. Only as many clock cycles should be received as there are data bits.

#### 15.4.1.8 Receive Overrun Error

The receive FIFO buffer can hold two characters. An overrun error will be generated if a third character, in its entirety, is received before RCREG is read to access the FIFO. When this happens the OERR bit of the RCSTA register is set. Previous data in the FIFO will not be overwritten. The two characters in the FIFO buffer can be read, however, no additional characters will be received until the error is cleared. The OERR bit can only be cleared by clearing the overrun condition. If the overrun error occurred when the SREN bit is set and CREN is clear then the error is cleared by reading RCREG. If the overrun occurred when the CREN bit is set then the error condition is cleared by either clearing the CREN bit of the RCSTA register or by clearing the SPEN bit which resets the EUSART.

# PIC18(L)F1XK22

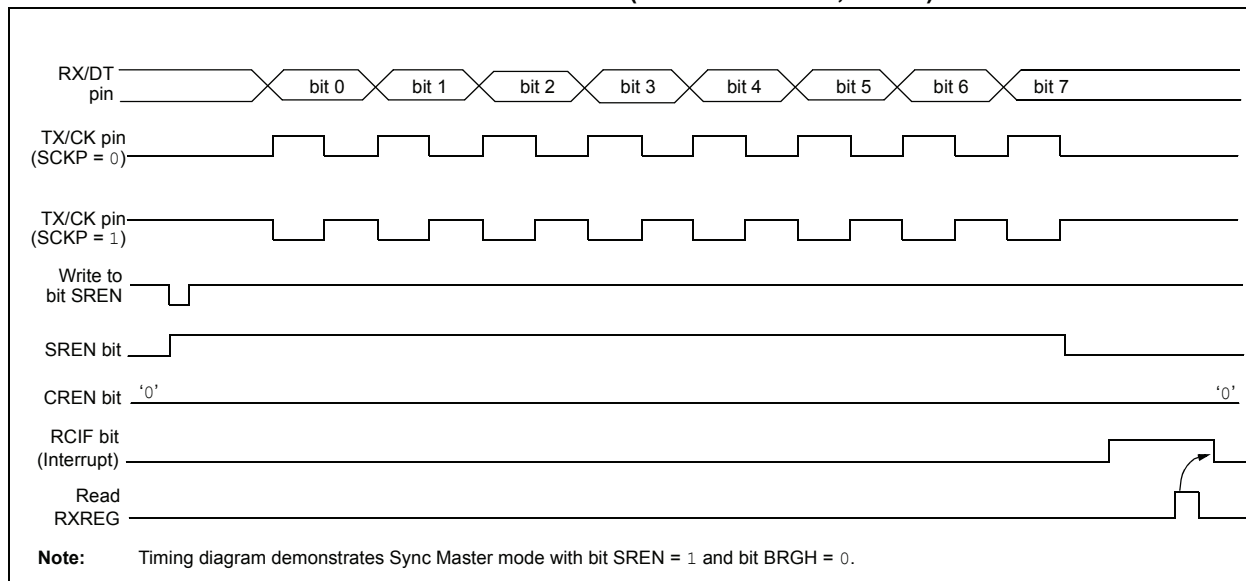
## 15.4.1.9 Receiving 9-bit Characters

The EUSART supports 9-bit character reception. When the RX9 bit of the RCSTA register is set the EUSART will shift 9-bits into the RSR for each character received. The RX9D bit of the RCSTA register is the ninth, and Most Significant, data bit of the top unread character in the receive FIFO. When reading 9-bit data from the receive FIFO buffer, the RX9D data bit must be read before reading the 8 Least Significant bits from the RCREG.

## 15.4.1.10 Synchronous Master Reception Set-up:

1. Initialize the SPBRGH, SPBRG register pair for the appropriate baud rate. Set or clear the BRGH and BRG16 bits, as required, to achieve the desired baud rate.
2. Enable the synchronous master serial port by setting bits SYNC, SPEN and CSRC. Disable RX/DT and TX/CK output drivers by setting the corresponding TRIS bits.
3. Ensure bits CREN and SREN are clear.
4. If using interrupts, set the GIE and PEIE bits of the INTCON register and set RCIE.
5. If 9-bit reception is desired, set bit RX9.
6. Start reception by setting the SREN bit or for continuous reception, set the CREN bit.
7. Interrupt flag bit RCIF will be set when reception of a character is complete. An interrupt will be generated if the enable bit RCIE was set.
8. Read the RCSTA register to get the ninth bit (if enabled) and determine if any error occurred during reception.
9. Read the 8-bit received data by reading the RCREG register.
10. If an overrun error occurs, clear the error by either clearing the CREN bit of the RCSTA register or by clearing the SPEN bit which resets the EUSART.

**FIGURE 15-12: SYNCHRONOUS RECEPTION (MASTER MODE, SREN)**



**TABLE 15-8: REGISTERS ASSOCIATED WITH SYNCHRONOUS MASTER RECEPTION**

Name	Bit 7	Bit 6	Bit 5	Bit 4	Bit 3	Bit 2	Bit 1	Bit 0	Reset Values on page
BAUDCON	ABDOVF	RCIDL	DTRXP	CKTXP	BRG16	—	WUE	ABDEN	255
INTCON	GIE/GIEH	PEIE/GIEL	TMR0IE	INT0IE	RABIE	TMR0IF	INT0IF	RABIF	253
IPR1	—	ADIP	RCIP	TXIP	SSPIP	CCP1IP	TMR2IP	TMR1IP	256
PIE1	—	ADIE	RCIE	TXIE	SSPIE	CCP1IE	TMR2IE	TMR1IE	256
PIR1	—	ADIF	RCIF	TXIF	SSPIF	CCP1IF	TMR2IF	TMR1IF	256
RCREG	EUSART Receive Register								255
RCSTA	SPEN	RX9	SREN	CREN	ADDEN	FERR	OERR	RX9D	255
SPBRG	EUSART Baud Rate Generator Register, Low Byte								255
SPBRGH	EUSART Baud Rate Generator Register, High Byte								255
TXSTA	CSRC	TX9	TXEN	SYNC	SEnDB	BRGH	TRMT	TX9D	255

**Legend:** — = unimplemented, read as '0'. Shaded cells are not used for synchronous master reception.

# PIC18(L)F1XK22

## 15.4.2 SYNCHRONOUS SLAVE MODE

The following bits are used to configure the EUSART for synchronous slave operation:

- SYNC = 1
- CSRC = 0
- SREN = 0 (for transmit); SREN = 1 (for receive)
- CREN = 0 (for transmit); CREN = 1 (for receive)
- SPEN = 1

Setting the SYNC bit of the TXSTA register configures the device for synchronous operation. Clearing the CSRC bit of the TXSTA register configures the device as a slave. Clearing the SREN and CREN bits of the RCSTA register ensures that the device is in the Transmit mode, otherwise the device will be configured to receive. Setting the SPEN bit of the RCSTA register enables the EUSART. If the RX/DT or TX/CK pins are shared with an analog peripheral the analog I/O functions must be disabled by clearing the corresponding ANSEL bits.

RX/DT and TX/CK pin output drivers must be disabled by setting the corresponding TRIS bits.

### 15.4.2.1 EUSART Synchronous Slave Transmit

The operation of the Synchronous Master and Slave modes are identical (see [Section 15.4.1.3 “Synchronous Master Transmission”](#)), except in the case of the Sleep mode.

If two words are written to the TXREG and then the SLEEP instruction is executed, the following will occur:

1. The first character will immediately transfer to the TSR register and transmit.
2. The second word will remain in TXREG register.
3. The TXIF bit will not be set.
4. After the first character has been shifted out of TSR, the TXREG register will transfer the second character to the TSR and the TXIF bit will now be set.
5. If the PEIE and TXIE bits are set, the interrupt will wake the device from Sleep and execute the next instruction. If the GIE bit is also set, the program will call the Interrupt Service Routine.

### 15.4.2.2 Synchronous Slave Transmission Set-up:

1. Set the SYNC and SPEN bits and clear the CSRC bit. Set the TRIS bits corresponding to the RX/DT and TX/CK I/O pins.
2. Clear the CREN and SREN bits.
3. If using interrupts, ensure that the GIE and PEIE bits of the INTCON register are set and set the TXIE bit.
4. If 9-bit transmission is desired, set the TX9 bit.
5. Enable transmission by setting the TXEN bit.
6. If 9-bit transmission is selected, insert the Most Significant bit into the TX9D bit.
7. Start transmission by writing the Least Significant 8 bits to the TXREG register.

**TABLE 15-9: REGISTERS ASSOCIATED WITH SYNCHRONOUS SLAVE TRANSMISSION**

Name	Bit 7	Bit 6	Bit 5	Bit 4	Bit 3	Bit 2	Bit 1	Bit 0	Reset Values on page
BAUDCON	ABDOVF	RCIDL	DTRXP	CKTXP	BRG16	—	WUE	ABDEN	255
INTCON	GIE/GIEH	PEIE/GIEL	TMR0IE	INT0IE	RABIE	TMR0IF	INT0IF	RABIF	253
IPR1	—	ADIP	RCIP	TXIP	SSPIP	CCP1IP	TMR2IP	TMR1IP	256
PIE1	—	ADIE	RCIE	TXIE	SSPIE	CCP1IE	TMR2IE	TMR1IE	256
PIR1	—	ADIF	RCIF	TXIF	SSPIF	CCP1IF	TMR2IF	TMR1IF	256
RCSTA	SPEN	RX9	SREN	CREN	ADDEN	FERR	OERR	RX9D	255
SPBRG	EUSART Baud Rate Generator Register, Low Byte								255
SPBRGH	EUSART Baud Rate Generator Register, High Byte								255
TRISC	TRISC7	TRISC6	TRISC5	TRISC4	TRISC3	TRISC2	TRISC1	TRISC0	256
TXREG	EUSART Transmit Register								255
TXSTA	CSRC	TX9	TXEN	SYNC	SENDB	BRGH	TRMT	TX9D	255

**Legend:** — = unimplemented, read as '0'. Shaded cells are not used for synchronous master transmission.



## 15.4.2.3 EUSART Synchronous Slave Reception

The operation of the Synchronous Master and Slave modes is identical ([Section 15.4.1.6 “Synchronous Master Reception”](#)), with the following exceptions:

- Sleep
- CREN bit is always set, therefore the receiver is never Idle
- SREN bit, which is a “don't care” in Slave mode

A character may be received while in Sleep mode by setting the CREN bit prior to entering Sleep. Once the word is received, the RSR register will transfer the data to the RCREG register. If the RCIE enable bit is set, the interrupt generated will wake the device from Sleep and execute the next instruction. If the GIE bit is also set, the program will branch to the interrupt vector.

## 15.4.2.4 Synchronous Slave Reception Set-up:

1. Set the SYNC and SPEN bits and clear the CSRC bit. Set the TRIS bits corresponding to the RX/DT and TX/CK I/O pins.
2. If using interrupts, ensure that the GIE and PEIE bits of the INTCON register are set and set the RCIE bit.
3. If 9-bit reception is desired, set the RX9 bit.
4. Set the CREN bit to enable reception.
5. The RCIF bit will be set when reception is complete. An interrupt will be generated if the RCIE bit was set.
6. If 9-bit mode is enabled, retrieve the Most Significant bit from the RX9D bit of the RCSTA register.
7. Retrieve the 8 Least Significant bits from the receive FIFO by reading the RCREG register.
8. If an overrun error occurs, clear the error by either clearing the CREN bit of the RCSTA register or by clearing the SPEN bit which resets the EUSART.

**TABLE 15-10: REGISTERS ASSOCIATED WITH SYNCHRONOUS SLAVE RECEPTION**

Name	Bit 7	Bit 6	Bit 5	Bit 4	Bit 3	Bit 2	Bit 1	Bit 0	Reset Values on page
BAUDCON	ABDOVF	RCIDL	DTRXP	CKTXP	BRG16	—	WUE	ABDEN	255
INTCON	GIE/GIEH	PEIE/GIEL	TMR0IE	INT0IE	RABIE	TMR0IF	INT0IF	RABIF	253
IPR1	—	ADIP	RCIP	TXIP	SSPIP	CCP1IP	TMR2IP	TMR1IP	256
PIE1	—	ADIE	RCIE	TXIE	SSPIE	CCP1IE	TMR2IE	TMR1IE	256
PIR1	—	ADIF	RCIF	TXIF	SSPIF	CCP1IF	TMR2IF	TMR1IF	256
RCREG	EUSART Receive Register								255
RCSTA	SPEN	RX9	SREN	CREN	ADDEN	FERR	OERR	RX9D	255
SPBRG	EUSART Baud Rate Generator Register, Low Byte								255
SPBRGH	EUSART Baud Rate Generator Register, High Byte								255
TXSTA	CSRC	TX9	TXEN	SYNC	SENDB	BRGH	TRMT	TX9D	255

**Legend:** — = unimplemented, read as '0'. Shaded cells are not used for synchronous slave reception.

# PIC18(L)F1XK22

---

NOTES:

## 16.0 ANALOG-TO-DIGITAL CONVERTER (ADC) MODULE

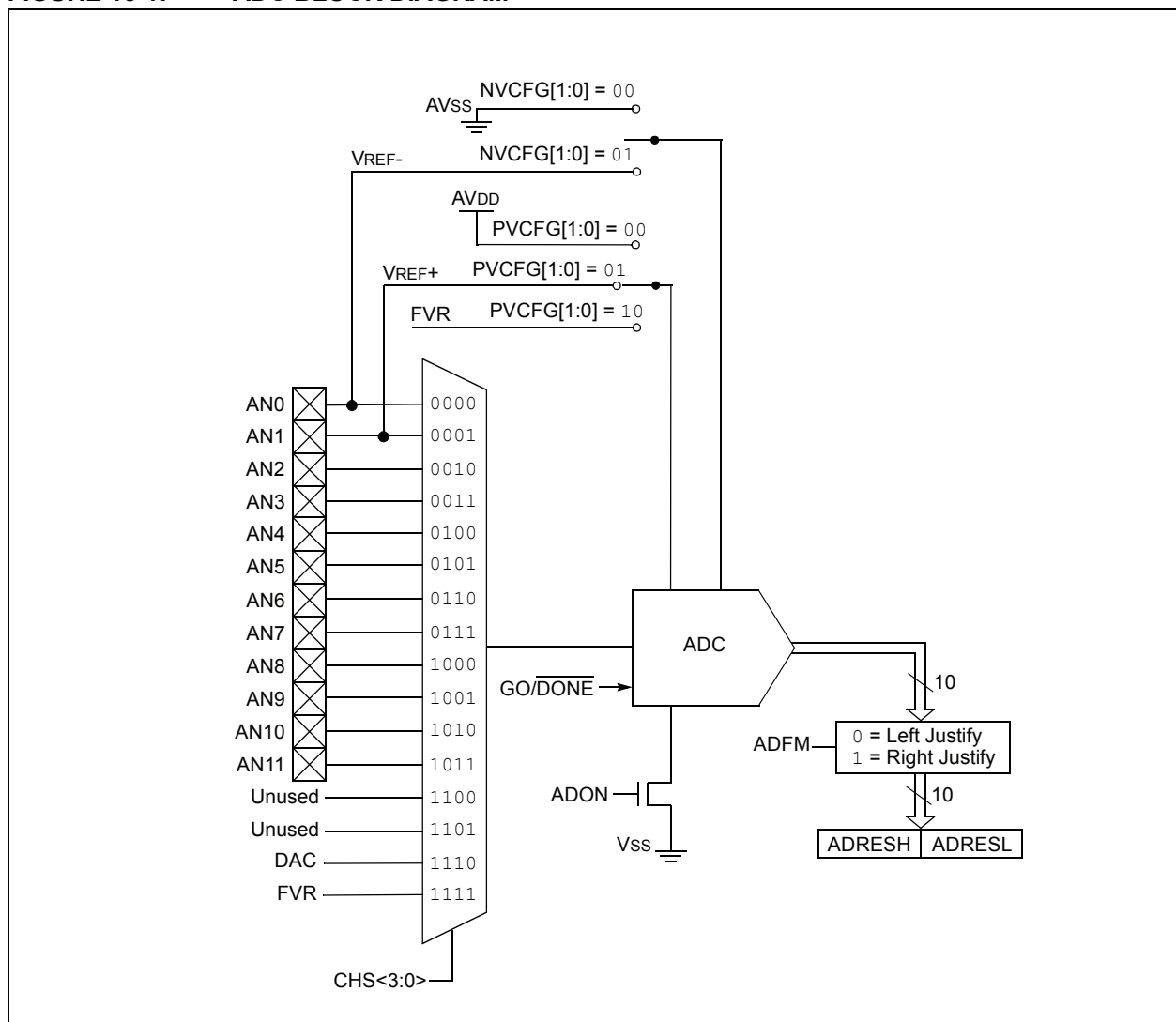
The Analog-to-Digital Converter (ADC) allows conversion of an analog input signal to a 10-bit binary representation of that signal. This device uses analog inputs, which are multiplexed into a single sample and hold circuit. The output of the sample and hold is connected to the input of the converter. The converter generates a 10-bit binary result via successive approximation and stores the conversion result into the ADC result registers (ADRESH and ADRESL).

The ADC voltage reference is software selectable to either VDD, or a voltage applied to the external reference pins.

The ADC can generate an interrupt upon completion of a conversion. This interrupt can be used to wake-up the device from Sleep.

Figure 16-1 shows the block diagram of the ADC.

**FIGURE 16-1: ADC BLOCK DIAGRAM**



# PIC18(L)F1XK22

## 16.1 ADC Configuration

When configuring and using the ADC the following functions must be considered:

- Port configuration
- Channel selection
- ADC voltage reference selection
- ADC conversion clock source
- Interrupt control
- Results formatting

### 16.1.1 PORT CONFIGURATION

The ANSEL, ANSELH, TRISA, TRISB and TRISE registers all configure the A/D port pins. Any port pin needed as an analog input should have its corresponding ANSx bit set to disable the digital input buffer and TRISx bit set to disable the digital output driver. If the TRISx bit is cleared, the digital output level (VOH or VOL) will be converted.

The A/D operation is independent of the state of the ANSx bits and the TRIS bits.

**Note 1:** When reading the PORT register, all pins with their corresponding ANSx bit read as cleared (a low level). However, analog conversion of pins configured as digital inputs (ANSx bit cleared and TRISx bit set) will be accurately converted.

- 2:** Analog levels on any pin with the corresponding ANSx bit cleared may cause the digital input buffer to consume current out of the device's specification limits.

### 16.1.2 CHANNEL SELECTION

The CHS bits of the ADCON0 register determine which channel is connected to the sample and hold circuit.

When changing channels, a delay is required before starting the next conversion. Refer to [Section 16.2 "ADC Operation"](#) for more information.

### 16.1.3 ADC VOLTAGE REFERENCE

The PVCFG and NVCFG bits of the ADCON1 register provide independent control of the positive and negative voltage references, respectively. The positive voltage reference can be either VDD, FVR or an external voltage source. The negative voltage reference can be either VSS or an external voltage source.

### 16.1.4 SELECTING AND CONFIGURING ACQUISITION TIME

The ADCON2 register allows the user to select an acquisition time that occurs each time the GO/DONE bit is set.

Acquisition time is set with the ACQT<2:0> bits of the ADCON2 register. Acquisition delays cover a range of 2 to 20 TAD. When the GO/DONE bit is set, the A/D module continues to sample the input for the selected acquisition time, then automatically begins a conversion. Since the acquisition time is programmed, there is no need to wait for an acquisition time between selecting a channel and setting the GO/DONE bit.

Manual acquisition is selected when ACQT<2:0> = 000. When the GO/DONE bit is set, sampling is stopped and a conversion begins. The user is responsible for ensuring the required acquisition time has passed between selecting the desired input channel and setting the GO/DONE bit. This option is also the default Reset state of the ACQT<2:0> bits and is compatible with devices that do not offer programmable acquisition times.

In either case, when the conversion is completed, the GO/DONE bit is cleared, the ADIF flag is set and the A/D begins sampling the currently selected channel again. When an acquisition time is programmed, there is no indication of when the acquisition time ends and the conversion begins.

### 16.1.5 CONVERSION CLOCK

The source of the conversion clock is software selectable via the ADCS bits of the ADCON2 register. There are seven possible clock options:

- FOSC/2
- FOSC/4
- FOSC/8
- FOSC/16
- FOSC/32
- FOSC/64
- FRC (dedicated internal oscillator)

The time to complete one bit conversion is defined as TAD. One full 10-bit conversion requires 11 TAD periods as shown in [Figure 16-3](#).

For correct conversion, the appropriate TAD specification must be met. See A/D conversion requirements in [Table 25-9](#) for more information. [Table 16-1](#) gives examples of appropriate ADC clock selections.

**Note:** Unless using the FRC, any changes in the system clock frequency will change the ADC clock frequency, which may adversely affect the ADC result.

## 16.1.6 INTERRUPTS

The ADC module allows for the ability to generate an interrupt upon completion of an Analog-to-Digital Conversion. The ADC interrupt flag is the ADIF bit in the PIR1 register. The ADC interrupt enable is the ADIE bit in the PIE1 register. The ADIF bit must be cleared by software.

**Note:** The ADIF bit is set at the completion of every conversion, regardless of whether or not the ADC interrupt is enabled.

This interrupt can be generated while the device is operating or while in Sleep. If the device is in Sleep, the interrupt will wake-up the device. Upon waking from Sleep, the next instruction following the `SLEEP` instruction is always executed. If the user is attempting to wake-up from Sleep and resume in-line code execution, the global interrupt must be disabled. If the global interrupt is enabled, execution will switch to the Interrupt Service Routine. Please see [Section 16.1.6 “Interrupts”](#) for more information.

**TABLE 16-1: ADC CLOCK PERIOD (T<sub>AD</sub>) VS. DEVICE OPERATING FREQUENCIES**

ADC Clock Period (T <sub>AD</sub> )		Device Frequency (F <sub>osc</sub> )			
ADC Clock Source	ADCS<2:0>	48 MHz	16 MHz	4 MHz	1 MHz
F <sub>osc</sub> /2	000	41.67 ns <sup>(2)</sup>	125 ns <sup>(2)</sup>	500 ns <sup>(2)</sup>	2.0 μs
F <sub>osc</sub> /4	100	83.33 ns <sup>(2)</sup>	250 ns <sup>(2)</sup>	1.0 μs	4.0 μs
F <sub>osc</sub> /8	001	167 ns <sup>(2)</sup>	500 ns <sup>(2)</sup>	2.0 μs	8.0 μs <sup>(3)</sup>
F <sub>osc</sub> /16	101	333 ns <sup>(2)</sup>	1.0 μs	4.0 μs	16.0 μs <sup>(3)</sup>
F <sub>osc</sub> /32	010	667 ns <sup>(2)</sup>	2.0 μs	8.0 μs <sup>(3)</sup>	32.0 μs <sup>(3)</sup>
F <sub>osc</sub> /64	110	1.33 μs	4.0 μs	16.0 μs <sup>(3)</sup>	64.0 μs <sup>(3)</sup>
FRC	x11	1-4 μs <sup>(1,4)</sup>	1-4 μs <sup>(1,4)</sup>	1-4 μs <sup>(1,4)</sup>	1-4 μs <sup>(1,4)</sup>

**Legend:** Shaded cells are outside of recommended range.

**Note 1:** The FRC source has a typical T<sub>AD</sub> time of 1.7 μs.

**2:** These values violate the minimum required T<sub>AD</sub> time.

**3:** For faster conversion times, the selection of another clock source is recommended.

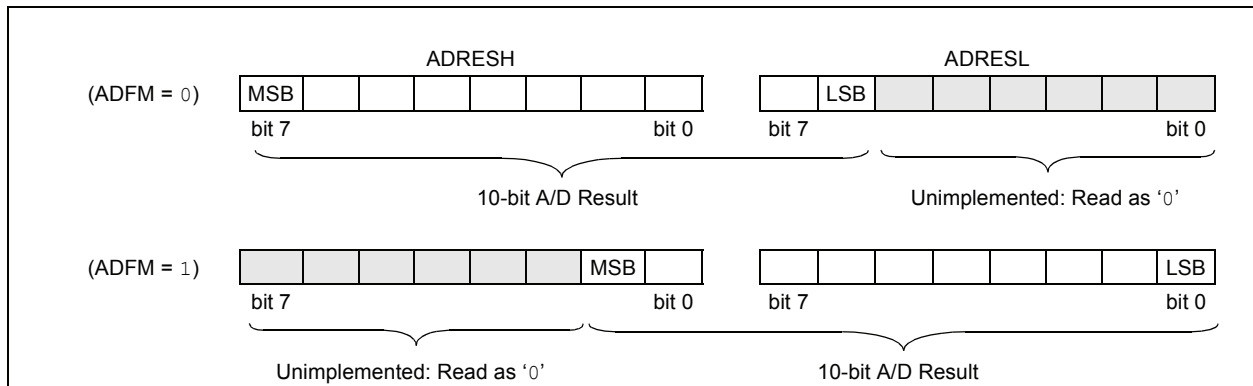
**4:** When the device frequency is greater than 1 MHz, the FRC clock source is only recommended if the conversion will be performed during Sleep.

## 16.1.7 RESULT FORMATTING

The 10-bit A/D conversion result can be supplied in two formats, left justified or right justified. The ADFM bit of the ADCON2 register controls the output format.

Figure 16-2 shows the two output formats.

**FIGURE 16-2: 10-BIT A/D CONVERSION RESULT FORMAT**



# PIC18(L)F1XK22

## 16.2 ADC Operation

### 16.2.1 STARTING A CONVERSION

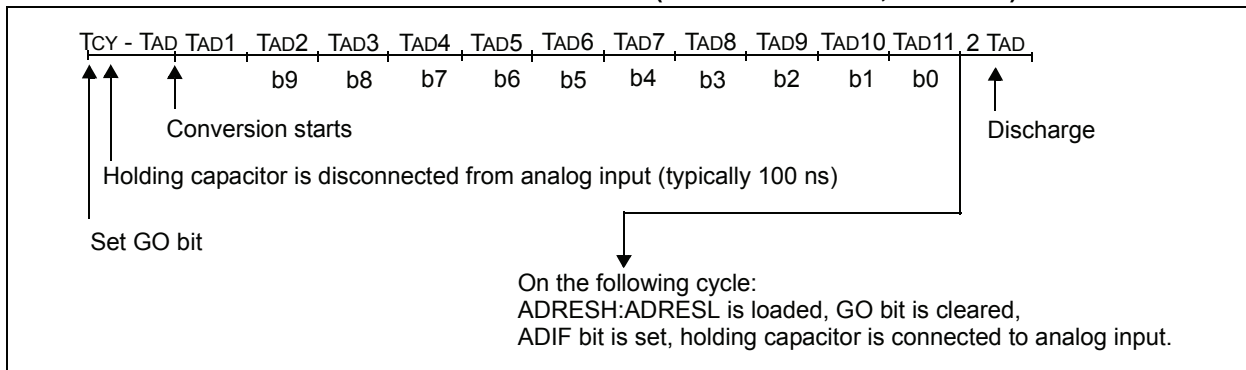
To enable the ADC module, the ADON bit of the `ADCON0` register must be set to a '1'. Setting the `GO/DONE` bit of the `ADCON0` register to a '1' will, depending on the `ACQT` bits of the `ADCON2` register, either immediately start the Analog-to-Digital conversion or start an acquisition delay followed by the Analog-to-Digital conversion.

Figure 16-3 shows the operation of the A/D converter after the `GO` bit has been set and the `ACQT<2:0>` bits are cleared. A conversion is started after the following instruction to allow entry into `SLEEP` mode before the conversion begins.

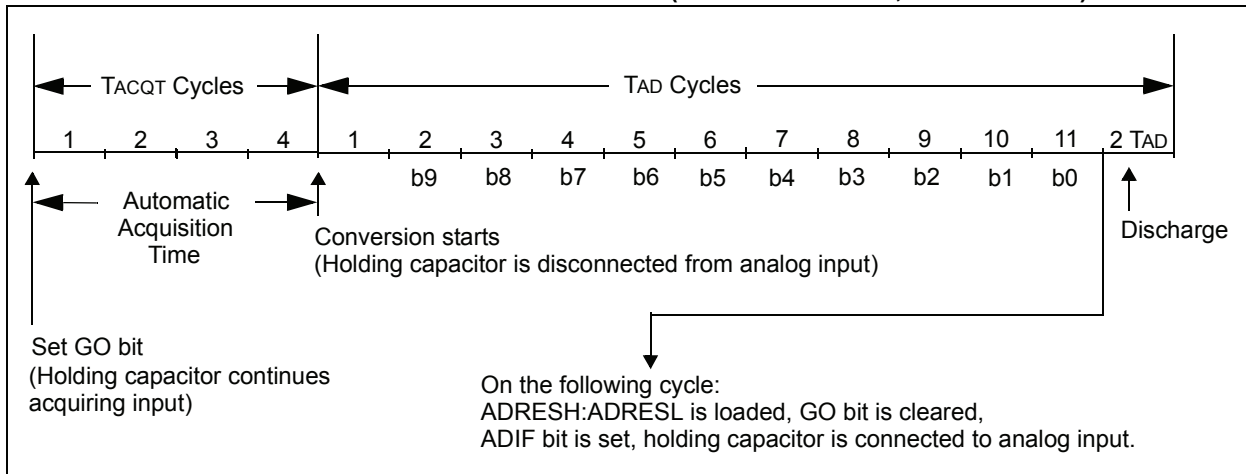
Figure 16-4 shows the operation of the A/D converter after the `GO` bit has been set and the `ACQT<2:0>` bits are set to '010' which selects a 4 TAD acquisition time before the conversion starts.

**Note:** The `GO/DONE` bit should not be set in the same instruction that turns on the ADC. Refer to Section 16.2.9 "A/D Conversion Procedure".

**FIGURE 16-3: A/D CONVERSION TAD CYCLES (`ACQT<2:0> = 000, TACQ = 0`)**



**FIGURE 16-4: A/D CONVERSION TAD CYCLES (`ACQT<2:0> = 010, TACQ = 4 TAD`)**



## 16.2.2 COMPLETION OF A CONVERSION

When the conversion is complete, the ADC module will:

- Clear the  $\overline{\text{GO/DONE}}$  bit
- Set the ADIF flag bit
- Update the ADRESH:ADRESL registers with new conversion result

## 16.2.3 DISCHARGE

The discharge phase is used to initialize the value of the capacitor array. The array is discharged after every sample. This feature helps to optimize the unity-gain amplifier, as the circuit always needs to charge the capacitor array, rather than charge/discharge based on previous measure values.

## 16.2.4 TERMINATING A CONVERSION

If a conversion must be terminated before completion, the  $\overline{\text{GO/DONE}}$  bit can be cleared by software. The ADRESH:ADRESL registers will be updated with the partially complete Analog-to-Digital conversion sample. Unconverted bits will match the last bit converted.

<b>Note:</b> A device Reset forces all registers to their Reset state. Thus, the ADC module is turned off and any pending conversion is terminated.
---

## 16.2.5 DELAY BETWEEN CONVERSIONS

After the A/D conversion is completed or aborted, a 2 TAD wait is required before the next acquisition can be started. After this wait, the currently selected channel is reconnected to the charge holding capacitor commencing the next acquisition.

## 16.2.6 ADC OPERATION IN POWER-MANAGED MODES

The selection of the automatic acquisition time and A/D conversion clock is determined in part by the clock source and frequency while in a power-managed mode.

If the A/D is expected to operate while the device is in a power-managed mode, the ACQT<2:0> and ADCS<2:0> bits in ADCON2 should be updated in accordance with the clock source to be used in that mode. After entering the mode, an A/D acquisition or conversion may be started. Once started, the device should continue to be clocked by the same clock source until the conversion has been completed.

If desired, the device may be placed into the corresponding Idle mode during the conversion. If the device clock frequency is less than 1 MHz, the A/D FRC clock source should be selected.

## 16.2.7 ADC OPERATION DURING SLEEP

The ADC module can operate during Sleep. This requires the ADC clock source to be set to the FRC option. When the FRC clock source is selected, the ADC waits one additional instruction before starting the conversion. This allows the SLEEP instruction to be executed, which can reduce system noise during the conversion. If the ADC interrupt is enabled, the device will wake-up from Sleep when the conversion completes. If the ADC interrupt is disabled, the ADC module is turned off after the conversion completes, although the ADON bit remains set.

When the ADC clock source is something other than FRC, a SLEEP instruction causes the present conversion to be aborted and the ADC module is turned off, although the ADON bit remains set.

## 16.2.8 SPECIAL EVENT TRIGGER

The CCP1 Special Event Trigger allows periodic ADC measurements without software intervention. When this trigger occurs, the  $\overline{\text{GO/DONE}}$  bit is set by hardware and the Timer1 or Timer3 counter resets to zero.

Using the Special Event Trigger does not assure proper ADC timing. It is the user's responsibility to ensure that the ADC timing requirements are met.

See [Section 13.3.4 "Special Event Trigger"](#) for more information.

# PIC18(L)F1XK22

## 16.2.9 A/D CONVERSION PROCEDURE

This is an example procedure for using the ADC to perform an Analog-to-Digital conversion:

1. Configure Port:
  - Disable pin output driver (See TRIS register)
  - Configure pin as analog
2. Configure the ADC module:
  - Select ADC conversion clock
  - Configure voltage reference
  - Select ADC input channel
  - Select result format
  - Select acquisition delay
  - Turn on ADC module
3. Configure ADC interrupt (optional):
  - Clear ADC interrupt flag
  - Enable ADC interrupt
  - Enable peripheral interrupt
  - Enable global interrupt<sup>(1)</sup>
4. Wait the required acquisition time<sup>(2)</sup>.
5. Start conversion by setting the  $\overline{GO}/\overline{DONE}$  bit.
6. Wait for ADC conversion to complete by one of the following:
  - Polling the  $\overline{GO}/\overline{DONE}$  bit
  - Waiting for the ADC interrupt (interrupts enabled)
7. Read ADC Result
8. Clear the ADC interrupt flag (required if interrupt is enabled).

**Note 1:** The global interrupt can be disabled if the user is attempting to wake-up from Sleep and resume in-line code execution.

**2:** Software delay required if ACQT bits are set to zero delay. See [Section 16.3 “A/D Acquisition Requirements”](#).

## EXAMPLE 16-1: A/D CONVERSION

```
;This code block configures the ADC
;for polling, Vdd and Vss as reference, Frc
clock and AN4 input.
;
;Conversion start & polling for completion
; are included.
;
MOVLW    B'10101111' ;right justify, Frc,
MOVWF    ADCON2      ; & 12 TAD ACQ time
MOVLW    B'00000000' ;ADC ref = Vdd,Vss
MOVWF    ADCON1      ;
BSF      TRISC,0      ;Set RC0 to input
BSF      ANSEL,4      ;Set RC0 to analog
MOVLW    B'00010001' ;AN4, ADC on
MOVWF    ADCON0      ;
BSF      ADCON0,GO    ;Start conversion
ADCPoll:
BTFSC    ADCON0,GO    ;Is conversion done?
BRA      ADCPoll      ;No, test again
; Result is complete - store 2 MSbits in
; RESULTHI and 8 LSbits in RESULTLO
MOVFF    ADRESH,RESULTHI
MOVFF    ADRESL,RESULTLO
```



## 16.2.10 ADC REGISTER DEFINITIONS

The following registers are used to control the operation of the ADC.

**Note:** Analog pin control is performed by the ANSEL and ANSELH registers. For ANSEL and ANSELH registers, see [Register 8-14](#) and [Register 8-15](#), respectively.

### REGISTER 16-1: ADCON0: A/D CONTROL REGISTER 0

U-0	U-0	R/W-0	R/W-0	R/W-0	R/W-0	R/W-0	R/W-0
—	—	CHS3	CHS2	CHS1	CHS0	GO/DONE	ADON
bit 7							bit 0

**Legend:**

R = Readable bit	W = Writable bit	U = Unimplemented bit, read as '0'
-n = Value at POR	'1' = Bit is set	'0' = Bit is cleared
		x = Bit is unknown

bit 7-6      **Unimplemented:** Read as '0'

bit 5-2      **CHS<3:0>: Analog Channel Select bits**

- 0000 = AN0
- 0001 = AN1
- 0010 = AN2
- 0011 = AN3
- 0100 = AN4
- 0101 = AN5
- 0110 = AN6
- 0111 = AN7
- 1000 = AN8
- 1001 = AN9
- 1010 = AN10
- 1011 = AN11
- 1100 = Reserved
- 1101 = Reserved
- 1110 = DAC<sup>(2)</sup>
- 1111 = FVR<sup>(2)</sup>

bit 1      **GO/DONE:** A/D Conversion Status bit

- 1 = A/D conversion cycle in progress. Setting this bit starts an A/D conversion cycle.  
This bit is automatically cleared by hardware when the A/D conversion has completed.
- 0 = A/D conversion completed/not in progress

bit 0      **ADON:** ADC Enable bit

- 1 = ADC is enabled
- 0 = ADC is disabled and consumes no operating current

- Note 1:** Selecting reserved channels will yield unpredictable results as unimplemented input channels are left floating.
- 2:** See [Section 20.0 "VOLTAGE REFERENCES"](#) for more information.

# PIC18(L)F1XK22

## REGISTER 16-2: ADCON1: A/D CONTROL REGISTER 1

U-0	U-0	U-0	U-0	R/W-0	R/W-0	R/W-0	R/W-0
—	—	—	—	PVCFG1	PVCFG0	NVCFG1	NVCFG0
bit 7							bit 0

### Legend:

R = Readable bit

W = Writable bit

U = Unimplemented bit, read as '0'

-n = Value at POR

'1' = Bit is set

'0' = Bit is cleared

x = Bit is unknown

bit 7-4      **Unimplemented:** Read as '0'

bit 3-2      **PVCFG<1:0>:** Positive Voltage Reference select bit

00 = Positive voltage reference supplied internally by VDD.

01 = Positive voltage reference supplied externally through VREF+ pin.

10 = Positive voltage reference supplied internally through FVR.

11 = Reserved.

bit 1-0      **NVCFG<1:0>:** Negative Voltage Reference select bit

00 = Positive voltage reference supplied internally by VSS.

01 = Positive voltage reference supplied externally through VREF- pin.

10 = Reserved.

11 = Reserved.

## REGISTER 16-3: ADCON2: A/D CONTROL REGISTER 2

R/W-0	U-0	R/W-0	R/W-0	R/W-0	R/W-0	R/W-0	R/W-0
ADFM	—	ACQT2	ACQT1	ACQT0	ADCS2	ADCS1	ADCS0
bit 7							bit 0

### Legend:

R = Readable bit

W = Writable bit

U = Unimplemented bit, read as '0'

-n = Value at POR

'1' = Bit is set

'0' = Bit is cleared

x = Bit is unknown

bit 7 **ADFM:** A/D Conversion Result Format Select bit

1 = Right justified

0 = Left justified

bit 6 **Unimplemented:** Read as '0'

bit 5-3 **ACQT<2:0>:** A/D Acquisition Time Select bits. Acquisition time is the duration that the A/D charge holding capacitor remains connected to A/D channel from the instant the  $\overline{GO/DONE}$  bit is set until conversions begins.

000 = 0<sup>(1)</sup>

001 = 2 TAD

010 = 4 TAD

011 = 6 TAD

100 = 8 TAD

101 = 12 TAD

110 = 16 TAD

111 = 20 TAD

bit 2-0 **ADCS<2:0>:** A/D Conversion Clock Select bits

000 = Fosc/2

001 = Fosc/8

010 = Fosc/32

011 = FRC<sup>(1)</sup> (clock derived from a dedicated internal oscillator = 600 kHz nominal)

100 = Fosc/4

101 = Fosc/16

110 = Fosc/64

111 = FRC<sup>(1)</sup> (clock derived from a dedicated internal oscillator = 600 kHz nominal)

**Note 1:** When the A/D clock source is selected as FRC then the start of conversion is delayed by one instruction cycle after the  $\overline{GO/DONE}$  bit is set to allow the `SLEEP` instruction to be executed.

# PIC18(L)F1XK22

## REGISTER 16-4: ADRESH: ADC RESULT REGISTER HIGH (ADRESH) ADFM = 0

R/W-x	R/W-x	R/W-x	R/W-x	R/W-x	R/W-x	R/W-x	R/W-x
ADRES9	ADRES8	ADRES7	ADRES6	ADRES5	ADRES4	ADRES3	ADRES2
bit 7							bit 0

**Legend:**

R = Readable bit                      W = Writable bit                      U = Unimplemented bit, read as '0'  
 -n = Value at POR                      '1' = Bit is set                      '0' = Bit is cleared                      x = Bit is unknown

bit 7-0                      **ADRES<9:2>**: ADC Result Register bits  
 Upper 8 bits of 10-bit conversion result

## REGISTER 16-5: ADRESL: ADC RESULT REGISTER LOW (ADRESL) ADFM = 0

R/W-x	R/W-x	R/W-x	R/W-x	R/W-x	R/W-x	R/W-x	R/W-x
ADRES1	ADRES0	—	—	—	—	—	—
bit 7							bit 0

**Legend:**

R = Readable bit                      W = Writable bit                      U = Unimplemented bit, read as '0'  
 -n = Value at POR                      '1' = Bit is set                      '0' = Bit is cleared                      x = Bit is unknown

bit 7-6                      **ADRES<1:0>**: ADC Result Register bits  
 Lower 2 bits of 10-bit conversion result

bit 5-0                      **Reserved**: Do not use.

## REGISTER 16-6: ADRESH: ADC RESULT REGISTER HIGH (ADRESH) ADFM = 1

R/W-x	R/W-x	R/W-x	R/W-x	R/W-x	R/W-x	R/W-x	R/W-x
—	—	—	—	—	—	ADRES9	ADRES8
bit 7						bit 0	

**Legend:**

R = Readable bit                      W = Writable bit                      U = Unimplemented bit, read as '0'  
 -n = Value at POR                      '1' = Bit is set                      '0' = Bit is cleared                      x = Bit is unknown

bit 7-2                      **Reserved**: Do not use.

bit 1-0                      **ADRES<9:8>**: ADC Result Register bits  
 Upper 2 bits of 10-bit conversion result

## REGISTER 16-7: ADRESL: ADC RESULT REGISTER LOW (ADRESL) ADFM = 1

R/W-x	R/W-x	R/W-x	R/W-x	R/W-x	R/W-x	R/W-x	R/W-x
ADRES7	ADRES6	ADRES5	ADRES4	ADRES3	ADRES2	ADRES1	ADRES0
bit 7							bit 0

**Legend:**

R = Readable bit                      W = Writable bit                      U = Unimplemented bit, read as '0'  
 -n = Value at POR                      '1' = Bit is set                      '0' = Bit is cleared                      x = Bit is unknown

bit 7-0                      **ADRES<7:0>**: ADC Result Register bits  
 Lower 8 bits of 10-bit conversion result

## 16.3 A/D Acquisition Requirements

For the ADC to meet its specified accuracy, the charge holding capacitor (CHOLD) must be allowed to fully charge to the input channel voltage level. The Analog Input model is shown in Figure 16-5. The source impedance (RS) and the internal sampling switch (RSS) impedance directly affect the time required to charge the capacitor CHOLD. The sampling switch (RSS) impedance varies over the device voltage (VDD), see Figure 16-5. **The maximum recommended impedance for analog sources is 10 kΩ.** As the source impedance is decreased, the acquisition time may be decreased. After the analog input channel is selected (or changed),

an A/D acquisition must be done before the conversion can be started. To calculate the minimum acquisition time, Equation 16-1 may be used. This equation assumes that 1/2 LSB error is used (1024 steps for the ADC). The 1/2 LSB error is the maximum error allowed for the ADC to meet its specified resolution.

### EQUATION 16-1: ACQUISITION TIME EXAMPLE

*Assumptions: Temperature = 50°C and external impedance of 10kΩ 3.0V VDD*

$$\begin{aligned} T_{ACQ} &= \text{Amplifier Settling Time} + \text{Hold Capacitor Charging Time} + \text{Temperature Coefficient} \\ &= T_{AMP} + T_C + T_{COFF} \\ &= 5\mu s + T_C + [(Temperature - 25^\circ C)(0.05\mu s/^\circ C)] \end{aligned}$$

*The value for TC can be approximated with the following equations:*

$$V_{APPLIED} \left( 1 - \frac{1}{2047} \right) = V_{CHOLD} \quad ;[1] \text{ } V_{CHOLD} \text{ charged to within } 1/2 \text{ lsb}$$

$$V_{APPLIED} \left( 1 - e^{-\frac{T_C}{RC}} \right) = V_{CHOLD} \quad ;[2] \text{ } V_{CHOLD} \text{ charge response to } V_{APPLIED}$$

$$V_{APPLIED} \left( 1 - e^{-\frac{T_C}{RC}} \right) = V_{APPLIED} \left( 1 - \frac{1}{2047} \right) \quad ;\text{combining [1] and [2]}$$

*Solving for TC:*

$$\begin{aligned} T_C &= -CHOLD(RIC + RSS + RS) \ln(1/2047) \\ &= -13.5pF(1k\Omega + 700\Omega + 10k\Omega) \ln(0.0004885) \\ &= 1.20\mu s \end{aligned}$$

*Therefore:*

$$\begin{aligned} T_{ACQ} &= 5\mu s + 1.20\mu s + [(50^\circ C - 25^\circ C)(0.05\mu s/^\circ C)] \\ &= 7.45\mu s \end{aligned}$$

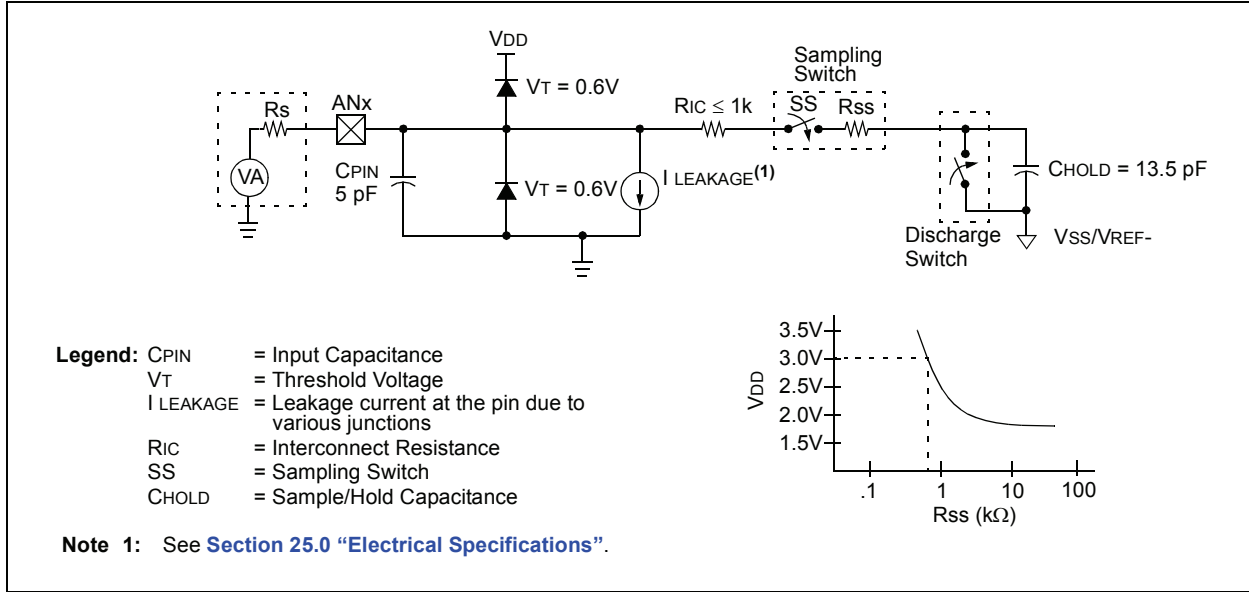
**Note 1:** The reference voltage (VREF) has no effect on the equation, since it cancels itself out.

**2:** The charge holding capacitor (CHOLD) is discharged after each conversion.

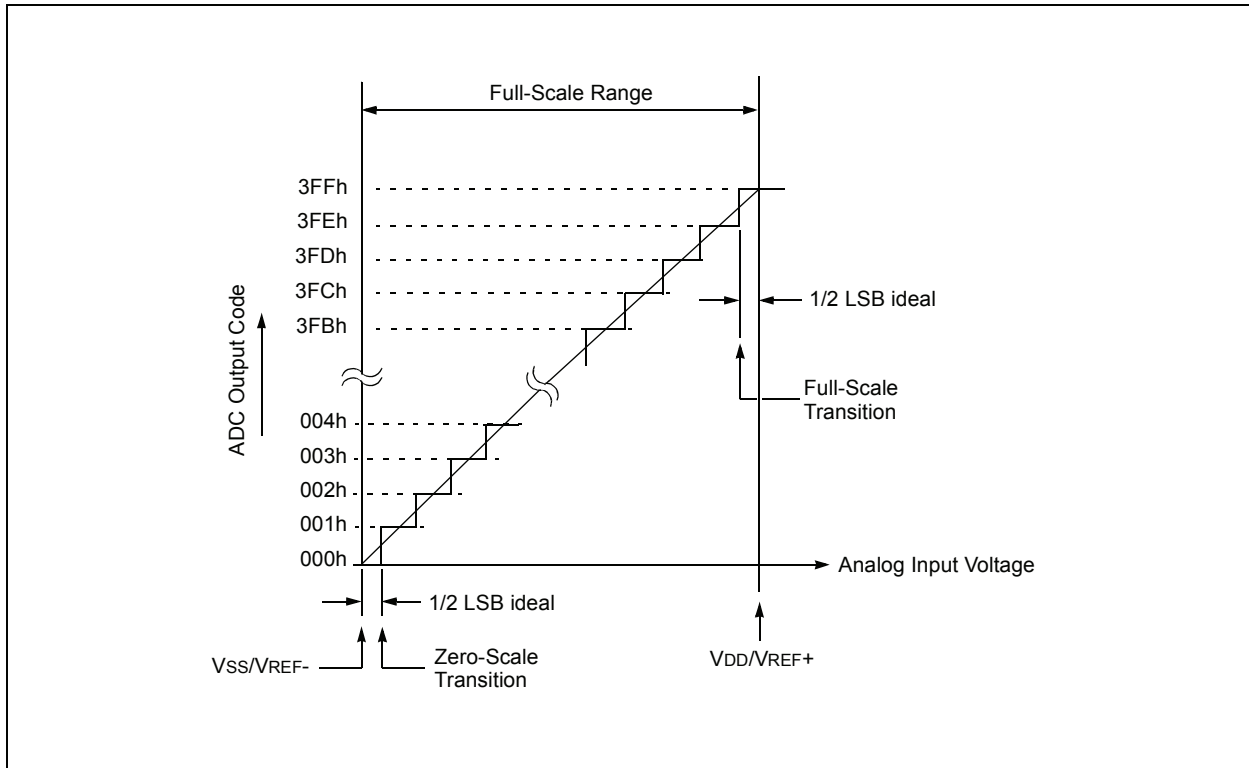
**3:** The maximum recommended impedance for analog sources is 10 kΩ. This is required to meet the pin leakage specification.

# PIC18(L)F1XK22

**FIGURE 16-5: ANALOG INPUT MODEL**



**FIGURE 16-6: ADC TRANSFER FUNCTION**



**TABLE 16-2: REGISTERS ASSOCIATED WITH A/D OPERATION**

Name	Bit 7	Bit 6	Bit 5	Bit 4	Bit 3	Bit 2	Bit 1	Bit 0	Reset Values on page
ADRESH	A/D Result Register, High Byte								255
ADRESL	A/D Result Register, Low Byte								255
ADCON0	—	—	CHS3	CHS2	CHS1	CHS0	GO/DONE	ADON	255
ADCON1	—	—	—	—	PVCFG1	PVCFG0	NVCFG1	NVCFG0	255
ADCON2	ADFM	—	ACQT2	ACQT1	ACQT0	ADCS2	ADCS1	ADCS0	255
ANSEL	ANS7	ANS6	ANS5	ANS4	ANS3	ANS2	ANS1	ANS0	256
ANSELH	—	—	—	—	ANS11	ANS10	ANS9	ANS8	256
INTCON	GIE/GIEH	PEIE/GIEL	TMR0IE	INT0IE	RABIE	TMR0IF	INT0IF	RABIF	253
IPR1	—	ADIP	RCIP	TXIP	SSPIP	CCP1IP	TMR2IP	TMR1IP	256
PIE1	—	ADIE	RCIE	TXIE	SSPIE	CCP1IE	TMR2IE	TMR1IE	256
PIR1	—	ADIF	RCIF	TXIF	SSPIF	CCP1IF	TMR2IF	TMR1IF	256
TRISA	—	—	TRISA5	TRISA4	—	TRISA2	TRISA1	TRISA0	256
TRISB	TRISB7	TRISB6	TRISB5	TRISB4	—	—	—	—	256
TRISC	TRISC7	TRISC6	TRISC5	TRISC4	TRISC3	TRISC2	TRISC1	TRISC0	256

**Legend:** — = unimplemented, read as '0'. Shaded cells are not used for A/D conversion.

# PIC18(L)F1XK22

---

NOTES:



## 17.0 COMPARATOR MODULE

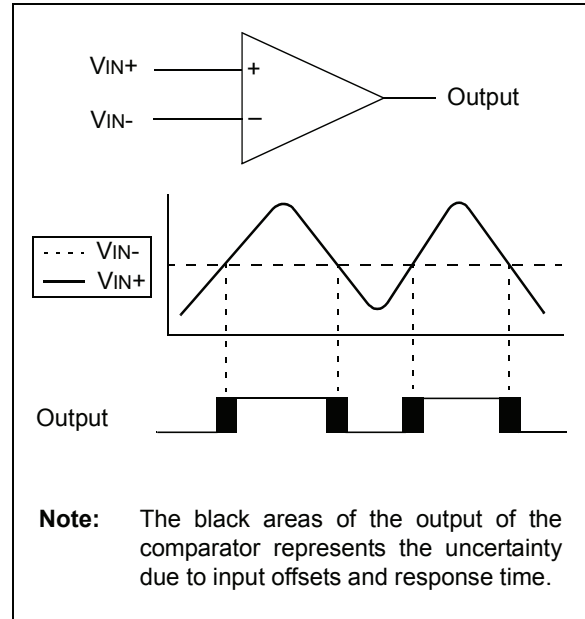
Comparators are used to interface analog circuits to a digital circuit by comparing two analog voltages and providing a digital indication of their relative magnitudes. The comparators are very useful mixed signal building blocks because they provide analog functionality independent of the program execution. The Analog Comparator module includes the following features:

- Independent comparator control
- Programmable input selection
- Comparator output is available internally/externally
- Programmable output polarity
- Interrupt-on-change
- Wake-up from Sleep
- Programmable Speed/Power optimization
- PWM shutdown
- Programmable and fixed voltage reference

### 17.1 Comparator Overview

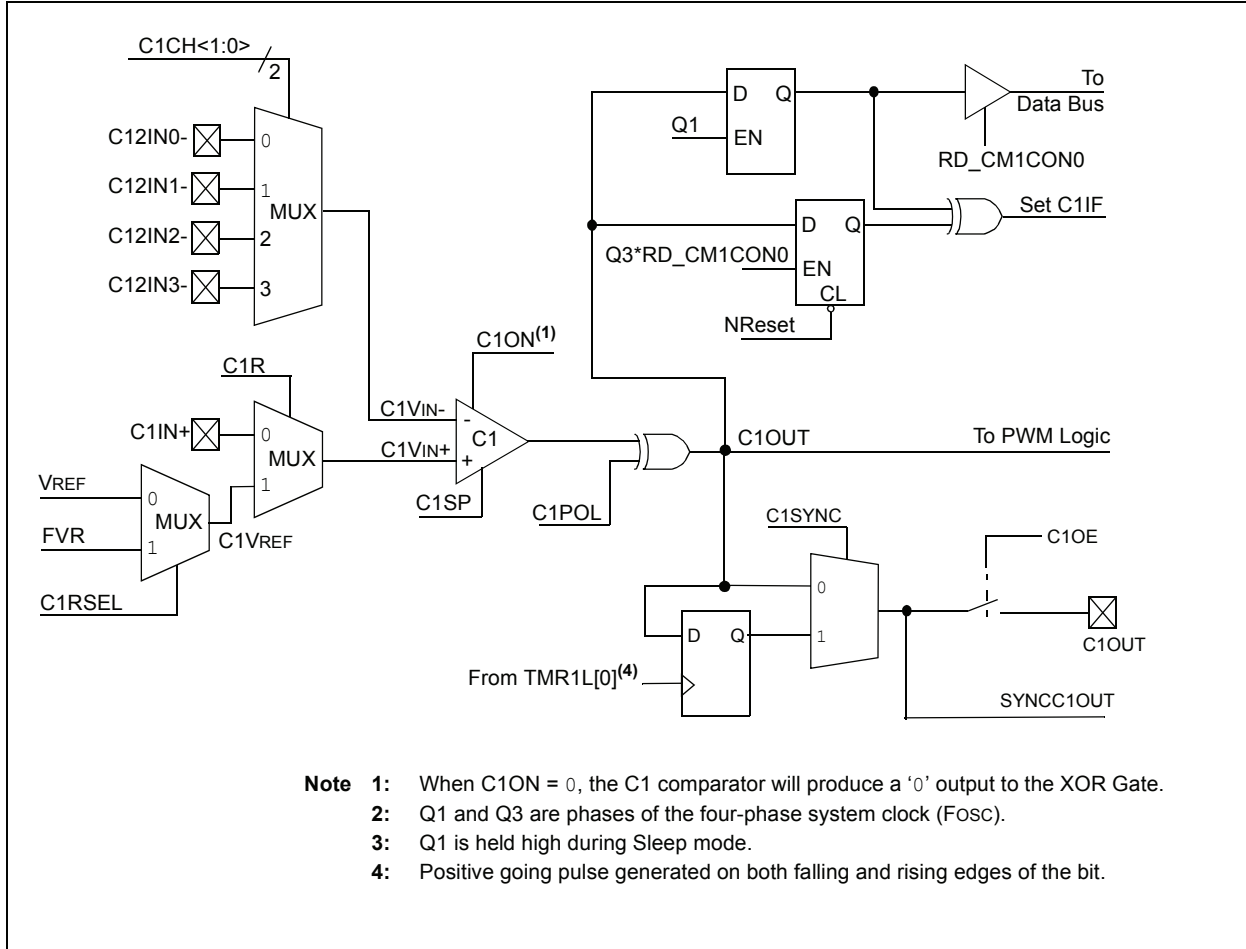
A single comparator is shown in [Figure 17-1](#) along with the relationship between the analog input levels and the digital output. When the analog voltage at  $V_{IN+}$  is less than the analog voltage at  $V_{IN-}$ , the output of the comparator is a digital low level. When the analog voltage at  $V_{IN+}$  is greater than the analog voltage at  $V_{IN-}$ , the output of the comparator is a digital high level.

FIGURE 17-1: SINGLE COMPARATOR

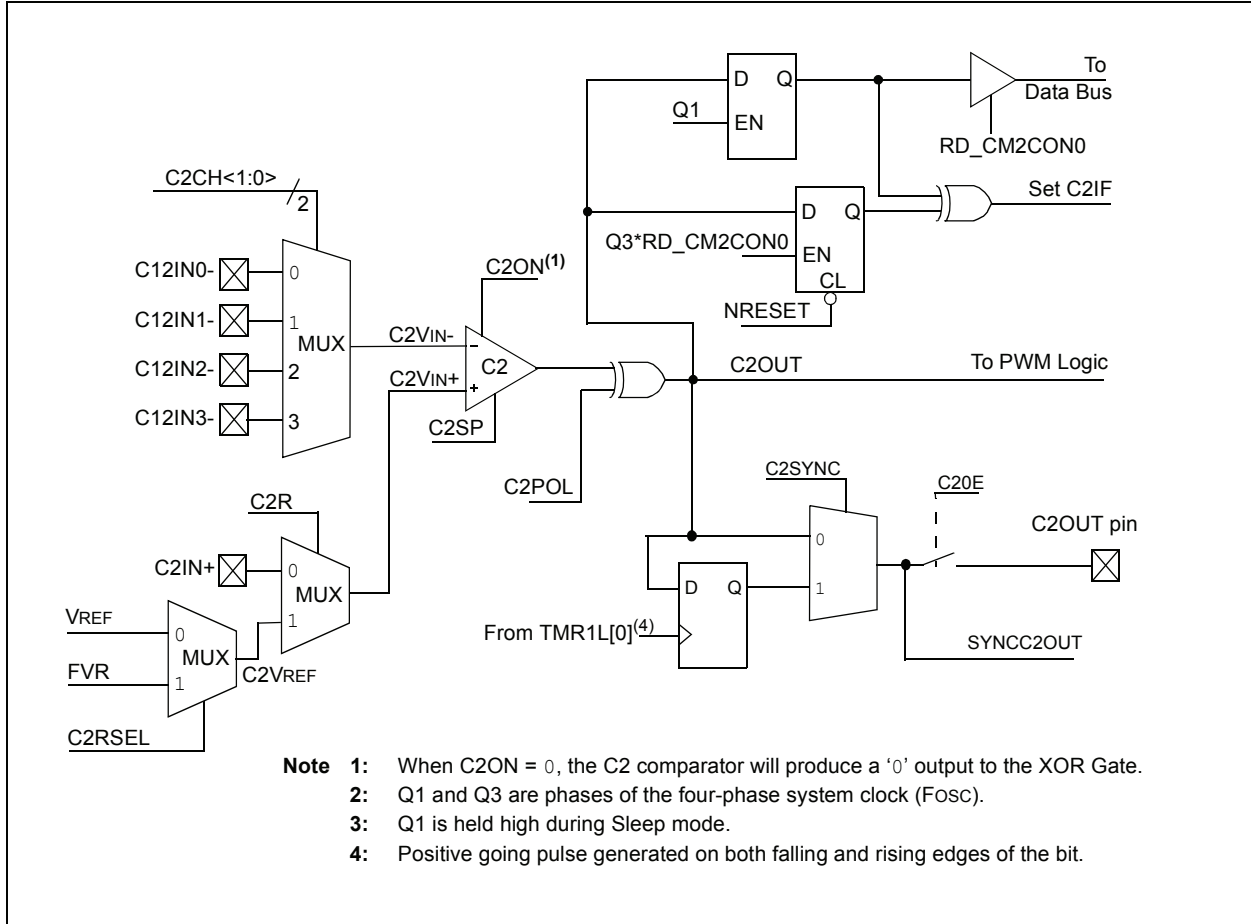


# PIC18(L)F1XK22

FIGURE 17-2: COMPARATOR C1 SIMPLIFIED BLOCK DIAGRAM



**FIGURE 17-3: COMPARATOR C2 SIMPLIFIED BLOCK DIAGRAM**



# PIC18(L)F1XK22

## 17.2 Comparator Control

Each comparator has a separate control and Configuration register: CM1CON0 for Comparator C1 and CM2CON0 for Comparator C2. In addition, Comparator C2 has a second control register, CM2CON1, for controlling the interaction with Timer1 and simultaneous reading of both comparator outputs.

The CM1CON0 and CM2CON0 registers (see Registers 17-1 and 17-2, respectively) contain the control and status bits for the following:

- Enable
- Input selection
- Reference selection
- Output selection
- Output polarity
- Speed selection

### 17.2.1 COMPARATOR ENABLE

Setting the CxON bit of the CMxCON0 register enables the comparator for operation. Clearing the CxON bit disables the comparator resulting in minimum current consumption.

### 17.2.2 COMPARATOR INPUT SELECTION

The CxCH<1:0> bits of the CMxCON0 register direct one of four analog input pins to the comparator inverting input.

**Note:** To use CxIN+ and C12INx- pins as analog inputs, the appropriate bits must be set in the ANSEL register and the corresponding TRIS bits must also be set to disable the output drivers.

### 17.2.3 COMPARATOR REFERENCE SELECTION

Setting the CxR bit of the CMxCON0 register directs an internal voltage reference or an analog input pin to the non-inverting input of the comparator. See [Section 20.0 “VOLTAGE REFERENCES”](#) for more information on the Internal Voltage Reference module.

### 17.2.4 COMPARATOR OUTPUT SELECTION

The output of the comparator can be monitored by reading either the CxOUT bit of the CMxCON0 register or the MCxOUT bit of the CM2CON1 register. In order to make the output available for an external connection, the following conditions must be true:

- CxOE bit of the CMxCON0 register must be set
- Corresponding TRIS bit must be cleared
- CxON bit of the CMxCON0 register must be set

**Note 1:** The CxOE bit overrides the PORT data latch. Setting the CxON has no impact on the port override.

**2:** The internal output of the comparator is latched with each instruction cycle. Unless otherwise specified, external outputs are not latched.

### 17.2.5 COMPARATOR OUTPUT POLARITY

Inverting the output of the comparator is functionally equivalent to swapping the comparator inputs. The polarity of the comparator output can be inverted by setting the CxPOL bit of the CMxCON0 register. Clearing the CxPOL bit results in a non-inverted output.

[Table 17-1](#) shows the output state versus input conditions, including polarity control.

**TABLE 17-1: COMPARATOR OUTPUT STATE VS. INPUT CONDITIONS**

Input Condition	CxPOL	CxOUT
CxVIN- > CxVIN+	0	0
CxVIN- < CxVIN+	0	1
CxVIN- > CxVIN+	1	1
CxVIN- < CxVIN+	1	0

### 17.2.6 COMPARATOR SPEED SELECTION

The trade-off between speed or power can be optimized during program execution with the CxSP control bit. The default state for this bit is '1' which selects the normal speed mode. Device power consumption can be optimized at the cost of slower comparator propagation delay by clearing the CxSP bit to '0'.

## 17.3 Comparator Response Time

The comparator output is indeterminate for a period of time after the change of an input source or the selection of a new reference voltage. This period is referred to as the response time. The response time of the comparator differs from the settling time of the voltage reference. Therefore, both of these times must be considered when determining the total response time to a comparator input change. See the Comparator and Voltage Reference Specifications in [Section 25.0 “Electrical Specifications”](#) for more details.

## 17.4 Comparator Interrupt Operation

The comparator interrupt flag can be set whenever there is a change in the output value of the comparator. Changes are recognized by means of a mismatch circuit which consists of two latches and an exclusive-or gate (see Figure 17-2 and Figure 17-3). One latch is updated with the comparator output level when the CMxCON0 register is read. This latch retains the value until the next read of the CMxCON0 register or the occurrence of a Reset. The other latch of the mismatch circuit is updated on every Q1 system clock. A mismatch condition will occur when a comparator output change is clocked through the second latch on the Q1 clock cycle. At this point the two mismatch latches have opposite output levels which is detected by the exclusive-or gate and fed to the interrupt circuitry. The mismatch condition persists until either the CMxCON0 register is read or the comparator output returns to the previous state.

**Note 1:** A write operation to the CMxCON0 register will also clear the mismatch condition because all writes include a read operation at the beginning of the write cycle.

**2:** Comparator interrupts will operate correctly regardless of the state of CxOE.

The comparator interrupt is set by the mismatch edge and not the mismatch level. This means that the interrupt flag can be reset without the additional step of reading or writing the CMxCON0 register to clear the mismatch registers. When the mismatch registers are cleared, an interrupt will occur upon the comparator's return to the previous state, otherwise no interrupt will be generated.

Software will need to maintain information about the status of the comparator output, as read from the CMxCON0 register, or CM2CON1 register, to determine the actual change that has occurred. See Figures 17-4 and 17-5.

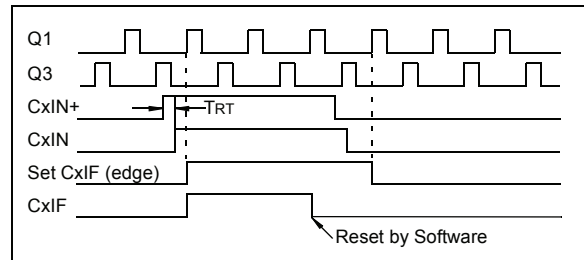
The CxIF bit of the PIR2 register is the comparator interrupt flag. This bit must be reset by software by clearing it to '0'. Since it is also possible to write a '1' to this register, an interrupt can be generated.

In mid-range Compatibility mode the CxIE bit of the PIE2 register and the PEIE and GIE bits of the INTCON register must all be set to enable comparator interrupts. If any of these bits are cleared, the interrupt is not enabled, although the CxIF bit of the PIR2 register will still be set if an interrupt condition occurs.

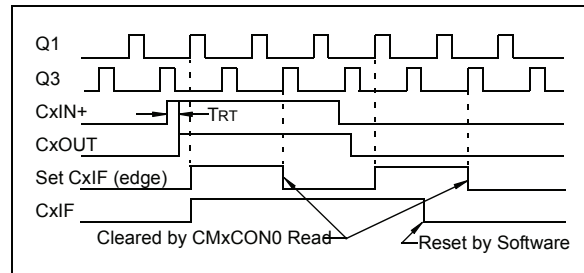
### 17.4.1 PRESETTING THE MISMATCH LATCHES

The comparator mismatch latches can be preset to the desired state before the comparators are enabled. When the comparator is off the CxPOL bit controls the CxOUT level. Set the CxPOL bit to the desired CxOUT non-interrupt level while the CxON bit is cleared. Then, configure the desired CxPOL level in the same instruction that the CxON bit is set. Since all register writes are performed as a Read-Modify-Write, the mismatch latches will be cleared during the instruction Read phase and the actual configuration of the CxON and CxPOL bits will occur in the final Write phase.

**FIGURE 17-4: COMPARATOR INTERRUPT TIMING W/O CMxCON0 READ**



**FIGURE 17-5: COMPARATOR INTERRUPT TIMING WITH CMxCON0 READ**



**Note 1:** If a change in the CMxCON0 register (CxOUT) should occur when a read operation is being executed (start of the Q2 cycle), then the CxIF interrupt flag of the PIR2 register may not get set.

**2:** When either comparator is first enabled, bias circuitry in the comparator module may cause an invalid output from the comparator until the bias circuitry is stable. Allow about 1  $\mu$ s for bias settling then clear the mismatch condition and interrupt flags before enabling comparator interrupts.

## 17.5 Operation During Sleep

The comparator, if enabled before entering Sleep mode, remains active during Sleep. The additional current consumed by the comparator is shown separately in [Section 25.0 “Electrical Specifications”](#). If the comparator is not used to wake the device, power consumption can be minimized while in Sleep mode by turning off the comparator. Each comparator is turned off by clearing the CxON bit of the CMxCON0 register.

A change to the comparator output can wake-up the device from Sleep. To enable the comparator to wake the device from Sleep, the CxIE bit of the PIE2 register and the PEIE bit of the INTCON register must be set. The instruction following the `SLEEP` instruction always executes following a wake from Sleep. If the GIE bit of the INTCON register is also set, the device will then execute the Interrupt Service Routine.

## 17.6 Effects of a Reset

A device Reset forces the CMxCON0 and CM2CON1 registers to their Reset states. This forces both comparators and the voltage references to their Off states.

## REGISTER 17-1: CM1CON0: COMPARATOR 1 CONTROL REGISTER 0

R/W-0	R-0	R/W-0	R/W-0	R/W-0	R/W-0	R/W-0	R/W-0
C1ON	C1OUT	C1OE	C1POL	C1SP	C1R	C1CH1	C1CH0
bit 7							bit 0

### Legend:

R = Readable bit	W = Writable bit	U = Unimplemented bit, read as '0'
-n = Value at POR	'1' = Bit is set	'0' = Bit is cleared
		x = Bit is unknown

- bit 7      **C1ON:** Comparator C1 Enable bit  
 1 = Comparator C1 is enabled  
 0 = Comparator C1 is disabled
- bit 6      **C1OUT:** Comparator C1 Output bit  
If C1POL = 1 (inverted polarity):  
 C1OUT = 0 when C1VIN+ > C1VIN-  
 C1OUT = 1 when C1VIN+ < C1VIN-  
If C1POL = 0 (non-inverted polarity):  
 C1OUT = 1 when C1VIN+ > C1VIN-  
 C1OUT = 0 when C1VIN+ < C1VIN-
- bit 5      **C1OE:** Comparator C1 Output Enable bit  
 1 = C1OUT is present on the C1OUT pin<sup>(1)</sup>  
 0 = C1OUT is internal only
- bit 4      **C1POL:** Comparator C1 Output Polarity Select bit  
 1 = C1OUT logic is inverted  
 0 = C1OUT logic is not inverted
- bit 3      **C1SP:** Comparator C1 Speed/Power Select bit  
 1 = C1 operates in normal power, higher speed mode  
 0 = C1 operates in low-power, low-speed mode
- bit 2      **C1R:** Comparator C1 Reference Select bit (non-inverting input)  
 1 = C1VIN+ connects to C1VREF output  
 0 = C1VIN+ connects to C12IN+ pin
- bit 1-0    **C1CH<1:0>:** Comparator C1 Channel Select bit  
 00 = C12IN0- pin of C1 connects to C1VIN-  
 01 = C12IN1- pin of C1 connects to C1VIN-  
 10 = C12IN2- pin of C1 connects to C1VIN-  
 11 = C12IN3- pin of C1 connects to C1VIN-

**Note 1:** Comparator output requires the following three conditions: C1OE = 1, C1ON = 1 and corresponding port TRIS bit = 0.

# PIC18(L)F1XK22

## REGISTER 17-2: CM2CON0: COMPARATOR 2 CONTROL REGISTER 0

R/W-0	R-0	R/W-0	R/W-0	R/W-0	R/W-0	R/W-0	R/W-0
C2ON	C2OUT	C2OE	C2POL	C2SP	C2R	C2CH1	C2CH0
bit 7							bit 0

### Legend:

R = Readable bit

W = Writable bit

U = Unimplemented bit, read as '0'

-n = Value at POR

'1' = Bit is set

'0' = Bit is cleared

x = Bit is unknown

- bit 7      **C2ON:** Comparator C2 Enable bit  
1 = Comparator C2 is enabled  
0 = Comparator C2 is disabled
- bit 6      **C2OUT:** Comparator C2 Output bit  
If C2POL = 1 (inverted polarity):  
C2OUT = 0 when C2VIN+ > C2VIN-  
C2OUT = 1 when C2VIN+ < C2VIN-  
If C2POL = 0 (non-inverted polarity):  
C2OUT = 1 when C2VIN+ > C2VIN-  
C2OUT = 0 when C2VIN+ < C2VIN-
- bit 5      **C2OE:** Comparator C2 Output Enable bit  
1 = C2OUT is present on C2OUT pin<sup>(1)</sup>  
0 = C2OUT is internal only
- bit 4      **C2POL:** Comparator C2 Output Polarity Select bit  
1 = C2OUT logic is inverted  
0 = C2OUT logic is not inverted
- bit 3      **C2SP:** Comparator C2 Speed/Power Select bit  
1 = C2 operates in normal power, higher speed mode  
0 = C2 operates in low-power, low-speed mode
- bit 2      **C2R:** Comparator C2 Reference Select bits (non-inverting input)  
1 = C2VIN+ connects to C2VREF  
0 = C2VIN+ connects to C2IN+ pin
- bit 1-0    **C2CH<1:0>:** Comparator C2 Channel Select bits  
00 = C12IN0- pin of C2 connects to C2VIN-  
01 = C12IN1- pin of C2 connects to C2VIN-  
10 = C12IN2- pin of C2 connects to C2VIN-  
11 = C12IN3- pin of C2 connects to C2VIN-

**Note 1:** Comparator output requires the following three conditions: C2OE = 1, C2ON = 1 and corresponding port TRIS bit = 0.



## 17.7 Analog Input Connection Considerations

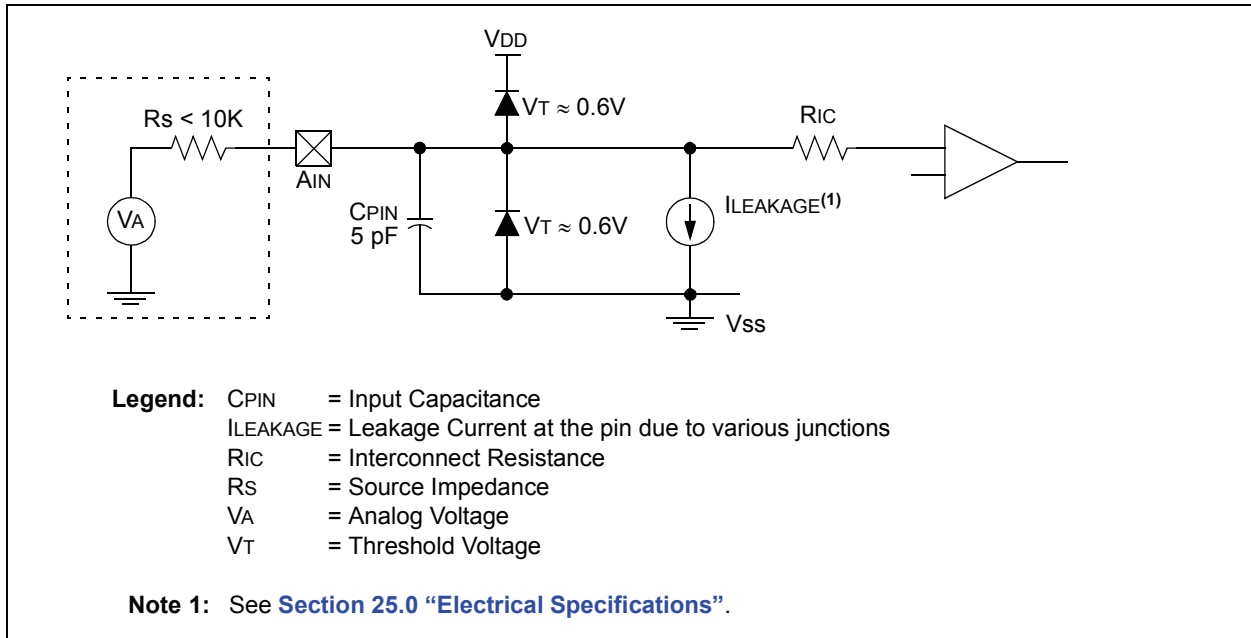
A simplified circuit for an analog input is shown in Figure 17-6. Since the analog input pins share their connection with a digital input, they have reverse biased ESD protection diodes to VDD and VSS. The analog input, therefore, must be between VSS and VDD. If the input voltage deviates from this range by more than 0.6V in either direction, one of the diodes is forward biased and a latch-up may occur.

A maximum source impedance of 10 kΩ is recommended for the analog sources. Also, any external component connected to an analog input pin, such as a capacitor or a Zener diode, should have very little leakage current to minimize inaccuracies introduced.

**Note 1:** When reading a PORT register, all pins configured as analog inputs will read as a '0'. Pins configured as digital inputs will convert as an analog input, according to the input specification.

**2:** Analog levels on any pin defined as a digital input, may cause the input buffer to consume more current than is specified.

**FIGURE 17-6: ANALOG INPUT MODEL**



# PIC18(L)F1XK22

---

## 17.8 Additional Comparator Features

There are four additional comparator features:

- Simultaneous read of comparator outputs
- Internal reference selection
- Hysteresis selection
- Output Synchronization

### 17.8.1 SIMULTANEOUS COMPARATOR OUTPUT READ

The MC1OUT and MC2OUT bits of the CM2CON1 register are mirror copies of both comparator outputs. The ability to read both outputs simultaneously from a single register eliminates the timing skew of reading separate registers.

**Note 1:** Obtaining the status of C1OUT or C2OUT by reading CM2CON1 does not affect the comparator interrupt mismatch registers.

### 17.8.2 INTERNAL REFERENCE SELECTION

There are two internal voltage references available to the non-inverting input of each comparator. One of these is the Fixed Voltage Reference (FVR) and the other is the variable Comparator Voltage Reference (CVREF). The CxRSEL bit of the CM2CON register determines which of these references is routed to the Comparator Voltage reference output (CxVREF). Further routing to the comparator is accomplished by the CxR bit of the CMxCON0 register. See [Section 20.1 “Voltage Reference”](#) and [Figure 17-2](#) and [Figure 17-3](#) for more detail.

### 17.8.3 COMPARATOR HYSTERESIS

The Comparator Cx have selectable hysteresis. The hysteresis can be enabled by setting the CxHYS bit of the CM2CON1 register. See [Section 25.0 “Electrical Specifications”](#) for more details.

### 17.8.4 SYNCHRONIZING COMPARATOR OUTPUT TO TIMER 1

The Comparator Cx output can be synchronized with Timer1 by setting the CxSYNC bit of the CM2CON1 register. When enabled, the Cx output is latched on the rising edge of the Timer1 source clock. If a prescaler is used with Timer1, the comparator output is latched after the prescaling function. To prevent a race condition, the comparator output is latched on the rising edge of the Timer1 clock source and Timer1 increments on the rising edge of its clock source. See the Comparator Block Diagram ([Figure 17-2](#) and [Figure 17-3](#)) and the Timer1 Block Diagram ([Figure 17-2](#)) for more information.

## REGISTER 17-3: CM2CON1: COMPARATOR 2 CONTROL REGISTER 1

R-0	R-0	R/W-0	R/W-0	R/W-0	R/W-0	R/W-0	R/W-0
MC1OUT	MC2OUT	C1RSEL	C2RSEL	C1HYS	C2HYS	C1SYNC	C2SYNC
bit 7							bit 0

### Legend:

R = Readable bit	W = Writable bit	U = Unimplemented bit, read as '0'
-n = Value at POR	'1' = Bit is set	'0' = Bit is cleared      x = Bit is unknown

- bit 7      **MC1OUT:** Mirror Copy of C1OUT bit
- bit 6      **MC2OUT:** Mirror Copy of C2OUT bit
- bit 5      **C1RSEL:** Comparator C1 Reference Select bit  
             1 = FVR routed to C1VREF input  
             0 = CVREF routed to C1VREF input
- bit 4      **C2RSEL:** Comparator C2 Reference Select bit  
             1 = FVR routed to C2VREF input  
             0 = CVREF routed to C2VREF input
- bit 3      **C1HYS:** Comparator C1 Hysteresis Enable bit  
             1 = Comparator C1 hysteresis enabled  
             0 = Comparator C1 hysteresis disabled
- bit 2      **C2HYS:** Comparator C2 Hysteresis Enable bit  
             1 = Comparator C2 hysteresis enabled  
             0 = Comparator C2 hysteresis disabled
- bit 1      **C1SYNC:** C1 Output Synchronous Mode bit  
             1 = C1 output is synchronous to rising edge to TMR1 clock  
             0 = C1 output is asynchronous
- bit 0      **C2SYNC:** C2 Output Synchronous Mode bit  
             1 = C2 output is synchronous to rising edge to TMR1 clock  
             0 = C2 output is asynchronous

# PIC18(L)F1XK22

**TABLE 17-2: REGISTERS ASSOCIATED WITH COMPARATOR MODULE**

Name	Bit 7	Bit 6	Bit 5	Bit 4	Bit 3	Bit 2	Bit 1	Bit 0	Reset Values on page
ANSEL	ANS7	ANS6	ANS5	ANS4	ANS3	ANS2	ANS1	ANS0	256
CM1CON0	C1ON	C1OUT	C1OE	C1POL	C1SP	C1R	C1CH1	C1CH0	256
CM2CON0	C2ON	C2OUT	C2OE	C2POL	C2SP	C2R	C2CH1	C2CH0	256
CM2CON1	MC1OUT	MC2OUT	C1RSEL	C2RSEL	C1HYS	C2HYS	C1SYNC	C2SYNC	256
INTCON	GIE/GIEH	PEIE/GIEL	TMR0IE	INT0IE	RABIE	TMR0IF	INT0IF	RABIF	253
IPR2	OSCFIP	C1IP	C2IP	EEIP	BCLIP	—	TMR3IP	—	256
LATC	LATC7	LATC6	LATC5	LATC4	LATC3	LATC2	LATC1	LATC0	256
PIE2	OSCFIE	C1IE	C2IE	EEIE	BCLIE	—	TMR3IE	—	256
PIR2	OSCFIF	C1IF	C2IF	EEIF	BCLIF	—	TMR3IF	—	256
PORTC	RC7	RC6	RC5	RC4	RC3	RC2	RC1	RC0	256
VREFCON0	FVR1EN	FVR1ST	FVR1S1	FVR1S0	—	—	—	—	255
VREFCON1	D1EN	D1LPS	DAC1OE	---	D1PSS1	D1PSS0	—	D1NSS	255
TRISA	—	—	TRISA5	TRISA4	—	TRISA2	TRISA1	TRISA0	256
TRISC	TRISC7	TRISC6	TRISC5	TRISC4	TRISC3	TRISC2	TRISC1	TRISC0	256

**Legend:** — = unimplemented, read as '0'. Shaded cells are unused by the comparator module.

## 18.0 POWER-MANAGED MODES

PIC18(L)F1XK22 devices offer a total of seven operating modes for more efficient power management. These modes provide a variety of options for selective power conservation in applications where resources may be limited (i.e., battery-powered devices).

There are three categories of power-managed modes:

- Run modes
- Idle modes
- Sleep mode

These categories define which portions of the device are clocked and sometimes, what speed. The Run and Idle modes may use any of the three available clock sources (primary, secondary or internal oscillator block); the Sleep mode does not use a clock source.

The power-managed modes include several power-saving features offered on previous PIC® microcontroller devices. One is the clock switching feature which allows the controller to use the Timer1 oscillator in place of the primary oscillator. Also included is the Sleep mode, offered by all PIC® microcontroller devices, where all device clocks are stopped.

### 18.1 Selecting Power-Managed Modes

Selecting a power-managed mode requires two decisions:

- Whether or not the CPU is to be clocked
- The selection of a clock source

The IDLEN bit of the OSCCON register controls CPU clocking, while the SCS<1:0> bits of the OSCCON register select the clock source. The individual modes, bit settings, clock sources and affected modules are summarized in Table 18-1.

#### 18.1.1 CLOCK SOURCES

The SCS<1:0> bits allow the selection of one of three clock sources for power-managed modes. They are:

- the primary clock, as defined by the FOSC<3:0> Configuration bits
- the secondary clock (the Timer1 oscillator)
- the internal oscillator block

#### 18.1.2 ENTERING POWER-MANAGED MODES

Switching from one power-managed mode to another begins by loading the OSCCON register. The SCS<1:0> bits select the clock source and determine which Run or Idle mode is to be used. Changing these bits causes an immediate switch to the new clock source, assuming that it is running. The switch may also be subject to clock transition delays. Refer to [Section 2.9 “Clock Switching”](#) for more information.

Entry to the power-managed Idle or Sleep modes is triggered by the execution of a SLEEP instruction. The actual mode that results depends on the status of the IDLEN bit of the OSCCON register.

Depending on the current mode and the mode being switched to, a change to a power-managed mode does not always require setting all of these bits. Many transitions may be done by changing the oscillator select bits, or changing the IDLEN bit, prior to issuing a SLEEP instruction. If the IDLEN bit is already configured correctly, it may only be necessary to perform a SLEEP instruction to switch to the desired mode.

**TABLE 18-1: POWER-MANAGED MODES**

Mode	OSCCON Bits		Module Clocking		Available Clock and Oscillator Source
	IDLEN <sup>(1)</sup>	SCS<1:0>	CPU	Peripherals	
Sleep	0	N/A	Off	Off	None – All clocks are disabled
PRI_RUN	N/A	00	Clocked	Clocked	Primary – LP, XT, HS, RC, EC and Internal Oscillator Block <sup>(2)</sup> . This is the normal full power execution mode.
SEC_RUN	N/A	01	Clocked	Clocked	Secondary – Timer1 Oscillator
RC_RUN	N/A	1x	Clocked	Clocked	Internal Oscillator Block <sup>(2)</sup>
PRI_IDLE	1	00	Off	Clocked	Primary – LP, XT, HS, HSPLL, RC, EC
SEC_IDLE	1	01	Off	Clocked	Secondary – Timer1 Oscillator
RC_IDLE	1	1x	Off	Clocked	Internal Oscillator Block <sup>(2)</sup>

**Note 1:** IDLEN reflects its value when the SLEEP instruction is executed.

**2:** Includes HFINTOSC and HFINTOSC postscaler, as well as the LFINTOSC source.

# PIC18(L)F1XK22

---

## 18.1.3 MULTIPLE FUNCTIONS OF THE SLEEP COMMAND

The power-managed mode that is invoked with the `SLEEP` instruction is determined by the setting of the `IDLEN` bit of the `OSCCON` register at the time the instruction is executed. All clocks stop and minimum power is consumed when `SLEEP` is executed with the `IDLEN` bit cleared. The system clock continues to supply a clock to the peripherals but is disconnected from the CPU when `SLEEP` is executed with the `IDLEN` bit set.

## 18.2 Run Modes

In the Run modes, clocks to both the core and peripherals are active. The difference between these modes is the clock source.

### 18.2.1 PRI\_RUN MODE

The `PRI_RUN` mode is the normal, full power execution mode of the microcontroller. This is also the default mode upon a device Reset, unless Two-Speed Start-up is enabled (see [Section 2.11 “Two-Speed Start-up Mode”](#) for details). In this mode, the device operated off the oscillator defined by the `FOSC` bits of the `CONFIG` Configuration register.

### 18.2.2 SEC\_RUN MODE

In `SEC_RUN` mode, the CPU and peripherals are clocked from the secondary external oscillator. This gives users the option of lower power consumption while still using a high accuracy clock source.

`SEC_RUN` mode is entered by setting the `SCS<1:0>` bits of the `OSCCON` register to '01'. When `SEC_RUN` mode is active all of the following are true:

- The main clock source is switched to the secondary external oscillator
- Primary external oscillator is shut down
- `T1RUN` bit of the `T1CON` register is set
- `OSTS` bit is cleared.

**Note:** The secondary external oscillator should already be running prior to entering `SEC_RUN` mode. If the `T1OSCEN` bit is not set when the `SCS<1:0>` bits are set to '01', entry to `SEC_RUN` mode will not occur until `T1OSCEN` bit is set and secondary external oscillator is ready.

### 18.2.3 RC\_RUN MODE

In `RC_RUN` mode, the CPU and peripherals are clocked from the internal oscillator. In this mode, the primary external oscillator is shut down. `RC_RUN` mode provides the best power conservation of all the Run modes when the `LFINTOSC` is the system clock.

`RC_RUN` mode is entered by setting the `SCS1` bit. When the clock source is switched from the primary oscillator to the internal oscillator, the primary oscillator is shut down and the `OSTS` bit is cleared. The `IRCF` bits may be modified at any time to immediately change the clock speed.

## 18.3 Sleep Mode

The Power-Managed Sleep mode in the PIC18(L)F1XK22 devices is identical to the legacy Sleep mode offered in all other PIC® microcontroller devices. It is entered by clearing the IDLEN bit of the OSCCON register and executing the `SLEEP` instruction. This shuts down the selected oscillator (Figure 18-1) and all clock source status bits are cleared.

Entering the Sleep mode from either Run or Idle mode does not require a clock switch. This is because no clocks are needed once the controller has entered Sleep. If the WDT is selected, the LFINTOSC source will continue to operate. If the Timer1 oscillator is enabled, it will also continue to run.

When a wake event occurs in Sleep mode (by interrupt, Reset or WDT time-out), the device will not be clocked until the clock source selected by the SCS<1:0> bits becomes ready (see Figure 18-2), or it will be clocked from the internal oscillator block if either the Two-Speed Start-up or the Fail-Safe Clock Monitor are enabled (see Section 22.0 “Special Features of the CPU”). In either case, the OSTS bit is set when the primary clock is providing the device clocks. The IDLEN and SCS bits are not affected by the wake-up.

## 18.4 Idle Modes

The Idle modes allow the controller’s CPU to be selectively shut down while the peripherals continue to operate. Selecting a particular Idle mode allows users to further manage power consumption.

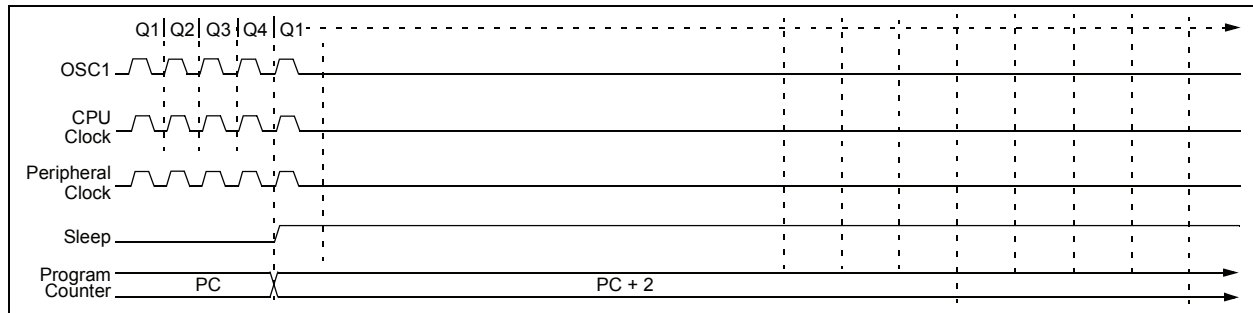
If the IDLEN bit is set to a ‘1’ when a `SLEEP` instruction is executed, the peripherals will be clocked from the clock source selected by the SCS<1:0> bits; however, the CPU will not be clocked. The clock source status bits are not affected. Setting IDLEN and executing a `SLEEP` instruction provides a quick method of switching from a given Run mode to its corresponding Idle mode.

If the WDT is selected, the LFINTOSC source will continue to operate. If the Timer1 oscillator is enabled, it will also continue to run.

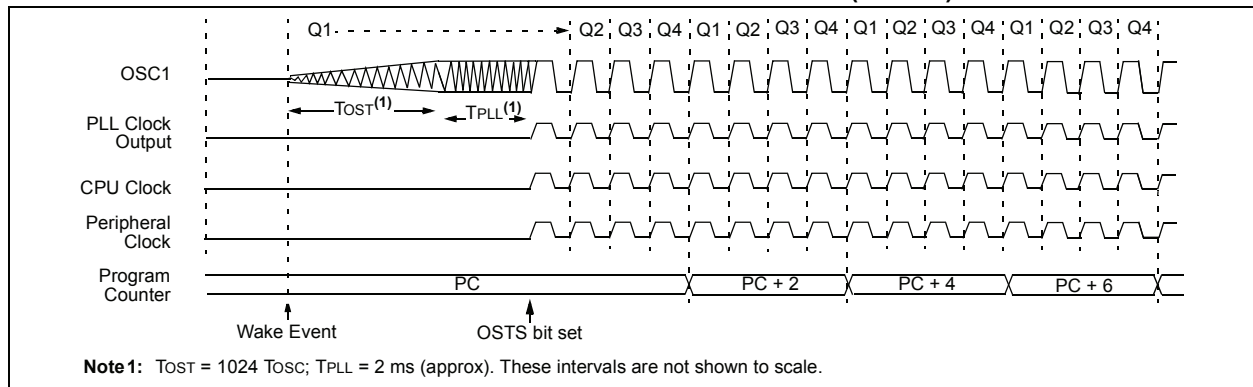
Since the CPU is not executing instructions, the only exits from any of the Idle modes are by interrupt, WDT time-out, or a Reset. When a wake event occurs, CPU execution is delayed by an interval of  $T_{CSD}$  while it becomes ready to execute code. When the CPU begins executing code, it resumes with the same clock source for the current Idle mode. For example, when waking from RC\_IDLE mode, the internal oscillator block will clock the CPU and peripherals (in other words, RC\_RUN mode). The IDLEN and SCS bits are not affected by the wake-up.

While in any Idle mode or the Sleep mode, a WDT time-out will result in a WDT wake-up to the Run mode currently specified by the SCS<1:0> bits.

**FIGURE 18-1: TRANSITION TIMING FOR ENTRY TO SLEEP MODE**



**FIGURE 18-2: TRANSITION TIMING FOR WAKE FROM SLEEP (HSPLL)**



**Note 1:**  $T_{OST} = 1024 T_{OSC}$ ;  $T_{PLL} = 2 \text{ ms}$  (approx). These intervals are not shown to scale.

# PIC18(L)F1XK22

## 18.4.1 PRI\_IDLE MODE

This mode is unique among the three low-power Idle modes, in that it does not disable the primary device clock. For timing sensitive applications, this allows for the fastest resumption of device operation with its more accurate primary clock source, since the clock source does not have to “warm-up” or transition from another oscillator.

PRI\_IDLE mode is entered from PRI\_RUN mode by setting the IDLEN bit and executing a SLEEP instruction. If the device is in another Run mode, set IDLEN first, then clear the SCS bits and execute SLEEP. Although the CPU is disabled, the peripherals continue to be clocked from the primary clock source specified by the FOSC<3:0> Configuration bits. The OSTS bit remains set (see Figure 18-3).

When a wake event occurs, the CPU is clocked from the primary clock source. A delay of interval TcSD is required between the wake event and when code execution starts. This is required to allow the CPU to become ready to execute instructions. After the wake-up, the OSTS bit remains set. The IDLEN and SCS bits are not affected by the wake-up (see Figure 18-4).

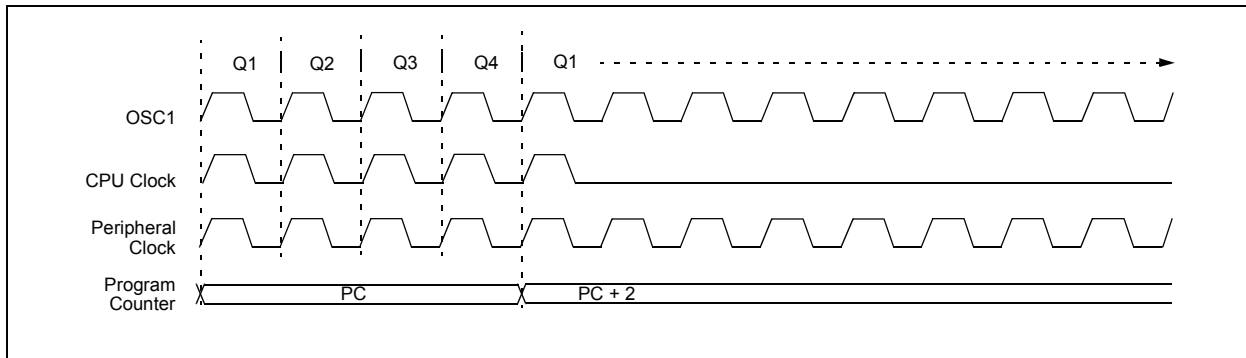
## 18.4.2 SEC\_IDLE MODE

In SEC\_IDLE mode, the CPU is disabled but the peripherals continue to be clocked from the Timer1 oscillator. This mode is entered from SEC\_RUN by setting the IDLEN bit and executing a SLEEP instruction. If the device is in another Run mode, set the IDLEN bit first, then set the SCS<1:0> bits to ‘01’ and execute SLEEP. When the clock source is switched to the Timer1 oscillator, the primary oscillator is shut down, the OSTS bit is cleared and the T1RUN bit is set.

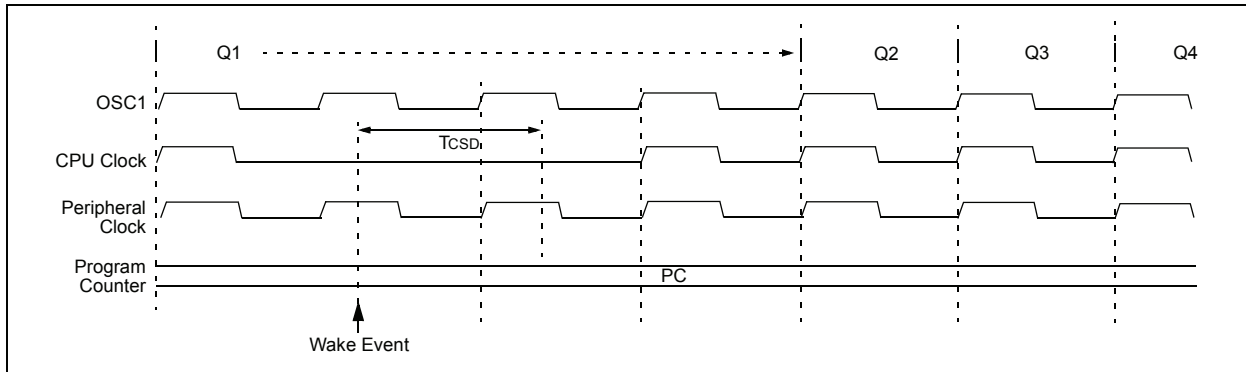
When a wake event occurs, the peripherals continue to be clocked from the Timer1 oscillator. After an interval of TcSD following the wake event, the CPU begins executing code being clocked by the Timer1 oscillator. The IDLEN and SCS bits are not affected by the wake-up; the Timer1 oscillator continues to run (see Figure 18-4).

**Note:** The Timer1 oscillator should already be running prior to entering SEC\_IDLE mode. If the T1OSCEN bit is not set when the SLEEP instruction is executed, the main system clock will continue to operate in the previously selected mode and the corresponding IDLE mode will be entered (i.e., PRI\_IDLE or RC\_IDLE).

**FIGURE 18-3: TRANSITION TIMING FOR ENTRY TO IDLE MODE**



**FIGURE 18-4: TRANSITION TIMING FOR WAKE FROM IDLE TO RUN MODE**





## 18.4.3 RC\_IDLE MODE

In RC\_IDLE mode, the CPU is disabled but the peripherals continue to be clocked from the internal oscillator block from the HFINTOSC multiplexer output. This mode allows for controllable power conservation during Idle periods.

From RC\_RUN, this mode is entered by setting the IDLEN bit and executing a SLEEP instruction. If the device is in another Run mode, first set IDLEN, then set the SCS1 bit and execute SLEEP. It is recommended that SCS0 also be cleared, although its value is ignored, to maintain software compatibility with future devices. The HFINTOSC multiplexer may be used to select a higher clock frequency by modifying the IRCF bits before executing the SLEEP instruction. When the clock source is switched to the HFINTOSC multiplexer, the primary oscillator is shut down and the OSTS bit is cleared.

If the IRCF bits are set to any non-zero value, or the INTSRC bit is set, the HFINTOSC output is enabled. The IOSF bit becomes set, after the HFINTOSC output becomes stable, after an interval of TIOBST. Clocks to the peripherals continue while the HFINTOSC source stabilizes. If the IRCF bits were previously at a non-zero value, or INTSRC was set before the SLEEP instruction was executed and the HFINTOSC source was already stable, the IOSF bit will remain set. If the IRCF bits and INTSRC are all clear, the HFINTOSC output will not be enabled, the IOSF bit will remain clear and there will be no indication of the current clock source.

When a wake event occurs, the peripherals continue to be clocked from the HFINTOSC multiplexer output. After a delay of TCSD following the wake event, the CPU begins executing code being clocked by the HFINTOSC multiplexer. The IDLEN and SCS bits are not affected by the wake-up. The LFINTOSC source will continue to run if either the WDT or the Fail-Safe Clock Monitor is enabled.

## 18.5 Exiting Idle and Sleep Modes

An exit from Sleep mode or any of the Idle modes is triggered by any one of the following:

- an interrupt
- a Reset
- a Watchdog Time-out

This section discusses the triggers that cause exits from power-managed modes. The clocking subsystem actions are discussed in each of the power-managed modes (see [Section 18.2 “Run Modes”](#), [Section 18.3 “Sleep Mode”](#) and [Section 18.4 “Idle Modes”](#)).

### 18.5.1 EXIT BY INTERRUPT

Any of the available interrupt sources can cause the device to exit from an Idle mode or the Sleep mode to a Run mode. To enable this functionality, an interrupt source must be enabled by setting its enable bit in one of the INTCON or PIE registers. The PEIE bit must also be set. If the desired interrupt enable bit is in a PIE register. The exit sequence is initiated when the corresponding interrupt flag bit is set.

The instruction immediately following the SLEEP instruction is executed on all exits by interrupt from Idle or Sleep modes. Code execution then branches to the interrupt vector if the GIE/GIEH bit of the INTCON register is set, otherwise code execution continues without branching (see [Section 7.0 “Interrupts”](#)).

A fixed delay of interval TCSD following the wake event is required when leaving Sleep and Idle modes. This delay is required for the CPU to prepare for execution. Instruction execution resumes on the first clock cycle following this delay.

### 18.5.2 EXIT BY WDT TIME-OUT

A WDT time-out will cause different actions depending on which power-managed mode the device is in when the time-out occurs.

If the device is not executing code (all Idle modes and Sleep mode), the time-out will result in an exit from the power-managed mode (see [Section 18.2 “Run Modes”](#) and [Section 18.3 “Sleep Mode”](#)). If the device is executing code (all Run modes), the time-out will result in a WDT Reset (see [Section 22.2 “Watchdog Timer \(WDT\)”](#)).

The WDT timer and postscaler are cleared by any one of the following:

- executing a SLEEP instruction
- executing a CLRWDT instruction
- the loss of the currently selected clock source when the Fail-Safe Clock Monitor is enabled
- modifying the IRCF bits in the OSCCON register when the internal oscillator block is the device clock source

# PIC18(L)F1XK22

## 18.5.3 EXIT BY RESET

Exiting Sleep and Idle modes by Reset causes code execution to restart at address 0. See [Section 21.0 “Reset”](#) for more details.

The exit delay time from Reset to the start of code execution depends on both the clock sources before and after the wake-up and the type of oscillator. Exit delays are summarized in [Table 18-2](#).

## 18.5.4 EXIT WITHOUT AN OSCILLATOR START-UP DELAY

Certain exits from power-managed modes do not invoke the OST at all. There are two cases:

- PRI\_IDLE mode, where the primary clock source is not stopped and
- the primary clock source is not any of the LP, XT, HS or HSPLL modes.

In these instances, the primary clock source either does not require an oscillator start-up delay since it is already running (PRI\_IDLE), or normally does not require an oscillator start-up delay (RC, EC, INTOSC, and INTOSCIO modes). However, a fixed delay of interval T<sub>CSD</sub> following the wake event is still required when leaving Sleep and Idle modes to allow the CPU to prepare for execution. Instruction execution resumes on the first clock cycle following this delay.

**TABLE 18-2: EXIT DELAY ON WAKE-UP BY RESET FROM SLEEP MODE OR ANY IDLE MODE (BY CLOCK SOURCES)**

Clock Source before Wake-up	Clock Source after Wake-up	Exit Delay	Clock Ready Status Bit (OSCCON)
Primary Device Clock (PRI_IDLE mode)	LP, XT, HS	T <sub>CSD</sub> <sup>(1)</sup>	OSTS
	HSPLL		
	EC, RC		
	HFINTOSC <sup>(2)</sup>		IOSF
T1OSC or LFINTOSC <sup>(1)</sup>	LP, XT, HS	T <sub>OST</sub> <sup>(3)</sup>	OSTS
	HSPLL	T <sub>OST</sub> + t <sub>PLL</sub> <sup>(3)</sup>	
	EC, RC	T <sub>CSD</sub> <sup>(1)</sup>	
	HFINTOSC <sup>(1)</sup>	T <sub>IOBST</sub> <sup>(4)</sup>	IOSF
HFINTOSC <sup>(2)</sup>	LP, XT, HS	T <sub>OST</sub> <sup>(4)</sup>	OSTS
	HSPLL	T <sub>OST</sub> + t <sub>PLL</sub> <sup>(3)</sup>	
	EC, RC	T <sub>CSD</sub> <sup>(1)</sup>	
	HFINTOSC <sup>(1)</sup>	None	IOSF
None (Sleep mode)	LP, XT, HS	T <sub>OST</sub> <sup>(3)</sup>	OSTS
	HSPLL	T <sub>OST</sub> + t <sub>PLL</sub> <sup>(3)</sup>	
	EC, RC	T <sub>CSD</sub> <sup>(1)</sup>	
	HFINTOSC <sup>(1)</sup>	T <sub>IOBST</sub> <sup>(4)</sup>	IOSF

**Note 1:** T<sub>CSD</sub> is a required delay when waking from Sleep and all Idle modes and runs concurrently with any other required delays (see [Section 18.4 “Idle Modes”](#)). On Reset, HFINTOSC defaults to 1 MHz.

**2:** Includes both the HFINTOSC 16 MHz source and postscaler derived frequencies.

**3:** T<sub>OST</sub> is the Oscillator Start-up Timer. t<sub>PLL</sub> is the PLL Lock-out Timer (parameter F12).

**4:** Execution continues during the HFINTOSC stabilization period, T<sub>IOBST</sub>.

## 19.0 SR LATCH

The module consists of a single SR latch with multiple Set and Reset inputs as well as selectable latch output. The SR latch module includes the following features:

- Programmable input selection
- SR latch output is available internally/externally
- Selectable Q and  $\bar{Q}$  output
- Firmware Set and Reset

### 19.1 Latch Operation

The latch is a Set-Reset latch that does not depend on a clock source. Each of the Set and Reset inputs are active-high. The latch can be Set or Reset by CxOUT, INT1 pin, or variable clock. Additionally the SRPS and the SRPR bits of the SRCON0 register may be used to Set or Reset the SR latch, respectively. The latch is reset-dominant, therefore, if both Set and Reset inputs are high the latch will go to the Reset state. Both the SRPS and SRPR bits are self resetting which means that a single write to either of the bits is all that is necessary to complete a latch Set or Reset operation.

### 19.2 Latch Output

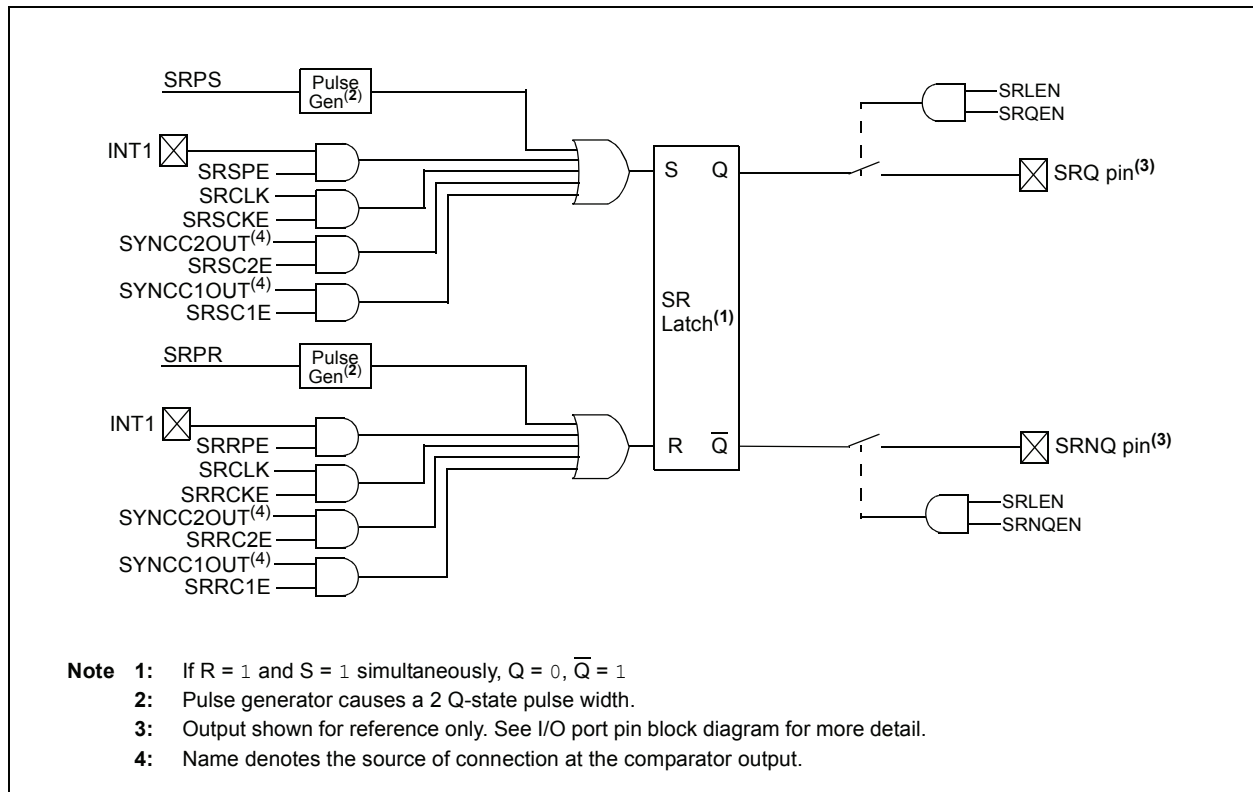
The SRQEN and SRNQEN bits of the SRCON0 register control the latch output selection. Both of the SR latch's outputs may be directly output to an independent I/O pin. Control is determined by the state of bits SRQEN and SRNQEN in registers SRCON0.

The applicable TRIS bit of the corresponding port must be cleared to enable the port pin output driver.

### 19.3 Effects of a Reset

Upon any device Reset, the SR latch is not initialized. The user's firmware is responsible to initialize the latch output before enabling it to the output pins.

**FIGURE 19-1: SR LATCH SIMPLIFIED BLOCK DIAGRAM**



# PIC18(L)F1XK22

**TABLE 19-1: SRCLK FREQUENCY TABLE**

SRCLK	Divider	Fosc = 20 MHz	Fosc = 16 MHz	Fosc = 8 MHz	Fosc = 4 MHz	Fosc = 1 MHz
111	512	25.6 $\mu$ s	32 $\mu$ s	64 $\mu$ s	128 $\mu$ s	512 $\mu$ s
110	256	12.8 $\mu$ s	16 $\mu$ s	32 $\mu$ s	64 $\mu$ s	256 $\mu$ s
101	128	6.4 $\mu$ s	8 $\mu$ s	16 $\mu$ s	32 $\mu$ s	128 $\mu$ s
100	64	3.2 $\mu$ s	4 $\mu$ s	8 $\mu$ s	16 $\mu$ s	64 $\mu$ s
011	32	1.6 $\mu$ s	2 $\mu$ s	4 $\mu$ s	8 $\mu$ s	32 $\mu$ s
010	16	0.8 $\mu$ s	1 $\mu$ s	2 $\mu$ s	4 $\mu$ s	16 $\mu$ s
001	8	0.4 $\mu$ s	0.5 $\mu$ s	1 $\mu$ s	2 $\mu$ s	8 $\mu$ s
000	4	0.2 $\mu$ s	0.25 $\mu$ s	0.5 $\mu$ s	1 $\mu$ s	4 $\mu$ s

**REGISTER 19-1: SRCON0: SR LATCH CONTROL REGISTER**

R/W-0	R/W-0	R/W-0	R/W-0	R/W-0	R/W-0	R/W-0	R/W-0
SRLEN	SRCLK2	SRCLK1	SRCLK0	SRQEN	SRNQEN	SRPS	SRPR
bit 7							bit 0

**Legend:**

R = Readable bit	W = Writable bit	U = Unimplemented	C = Clearable only bit
-n = Value at POR	'1' = Bit is set	'0' = Bit is cleared	x = Bit is unknown

- bit 7      **SRLEN:** SR Latch Enable bit<sup>(1)</sup>  
             1 = SR latch is enabled  
             0 = SR latch is disabled
- bit 6-4    **SRCLK<2:0>**<sup>(1)</sup>: SR Latch Clock divider bits  
             000 = 1/4 Peripheral cycle clock  
             001 = 1/8 Peripheral cycle clock  
             010 = 1/16 Peripheral cycle clock  
             011 = 1/32 Peripheral cycle clock  
             100 = 1/64 Peripheral cycle clock  
             101 = 1/128 Peripheral cycle clock  
             110 = 1/256 Peripheral cycle clock  
             111 = 1/512 Peripheral cycle clock
- bit 3      **SRQEN:** SR Latch Q Output Enable bit  
             1 = Q is present on the RA2 pin  
             0 = Q is internal only
- bit 2      **SRNQEN:** SR Latch  $\bar{Q}$  Output Enable bit  
             1 =  $\bar{Q}$  is present on the RC4 pin  
             0 =  $\bar{Q}$  is internal only
- bit 1      **SRPS:** Pulse Set Input of the SR Latch bit  
             1 = Pulse input  
             0 = Always reads back '0'
- bit 0      **SRPR:** Pulse Reset Input of the SR Latch bit  
             1 = Pulse input  
             0 = Always reads back '0'

**Note 1:** Changing the SRCLK bits while the SR latch is enabled may cause false triggers to the set and Reset inputs of the latch.

## REGISTER 19-2: SRCON1: SR LATCH CONTROL REGISTER 1

R/W-0	R/W-0	R/W-0	R/W-0	R/W-0	R/W-0	R/W-0	R/W-0
SRSPE	SRSCKE	SRSC2E	SRSC1E	SRRPE	SRRCKE	SRRC2E	SRRC1E
bit 7							bit 0

### Legend:

R = Readable bit	W = Writable bit	U = Unimplemented	C = Clearable only bit
-n = Value at POR	'1' = Bit is set	'0' = Bit is cleared	x = Bit is unknown

bit 7	<b>SRSPE:</b> SR Latch Peripheral Set Enable bit 1 = INT1 pin status sets SR latch 0 = INT1 pin status has no effect on SR latch
bit 6	<b>SRSCKE:</b> SR Latch Set Clock Enable bit 1 = Set input of SR latch is pulsed with SRCLK 0 = Set input of SR latch is not pulsed with SRCLK
bit 5	<b>SRSC2E:</b> SR Latch C2 Set Enable bit 1 = C2 Comparator output sets SR latch 0 = C2 Comparator output has no effect on SR latch
bit 4	<b>SRSC1E:</b> SR Latch C1 Set Enable bit 1 = C1 Comparator output sets SR latch 0 = C1 Comparator output has no effect on SR latch
bit 3	<b>SRRPE:</b> SR Latch Peripheral Reset Enable bit 1 = INT1 pin resets SR latch 0 = INT1 pin has no effect on SR latch
bit 2	<b>SRRCKE:</b> SR Latch Reset Clock Enable bit 1 = Reset input of SR latch is pulsed with SRCLK 0 = Reset input of SR latch is not pulsed with SRCLK
bit 1	<b>SRRC2E:</b> SR Latch C2 Reset Enable bit 1 = C2 Comparator output resets SR latch 0 = C2 Comparator output has no effect on SR latch
bit 0	<b>SRRC1E:</b> SR Latch C1 Reset Enable bit 1 = C1 Comparator output resets SR latch 0 = C1 Comparator output has no effect on SR latch

## TABLE 19-2: REGISTERS ASSOCIATED WITH THE SR LATCH

Name	Bit 7	Bit 6	Bit 5	Bit 4	Bit 3	Bit 2	Bit 1	Bit 0	Reset Values on page
CM2CON1	MC1OUT	MC2OUT	C1RSEL	C2RSEL	C1HYS	C2HYS	C1SYNC	C2SYNC	256
INTCON3	INT2IP	INT1IP	—	INT2IE	INT1IE	—	INT2IF	INT1IF	253
SRCON0	SRLLEN	SRCLK2	SRCLK1	SRCLK0	SRQEN	SRNQEN	SRPS	SRPR	256
SRCON1	SRSPE	SRSCKE	SRSC2E	SRSC1E	SRRPE	SRRCKE	SRRC2E	SRRC1E	256
TRISC	TRISC7	TRISC6	TRISC5	TRISC4	TRISC3	TRISC2	TRISC1	TRISC0	256

**Legend:** Shaded cells are not used with the SR Latch module.

# PIC18(L)F1XK22

---

NOTES:

## 20.0 VOLTAGE REFERENCES

There are two independent voltage references available:

- Programmable Voltage Reference
- 1.024V Fixed Voltage Reference

### 20.1 Voltage Reference

The voltage reference module provides an internally generated voltage reference for the comparators and the DAC module. The following features are available:

- Independent from comparator operation
- Single 32-level voltage ranges
- Output clamped to VSS
- Ratiometric with VDD
- 1.024V Fixed Voltage Reference (FVR)

The VREFCON1 register ([Register 20-2](#)) controls the Voltage Reference module shown in [Figure 20-1](#).

#### EQUATION 20-1: VREF OUTPUT VOLTAGE

***IF DIEN = 1***

$$V_{OUT} = \left( (V_{SOURCE+} - V_{SOURCE-}) \times \frac{DAC1R[4:0]}{2^5} + V_{SOURCE-} \right)$$

***IF DIEN = 0 & DILPS = 1 & DAC1R[4:0] = 1111:***

$$V_{OUT} = V_{SOURCE+}$$

***IF DIEN = 0 & DILPS = 1 & DAC1R[4:0] = 0000:***

$$V_{OUT} = V_{SOURCE-}$$

#### 20.1.3 OUTPUT RATIOMETRIC TO VDD

The comparator voltage reference is VDD derived and therefore, the VREF output changes with fluctuations in VDD. The tested absolute accuracy of the Comparator Voltage Reference can be found in [Section 25.0 “Electrical Specifications”](#).

#### 20.1.4 VOLTAGE REFERENCE OUTPUT

The VREF voltage reference can be output to the device CVREF pin by setting the DAC1OE bit of the VREFCON1 register to ‘1’. Selecting the reference voltage for output on the VREF pin automatically overrides the digital output buffer and digital input threshold detector functions of that pin. Reading the CVREF pin when it has been configured for reference voltage output will always return a ‘0’.

Due to the limited current drive capability, a buffer must be used on the voltage reference output for external connections to CVREF. [Figure 20-2](#) shows an example buffering technique.

#### 20.1.1 INDEPENDENT OPERATION

The voltage reference is independent of the comparator configuration. Setting the D1EN bit of the VREFCON1 register will enable the voltage reference by allowing current to flow in the VREF voltage divider. When the D1EN bit is cleared, current flow in the VREF voltage divider is disabled minimizing the power drain of the voltage reference peripheral.

#### 20.1.2 OUTPUT VOLTAGE SELECTION

The VREF voltage reference has 32 voltage level ranges. The 32 levels are set with the DAC1R<4:0> bits of the VREFCON2 register.

The VREF output voltage is determined by the following equations:

#### 20.1.5 OPERATION DURING SLEEP

When the device wakes up from Sleep through an interrupt or a Watchdog Timer time-out, the contents of the RECON1 register are not affected. To minimize current consumption in Sleep mode, the voltage reference should be disabled.

#### 20.1.6 EFFECTS OF A RESET

A device Reset affects the following:

- Voltage reference is disabled
- Fixed voltage reference is disabled
- VREF is removed from the CVREF pin
- The DAC1R<4:0> range select bits are cleared

# PIC18(L)F1XK22

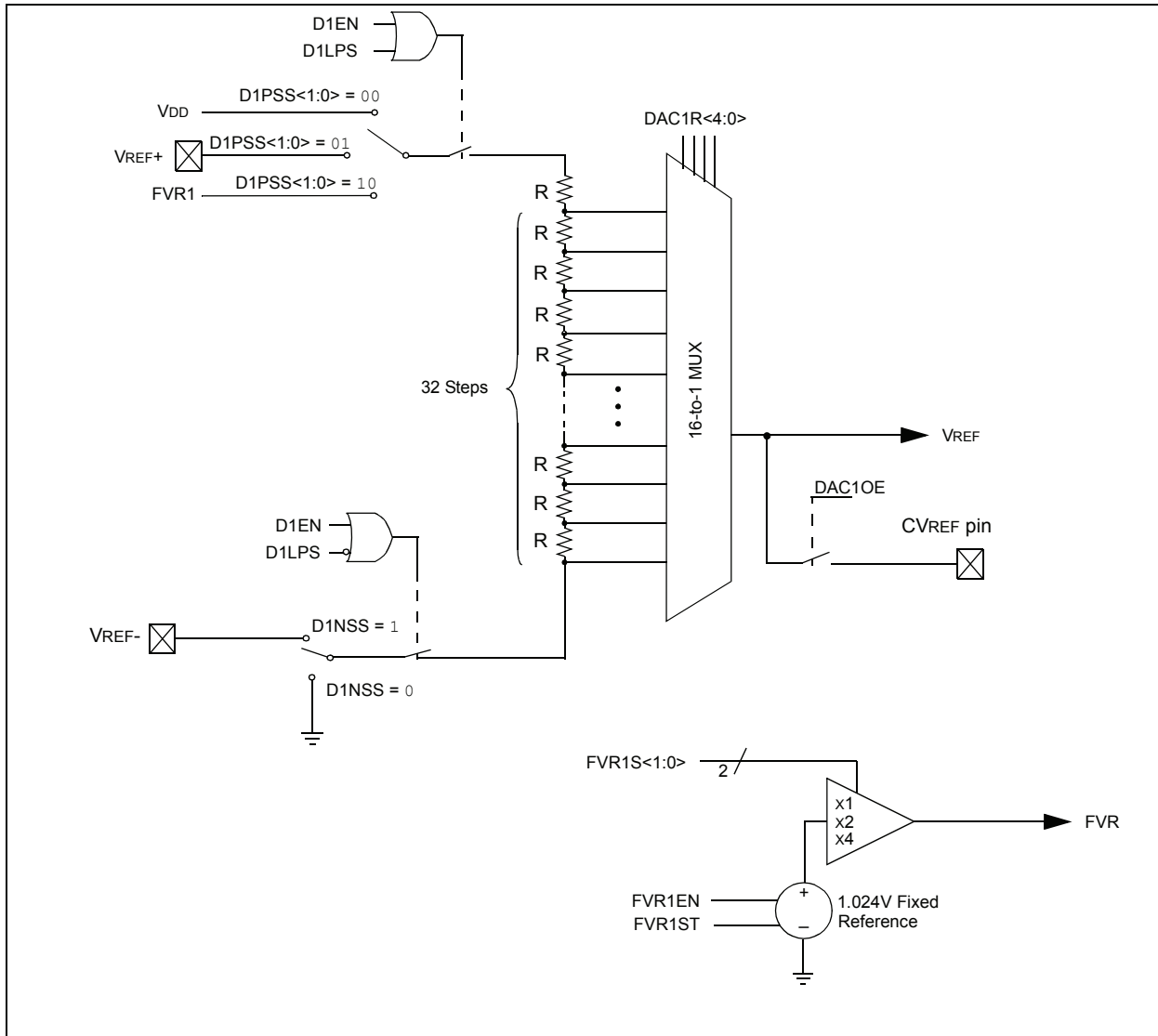
## 20.2 FVR Reference Module

The FVR is a stable Fixed Voltage Reference, independent of VDD, with a nominal output voltage of 1.024V. This reference can be enabled by setting the FVR1EN bit of the VREFCON0 register to '1'. The FVR can be routed to the comparators or an ADC input channel.

### 20.2.1 FVR STABILIZATION PERIOD

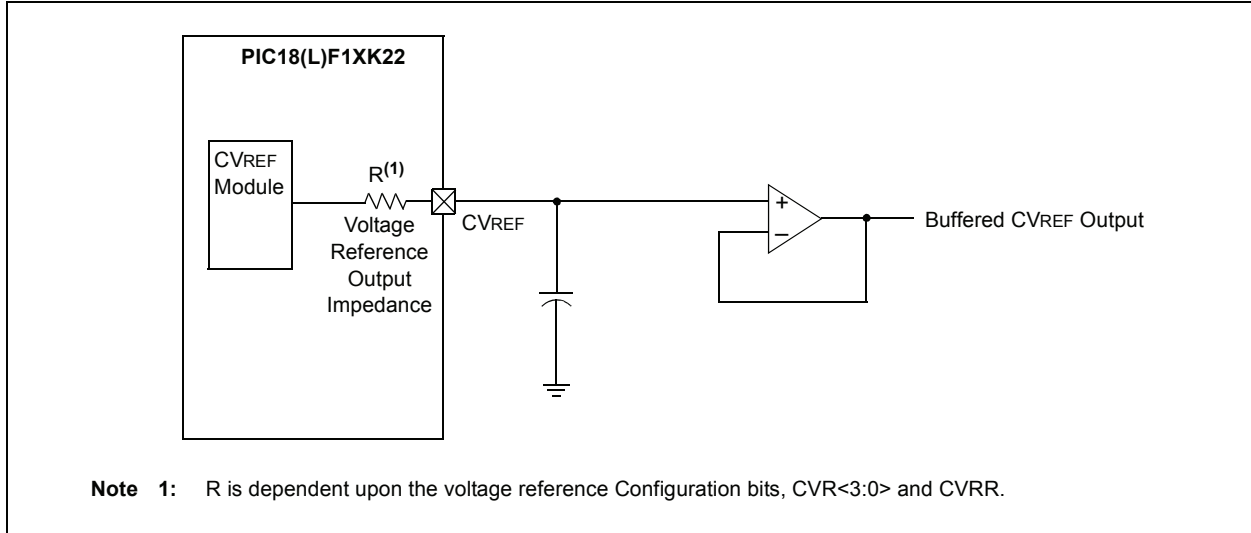
When the Fixed Voltage Reference module is enabled, it will require some time for the reference and its amplifier circuits to stabilize. The user program must include a small delay routine to allow the module to settle. The FVR1ST stable bit of the VREFCON0 register also indicates that the FVR has been operating long enough to be stable. See [Section 25.0 "Electrical Specifications"](#) for the minimum delay requirement.

**FIGURE 20-1: VOLTAGE REFERENCE BLOCK DIAGRAM**





**FIGURE 20-2: VOLTAGE REFERENCE OUTPUT BUFFER EXAMPLE**



**REGISTER 20-1: VREFCON0: VOLTAGE REFERENCE CONTROL REGISTER 0**

R/W-0	R-0	R/W-0	R/W-1	U-0	U-0	U-0	U-0	
FVR1EN	FVR1ST	FVR1S1	FVR1S0	—	—	—	—	
bit 7								bit 0

**Legend:**

R = Readable bit                      W = Writable bit                      U = Unimplemented bit, read as '0'  
 -n = Value at POR                      '1' = Bit is set                      '0' = Bit is cleared                      x = Bit is unknown

- bit 7            **FVR1EN:** Fixed Voltage Reference 1 Enable bit  
 0 = FVR is disabled  
 1 = FVR is enabled
- bit 6            **FVR1ST:** Fixed Voltage Reference 1 Stable bit  
 0 = FVR is not stable  
 1 = FVR is stable
- bit 5-4        **FVR1S<1:0>:** Fixed Voltage Reference 1 Voltage Select bits  
 00 = Reserved, do not use  
 01 = 1.024V (x1)  
 10 = 2.048V (x2)  
 11 = 4.096V (x4)
- bit 3-0        **Unimplemented:** Read as '0'

# PIC18(L)F1XK22

## REGISTER 20-2: VREFCON1: VOLTAGE REFERENCE CONTROL REGISTER 1

R/W-0	R/W-0	R/W-0	U-0	R/W-0	R/W-0	U-0	R/W-0
D1EN	D1LPS	DAC1OE	—	D1PSS1	D1PSS0	—	D1NSS
bit 7							bit 0

### Legend:

R = Readable bit                      W = Writable bit                      U = Unimplemented bit, read as '0'  
 -n = Value at POR                      '1' = Bit is set                      '0' = Bit is cleared                      x = Bit is unknown

- bit 7            **D1EN:** DAC 1 Enable bit  
                  0 = DAC 1 is disabled  
                  1 = DAC 1 is enabled
- bit 6            **D1LPS:** DAC 1 Low-Power Voltage State Select bit  
                  0 = VDAC = DAC1 Negative reference source selected  
                  1 = VDAC = DAC1 Positive reference source selected
- bit 5            **DAC1OE:** DAC 1 Voltage Output Enable bit  
                  1 = DAC 1 voltage level is also outputed on the RA0/AN0/CVREF/VREF-/C1IN+/INT0/PGD pin  
                  0 = DAC 1 voltage level is disconnected from RA0/AN0/CVREF/VREF-/C1IN+/INT0/PGD pin pin
- bit 4            **Unimplemented:** Read as '0'
- bit 3-2        **D1PSS<1:0>:** DAC 1 Positive Source Select bits  
                  00 = VDD  
                  01 = VREF+  
                  10 = FVR output  
                  11 = Reserved, do not use
- bit 1            **Unimplemented:** Read as '0'
- bit 0            **D1NSS:** DAC1 Negative Source Select bits  
                  0 = Vss  
                  1 = VREF-

## REGISTER 20-3: VREFCON2: VOLTAGE REFERENCE CONTROL REGISTER 2

U-0	U-0	U-0	R/W-0	R/W-0	R/W-0	R/W-0	R/W-0
—	—	—	DAC1R4	DAC1R3	DAC1R2	DAC1R1	DAC1R0
bit 7							bit 0

### Legend:

R = Readable bit                      W = Writable bit                      U = Unimplemented bit, read as '0'  
 -n = Value at POR                      '1' = Bit is set                      '0' = Bit is cleared                      x = Bit is unknown

- bit 7-5        **Unimplemented:** Read as '0'
- bit 4-0        **DAC1R<4:0>:** DAC1 Voltage Output Select bits  

$$V_{OUT} = ((V_{SOURCE+}) - (V_{SOURCE-})) * (DAC1R<4:0> / (2^5)) + V_{SOURCE-}$$

**Note 1:** The output select bits are always right justified to ensure that any number of bits can be used without affecting the register layout

**TABLE 20-1: REGISTERS ASSOCIATED WITH VOLTAGE REFERENCE**

Name	Bit 7	Bit 6	Bit 5	Bit 4	Bit 3	Bit 2	Bit 1	Bit 0	Reset Values on page
VREFCON0	FVR1EN	FVR1ST	FVR1S1	FVR1S0	—	—	—	—	255
VREFCON1	D1EN	D1LPS	DAC1OE	—	D1PSS1	D1PSS0	—	D1NSS	255
VREFCON2	—	—	—	DAC1R4	DAC1R3	DAC1R2	DAC1R1	DAC1R0	255
TRISA	—	—	TRISA5	TRISA4	—	TRISA2	TRISA1	TRISA0	256

**Legend:** Shaded cells are not used with the comparator voltage reference.

**Note 1:** PORTA pins are enabled based on oscillator configuration.

# PIC18(L)F1XK22

---

NOTES:

## 21.0 RESET

The PIC18(L)F1XK22 devices differentiate between various kinds of Reset:

- Power-on Reset (POR)
- $\overline{\text{MCLR}}$  Reset during normal operation
- $\overline{\text{MCLR}}$  Reset during power-managed modes
- Watchdog Timer (WDT) Reset (during execution)
- Programmable Brown-out Reset (BOR)
- RESET Instruction
- Stack Full Reset
- Stack Underflow Reset

This section discusses Resets generated by  $\overline{\text{MCLR}}$ , POR and BOR and covers the operation of the various start-up timers. Stack Reset events are covered in [Section 3.1.2.4 “Stack Overflow and Underflow Resets”](#). WDT Resets are covered in [Section 22.2 “Watchdog Timer \(WDT\)”](#).

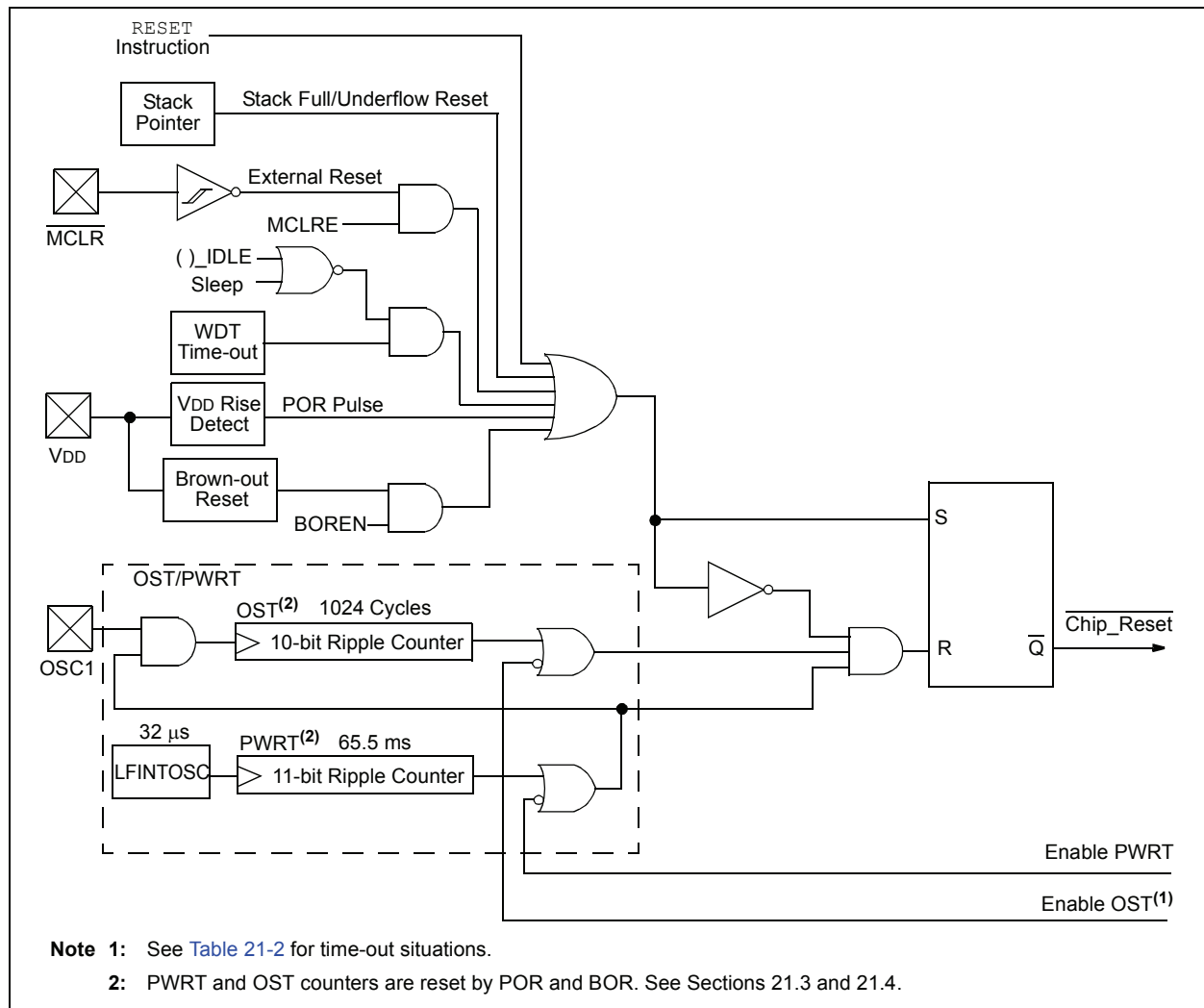
A simplified block diagram of the On-Chip Reset Circuit is shown in [Figure 21-1](#).

## 21.1 RCON Register

Device Reset events are tracked through the RCON register ([Register 21-1](#)). The lower five bits of the register indicate that a specific Reset event has occurred. In most cases, these bits can only be cleared by the event and must be set by the application after the event. The state of these flag bits, taken together, can be read to indicate the type of Reset that just occurred. This is described in more detail in [Section 21.6 “Reset State of Registers”](#).

The RCON register also has control bits for setting interrupt priority (IPEN) and software control of the BOR (SBOREN). Interrupt priority is discussed in [Section 7.0 “Interrupts”](#). BOR is covered in [Section 21.4 “Brown-out Reset \(BOR\)”](#).

**FIGURE 21-1: SIMPLIFIED BLOCK DIAGRAM OF ON-CHIP RESET CIRCUIT**



# PIC18(L)F1XK22

## REGISTER 21-1: RCON: RESET CONTROL REGISTER

R/W-0	R/W-1	U-0	R/W-1	R-1	R-1	R/W-0	R/W-0
IPEN	SBOREN <sup>(1)</sup>	—	$\overline{\text{RI}}$	$\overline{\text{TO}}$	$\overline{\text{PD}}$	$\overline{\text{POR}}$ <sup>(2)</sup>	$\overline{\text{BOR}}$
bit 7							bit 0

### Legend:

R = Readable bit

W = Writable bit

U = Unimplemented bit, read as '0'

-n = Value at POR

'1' = Bit is set

'0' = Bit is cleared

x = Bit is unknown

- bit 7      **IPEN:** Interrupt Priority Enable bit  
 1 = Enable priority levels on interrupts  
 0 = Disable priority levels on interrupts (PIC16CXXX Compatibility mode)
- bit 6      **SBOREN:** BOR Software Enable bit<sup>(1)</sup>  
If BOREN<1:0> = 01:  
 1 = BOR is enabled  
 0 = BOR is disabled  
If BOREN<1:0> = 00, 10 or 11:  
 Bit is disabled and read as '0'.
- bit 5      **Unimplemented:** Read as '0'
- bit 4       **$\overline{\text{RI}}$ :** RESET Instruction Flag bit  
 1 = The RESET instruction was not executed (set by firmware or Power-on Reset)  
 0 = The RESET instruction was executed causing a device Reset (must be set in firmware after a code-executed Reset occurs)
- bit 3       **$\overline{\text{TO}}$ :** Watchdog Time-out Flag bit  
 1 = Set by power-up, CLRWD $\overline{\text{T}}$  instruction or SLEEP instruction  
 0 = A WDT time-out occurred
- bit 2       **$\overline{\text{PD}}$ :** Power-down Detection Flag bit  
 1 = Set by power-up or by the CLRWD $\overline{\text{T}}$  instruction  
 0 = Set by execution of the SLEEP instruction
- bit 1       **$\overline{\text{POR}}$ :** Power-on Reset Status bit<sup>(2)</sup>  
 1 = No Power-on Reset occurred  
 0 = A Power-on Reset occurred (must be set in software after a Power-on Reset occurs)
- bit 0       **$\overline{\text{BOR}}$ :** Brown-out Reset Status bit<sup>(3)</sup>  
 1 = A Brown-out Reset has not occurred (set by firmware only)  
 0 = A Brown-out Reset occurred (must be set by firmware after a POR or Brown-out Reset occurs)

**Note 1:** If SBOREN is enabled, its Reset state is '1'; otherwise, it is '0'.

**Note 2:** The actual Reset value of  $\overline{\text{POR}}$  is determined by the type of device Reset. See the notes following this register and [Section 21.6 "Reset State of Registers"](#) for additional information.

**Note 3:** See [Table 21-3](#).

## 21.2 Master Clear ( $\overline{\text{MCLR}}$ )

The  $\overline{\text{MCLR}}$  pin provides a method for triggering an external Reset of the device. A Reset is generated by holding the pin low. These devices have a noise filter in the  $\overline{\text{MCLR}}$  Reset path which detects and ignores small pulses.

The  $\overline{\text{MCLR}}$  pin is not driven low by any internal Resets, including the WDT.

In PIC18(L)F1XK22 devices, the  $\overline{\text{MCLR}}$  input can be disabled with the MCLRE Configuration bit. When  $\overline{\text{MCLR}}$  is disabled, the pin becomes a digital input. See [Section 8.1 “PORTA, TRISA and LATA Registers”](#) for more information.

## 21.3 Power-on Reset (POR)

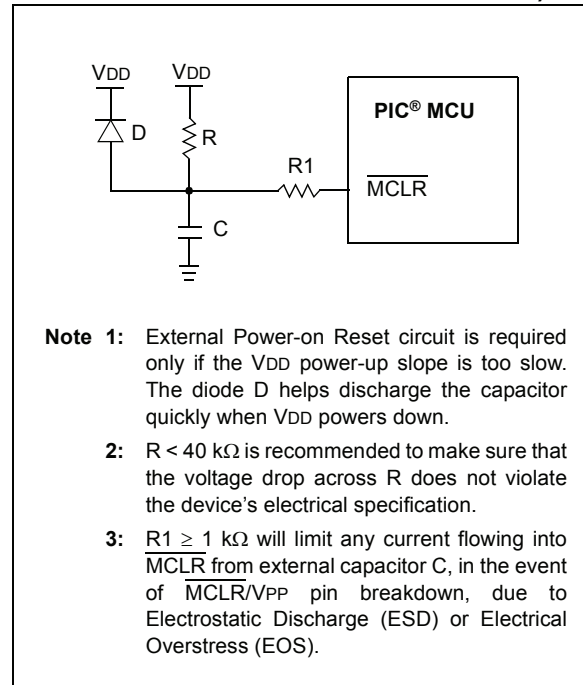
A Power-on Reset pulse is generated on-chip whenever VDD rises above a certain threshold. This allows the device to start in the initialized state when VDD is adequate for operation.

To take advantage of the POR circuitry, tie the  $\overline{\text{MCLR}}$  pin through a resistor (1 k $\Omega$  to 10 k $\Omega$ ) to VDD. This will eliminate external RC components usually needed to create a Power-on Reset delay.

When the device starts normal operation (i.e., exits the Reset condition), device operating parameters (voltage, frequency, temperature, etc.) must be met to ensure operation. If these conditions are not met, the device must be held in Reset until the operating conditions are met.

POR events are captured by the  $\overline{\text{POR}}$  bit of the RCON register. The state of the bit is set to '0' whenever a POR occurs; it does not change for any other Reset event.  $\overline{\text{POR}}$  is not reset to '1' by any hardware event. To capture multiple events, the user must manually set the bit to '1' by software following any POR.

**FIGURE 21-2: EXTERNAL POWER-ON RESET CIRCUIT (FOR SLOW VDD POWER-UP)**



# PIC18(L)F1XK22

## 21.4 Brown-out Reset (BOR)

PIC18(L)F1XK22 devices implement a BOR circuit that provides the user with a number of configuration and power-saving options. The BOR is controlled by the BORV<1:0> and BOREN<1:0> bits of the CONFIG2L Configuration register. There are a total of four BOR configurations which are summarized in Table 21-1.

The BOR threshold is set by the BORV<1:0> bits. If BOR is enabled (any values of BOREN<1:0>, except '00'), any drop of VDD below VBOR for greater than TBOR will reset the device. A Reset may or may not occur if VDD falls below VBOR for less than TBOR. The chip will remain in Brown-out Reset until VDD rises above VBOR.

If the Power-up Timer is enabled, it will be invoked after VDD rises above VBOR; it then will keep the chip in Reset for an additional time delay, TPWRT. If VDD drops below VBOR while the Power-up Timer is running, the chip will go back into a Brown-out Reset and the Power-up Timer will be initialized. Once VDD rises above VBOR, the Power-up Timer will execute the additional time delay.

BOR and the Power-on Timer (PWRT) are independently configured. Enabling BOR Reset does not automatically enable the PWRT.

### 21.4.1 SOFTWARE ENABLED BOR

When BOREN<1:0> = 01, the BOR can be enabled or disabled by the user in software. This is done with the SBOREN control bit of the RCON register. Setting SBOREN enables the BOR to function as previously described. Clearing SBOREN disables the BOR entirely. The SBOREN bit operates only in this mode; otherwise it is read as '0'.

Placing the BOR under software control gives the user the additional flexibility of tailoring the application to its environment without having to reprogram the device to change BOR configuration. It also allows the user to tailor device power consumption in software by eliminating the incremental current that the BOR consumes. While the BOR current is typically very small, it may have some impact in low-power applications.

**Note:** Even when BOR is under software control, the BOR Reset voltage level is still set by the BORV<1:0> Configuration bits. It cannot be changed by software.

### 21.4.2 DETECTING BOR

When BOR is enabled, the  $\overline{\text{BOR}}$  bit always resets to '0' on any BOR or POR event. This makes it difficult to determine if a BOR event has occurred just by reading the state of  $\overline{\text{BOR}}$  alone. A more reliable method is to simultaneously check the state of both  $\overline{\text{POR}}$  and  $\overline{\text{BOR}}$ . This assumes that the  $\overline{\text{POR}}$  and  $\overline{\text{BOR}}$  bits are reset to '1' by software immediately after any POR event. If BOR is '0' while  $\overline{\text{POR}}$  is '1', it can be reliably assumed that a BOR event has occurred.

### 21.4.3 DISABLING BOR IN SLEEP MODE

When BOREN<1:0> = 10, the BOR remains under hardware control and operates as previously described. Whenever the device enters Sleep mode, however, the BOR is automatically disabled. When the device returns to any other operating mode, BOR is automatically re-enabled.

This mode allows for applications to recover from brown-out situations, while actively executing code, when the device requires BOR protection the most. At the same time, it saves additional power in Sleep mode by eliminating the small incremental BOR current.

TABLE 21-1: BOR CONFIGURATIONS

BOR Configuration		Status of SBOREN (RCON<6>)	BOR Operation
BOREN1	BOREN0		
0	0	Unavailable	BOR disabled; must be enabled by reprogramming the Configuration bits.
0	1	Available	BOR enabled by software; operation controlled by SBOREN.
1	0	Unavailable	BOR enabled by hardware in Run and Idle modes, disabled during Sleep mode.
1	1	Unavailable	BOR enabled by hardware; must be disabled by reprogramming the Configuration bits.



## 21.5 Device Reset Timers

PIC18(L)F1XK22 devices incorporate three separate on-chip timers that help regulate the Power-on Reset process. Their main function is to ensure that the device clock is stable before code is executed. These timers are:

- Power-up Timer (PWRT)
- Oscillator Start-up Timer (OST)
- PLL Lock Time-out

### 21.5.1 POWER-UP TIMER (PWRT)

The Power-up Timer (PWRT) of PIC18(L)F1XK22 devices is an 11-bit counter which uses the LFINTOSC source as the clock input. This yields an approximate time interval of  $2048 \times 32 \mu\text{s} = 65.6 \text{ ms}$ . While the PWRT is counting, the device is held in Reset.

The power-up time delay depends on the LFINTOSC clock and will vary from chip-to-chip due to temperature and process variation. See [Section 25.0 “Electrical Specifications”](#) for details.

The PWRT is enabled by clearing the  $\overline{\text{PWRTE}}\text{N}$  Configuration bit.

### 21.5.2 OSCILLATOR START-UP TIMER (OST)

The Oscillator Start-up Timer (OST) provides a 1024 oscillator cycle (from OSC1 input) delay after the PWRT delay is over. This ensures that the crystal oscillator or resonator has started and stabilized.

The OST time-out is invoked only for XT, LP, HS and HSPLL modes and only on Power-on Reset, or on exit from all power-managed modes that stop the external oscillator.

### 21.5.3 PLL LOCK TIME-OUT

With the PLL enabled in its PLL mode, the time-out sequence following a Power-on Reset is slightly different from other oscillator modes. A separate timer is used to provide a fixed time-out that is sufficient for the PLL to lock to the main oscillator frequency. This PLL lock time-out ( $T_{\text{PLL}}$ ) is typically 2ms and follows the oscillator start-up time-out.

### 21.5.4 TIME-OUT SEQUENCE

On power-up, the time-out sequence is as follows:

1. After the POR pulse has cleared, PWRT time-out is invoked (if enabled).
2. Then, the OST is activated.

The total time-out will vary based on oscillator configuration and the status of the PWRT. [Figure 21-3](#), [Figure 21-4](#), [Figure 21-5](#), [Figure 21-6](#) and [Figure 21-7](#) all depict time-out sequences on power-up, with the Power-up Timer enabled and the device operating in HS Oscillator mode. Figures [21-3](#) through [21-6](#) also apply to devices operating in XT or LP modes. For devices in RC mode and with the PWRT disabled, on the other hand, there will be no time-out at all.

Since the time-outs occur from the POR pulse, if  $\overline{\text{MCLR}}$  is kept low long enough, all time-outs will expire, after which, bringing MCLR high will allow program execution to begin immediately ([Figure 21-5](#)). This is useful for testing purposes or to synchronize more than one PIC18(L)F1XK22 device operating in parallel.

**TABLE 21-2: TIME-OUT IN VARIOUS SITUATIONS**

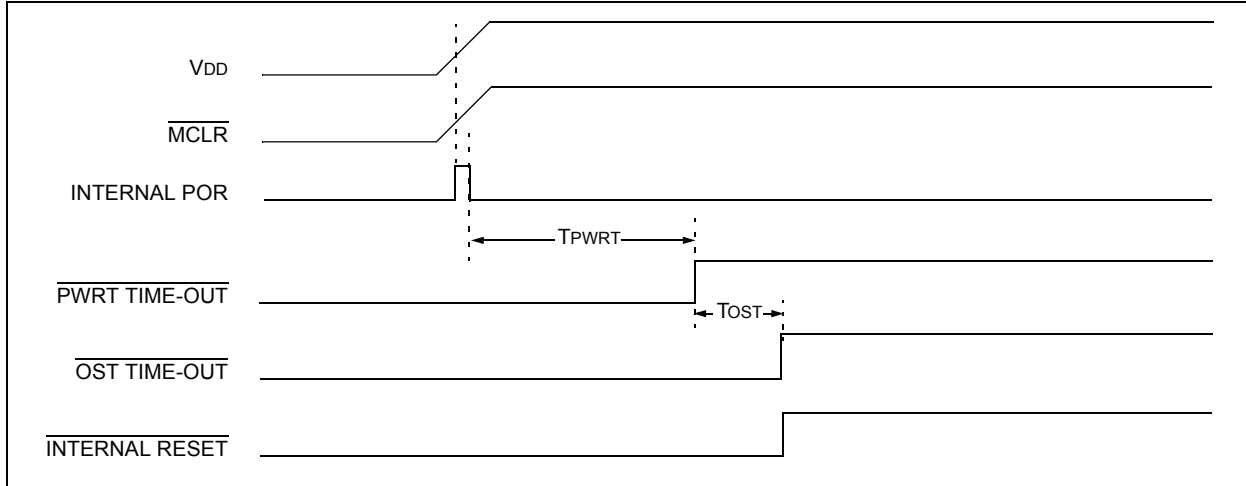
Oscillator Configuration	Power-up <sup>(2)</sup> and Brown-out		Exit from Power-Managed Mode
	$\overline{\text{PWRTE}}\text{N} = 0$	$\overline{\text{PWRTE}}\text{N} = 1$	
HSPLL	$66 \text{ ms}^{(1)} + 1024 T_{\text{osc}} + 2 \text{ ms}^{(2)}$	$1024 T_{\text{osc}} + 2 \text{ ms}^{(2)}$	$1024 T_{\text{osc}} + 2 \text{ ms}^{(2)}$
HS, XT, LP	$66 \text{ ms}^{(1)} + 1024 T_{\text{osc}}$	$1024 T_{\text{osc}}$	$1024 T_{\text{osc}}$
EC, ECIO	$66 \text{ ms}^{(1)}$	—	—
RC, RCIO	$66 \text{ ms}^{(1)}$	—	—
INTIO1, INTIO2	$66 \text{ ms}^{(1)}$	—	—

**Note 1:** 66 ms (65.5 ms) is the nominal Power-up Timer (PWRT) delay.

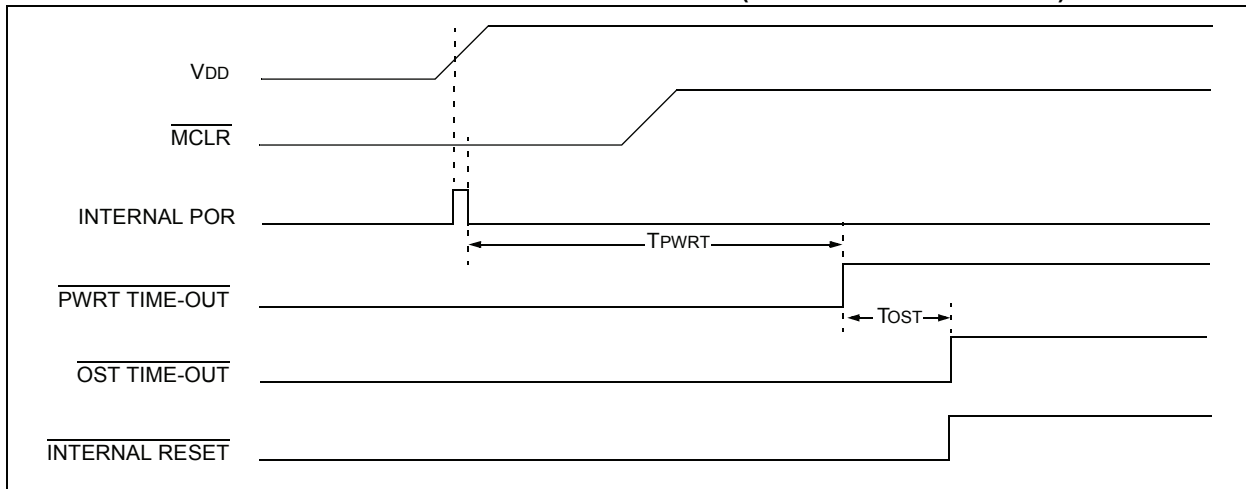
**Note 2:** 2 ms is the nominal time required for the PLL to lock.

# PIC18(L)F1XK22

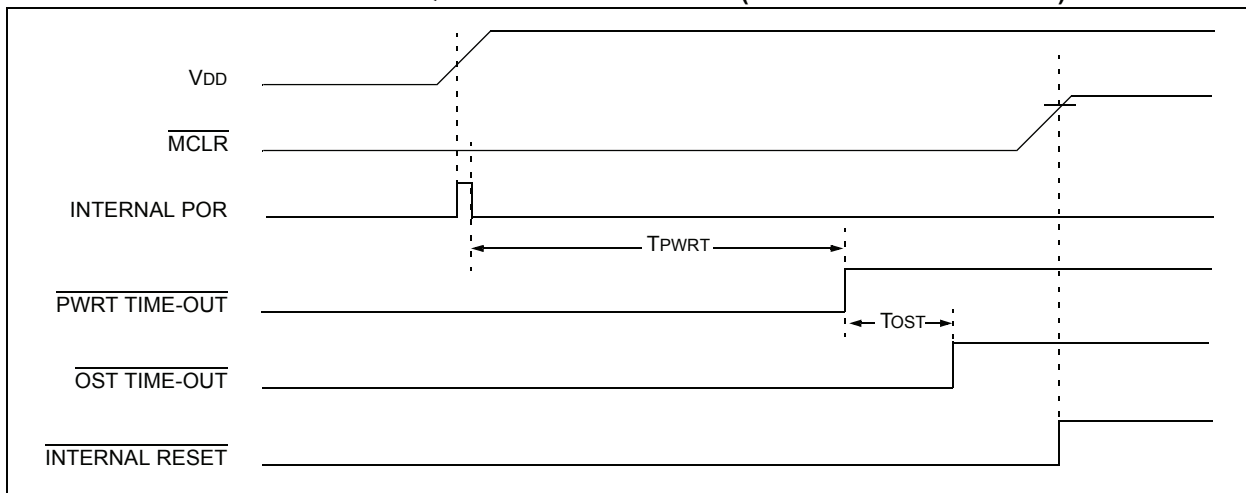
**FIGURE 21-3: TIME-OUT SEQUENCE ON POWER-UP ( $\overline{\text{MCLR}}$  TIED TO  $V_{DD}$ ,  $V_{DD}$  RISE <  $T_{PWRT}$ )**



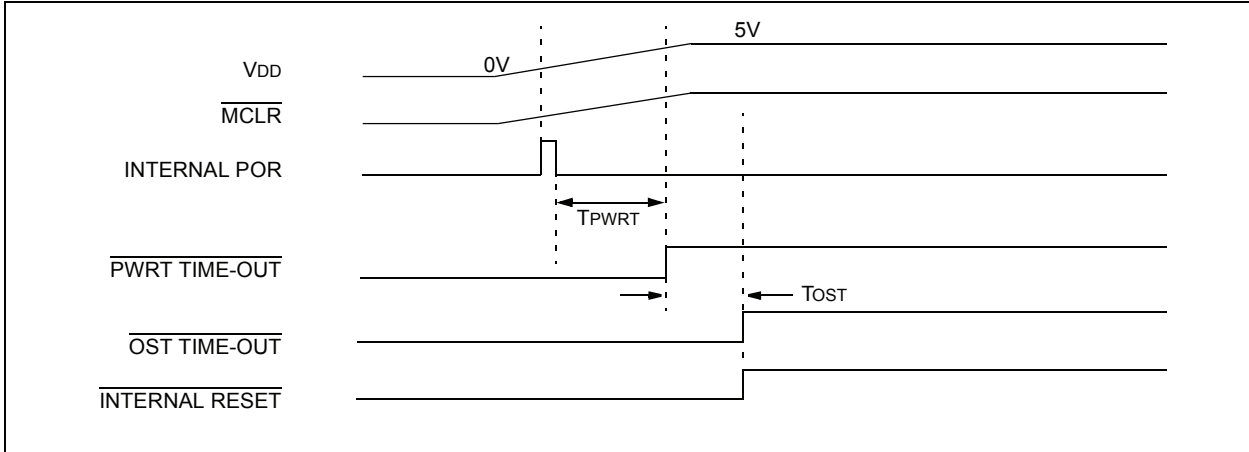
**FIGURE 21-4: TIME-OUT SEQUENCE ON POWER-UP ( $\overline{\text{MCLR}}$  NOT TIED TO  $V_{DD}$ ): CASE 1**



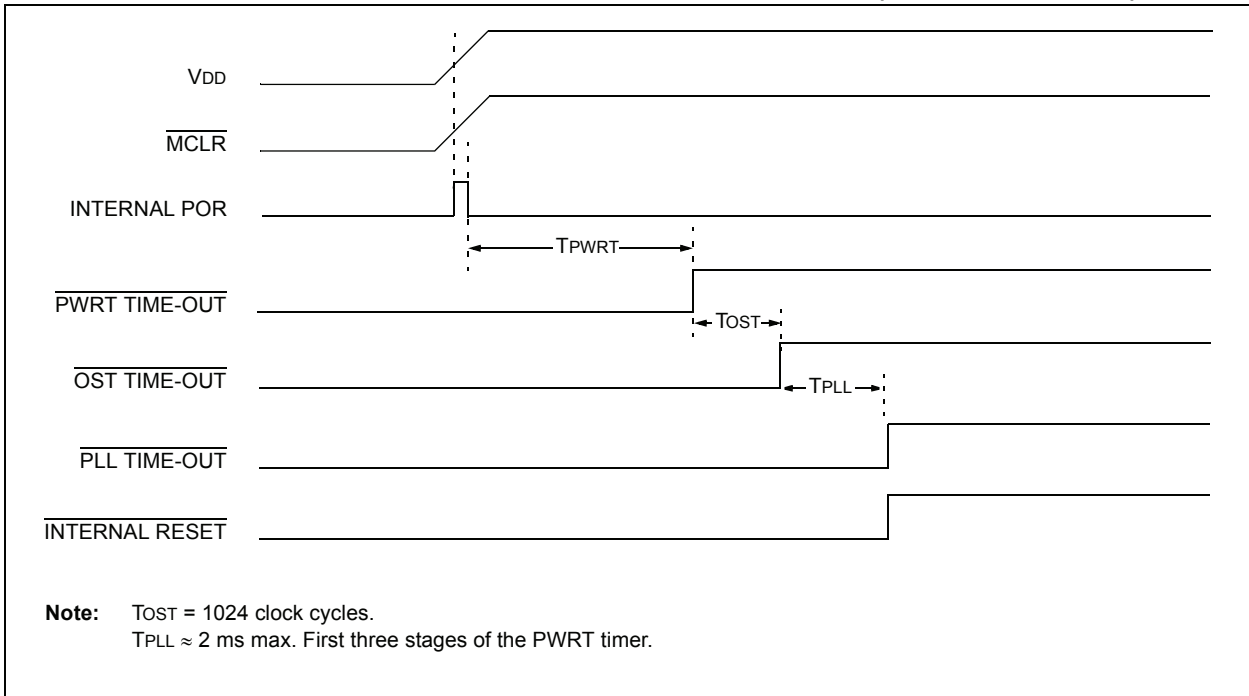
**FIGURE 21-5: TIME-OUT SEQUENCE ON POWER-UP ( $\overline{\text{MCLR}}$  NOT TIED TO  $V_{DD}$ ): CASE 2**



**FIGURE 21-6: SLOW RISE TIME ( $\overline{\text{MCLR}}$  TIED TO  $V_{\text{DD}}$ ,  $V_{\text{DD}}$  RISE  $>$   $T_{\text{PWRT}}$ )**



**FIGURE 21-7: TIME-OUT SEQUENCE ON POR W/PLL ENABLED ( $\overline{\text{MCLR}}$  TIED TO  $V_{\text{DD}}$ )**



# PIC18(L)F1XK22

## 21.6 Reset State of Registers

Some registers are unaffected by a Reset. Their status is unknown on POR and unchanged by all other Resets. All other registers are forced to a “Reset state” depending on the type of Reset that occurred.

Most registers are not affected by a WDT wake-up, since this is viewed as the resumption of normal operation. Status bits from the RCON register,  $\overline{RI}$ ,  $\overline{TO}$ ,  $\overline{PD}$ ,  $\overline{POR}$  and  $\overline{BOR}$ , are set or cleared differently in different Reset situations, as indicated in Table 21-3. These bits are used by software to determine the nature of the Reset.

Table 21-4 describes the Reset states for all of the Special Function Registers. These are categorized by Power-on and Brown-out Resets, Master Clear and WDT Resets and WDT wake-ups.

**TABLE 21-3: STATUS BITS, THEIR SIGNIFICANCE AND THE INITIALIZATION CONDITION FOR RCON REGISTER**

Condition	Program Counter	RCON Register						STKPTR Register	
		SBOREN	$\overline{RI}$	$\overline{TO}$	$\overline{PD}$	$\overline{POR}$	$\overline{BOR}$	STKOVF	STKUNF
Power-on Reset	0000h	1	1	1	1	0	0	0	0
RESET Instruction	0000h	u <sup>(2)</sup>	0	u	u	u	u	u	u
Brown-out Reset	0000h	u <sup>(2)</sup>	1	1	1	u	0	u	u
$\overline{MCLR}$ during Power-Managed Run Modes	0000h	u <sup>(2)</sup>	u	1	u	u	u	u	u
$\overline{MCLR}$ during Power-Managed Idle Modes and Sleep Mode	0000h	u <sup>(2)</sup>	u	1	0	u	u	u	u
WDT Time-out during Full Power or Power-Managed Run Mode	0000h	u <sup>(2)</sup>	u	0	u	u	u	u	u
$\overline{MCLR}$ during Full Power Execution	0000h	u <sup>(2)</sup>	u	u	u	u	u	u	u
Stack Full Reset (STVREN = 1)	0000h	u <sup>(2)</sup>	u	u	u	u	u	1	u
Stack Underflow Reset (STVREN = 1)	0000h	u <sup>(2)</sup>	u	u	u	u	u	u	1
Stack Underflow Error (not an actual Reset, STVREN = 0)	0000h	u <sup>(2)</sup>	u	u	u	u	u	u	1
WDT Time-out during Power-Managed Idle or Sleep Modes	PC + 2	u <sup>(2)</sup>	u	0	0	u	u	u	u
Interrupt Exit from Power-Managed Modes	PC + 2 <sup>(1)</sup>	u <sup>(2)</sup>	u	u	0	u	u	u	u

**Legend:** u = unchanged

**Note 1:** When the wake-up is due to an interrupt and the GIEH or GIEL bits are set, the PC is loaded with the interrupt vector (008h or 0018h).

**2:** Reset state is ‘1’ for POR and unchanged for all other Resets when software BOR is enabled (BOREN<1:0> Configuration bits = 01 and SBOREN = 1). Otherwise, the Reset state is ‘0’.

**TABLE 21-4: INITIALIZATION CONDITIONS FOR ALL REGISTERS**

Register	Address	Power-on Reset, Brown-out Reset	MCLR Resets, WDT Reset, RESET Instruction, Stack Resets	Wake-up via WDT or Interrupt
TOSU	FFFh	---0 0000	---0 0000	---0 uuuu <sup>(3)</sup>
TOSH	FFEh	0000 0000	0000 0000	uuuu uuuu <sup>(3)</sup>
TOSL	FFDh	0000 0000	0000 0000	uuuu uuuu <sup>(3)</sup>
STKPTR	FFCh	00-0 0000	uu-0 0000	uu-u uuuu <sup>(3)</sup>
PCLATU	FFBh	---0 0000	---0 0000	---u uuuu
PCLATH	FFAh	0000 0000	0000 0000	uuuu uuuu
PCL	FF9h	0000 0000	0000 0000	PC + 2 <sup>(2)</sup>
TBLPTRU	FF8h	---0 0000	---0 0000	---u uuuu
TBLPTRH	FF7h	0000 0000	0000 0000	uuuu uuuu
TBLPTRL	FF6h	0000 0000	0000 0000	uuuu uuuu
TABLAT	FF5h	0000 0000	0000 0000	uuuu uuuu
PRODH	FF4h	xxxx xxxx	uuuu uuuu	uuuu uuuu
PRODL	FF3h	xxxx xxxx	uuuu uuuu	uuuu uuuu
INTCON	FF2h	0000 000x	0000 000u	uuuu uuuu <sup>(1)</sup>
INTCON2	FF1h	1111 -1-1	1111 -1-1	uuuu -u-u <sup>(1)</sup>
INTCON3	FF0h	11-0 0-00	11-0 0-00	uu-u u-uu <sup>(1)</sup>
INDF0	FEFh	N/A	N/A	N/A
POSTINC0	FEEh	N/A	N/A	N/A
POSTDEC0	FEDh	N/A	N/A	N/A
PREINC0	FECh	N/A	N/A	N/A
PLUSW0	FEBh	N/A	N/A	N/A
FSR0H	FEAh	---- 0000	---- 0000	---- uuuu
FSR0L	FE9h	xxxx xxxx	uuuu uuuu	uuuu uuuu
WREG	FE8h	xxxx xxxx	uuuu uuuu	uuuu uuuu
INDF1	FE7h	N/A	N/A	N/A
POSTINC1	FE6h	N/A	N/A	N/A
POSTDEC1	FE5h	N/A	N/A	N/A
PREINC1	FE4h	N/A	N/A	N/A
PLUSW1	FE3h	N/A	N/A	N/A

**Legend:** u = unchanged, x = unknown, - = unimplemented bit, read as '0', q = value depends on condition.  
Shaded cells indicate conditions do not apply for the designated device.

- Note 1:** One or more bits in the INTCONx or PIRx registers will be affected (to cause wake-up).  
**2:** When the wake-up is due to an interrupt and the GIEL or GIEH bit is set, the PC is loaded with the interrupt vector (0008h or 0018h).  
**3:** When the wake-up is due to an interrupt and the GIEL or GIEH bit is set, the TOSU, TOSH and TOSL are updated with the current value of the PC. The STKPTR is modified to point to the next location in the hardware stack.  
**4:** See [Table 21-3](#) for Reset value for specific condition.

# PIC18(L)F1XK22

**TABLE 21-4: INITIALIZATION CONDITIONS FOR ALL REGISTERS (CONTINUED)**

Register	Address	Power-on Reset, Brown-out Reset	MCLR Resets, WDT Reset, RESET Instruction, Stack Resets	Wake-up via WDT or Interrupt
FSR1H	FE2h	---- 0000	---- 0000	---- uuuu
FSR1L	FE1h	xxxx xxxx	uuuu uuuu	uuuu uuuu
BSR	FE0h	---- 0000	---- 0000	---- uuuu
INDF2	FDf h	N/A	N/A	N/A
POSTINC2	FDEh	N/A	N/A	N/A
POSTDEC2	FDDh	N/A	N/A	N/A
PREINC2	FDCh	N/A	N/A	N/A
PLUSW2	FDBh	N/A	N/A	N/A
FSR2H	FDAh	---- 0000	---- 0000	---- uuuu
FSR2L	FD9h	xxxx xxxx	uuuu uuuu	uuuu uuuu
STATUS	FD8h	---x xxxx	---u uuuu	---u uuuu
TMR0H	FD7h	0000 0000	0000 0000	uuuu uuuu
TMR0L	FD6h	xxxx xxxx	uuuu uuuu	uuuu uuuu
T0CON	FD5h	1111 1111	1111 1111	uuuu uuuu
OSCCON	FD3h	0011 qq00	0011 qq00	uuuu uuuu
OSCCON2	FD2h	---- -10x	---- -10x	---- -uuu
WDTCON	FD1h	---- ---0	---- ---0	---- ---u
RCON <sup>(4)</sup>	FD0h	0q-1 11q0	0q-q qquu	uq-u qquu
TMR1H	FCFh	xxxx xxxx	uuuu uuuu	uuuu uuuu
TMR1L	FCEh	xxxx xxxx	uuuu uuuu	uuuu uuuu
T1CON	FCDh	0000 0000	u0uu uuuu	uuuu uuuu
TMR2	FCCh	0000 0000	0000 0000	uuuu uuuu
PR2	FCBh	1111 1111	1111 1111	1111 1111
T2CON	FCAh	-000 0000	-000 0000	-uuu uuuu
SSPBUF	FC9h	xxxx xxxx	uuuu uuuu	uuuu uuuu
SSPADD	FC8h	0000 0000	0000 0000	uuuu uuuu
SSPSTAT	FC7h	0000 0000	0000 0000	uuuu uuuu
SSPCON1	FC6h	0000 0000	0000 0000	uuuu uuuu
SSPCON2	FC5h	0000 0000	0000 0000	uuuu uuuu

**Legend:** u = unchanged, x = unknown, - = unimplemented bit, read as '0', q = value depends on condition.

Shaded cells indicate conditions do not apply for the designated device.

- Note 1:** One or more bits in the INTCONx or PIRx registers will be affected (to cause wake-up).
- Note 2:** When the wake-up is due to an interrupt and the GIEL or GIEH bit is set, the PC is loaded with the interrupt vector (0008h or 0018h).
- Note 3:** When the wake-up is due to an interrupt and the GIEL or GIEH bit is set, the TOSU, TOSH and TOSL are updated with the current value of the PC. The STKPTR is modified to point to the next location in the hardware stack.
- Note 4:** See Table 21-3 for Reset value for specific condition.

**TABLE 21-4: INITIALIZATION CONDITIONS FOR ALL REGISTERS (CONTINUED)**

Register	Address	Power-on Reset, Brown-out Reset	MCLR Resets, WDT Reset, RESET Instruction, Stack Resets	Wake-up via WDT or Interrupt
ADRESH	FC4h	xxxx xxxx	uuuu uuuu	uuuu uuuu
ADRESL	FC3h	xxxx xxxx	uuuu uuuu	uuuu uuuu
ADCON0	FC2h	--00 0000	--00 0000	--uu uuuu
ADCON1	FC1h	---- 0000	---- 0000	---- uuuu
ADCON2	FC0h	0-00 0000	0-00 0000	u-uu uuuu
CCPR1H	FBFh	xxxx xxxx	uuuu uuuu	uuuu uuuu
CCPR1L	FBEh	xxxx xxxx	uuuu uuuu	uuuu uuuu
CCP1CON	FBDh	0000 0000	0000 0000	uuuu uuuu
VREFCON2	FBCh	---0 0000	---0 0000	---u uuuu
VREFCON1	FBBh	000- 00-0	000- 00-0	uuu- uu-u
VREFCON0	FBAh	0001 00--	0001 00--	uuuu uu--
PSTRCON	FB9h	---0 0001	---0 0001	---u uuuu
BAUDCON	FB8h	0100 0-00	0100 0-00	uuuu u-uu
PWM1CON	FB7h	0000 0000	0000 0000	uuuu uuuu
ECCP1AS	FB6h	0000 0000	0000 0000	uuuu uuuu
TMR3H	FB3h	xxxx xxxx	uuuu uuuu	uuuu uuuu
TMR3L	FB2h	xxxx xxxx	uuuu uuuu	uuuu uuuu
T3CON	FB1h	0000 0000	uuuu uuuu	uuuu uuuu
SPBRGH	FB0h	0000 0000	0000 0000	uuuu uuuu
SPBRG	FAFh	0000 0000	0000 0000	uuuu uuuu
RCREG	FAEh	0000 0000	0000 0000	uuuu uuuu
TXREG	FADh	0000 0000	0000 0000	uuuu uuuu
TXSTA	FACH	0000 0010	0000 0010	uuuu uuuu
RCSTA	FABh	0000 000x	0000 000x	uuuu uuuu
EEADR	FAAh	0000 0000	0000 0000	uuuu uuuu
EEDATA	FA8h	0000 0000	0000 0000	uuuu uuuu
EECON2	FA7h	0000 0000	0000 0000	0000 0000
EECON1	FA6h	xx-0 x000	uu-0 u000	uu-0 u000

**Legend:** u = unchanged, x = unknown, - = unimplemented bit, read as '0', q = value depends on condition.  
Shaded cells indicate conditions do not apply for the designated device.

- Note 1:** One or more bits in the INTCONx or PIRx registers will be affected (to cause wake-up).  
**Note 2:** When the wake-up is due to an interrupt and the GIEL or GIEH bit is set, the PC is loaded with the interrupt vector (0008h or 0018h).  
**Note 3:** When the wake-up is due to an interrupt and the GIEL or GIEH bit is set, the TOSU, TOSH and TOSL are updated with the current value of the PC. The STKPTR is modified to point to the next location in the hardware stack.  
**Note 4:** See [Table 21-3](#) for Reset value for specific condition.

# PIC18(L)F1XK22

**TABLE 21-4: INITIALIZATION CONDITIONS FOR ALL REGISTERS (CONTINUED)**

Register	Address	Power-on Reset, Brown-out Reset	MCLR Resets, WDT Reset, RESET Instruction, Stack Resets	Wake-up via WDT or Interrupt
IPR2	FA2h	1111 1-1-	1111 1-1-	uuuu u-u-
PIR2	FA1h	0000 0-0-	0000 0-0-	uuuu u-u-(1)
PIE2	FA0h	0000 0-0-	0000 0-0-	uuuu u-u-
IPR1	F9Fh	-111 1111	-111 1111	-uuu uuuu
PIR1	F9Eh	-000 0000	-000 0000	-uuu uuuu(1)
PIE1	F9Dh	-000 0000	-000 0000	-uuu uuuu
OSCTUNE	F9Bh	0000 0000	0000 0000	uuuu uuuu
TRISC	F95h	1111 1111	1111 1111	uuuu uuuu
TRISB	F94h	1111 ----	1111 ----	uuuu ----
TRISA	F93h	--11 1111	--11 1111	--uu uuuu
LATC	F8Bh	xxxx xxxx	uuuu uuuu	uuuu uuuu
LATB	F8Ah	xxxx ----	uuuu ----	uuuu ----
LATA	F89h	--xx xxxx	--uu uuuu	--uu uuuu
PORTC	F82h	xxxx xxxx	uuuu uuuu	uuuu uuuu
PORTB	F81h	xxxx ----	uuuu ----	uuuu ----
PORTA	F80h	--xx xxxx	--xx xxxx	--uu uuuu
ANSELH	F7Fh	---- 1111	---- 1111	---- uuuu
ANSEL	F7Eh	1111 1111	1111 1111	uuuu uuuu
IOCB	F7Ah	0000 ----	0000 ----	uuuu ----
IOCA	F79h	--00 0000	--00 0000	--uu uuuu
WPUB	F78h	1111 ----	1111 ----	uuuu ----
WPUA	F77h	--11 1111	--11 1111	--uu uuuu
SLRCON	F76h	---- -111	---- -111	---- -uuu
SSPMSK	F6Fh	1111 1111	1111 1111	uuuu uuuu
CM1CON0	F6Dh	0000 0000	0000 0000	uuuu uuuu
CM2CON1	F6Ch	0000 0000	0000 0000	uuuu uuuu
CM2CON0	F6Bh	0000 0000	0000 0000	uuuu uuuu
SRCON1	F69h	0000 0000	0000 0000	uuuu uuuu
SRCON0	F68h	0000 0000	0000 0000	uuuu uuuu

**Legend:** u = unchanged, x = unknown, - = unimplemented bit, read as '0', q = value depends on condition.  
Shaded cells indicate conditions do not apply for the designated device.

- Note 1:** One or more bits in the INTCONx or PIRx registers will be affected (to cause wake-up).  
**Note 2:** When the wake-up is due to an interrupt and the GIEL or GIEH bit is set, the PC is loaded with the interrupt vector (0008h or 0018h).  
**Note 3:** When the wake-up is due to an interrupt and the GIEL or GIEH bit is set, the TOSU, TOSH and TOSL are updated with the current value of the PC. The STKPTR is modified to point to the next location in the hardware stack.  
**Note 4:** See Table 21-3 for Reset value for specific condition.



## 22.0 SPECIAL FEATURES OF THE CPU

PIC18(L)F1XK22 devices include several features intended to maximize reliability and minimize cost through elimination of external components. These are:

- Oscillator Selection
- Resets:
  - Power-on Reset (POR)
  - Power-up Timer (PWRT)
  - Oscillator Start-up Timer (OST)
  - Brown-out Reset (BOR)
- Interrupts
- Watchdog Timer (WDT)
- Code Protection
- ID Locations
- In-Circuit Serial Programming™

The oscillator can be configured for the application depending on frequency, power, accuracy and cost. All of the options are discussed in detail in [Section 2.0 “Oscillator Module”](#).

A complete discussion of device Resets and interrupts is available in previous sections of this data sheet.

In addition to their Power-up and Oscillator Start-up Timers provided for Resets, PIC18(L)F1XK22 devices have a Watchdog Timer, which is either permanently enabled via the Configuration bits or software controlled (if configured as disabled).

The inclusion of an internal RC oscillator also provides the additional benefits of a Fail-Safe Clock Monitor (FSCM) and Two-Speed Start-up. FSCM provides for background monitoring of the peripheral clock and automatic switchover in the event of its failure. Two-Speed Start-up enables code to be executed almost immediately on start-up, while the primary clock source completes its start-up delays.

All of these features are enabled and configured by setting the appropriate Configuration register bits.

# PIC18(L)F1XK22

## 22.1 Configuration Bits

The Configuration bits can be programmed (read as '0') or left unprogrammed (read as '1') to select various device configurations. These bits are mapped starting at program memory location 300000h.

The user will note that address 300000h is beyond the user program memory space. In fact, it belongs to the configuration memory space (300000h-3FFFFFFh), which can only be accessed using table reads and table writes.

Programming the Configuration registers is done in a manner similar to programming the Flash memory. The WR bit in the EECON1 register starts a self-timed write to the Configuration register. In normal operation mode, a TBLWT instruction with the TBLPTR pointing to the Configuration register sets up the address and the data for the Configuration register write. Setting the WR bit starts a long write to the Configuration register. The Configuration registers are written a byte at a time. To write or erase a configuration cell, a TBLWT instruction can write a '1' or a '0' into the cell. For additional details on Flash programming, refer to [Section 4.5 "Writing to Flash Program Memory"](#).

**TABLE 22-1: CONFIGURATION BITS AND DEVICE IDs**

File Name	Bit 7	Bit 6	Bit 5	Bit 4	Bit 3	Bit 2	Bit 1	Bit 0	Default/ Unprogrammed Value
300001h CONFIG1H	IESO	FCMEN	PCLKEN	PLL_EN	FOSC3	FOSC2	FOSC1	FOSC0	0010 0111
300002h CONFIG2L	—	—	—	BORV1	BORV0	BOREN1	BOREN0	PWRTE $\bar{n}$	---1 1111
300003h CONFIG2H	—	—	—	WDTPS3	WDTPS2	WDTPS1	WDTPS0	WDTEN	---1 1111
300005h CONFIG3H	MCLR $\bar{E}$	—	—	—	HFOFST	—	—	—	1--- 1---
300006h CONFIG4L	BKBUG $\bar{B}$	ENHCPU	—	—	BBSIZ	LVP	—	STVREN	-0-- 01-1
300008h CONFIG5L	—	—	—	—	—	—	CP1	CP0	---- --11
300009h CONFIG5H	CPD	CPB	—	—	—	—	—	—	11-- ----
30000Ah CONFIG6L	—	—	—	—	—	—	WRT1	WRT0	---- --11
30000Bh CONFIG6H	WRTE $\bar{n}$	WRTB	WRTE $\bar{n}$	—	—	—	—	—	111- ----
30000Ch CONFIG7L	—	—	—	—	—	—	EBTR1	EBTR0	---- --11
30000Dh CONFIG7H	—	EBTRB	—	—	—	—	—	—	-1-- ----
3FFFFFFEh DEVID1 <sup>(1)</sup>	DEV2	DEV1	DEV0	REV4	REV3	REV2	REV1	REV0	qqqq qq <sup>(1)</sup>
3FFFFFFFh DEVID2 <sup>(1)</sup>	DEV10	DEV9	DEV8	DEV7	DEV6	DEV5	DEV4	DEV3	0000 1100

**Legend:** x = unknown, u = unchanged, — = unimplemented,  $\alpha$  = value depends on condition.  
Shaded cells are unimplemented, read as '0'

**Note 1:** See [Register 22-12](#) for DEVID1 values. DEVID registers are read-only and cannot be programmed by the user.

## REGISTER 22-1: CONFIG1H: CONFIGURATION REGISTER 1 HIGH

R/P-0	R/P-0	R/P-1	R/P-0	R/P-0	R/P-1	R/P-1	R/P-1
IESO	FCMEN	PCLKEN	PLL_EN	FOSC3	FOSC2	FOSC1	FOSC0
bit 7							bit 0

### Legend:

R = Readable bit                      P = Programmable bit                      U = Unimplemented bit, read as '0'  
 -n = Value when device is unprogrammed                      x = Bit is unknown

- bit 7            **IESO**: Internal/External Oscillator Switchover bit  
                   1 = Oscillator Switchover mode enabled  
                   0 = Oscillator Switchover mode disabled
- bit 6            **FCMEN**: Fail-Safe Clock Monitor Enable bit  
                   1 = Fail-Safe Clock Monitor enabled  
                   0 = Fail-Safe Clock Monitor disabled
- bit 5            **PCLKEN**: Primary Clock Enable bit  
                   1 = Primary Clock enabled  
                   0 = Primary Clock is under software control
- bit 4            **PLL\_EN**: 4 X PLL Enable bit  
                   1 = Oscillator multiplied by 4  
                   0 = PLL is under software control
- bit 3-0        **FOSC<3:0>**: Oscillator Selection bits  
                   1111 = External RC oscillator, CLKOUT function on OSC2  
                   1110 = External RC oscillator, CLKOUT function on OSC2  
                   1101 = EC (low)  
                   1100 = EC, CLKOUT function on OSC2 (low)  
                   1011 = EC (medium)  
                   1010 = EC, CLKOUT function on OSC2 (medium)  
                   1001 = Internal RC oscillator, CLKOUT function on OSC2  
                   1000 = Internal RC oscillator  
                   0111 = External RC oscillator  
                   0110 = External RC oscillator, CLKOUT function on OSC2  
                   0101 = EC (high)  
                   0100 = EC, CLKOUT function on OSC2 (high)  
                   0011 = External RC oscillator, CLKOUT function on OSC2  
                   0010 = HS oscillator  
                   0001 = XT oscillator  
                   0000 = LP oscillator

# PIC18(L)F1XK22

## REGISTER 22-2: CONFIG2L: CONFIGURATION REGISTER 2 LOW

U-0	U-0	U-0	R/P-1	R/P-1	R/P-1	R/P-1	R/P-1
—	—	—	BORV1 <sup>(1)</sup>	BORV0 <sup>(1)</sup>	BOREN1 <sup>(2)</sup>	BOREN0 <sup>(2)</sup>	PWRTEN <sup>(2)</sup>
bit 7							bit 0

### Legend:

R = Readable bit                      P = Programmable bit                      U = Unimplemented bit, read as '0'  
 -n = Value when device is unprogrammed                      x = Bit is unknown

bit 7-5                      **Unimplemented:** Read as '0'

bit 4-3                      **BORV<1:0>:** Brown-out Reset Voltage bits<sup>(1)</sup>

11 = VBOR set to 1.9V nominal

10 = VBOR set to 2.2V nominal

01 = VBOR set to 2.5V nominal

00 = VBOR set to 2.85V nominal

bit 2-1                      **BOREN<1:0>:** Brown-out Reset Enable bits<sup>(2)</sup>

11 = Brown-out Reset enabled in hardware only (SBOREN is disabled)

10 = Brown-out Reset enabled in hardware only and disabled in Sleep mode (SBOREN is disabled)

01 = Brown-out Reset enabled and controlled by software (SBOREN is enabled)

00 = Brown-out Reset disabled in hardware and software

bit 0                      **PWRTEN:** Power-up Timer Enable bit<sup>(2)</sup>

1 = PWRT disabled

0 = PWRT enabled

**Note 1:** See Section 26.1 "DC Characteristics: Supply Voltage" for specifications.

**Note 2:** The Power-up Timer is decoupled from Brown-out Reset, allowing these features to be independently controlled.

## REGISTER 22-3: CONFIG2H: CONFIGURATION REGISTER 2 HIGH

U-0	U-0	U-0	R/P-1	R/P-1	R/P-1	R/P-1	R/P-1	
—	—	—	WDTPS3	WDTPS2	WDTPS1	WDTPS0	WDTEN	
bit 7								bit 0

### Legend:

R = Readable bit                      P = Programmable bit                      U = Unimplemented bit, read as '0'  
 -n = Value when device is unprogrammed                      x = Bit is unknown

bit 7-5                      **Unimplemented:** Read as '0'

bit 4-1                      **WDTPS<3:0>:** Watchdog Timer Postscale Select bits

1111 = 1:32,768  
 1110 = 1:16,384  
 1101 = 1:8,192  
 1100 = 1:4,096  
 1011 = 1:2,048  
 1010 = 1:1,024  
 1001 = 1:512  
 1000 = 1:256  
 0111 = 1:128  
 0110 = 1:64  
 0101 = 1:32  
 0100 = 1:16  
 0011 = 1:8  
 0010 = 1:4  
 0001 = 1:2  
 0000 = 1:1

bit 0                      **WDTEN:** Watchdog Timer Enable bit

1 = WDT is always enabled. SWDTEN bit has no effect  
 0 = WDT is controlled by SWDTEN bit of the WDTCON register

# PIC18(L)F1XK22

## REGISTER 22-4: CONFIG3H: CONFIGURATION REGISTER 3 HIGH

R/P-1	U-0	U-0	U-0	R/P-1	U-0	U-0	U-0
MCLRE	—	—	—	HFOFST	—	—	—
bit 7							bit 0

### Legend:

R = Readable bit                      P = Programmable bit                      U = Unimplemented bit, read as '0'  
 -n = Value when device is unprogrammed                      x = Bit is unknown

- bit 7                      **MCLRE:**  $\overline{\text{MCLR}}$  Pin Enable bit  
 1 =  $\overline{\text{MCLR}}$  pin enabled; RA3 input pin disabled  
 0 = RA3 input pin enabled;  $\overline{\text{MCLR}}$  disabled
- bit 6-4                      **Unimplemented:** Read as '0'
- bit 3                      **HFOFST:** HFINTOSC Fast Start-up bit  
 1 = HFINTOSC starts clocking the CPU without waiting for the oscillator to stabilize.  
 0 = The system clock is held off until the HFINTOSC is stable.
- bit 2-0                      **Unimplemented:** Read as '0'

## REGISTER 22-5: CONFIG4L: CONFIGURATION REGISTER 4 LOW

R/W-1 <sup>(1)</sup>	R/W-0	U-0	U-0	R/P-0	R/P-1	U-0	R/P-1
$\overline{\text{BKBUG}}$	ENHCPU	—	—	BBSIZ	LVP	—	STVREN
bit 7							bit 0

### Legend:

R = Readable bit                      P = Programmable bit                      U = Unimplemented bit, read as '0'  
 -n = Value when device is unprogrammed                      x = Bit is unknown

- bit 7                      **BKBUG:** Background Debugger Enable bit<sup>(1)</sup>  
 1 = Background Debugger disabled  
 0 = Background Debugger functions enabled
- bit 6                      **ENHCPU:** Enhanced CPU Enable bit  
 1 = Enhanced CPU enabled  
 0 = Enhanced CPU disabled
- bit 5-4                      **Unimplemented:** Read as '0'
- bit 3                      **BBSIZ:** Boot BLock Size Select bit  
 1 = 2 kW boot block size for PIC18(L)F14K22 (1 kW boot block size for PIC18(L)F13K22)  
 0 = 1 kW boot block size for PIC18(L)F14K22 (512 W boot block size for PIC18(L)F13K22)
- bit 2                      **LVP:** Single-Supply ICSP™ Enable bit  
 1 = Single-Supply ICSP enabled  
 0 = Single-Supply ICSP disabled
- bit 1                      **Unimplemented:** Read as '0'
- bit 0                      **STVREN:** Stack Full/Underflow Reset Enable bit  
 1 = Stack full/underflow will cause Reset  
 0 = Stack full/underflow will not cause Reset

**Note 1:**  $\overline{\text{BKBUG}}$  is only used for ICD device. Otherwise, this bit is unimplemented and reads as '1'.

## REGISTER 22-6: CONFIG5L: CONFIGURATION REGISTER 5 LOW

U-0	U-0	U-0	U-0	U-0	U-0	R/C-1	R/C-1
—	—	—	—	—	—	CP1	CP0
bit 7						bit 0	

### Legend:

R = Readable bit

U = Unimplemented bit, read as '0'

-n = Value when device is unprogrammed

C = Clearable only bit

bit 7-2      **Unimplemented:** Read as '0'

bit 1      **CP1:** Code Protection bit  
 1 = Block 1 not code-protected  
 0 = Block 1 code-protected

bit 0      **CP0:** Code Protection bit  
 1 = Block 0 not code-protected  
 0 = Block 0 code-protected

## REGISTER 22-7: CONFIG5H: CONFIGURATION REGISTER 5 HIGH

R/C-1	R/C-1	U-0	U-0	U-0	U-0	U-0	U-0
CPD	CPB	—	—	—	—	—	—
bit 7						bit 0	

### Legend:

R = Readable bit

U = Unimplemented bit, read as '0'

-n = Value when device is unprogrammed

C = Clearable only bit

bit 7      **CPD:** Data EEPROM Code Protection bit  
 1 = Data EEPROM not code-protected  
 0 = Data EEPROM code-protected

bit 6      **CPB:** Boot Block Code Protection bit  
 1 = Boot block not code-protected  
 0 = Boot block code-protected

bit 5-0      **Unimplemented:** Read as '0'

# PIC18(L)F1XK22

## REGISTER 22-8: CONFIG6L: CONFIGURATION REGISTER 6 LOW

U-0	U-0	U-0	U-0	U-0	U-0	R/C-1	R/C-1
—	—	—	—	—	—	WRT1	WRT0
bit 7							bit 0

### Legend:

R = Readable bit

U = Unimplemented bit, read as '0'

-n = Value when device is unprogrammed

C = Clearable only bit

bit 7-2 **Unimplemented:** Read as '0'

bit 1 **WRT1:** Write Protection bit  
 1 = Block 1 not write-protected  
 0 = Block 1 write-protected

bit 0 **WRT0:** Write Protection bit  
 1 = Block 0 not write-protected  
 0 = Block 0 write-protected

## REGISTER 22-9: CONFIG6H: CONFIGURATION REGISTER 6 HIGH

R/C-1	R/C-1	R-1	U-0	U-0	U-0	U-0	U-0
WRTD	WRTB	WRTC <sup>(1)</sup>	—	—	—	—	—
bit 7							bit 0

### Legend:

R = Readable bit

U = Unimplemented bit, read as '0'

-n = Value when device is unprogrammed

C = Clearable only bit

bit 7 **WRTD:** Data EEPROM Write Protection bit  
 1 = Data EEPROM not write-protected  
 0 = Data EEPROM write-protected

bit 6 **WRTB:** Boot Block Write Protection bit  
 1 = Boot block not write-protected  
 0 = Boot block write-protected

bit 5 **WRTC:** Configuration Register Write Protection bit<sup>(1)</sup>  
 1 = Configuration registers not write-protected  
 0 = Configuration registers write-protected

bit 4-0 **Unimplemented:** Read as '0'

**Note 1:** This bit is read-only in normal execution mode; it can be written only in Program mode.



## REGISTER 22-10: CONFIG7L: CONFIGURATION REGISTER 7 LOW

U-0	U-0	U-0	U-0	U-0	U-0	R/C-1	R/C-1
—	—	—	—	—	—	EBTR1	EBTR0
bit 7						bit 0	

### Legend:

R = Readable bit

U = Unimplemented bit, read as '0'

-n = Value when device is unprogrammed

C = Clearable only bit

bit 7-2      **Unimplemented:** Read as '0'

bit 1      **EBTR1:** Table Read Protection bit

1 = Block 1 not protected from table reads executed in other blocks

0 = Block 1 protected from table reads executed in other blocks

bit 0      **EBTR0:** Table Read Protection bit

1 = Block 0 not protected from table reads executed in other blocks

0 = Block 0 protected from table reads executed in other blocks

## REGISTER 22-11: CONFIG7H: CONFIGURATION REGISTER 7 HIGH

U-0	R/C-1	U-0	U-0	U-0	U-0	U-0	U-0
—	EBTRB	—	—	—	—	—	—
bit 7						bit 0	

### Legend:

R = Readable bit

U = Unimplemented bit, read as '0'

-n = Value when device is unprogrammed

C = Clearable only bit

bit 7      **Unimplemented:** Read as '0'

bit 6      **EBTRB:** Boot Block Table Read Protection bit

1 = Boot block not protected from table reads executed in other blocks

0 = Boot block protected from table reads executed in other blocks

bit 5-0      **Unimplemented:** Read as '0'

# PIC18(L)F1XK22

## REGISTER 22-12: DEVID1: DEVICE ID REGISTER 1 FOR PIC18(L)F1XK22

R	R	R	R	R	R	R	R
DEV2	DEV1	DEV0	REV4	REV3	REV2	REV1	REV0
bit 7							bit 0

### Legend:

R = Readable bit

U = Unimplemented bit, read as '0'

-n = Value when device is unprogrammed

C = Clearable only bit

bit 7-5 **DEV<2:0>**: Device ID bits

010 = PIC18(L)F13K22

011 = PIC18(L)F14K22

bit 4-0 **REV<4:0>**: Revision ID bits

These bits are used to indicate the device revision.

## REGISTER 22-13: DEVID2: DEVICE ID REGISTER 2 FOR PIC18(L)F1XK22

R	R	R	R	R	R	R	R
DEV10	DEV9	DEV8	DEV7	DEV6	DEV5	DEV4	DEV3
bit 7							bit 0

### Legend:

R = Readable bit

U = Unimplemented bit, read as '0'

-n = Value when device is unprogrammed

C = Clearable only bit

bit 7-0 **DEV<10:3>**: Device ID bits

These bits are used with the DEV<2:0> bits in the Device ID Register 1 to identify the part number.

0010 0000 = PIC18F13K22/PIC18F14K22 devices

**Note 1:** These values for DEV<10:3> may be shared with other devices. The specific device is always identified by using the entire DEV<10:0> bit sequence.

## 22.2 Watchdog Timer (WDT)

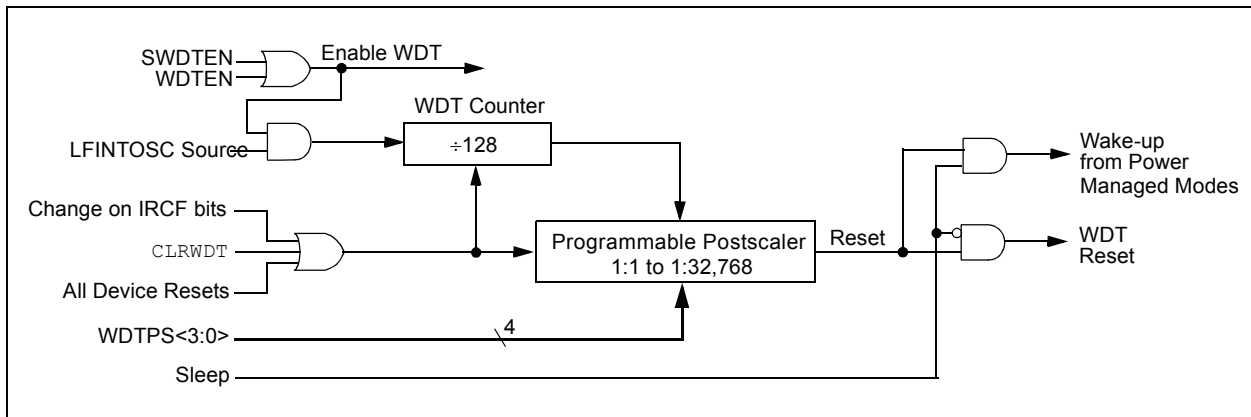
For PIC18(L)F1XK22 devices, the WDT is driven by the LFINTOSC source. When the WDT is enabled, the clock source is also enabled. The nominal WDT period is 4ms and has the same stability as the LFINTOSC oscillator.

The 4ms period of the WDT is multiplied by a 16-bit postscaler. Any output of the WDT postscaler is selected by a multiplexer, controlled by bits in Configuration register 2H. Available periods range from 4ms to 131.072 seconds (2.18 minutes). The WDT and postscaler are cleared when any of the following events occur: a `SLEEP` or `CLRWDT` instruction is executed, the IRCF bits of the OSCCON register are changed or a clock failure has occurred.

**Note 1:** The `CLRWDT` and `SLEEP` instructions clear the WDT and postscaler counts when executed.

**2:** Changing the setting of the IRCF bits of the OSCCON register clears the WDT and postscaler counts.

**FIGURE 22-1: WDT BLOCK DIAGRAM**



# PIC18(L)F1XK22

## 22.2.1 CONTROL REGISTER

Register 22-14 shows the WDTCON register. This is a readable and writable register which contains a control bit that allows software to override the WDT enable Configuration bit, but only if the Configuration bit has disabled the WDT.

**REGISTER 22-14: WDTCON: WATCHDOG TIMER CONTROL REGISTER**

U-0	U-0	U-0	U-0	U-0	U-0	U-0	R/W-0
—	—	—	—	—	—	—	SWDTEN <sup>(1)</sup>
bit 7							bit 0

**Legend:**

R = Readable bit	W = Writable bit	U = Unimplemented bit, read as '0'
-n = Value at POR	'1' = Bit is set	'0' = Bit is cleared
		x = Bit is unknown

bit 7-1      **Unimplemented:** Read as '0'

bit 0      **SWDTEN:** Software Enable or Disable the Watchdog Timer bit<sup>(1)</sup>  
             1 = WDT is turned on  
             0 = WDT is turned off (Reset value)

**Note 1:** This bit has no effect if the Configuration bit, WDTEEN, is enabled.

**TABLE 22-2: SUMMARY OF WATCHDOG TIMER REGISTERS**

Name	Bit 7	Bit 6	Bit 5	Bit 4	Bit 3	Bit 2	Bit 1	Bit 0	Reset Values on page
CONFIG2H	—	—	—	WDTPS3	WDTPS2	WDTPS1	WDTPS0	WDTEN	261
RCON	IPEN	SBOREN	—	RI	TO	PD	POR	BOR	254
WDTCON	—	—	—	—	—	—	—	SWDTEN	254

**Legend:** — = unimplemented, read as '0'. Shaded cells are not used by the Watchdog Timer.

## 22.3 Program Verification and Code Protection

The overall structure of the code protection on the PIC18 Flash devices differs significantly from other PIC<sup>®</sup> microcontroller devices.

The user program memory is divided into five blocks. One of these is a boot block of 0.5K or 2K bytes, depending on the device. The remainder of the memory is divided into individual blocks on binary boundaries.

Each of the five blocks has three code protection bits associated with them. They are:

- Code-Protect bit (CPn)
- Write-Protect bit (WRTn)
- External Block Table Read bit (EBTRn)

Figure 22-2 shows the program memory organization for 8, 16 and 32-Kbyte devices and the specific code protection bit associated with each block. The actual locations of the bits are summarized in Table 22-3.

# PIC18(L)F1XK22

**FIGURE 22-2: CODE-PROTECTED PROGRAM MEMORY FOR PIC18(L)F1XK22**

Address (from/to)	Device			
	14K22		13K22	
	BBSIZ = 1	BBSIZ = 0	BBSIZ = 1	BBSIZ = 0
0000h 03FFh	Boot Block, 4 KB CPB, WRTB, EBTRB	Boot Block, 2 KB CPB, WRTB, EBTRB	Boot Block, 2 KB CPB, WRTB, EBTRB	Boot Block, 1 KB CPB, WRTB, EBTRB
0400h 07FFh				Block 0 1.512 KB CP0, WRT0, EBTR0
0800h 0BFFh				
0C00h 0FFFh				
1000h 1FFFh	Block 0 4 KB CP0, WRT0, EBTR0	Block 0 6 KB CP0, WRT0, EBTR0	Block 0 2 KB CP0, WRT0, EBTR0	Block 1 4 KB CP1, WRT1, EBTR1
2000h 3FFFh	Block 1 8 KB CP1, WRT1, EBTR1		Block 1 8 KB CP1, WRT1, EBTR1	
4000h 4FFEh	Reads all '0's	Reads all '0's	Reads all '0's	Reads all '0's
5000h 5FFEh				
6000h 6FFEh				
7000h 7FFEh				
8000h 8FFEh				
9000h 9FFEh				
A000h AFFEh				
B000h BFFEh				
C000h CFFEh				
D000h DFFEh				
E000h EFFEh				
F000h FFFEh				
H000h HFFEh				

**Note:** Refer to the test section for requirements on test memory mapping.

# PIC18(L)F1XK22

**TABLE 22-3: SUMMARY OF CODE PROTECTION REGISTERS**

File Name		Bit 7	Bit 6	Bit 5	Bit 4	Bit 3	Bit 2	Bit 1	Bit 0
300008h	CONFIG5L	—	—	—	—	—	—	CP1	CP0
300009h	CONFIG5H	CPD	CPB	—	—	—	—	—	—
30000Ah	CONFIG6L	—	—	—	—	—	—	WRT1	WRT0
30000Bh	CONFIG6H	WRD	WRTB	WRTC	—	—	—	—	—
30000Ch	CONFIG7L	—	—	—	—	—	—	EBTR1	EBTR0
30000Dh	CONFIG7H	—	EBTRB	—	—	—	—	—	—

**Legend:** Shaded cells are unimplemented.

**Note 1:** Unimplemented in PIC18FX3K20 and PIC18FX4K20 devices; maintain this bit set.

## 22.3.1 PROGRAM MEMORY CODE PROTECTION

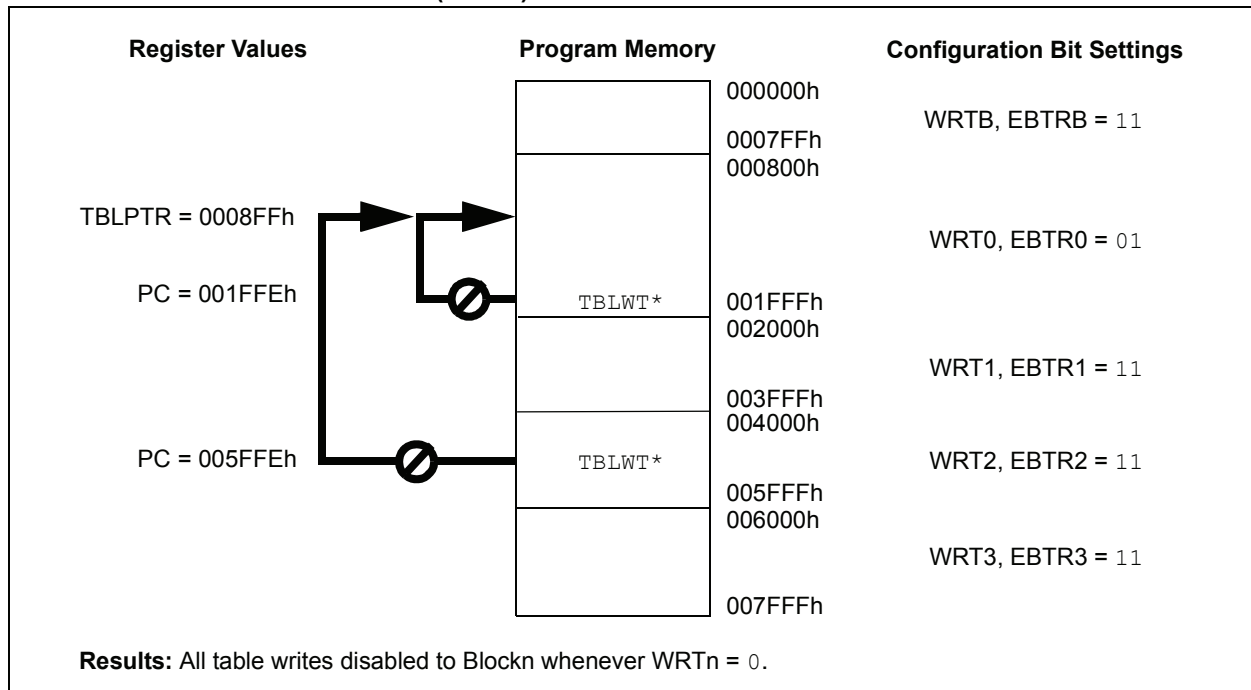
The program memory may be read to or written from any location using the table read and table write instructions. The device ID may be read with table reads. The Configuration registers may be read and written with the table read and table write instructions.

In normal execution mode, the CPn bits have no direct effect. CPn bits inhibit external reads and writes. A block of user memory may be protected from table writes if the WRTn Configuration bit is '0'. The EBTRn bits control table reads. For a block of user memory with the EBTRn bit cleared to '0', a table READ instruction that executes from within that block is allowed to read. A table read

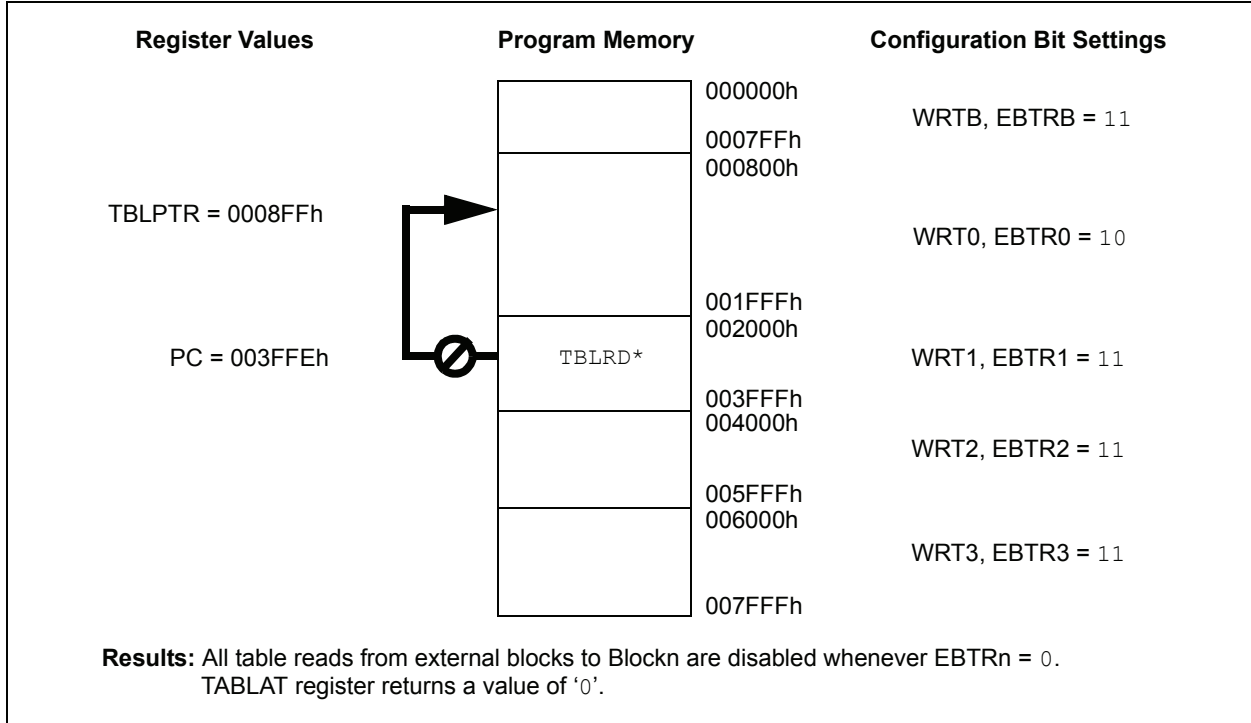
instruction that executes from a location outside of that block is not allowed to read and will result in reading '0's. Figures 22-3 through 22-5 illustrate table write and table read protection.

**Note:** Code protection bits may only be written to a '0' from a '1' state. It is not possible to write a '1' to a bit in the '0' state. Code protection bits are only set to '1' by a full chip erase or block erase function. The full chip erase and block erase functions can only be initiated via ICSP or an external programmer.

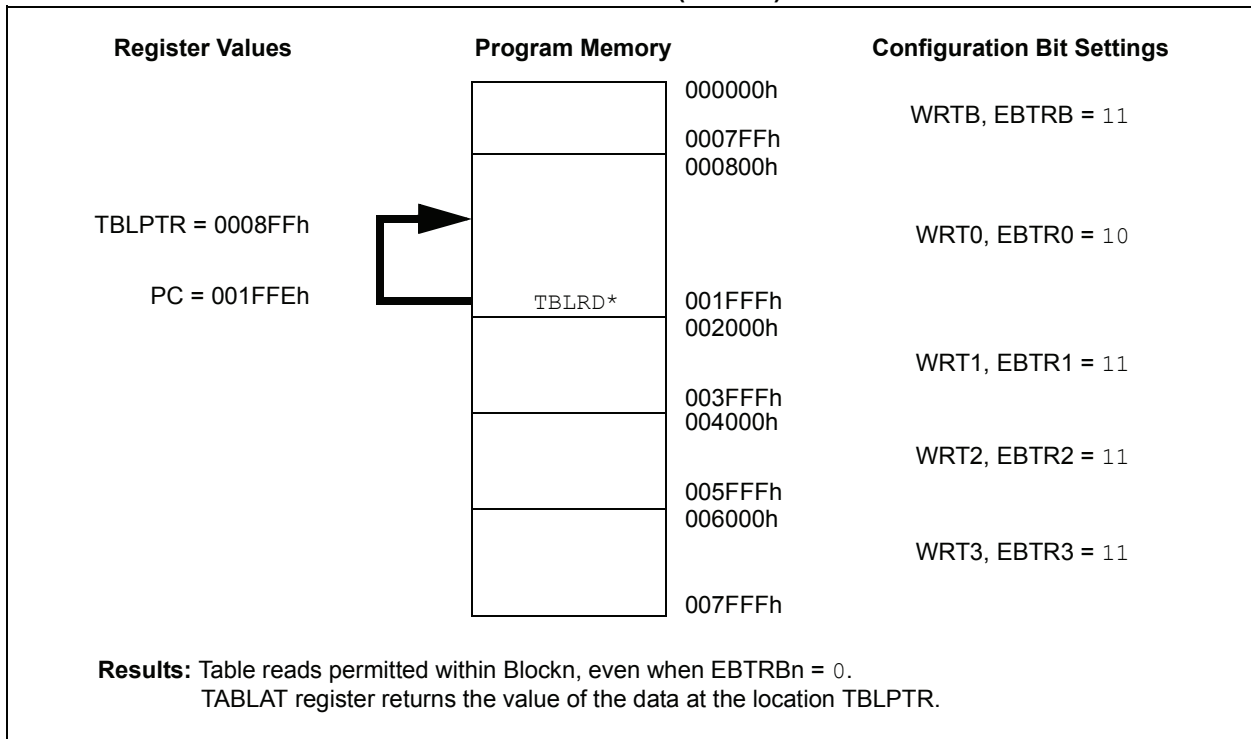
**FIGURE 22-3: TABLE WRITE (WRTn) DISALLOWED**



**FIGURE 22-4: EXTERNAL BLOCK TABLE READ (EBTRn) DISALLOWED**



**FIGURE 22-5: EXTERNAL BLOCK TABLE READ (EBTRn) ALLOWED**



# PIC18(L)F1XK22

## 22.3.2 DATA EEPROM CODE PROTECTION

The entire data EEPROM is protected from external reads and writes by two bits: CPD and WRTD. CPD inhibits external reads and writes of data EEPROM. WRTD inhibits internal and external writes to data EEPROM. The CPU can always read data EEPROM under normal operation, regardless of the protection bit settings.

## 22.3.3 CONFIGURATION REGISTER PROTECTION

The Configuration registers can be write-protected. The WRTC bit controls protection of the Configuration registers. In normal execution mode, the WRTC bit is readable only. WRTC can only be written via ICSP or an external programmer.

## 22.4 ID Locations

Eight memory locations (200000h-200007h) are designated as ID locations, where the user can store checksum or other code identification numbers. These locations are both readable and writable during normal execution through the TBLRD and TBLWT instructions or during program/verify. The ID locations can be read when the device is code-protected.

## 22.5 In-Circuit Serial Programming

PIC18(L)F1XK22 devices can be serially programmed while in the end application circuit. This is simply done with two lines for clock and data and three other lines for power, ground and the programming voltage. This allows customers to manufacture boards with unprogrammed devices and then program the microcontroller just before shipping the product. This also allows the most recent firmware or a custom firmware to be programmed.

## 22.6 In-Circuit Debugger

When the DEBUG Configuration bit is programmed to a '0', the In-Circuit Debugger functionality is enabled. This function allows simple debugging functions when used with MPLAB® IDE. When the microcontroller has this feature enabled, some resources are not available for general use. Table 22-4 shows which resources are required by the background debugger.

**TABLE 22-4: DEBUGGER RESOURCES**

I/O pins:	RA0, RA1
Stack:	2 levels
Program Memory:	512 bytes
Data Memory:	10 bytes

To use the In-Circuit Debugger function of the microcontroller, the design must implement In-Circuit Serial Programming connections to the following pins:

- MCLR/VPP/RA3
- VDD
- VSS
- RA0
- RA1

This will interface to the In-Circuit Debugger module available from Microchip or one of the third party development tool companies.

## 22.7 Single-Supply ICSP Programming

The LVP Configuration bit enables Single-Supply ICSP Programming (formerly known as Low-Voltage ICSP Programming or LVP). When Single-Supply Programming is enabled, the microcontroller can be programmed without requiring high voltage being applied to the MCLR/VPP/RA3 pin, but the RC3/PGM pin is then dedicated to controlling Program mode entry and is not available as a general purpose I/O pin.

While programming, using Single-Supply Programming mode, VDD is applied to the MCLR/VPP/RA3 pin as in normal execution mode. To enter Programming mode, VDD is applied to the PGM pin.

- Note 1:** High-voltage programming is always available, regardless of the state of the LVP bit or the PGM pin, by applying VIH to the MCLR pin.
- 2:** By default, Single-Supply ICSP is enabled in unprogrammed devices (as supplied from Microchip) and erased devices.
- 3:** When Single-Supply Programming is enabled, the RC3 pin can no longer be used as a general purpose I/O pin.
- 4:** When LVP is enabled, externally pull the PGM pin to VSS to allow normal program execution.

If Single-Supply ICSP Programming mode will not be used, the LVP bit can be cleared. RC3/PGM then becomes available as the digital I/O pin, RC3. The LVP bit may be set or cleared only when using standard high-voltage programming (VIH applied to the MCLR/VPP/RA3 pin). Once LVP has been disabled, only the standard high-voltage programming is available and must be used to program the device.

Memory that is not code-protected can be erased using either a block erase, or erased row by row, then written at any specified VDD. If code-protected memory is to be erased, a block erase is required.



## 23.0 INSTRUCTION SET SUMMARY

PIC18(L)F1XK22 devices incorporate the standard set of 75 PIC18 core instructions, as well as an extended set of 8 new instructions, for the optimization of code that is recursive or that utilizes a software stack. The extended set is discussed later in this section.

### 23.1 Standard Instruction Set

The standard PIC18 instruction set adds many enhancements to the previous PIC<sup>®</sup> MCU instruction sets, while maintaining an easy migration from these PIC<sup>®</sup> MCU instruction sets. Most instructions are a single program memory word (16 bits), but there are four instructions that require two program memory locations.

Each single-word instruction is a 16-bit word divided into an opcode, which specifies the instruction type and one or more operands, which further specify the operation of the instruction.

The instruction set is highly orthogonal and is grouped into four basic categories:

- **Byte-oriented** operations
- **Bit-oriented** operations
- **Literal** operations
- **Control** operations

The PIC18 instruction set summary in [Table 23-2](#) lists **byte-oriented**, **bit-oriented**, **literal** and **control** operations. [Table 23-1](#) shows the opcode field descriptions.

Most **byte-oriented** instructions have three operands:

1. The file register (specified by 'f')
2. The destination of the result (specified by 'd')
3. The accessed memory (specified by 'a')

The file register designator 'f' specifies which file register is to be used by the instruction. The destination designator 'd' specifies where the result of the operation is to be placed. If 'd' is zero, the result is placed in the WREG register. If 'd' is one, the result is placed in the file register specified in the instruction.

All **bit-oriented** instructions have three operands:

1. The file register (specified by 'f')
2. The bit in the file register (specified by 'b')
3. The accessed memory (specified by 'a')

The bit field designator 'b' selects the number of the bit affected by the operation, while the file register designator 'f' represents the number of the file in which the bit is located.

The **literal** instructions may use some of the following operands:

- A literal value to be loaded into a file register (specified by 'k')
- The desired FSR register to load the literal value into (specified by 'f')
- No operand required (specified by '—')

The **control** instructions may use some of the following operands:

- A program memory address (specified by 'n')
- The mode of the `CALL` or `RETURN` instructions (specified by 's')
- The mode of the table read and table write instructions (specified by 'm')
- No operand required (specified by '—')

All instructions are a single word, except for four double-word instructions. These instructions were made double-word to contain the required information in 32 bits. In the second word, the 4 MSBs are '1's. If this second word is executed as an instruction (by itself), it will execute as a `NOOP`.

All single-word instructions are executed in a single instruction cycle, unless a conditional test is true or the program counter is changed as a result of the instruction. In these cases, the execution takes two instruction cycles, with the additional instruction cycle(s) executed as a `NOOP`.

The double-word instructions execute in two instruction cycles.

One instruction cycle consists of four oscillator periods. Thus, for an oscillator frequency of 4 MHz, the normal instruction execution time is 1 $\mu$ s. If a conditional test is true, or the program counter is changed as a result of an instruction, the instruction execution time is 2 $\mu$ s. Two-word branch instructions (if true) would take 3 $\mu$ s.

[Figure 23-1](#) shows the general formats that the instructions can have. All examples use the convention 'nnh' to represent a hexadecimal number.

The Instruction Set Summary, shown in [Table 23-2](#), lists the standard instructions recognized by the Microchip Assembler (MPASM<sup>™</sup>).

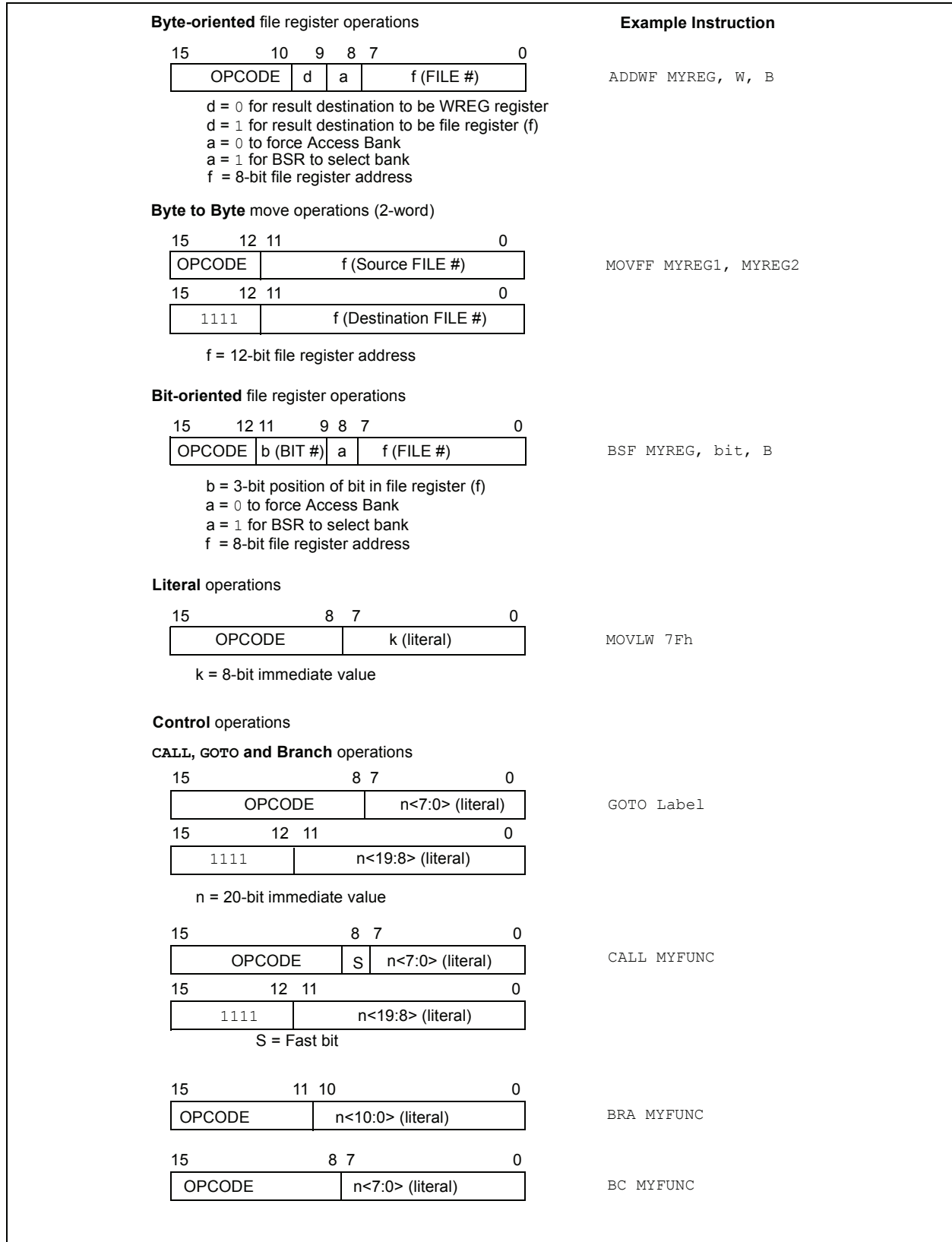
[Section 23.1.1 "Standard Instruction Set"](#) provides a description of each instruction.

# PIC18(L)F1XK22

**TABLE 23-1: OPCODE FIELD DESCRIPTIONS**

Field	Description
a	RAM access bit a = 0: RAM location in Access RAM (BSR register is ignored) a = 1: RAM bank is specified by BSR register
bbb	Bit address within an 8-bit file register (0 to 7).
BSR	Bank Select Register. Used to select the current RAM bank.
C, DC, Z, OV, N	ALU Status bits: <b>C</b> arry, <b>D</b> igit <b>C</b> arry, <b>Z</b> ero, <b>O</b> verflow, <b>N</b> egative.
d	Destination select bit d = 0: store result in WREG d = 1: store result in file register f
dest	Destination: either the WREG register or the specified register file location.
f	8-bit Register file address (00h to FFh) or 2-bit FSR designator (0h to 3h).
f <sub>s</sub>	12-bit Register file address (000h to FFFh). This is the source address.
f <sub>d</sub>	12-bit Register file address (000h to FFFh). This is the destination address.
GIE	Global Interrupt Enable bit.
k	Literal field, constant data or label (may be either an 8-bit, 12-bit or a 20-bit value).
label	Label name.
mm	The mode of the TBLPTR register for the table read and table write instructions. Only used with table read and table write instructions:
*	No change to register (such as TBLPTR with table reads and writes)
*+	Post-Increment register (such as TBLPTR with table reads and writes)
*-	Post-Decrement register (such as TBLPTR with table reads and writes)
+*	Pre-Increment register (such as TBLPTR with table reads and writes)
n	The relative address (2's complement number) for relative branch instructions or the direct address for CALL/BRANCH and RETURN instructions.
PC	Program Counter.
PCL	Program Counter Low Byte.
PCH	Program Counter High Byte.
PCLATH	Program Counter High Byte Latch.
PCLATU	Program Counter Upper Byte Latch.
$\overline{PD}$	Power-down bit.
PRODH	Product of Multiply High Byte.
PRODL	Product of Multiply Low Byte.
s	Fast Call/Return mode select bit s = 0: do not update into/from shadow registers s = 1: certain registers loaded into/from shadow registers (Fast mode)
TBLPTR	21-bit Table Pointer (points to a Program Memory location).
TABLAT	8-bit Table Latch.
T $\overline{O}$	Time-out bit.
TOS	Top-of-Stack.
u	Unused or unchanged.
WDT	Watchdog Timer.
WREG	Working register (accumulator).
x	Don't care ('0' or '1'). The assembler will generate code with x = 0. It is the recommended form of use for compatibility with all Microchip software tools.
z <sub>s</sub>	7-bit offset value for indirect addressing of register files (source).
z <sub>d</sub>	7-bit offset value for indirect addressing of register files (destination).
{ }	Optional argument.
[text]	Indicates an indexed address.
(text)	The contents of text.
[expr]<n>	Specifies bit n of the register indicated by the pointer expr.
→	Assigned to.
< >	Register bit field.
∈	In the set of.
<i>italics</i>	User defined term (font is Courier).

**FIGURE 23-1: GENERAL FORMAT FOR INSTRUCTIONS**



# PIC18(L)F1XK22

**TABLE 23-2: PIC18FXXXX INSTRUCTION SET**

Mnemonic, Operands	Description	Cycles	16-Bit Instruction Word		Status Affected	Notes			
			MSb	LSb					
<b>BYTE-ORIENTED OPERATIONS</b>									
ADDWF	f, d, a	Add WREG and f	1	0010	01da	ffff	ffff	C, DC, Z, OV, N	1, 2
ADDWFC	f, d, a	Add WREG and CARRY bit to f	1	0010	00da	ffff	ffff	C, DC, Z, OV, N	1, 2
ANDWF	f, d, a	AND WREG with f	1	0001	01da	ffff	ffff	Z, N	1, 2
CLRF	f, a	Clear f	1	0110	101a	ffff	ffff	Z	2
COMF	f, d, a	Complement f	1	0001	11da	ffff	ffff	Z, N	1, 2
CPFSEQ	f, a	Compare f with WREG, skip =	1 (2 or 3)	0110	001a	ffff	ffff	None	4
CPFSGT	f, a	Compare f with WREG, skip >	1 (2 or 3)	0110	010a	ffff	ffff	None	4
CPFSLT	f, a	Compare f with WREG, skip <	1 (2 or 3)	0110	000a	ffff	ffff	None	1, 2
DECf	f, d, a	Decrement f	1	0000	01da	ffff	ffff	C, DC, Z, OV, N	1, 2, 3, 4
DECFSZ	f, d, a	Decrement f, Skip if 0	1 (2 or 3)	0010	11da	ffff	ffff	None	1, 2, 3, 4
DCFSNZ	f, d, a	Decrement f, Skip if Not 0	1 (2 or 3)	0100	11da	ffff	ffff	None	1, 2
INCF	f, d, a	Increment f	1	0010	10da	ffff	ffff	C, DC, Z, OV, N	1, 2, 3, 4
INCFSZ	f, d, a	Increment f, Skip if 0	1 (2 or 3)	0011	11da	ffff	ffff	None	4
INFSNZ	f, d, a	Increment f, Skip if Not 0	1 (2 or 3)	0100	10da	ffff	ffff	None	1, 2
IORWF	f, d, a	Inclusive OR WREG with f	1	0001	00da	ffff	ffff	Z, N	1, 2
MOVf	f, d, a	Move f	1	0101	00da	ffff	ffff	Z, N	1
MOVFF	f <sub>s</sub> , f <sub>d</sub>	Move f <sub>s</sub> (source) to f <sub>d</sub> (destination)	2	1100	ffff	ffff	ffff	None	
MOVWF	f, a	Move WREG to f	1	0110	111a	ffff	ffff	None	
MULWF	f, a	Multiply WREG with f	1	0000	001a	ffff	ffff	None	1, 2
NEGF	f, a	Negate f	1	0110	110a	ffff	ffff	C, DC, Z, OV, N	
RLCF	f, d, a	Rotate Left f through Carry	1	0011	01da	ffff	ffff	C, Z, N	1, 2
RLNCF	f, d, a	Rotate Left f (No Carry)	1	0100	01da	ffff	ffff	Z, N	
RRCF	f, d, a	Rotate Right f through Carry	1	0011	00da	ffff	ffff	C, Z, N	
RRNCF	f, d, a	Rotate Right f (No Carry)	1	0100	00da	ffff	ffff	Z, N	
SETf	f, a	Set f	1	0110	100a	ffff	ffff	None	1, 2
SUBFWB	f, d, a	Subtract f from WREG with borrow	1	0101	01da	ffff	ffff	C, DC, Z, OV, N	
SUBWF	f, d, a	Subtract WREG from f	1	0101	11da	ffff	ffff	C, DC, Z, OV, N	1, 2
SUBWFB	f, d, a	Subtract WREG from f with borrow	1	0101	10da	ffff	ffff	C, DC, Z, OV, N	
SWAPF	f, d, a	Swap nibbles in f	1	0011	10da	ffff	ffff	None	4
TSTFSZ	f, a	Test f, skip if 0	1 (2 or 3)	0110	011a	ffff	ffff	None	1, 2
XORWF	f, d, a	Exclusive OR WREG with f	1	0001	10da	ffff	ffff	Z, N	

- Note 1:** When a PORT register is modified as a function of itself (e.g., MOVF PORTE, 1, 0), the value used will be that value present on the pins themselves. For example, if the data latch is '1' for a pin configured as input and is driven low by an external device, the data will be written back with a '0'.
- 2:** If this instruction is executed on the TMR0 register (and where applicable, 'd' = 1), the prescaler will be cleared if assigned.
- 3:** If Program Counter (PC) is modified or a conditional test is true, the instruction requires two cycles. The second cycle is executed as a NOP.
- 4:** Some instructions are two-word instructions. The second word of these instructions will be executed as a NOP unless the first word of the instruction retrieves the information embedded in these 16 bits. This ensures that all program memory locations have a valid instruction.

**TABLE 23-2: PIC18FXXXX INSTRUCTION SET (CONTINUED)**

Mnemonic, Operands	Description	Cycles	16-Bit Instruction Word				Status Affected	Notes	
			MSb			LSb			
<b>BIT-ORIENTED OPERATIONS</b>									
BCF	f, b, a	Bit Clear f	1	1001	bbba	ffff	ffff	None	1, 2
BSF	f, b, a	Bit Set f	1	1000	bbba	ffff	ffff	None	1, 2
BTFS	f, b, a	Bit Test f, Skip if Clear	1 (2 or 3)	1011	bbba	ffff	ffff	None	3, 4
BTFS	f, b, a	Bit Test f, Skip if Set	1 (2 or 3)	1010	bbba	ffff	ffff	None	3, 4
BTG	f, b, a	Bit Toggle f	1	0111	bbba	ffff	ffff	None	1, 2
<b>CONTROL OPERATIONS</b>									
BC	n	Branch if Carry	1 (2)	1110	0010	nnnn	nnnn	None	4
BN	n	Branch if Negative	1 (2)	1110	0110	nnnn	nnnn	None	
BNC	n	Branch if Not Carry	1 (2)	1110	0011	nnnn	nnnn	None	
BNN	n	Branch if Not Negative	1 (2)	1110	0111	nnnn	nnnn	None	
BNOV	n	Branch if Not Overflow	1 (2)	1110	0101	nnnn	nnnn	None	
BNZ	n	Branch if Not Zero	1 (2)	1110	0001	nnnn	nnnn	None	
BOV	n	Branch if Overflow	1 (2)	1110	0100	nnnn	nnnn	None	
BRA	n	Branch Unconditionally	2	1101	0nnn	nnnn	nnnn	None	
BZ	n	Branch if Zero	1 (2)	1110	0000	nnnn	nnnn	None	
CALL	k, s	Call subroutine	2	1110	110s	kkkk	kkkk	None	
		1st word							
		2nd word		1111	kkkk	kkkk	kkkk		
CLRWDT	—	Clear Watchdog Timer	1	0000	0000	0000	0100	$\overline{TO}$ , $\overline{PD}$	
DAW	—	Decimal Adjust WREG	1	0000	0000	0000	0111	C	
GOTO	k	Go to address	2	1110	1111	kkkk	kkkk	None	
		1st word							
		2nd word		1111	kkkk	kkkk	kkkk		
NOP	—	No Operation	1	0000	0000	0000	0000	None	
NOP	—	No Operation	1	1111	xxxx	xxxx	xxxx	None	
POP	—	Pop top of return stack (TOS)	1	0000	0000	0000	0110	None	
PUSH	—	Push top of return stack (TOS)	1	0000	0000	0000	0101	None	
RCALL	n	Relative Call	2	1101	1nnn	nnnn	nnnn	None	
RESET		Software device Reset	1	0000	0000	1111	1111	All	
RETFIE	s	Return from interrupt enable	2	0000	0000	0001	000s	GIE/GIEH, PEIE/GIEL	
RETLW	k	Return with literal in WREG	2	0000	1100	kkkk	kkkk	None	
RETURN	s	Return from Subroutine	2	0000	0000	0001	001s	None	
SLEEP	—	Go into Standby mode	1	0000	0000	0000	0011	$\overline{TO}$ , $\overline{PD}$	

- Note 1:** When a PORT register is modified as a function of itself (e.g., `MOVF PORTB, 1, 0`), the value used will be that value present on the pins themselves. For example, if the data latch is '1' for a pin configured as input and is driven low by an external device, the data will be written back with a '0'.
- 2:** If this instruction is executed on the TMR0 register (and where applicable, 'd' = 1), the prescaler will be cleared if assigned.
- 3:** If Program Counter (PC) is modified or a conditional test is true, the instruction requires two cycles. The second cycle is executed as a `NOP`.
- 4:** Some instructions are two-word instructions. The second word of these instructions will be executed as a `NOP` unless the first word of the instruction retrieves the information embedded in these 16 bits. This ensures that all program memory locations have a valid instruction.

# PIC18(L)F1XK22

**TABLE 23-2: PIC18FXXXX INSTRUCTION SET (CONTINUED)**

Mnemonic, Operands	Description	Cycles	16-Bit Instruction Word				Status Affected	Notes	
			MSb			LSb			
<b>LITERAL OPERATIONS</b>									
ADDLW	k	Add literal and WREG	1	0000	1111	kkkk	kkkk	C, DC, Z, OV, N	
ANDLW	k	AND literal with WREG	1	0000	1011	kkkk	kkkk	Z, N	
IORLW	k	Inclusive OR literal with WREG	1	0000	1001	kkkk	kkkk	Z, N	
LFSR	f, k	Move literal (12-bit) 2nd word to FSR(f) 1st word	2	1110	1110	00ff	kkkk	None	
MOVLB	k	Move literal to BSR<3:0>	1	0000	0001	0000	kkkk	None	
MOVLW	k	Move literal to WREG	1	0000	1110	kkkk	kkkk	None	
MULLW	k	Multiply literal with WREG	1	0000	1101	kkkk	kkkk	None	
RETLW	k	Return with literal in WREG	2	0000	1100	kkkk	kkkk	None	
SUBLW	k	Subtract WREG from literal	1	0000	1000	kkkk	kkkk	C, DC, Z, OV, N	
XORLW	k	Exclusive OR literal with WREG	1	0000	1010	kkkk	kkkk	Z, N	
<b>DATA MEMORY ↔ PROGRAM MEMORY OPERATIONS</b>									
TBLRD*		Table Read	2	0000	0000	0000	1000	None	
TBLRD*+		Table Read with post-increment		0000	0000	0000	1001	None	
TBLRD*-		Table Read with post-decrement		0000	0000	0000	1010	None	
TBLRD*+		Table Read with pre-increment		0000	0000	0000	1011	None	
TBLWT*		Table Write	2	0000	0000	0000	1100	None	
TBLWT*+		Table Write with post-increment		0000	0000	0000	1101	None	
TBLWT*-		Table Write with post-decrement		0000	0000	0000	1110	None	
TBLWT*+		Table Write with pre-increment		0000	0000	0000	1111	None	

- Note 1:** When a PORT register is modified as a function of itself (e.g., `MOVF PORTB, 1, 0`), the value used will be that value present on the pins themselves. For example, if the data latch is '1' for a pin configured as input and is driven low by an external device, the data will be written back with a '0'.
- 2:** If this instruction is executed on the TMR0 register (and where applicable, 'd' = 1), the prescaler will be cleared if assigned.
- 3:** If Program Counter (PC) is modified or a conditional test is true, the instruction requires two cycles. The second cycle is executed as a `NOP`.
- 4:** Some instructions are two-word instructions. The second word of these instructions will be executed as a `NOP` unless the first word of the instruction retrieves the information embedded in these 16 bits. This ensures that all program memory locations have a valid instruction.

## 23.1.1 STANDARD INSTRUCTION SET

### ADDLW ADD literal to W

Syntax:	ADDLW k								
Operands:	$0 \leq k \leq 255$								
Operation:	$(W) + k \rightarrow W$								
Status Affected:	N, OV, C, DC, Z								
Encoding:	<table border="1" style="display: inline-table;"><tr><td>0000</td><td>1111</td><td>kkkk</td><td>kkkk</td></tr></table>	0000	1111	kkkk	kkkk				
0000	1111	kkkk	kkkk						
Description:	The contents of W are added to the 8-bit literal 'k' and the result is placed in W.								
Words:	1								
Cycles:	1								
Q Cycle Activity:	<table border="1" style="display: inline-table;"><tr><td>Q1</td><td>Q2</td><td>Q3</td><td>Q4</td></tr><tr><td>Decode</td><td>Read literal 'k'</td><td>Process Data</td><td>Write to W</td></tr></table>	Q1	Q2	Q3	Q4	Decode	Read literal 'k'	Process Data	Write to W
Q1	Q2	Q3	Q4						
Decode	Read literal 'k'	Process Data	Write to W						

**Example:**           ADDLW 15h

Before Instruction  
W = 10h  
After Instruction  
W = 25h

### ADDWF ADD W to f

Syntax:	ADDWF f {,d {,a}}								
Operands:	$0 \leq f \leq 255$ $d \in [0,1]$ $a \in [0,1]$								
Operation:	$(W) + (f) \rightarrow \text{dest}$								
Status Affected:	N, OV, C, DC, Z								
Encoding:	<table border="1" style="display: inline-table;"><tr><td>0010</td><td>01da</td><td>ffff</td><td>ffff</td></tr></table>	0010	01da	ffff	ffff				
0010	01da	ffff	ffff						
Description:	Add W to register 'f'. If 'd' is '0', the result is stored in W. If 'd' is '1', the result is stored back in register 'f' (default). If 'a' is '0', the Access Bank is selected. If 'a' is '1', the BSR is used to select the GPR bank (default). If 'a' is '0' and the extended instruction set is enabled, this instruction operates in Indexed Literal Offset Addressing mode whenever $f \leq 95$ (5Fh). See <a href="#">Section 23.2.3 "Byte-Oriented and Bit-Oriented Instructions in Indexed Literal Offset Mode"</a> for details.								
Words:	1								
Cycles:	1								
Q Cycle Activity:	<table border="1" style="display: inline-table;"><tr><td>Q1</td><td>Q2</td><td>Q3</td><td>Q4</td></tr><tr><td>Decode</td><td>Read register 'f'</td><td>Process Data</td><td>Write to destination</td></tr></table>	Q1	Q2	Q3	Q4	Decode	Read register 'f'	Process Data	Write to destination
Q1	Q2	Q3	Q4						
Decode	Read register 'f'	Process Data	Write to destination						

**Example:**           ADDWF REG, 0, 0

Before Instruction  
W = 17h  
REG = 0C2h  
After Instruction  
W = 0D9h  
REG = 0C2h

**Note:** All PIC18 instructions may take an optional label argument preceding the instruction mnemonic for use in symbolic addressing. If a label is used, the instruction format then becomes: {label} instruction argument(s).

# PIC18(L)F1XK22

**ADDWFC**      **ADD W and CARRY bit to f**

Syntax:            ADDWFC    f {,d {,a}}

Operands:         $0 \leq f \leq 255$   
 $d \in [0,1]$   
 $a \in [0,1]$

Operation:        (W) + (f) + (C) → dest

Status Affected: N,OV, C, DC, Z

Encoding:        

0010	00da	ffff	ffff
------	------	------	------

Description:     Add W, the CARRY flag and data memory location 'f'. If 'd' is '0', the result is placed in W. If 'd' is '1', the result is placed in data memory location 'f'.  
 If 'a' is '0', the Access Bank is selected. If 'a' is '1', the BSR is used to select the GPR bank (default).  
 If 'a' is '0' and the extended instruction set is enabled, this instruction operates in Indexed Literal Offset Addressing mode whenever  $f \leq 95$  (5Fh). See [Section 23.2.3 "Byte-Oriented and Bit-Oriented Instructions in Indexed Literal Offset Mode"](#) for details.

Words:            1

Cycles:            1

Q Cycle Activity:

Q1	Q2	Q3	Q4
Decode	Read register 'f'	Process Data	Write to destination

Example:            ADDWFC    REG, 0, 1

Before Instruction  
 CARRY bit = 1  
 REG        = 02h  
 W          = 4Dh

After Instruction  
 CARRY bit = 0  
 REG        = 02h  
 W          = 50h

**ANDLW**            **AND literal with W**

Syntax:            ANDLW    k

Operands:         $0 \leq k \leq 255$

Operation:        (W) .AND. k → W

Status Affected: N, Z

Encoding:        

0000	1011	kkkk	kkkk
------	------	------	------

Description:     The contents of W are AND'ed with the 8-bit literal 'k'. The result is placed in W.

Words:            1

Cycles:            1

Q Cycle Activity:

Q1	Q2	Q3	Q4
Decode	Read literal 'k'	Process Data	Write to W

Example:            ANDLW    05Fh

Before Instruction  
 W        =    A3h

After Instruction  
 W        =    03h



**ANDWF**      **AND W with f**

---

Syntax:            ANDWF    f {,d {,a}}

Operands:         $0 \leq f \leq 255$   
 $d \in [0,1]$   
 $a \in [0,1]$

Operation:        (W) .AND. (f) → dest

Status Affected:    N, Z

Encoding:        

0001	01da	ffff	ffff
------	------	------	------

Description:      The contents of W are AND'ed with register 'f'. If 'd' is '0', the result is stored in W. If 'd' is '1', the result is stored back in register 'f' (default).  
 If 'a' is '0', the Access Bank is selected. If 'a' is '1', the BSR is used to select the GPR bank (default).  
 If 'a' is '0' and the extended instruction set is enabled, this instruction operates in Indexed Literal Offset Addressing mode whenever  $f \leq 95$  (5Fh). See [Section 23.2.3 "Byte-Oriented and Bit-Oriented Instructions in Indexed Literal Offset Mode"](#) for details.

Words:            1

Cycles:            1

Q Cycle Activity:

Q1	Q2	Q3	Q4
Decode	Read register 'f'	Process Data	Write to destination

**Example:**            ANDWF    REG, 0, 0

Before Instruction

W        =    17h  
 REG     =    C2h

After Instruction

W        =    02h  
 REG     =    C2h

**BC**                **Branch if Carry**

---

Syntax:            BC    n

Operands:         $-128 \leq n \leq 127$

Operation:        if CARRY bit is '1'  
 (PC) + 2 + 2n → PC

Status Affected:    None

Encoding:        

1110	0010	nnnn	nnnn
------	------	------	------

Description:      If the CARRY bit is '1', then the program will branch.  
 The 2's complement number '2n' is added to the PC. Since the PC will have incremented to fetch the next instruction, the new address will be PC + 2 + 2n. This instruction is then a two-cycle instruction.

Words:            1

Cycles:            1(2)

Q Cycle Activity:  
 If Jump:

Q1	Q2	Q3	Q4
Decode	Read literal 'n'	Process Data	Write to PC
No operation	No operation	No operation	No operation

If No Jump:

Q1	Q2	Q3	Q4
Decode	Read literal 'n'	Process Data	No operation

**Example:**            HERE        BC    5

Before Instruction

PC        =    address (HERE)

After Instruction

If CARRY = 1;  
 PC        =    address (HERE + 12)  
 If CARRY = 0;  
 PC        =    address (HERE + 2)

# PIC18(L)F1XK22

**BCF**                      **Bit Clear f**

---

Syntax:                    BCF   f, b {,a}

Operands:                 $0 \leq f \leq 255$   
 $0 \leq b \leq 7$   
 $a \in \{0,1\}$

Operation:                 $0 \rightarrow f < b >$

Status Affected:        None

Encoding:                

1001	bbba	ffff	ffff
------	------	------	------

Description:             Bit 'b' in register 'f' is cleared.  
 If 'a' is '0', the Access Bank is selected.  
 If 'a' is '1', the BSR is used to select the GPR bank (default).  
 If 'a' is '0' and the extended instruction set is enabled, this instruction operates in Indexed Literal Offset Addressing mode whenever  $f \leq 95$  (5Fh). See [Section 23.2.3 "Byte-Oriented and Bit-Oriented Instructions in Indexed Literal Offset Mode"](#) for details.

Words:                    1

Cycles:                    1

Q Cycle Activity:

Q1	Q2	Q3	Q4
Decode	Read register 'f'	Process Data	Write register 'f'

**Example:**                BCF        FLAG\_REG, 7, 0

Before Instruction  
             FLAG\_REG =     C7h

After Instruction  
             FLAG\_REG =     47h

**BN**                        **Branch if Negative**

---

Syntax:                    BN   n

Operands:                 $-128 \leq n \leq 127$

Operation:                if NEGATIVE bit is '1'  
 $(PC) + 2 + 2n \rightarrow PC$

Status Affected:        None

Encoding:                

1110	0110	nnnn	nnnn
------	------	------	------

Description:             If the NEGATIVE bit is '1', then the program will branch.  
 The 2's complement number '2n' is added to the PC. Since the PC will have incremented to fetch the next instruction, the new address will be  $PC + 2 + 2n$ . This instruction is then a two-cycle instruction.

Words:                    1

Cycles:                    1(2)

Q Cycle Activity:

If Jump:

Q1	Q2	Q3	Q4
Decode	Read literal 'n'	Process Data	Write to PC
No operation	No operation	No operation	No operation

If No Jump:

Q1	Q2	Q3	Q4
Decode	Read literal 'n'	Process Data	No operation

**Example:**                       HERE        BN    Jump

Before Instruction  
             PC            =    address (HERE)

After Instruction  
             If NEGATIVE = 1;  
                           PC            =    address (Jump)  
             If NEGATIVE = 0;  
                           PC            =    address (HERE + 2)

# PIC18(L)F1XK22

**BNC**                      **Branch if Not Carry**

---

Syntax:                    BNC n

Operands:                 $-128 \leq n \leq 127$

Operation:                if CARRY bit is '0'  
(PC) + 2 + 2n → PC

Status Affected:        None

Encoding:                

1110	0011	nnnn	nnnn
------	------	------	------

Description:             If the CARRY bit is '0', then the program will branch. The 2's complement number '2n' is added to the PC. Since the PC will have incremented to fetch the next instruction, the new address will be PC + 2 + 2n. This instruction is then a two-cycle instruction.

Words:                    1

Cycles:                   1(2)

Q Cycle Activity:  
If Jump:

Q1	Q2	Q3	Q4
Decode	Read literal 'n'	Process Data	Write to PC
No operation	No operation	No operation	No operation

If No Jump:

Q1	Q2	Q3	Q4
Decode	Read literal 'n'	Process Data	No operation

**Example:**                HERE            BNC    Jump

Before Instruction  
PC = address (HERE)

After Instruction  
If CARRY = 0;  
PC = address (Jump)  
If CARRY = 1;  
PC = address (HERE + 2)

**BNN**                      **Branch if Not Negative**

---

Syntax:                    BNN n

Operands:                 $-128 \leq n \leq 127$

Operation:                if NEGATIVE bit is '0'  
(PC) + 2 + 2n → PC

Status Affected:        None

Encoding:                

1110	0111	nnnn	nnnn
------	------	------	------

Description:             If the NEGATIVE bit is '0', then the program will branch. The 2's complement number '2n' is added to the PC. Since the PC will have incremented to fetch the next instruction, the new address will be PC + 2 + 2n. This instruction is then a two-cycle instruction.

Words:                    1

Cycles:                   1(2)

Q Cycle Activity:  
If Jump:

Q1	Q2	Q3	Q4
Decode	Read literal 'n'	Process Data	Write to PC
No operation	No operation	No operation	No operation

If No Jump:

Q1	Q2	Q3	Q4
Decode	Read literal 'n'	Process Data	No operation

**Example:**                HERE            BNN    Jump

Before Instruction  
PC = address (HERE)

After Instruction  
If NEGATIVE = 0;  
PC = address (Jump)  
If NEGATIVE = 1;  
PC = address (HERE + 2)

# PIC18(L)F1XK22

## BNOV Branch if Not Overflow

Syntax: BNOV n

Operands:  $-128 \leq n \leq 127$

Operation: if OVERFLOW bit is '0'  
(PC) + 2 + 2n → PC

Status Affected: None

Encoding: 

1110	0101	nnnn	nnnn
------	------	------	------

Description: If the OVERFLOW bit is '0', then the program will branch. The 2's complement number '2n' is added to the PC. Since the PC will have incremented to fetch the next instruction, the new address will be PC + 2 + 2n. This instruction is then a two-cycle instruction.

Words: 1

Cycles: 1(2)

Q Cycle Activity:  
If Jump:

Q1	Q2	Q3	Q4
Decode	Read literal 'n'	Process Data	Write to PC
No operation	No operation	No operation	No operation

If No Jump:

Q1	Q2	Q3	Q4
Decode	Read literal 'n'	Process Data	No operation

**Example:**            HERE            BNOV Jump

Before Instruction  
PC = address (HERE)

After Instruction  
If OVERFLOW = 0;  
PC = address (Jump)  
If OVERFLOW = 1;  
PC = address (HERE + 2)

## BNZ Branch if Not Zero

Syntax: BNZ n

Operands:  $-128 \leq n \leq 127$

Operation: if ZERO bit is '0'  
(PC) + 2 + 2n → PC

Status Affected: None

Encoding: 

1110	0001	nnnn	nnnn
------	------	------	------

Description: If the ZERO bit is '0', then the program will branch. The 2's complement number '2n' is added to the PC. Since the PC will have incremented to fetch the next instruction, the new address will be PC + 2 + 2n. This instruction is then a two-cycle instruction.

Words: 1

Cycles: 1(2)

Q Cycle Activity:  
If Jump:

Q1	Q2	Q3	Q4
Decode	Read literal 'n'	Process Data	Write to PC
No operation	No operation	No operation	No operation

If No Jump:

Q1	Q2	Q3	Q4
Decode	Read literal 'n'	Process Data	No operation

**Example:**            HERE            BNZ Jump

Before Instruction  
PC = address (HERE)

After Instruction  
If ZERO = 0;  
PC = address (Jump)  
If ZERO = 1;  
PC = address (HERE + 2)

# PIC18(L)F1XK22

## BRA Unconditional Branch

Syntax: BRA n

Operands:  $-1024 \leq n \leq 1023$

Operation:  $(PC) + 2 + 2n \rightarrow PC$

Status Affected: None

Encoding: 

1101	0nnn	nnnn	nnnn
------	------	------	------

Description: Add the 2's complement number '2n' to the PC. Since the PC will have incremented to fetch the next instruction, the new address will be  $PC + 2 + 2n$ . This instruction is a two-cycle instruction.

Words: 1

Cycles: 2

Q Cycle Activity:

Q1	Q2	Q3	Q4
Decode	Read literal 'n'	Process Data	Write to PC
No operation	No operation	No operation	No operation

**Example:**            HERE       BRA   Jump

Before Instruction  
PC            =   address (HERE)

After Instruction  
PC            =   address (Jump)

## BSF Bit Set f

Syntax: BSF f, b {,a}

Operands:  $0 \leq f \leq 255$   
 $0 \leq b \leq 7$   
 $a \in [0,1]$

Operation:  $1 \rightarrow f<b>$

Status Affected: None

Encoding: 

1000	bbba	ffff	ffff
------	------	------	------

Description: Bit 'b' in register 'f' is set.  
If 'a' is '0', the Access Bank is selected.  
If 'a' is '1', the BSR is used to select the GPR bank (default).  
If 'a' is '0' and the extended instruction set is enabled, this instruction operates in Indexed Literal Offset Addressing mode whenever  $f \leq 95$  (5Fh). See [Section 23.2.3 "Byte-Oriented and Bit-Oriented Instructions in Indexed Literal Offset Mode"](#) for details.

Words: 1

Cycles: 1

Q Cycle Activity:

Q1	Q2	Q3	Q4
Decode	Read register 'f'	Process Data	Write register 'f'

**Example:**            BSF       FLAG\_REG, 7, 1

Before Instruction  
FLAG\_REG    =   0Ah

After Instruction  
FLAG\_REG    =   8Ah

# PIC18(L)F1XK22

**BTFSK**                    **Bit Test File, Skip if Clear**

Syntax:                    BTFSK f, b {,a}

Operands:                 $0 \leq f \leq 255$   
 $0 \leq b \leq 7$   
 $a \in [0,1]$

Operation:                skip if (f<b> = 0

Status Affected:        None

Encoding:                

1011	bbba	ffff	ffff
------	------	------	------

Description:             If bit 'b' in register 'f' is '0', then the next instruction is skipped. If bit 'b' is '0', then the next instruction fetched during the current instruction execution is discarded and a NOP is executed instead, making this a two-cycle instruction.  
 If 'a' is '0', the Access Bank is selected. If 'a' is '1', the BSR is used to select the GPR bank (default).  
 If 'a' is '0' and the extended instruction set is enabled, this instruction operates in Indexed Literal Offset Addressing mode whenever  $f \leq 95$  (5Fh).  
 See [Section 23.2.3 "Byte-Oriented and Bit-Oriented Instructions in Indexed Literal Offset Mode"](#) for details.

Words:                    1

Cycles:                    1(2)  
**Note:** 3 cycles if skip and followed by a 2-word instruction.

Q Cycle Activity:

Q1	Q2	Q3	Q4
Decode	Read register 'f'	Process Data	No operation

If skip:

Q1	Q2	Q3	Q4
No operation	No operation	No operation	No operation

If skip and followed by 2-word instruction:

Q1	Q2	Q3	Q4
No operation	No operation	No operation	No operation
No operation	No operation	No operation	No operation

**Example:**                HERE    BTFSK    FLAG, 1, 0  
 FALSE    :  
 TRUE     :

Before Instruction  
 PC = address (HERE)  
 After Instruction  
 If FLAG<1> = 0;  
   PC = address (TRUE)  
 If FLAG<1> = 1;  
   PC = address (FALSE)

**BTFS**                    **Bit Test File, Skip if Set**

Syntax:                    BTFS f, b {,a}

Operands:                 $0 \leq f \leq 255$   
 $0 \leq b < 7$   
 $a \in [0,1]$

Operation:                skip if (f<b> = 1

Status Affected:        None

Encoding:                

1010	bbba	ffff	ffff
------	------	------	------

Description:             If bit 'b' in register 'f' is '1', then the next instruction is skipped. If bit 'b' is '1', then the next instruction fetched during the current instruction execution is discarded and a NOP is executed instead, making this a two-cycle instruction.  
 If 'a' is '0', the Access Bank is selected. If 'a' is '1', the BSR is used to select the GPR bank (default).  
 If 'a' is '0' and the extended instruction set is enabled, this instruction operates in Indexed Literal Offset Addressing mode whenever  $f \leq 95$  (5Fh).  
 See [Section 23.2.3 "Byte-Oriented and Bit-Oriented Instructions in Indexed Literal Offset Mode"](#) for details.

Words:                    1

Cycles:                    1(2)  
**Note:** 3 cycles if skip and followed by a 2-word instruction.

Q Cycle Activity:

Q1	Q2	Q3	Q4
Decode	Read register 'f'	Process Data	No operation

If skip:

Q1	Q2	Q3	Q4
No operation	No operation	No operation	No operation

If skip and followed by 2-word instruction:

Q1	Q2	Q3	Q4
No operation	No operation	No operation	No operation
No operation	No operation	No operation	No operation

**Example:**                HERE    BTFS    FLAG, 1, 0  
 FALSE    :  
 TRUE     :

Before Instruction  
 PC = address (HERE)  
 After Instruction  
 If FLAG<1> = 0;  
   PC = address (FALSE)  
 If FLAG<1> = 1;  
   PC = address (TRUE)

**BTG**                      **Bit Toggle f**

---

Syntax:                    BTG f, b {,a}

Operands:                 $0 \leq f \leq 255$   
 $0 \leq b < 7$   
 $a \in [0,1]$

Operation:                 $(\overline{f\langle b \rangle}) \rightarrow f\langle b \rangle$

Status Affected:        None

Encoding:                

0111	bbba	ffff	ffff
------	------	------	------

Description:             Bit 'b' in data memory location 'f' is inverted.  
 If 'a' is '0', the Access Bank is selected.  
 If 'a' is '1', the BSR is used to select the GPR bank (default).  
 If 'a' is '0' and the extended instruction set is enabled, this instruction operates in Indexed Literal Offset Addressing mode whenever  $f \leq 95$  (5Fh). See [Section 23.2.3 "Byte-Oriented and Bit-Oriented Instructions in Indexed Literal Offset Mode"](#) for details.

Words:                    1

Cycles:                    1

Q Cycle Activity:

Q1	Q2	Q3	Q4
Decode	Read register 'f'	Process Data	Write register 'f'

**Example:**                BTG     PORTC, 4, 0

Before Instruction:  
           PORTC = 0111 0101 [75h]

After Instruction:  
           PORTC = 0110 0101 [65h]

**BOV**                      **Branch if Overflow**

---

Syntax:                    BOV n

Operands:                 $-128 \leq n \leq 127$

Operation:                if OVERFLOW bit is '1'  
 $(PC) + 2 + 2n \rightarrow PC$

Status Affected:        None

Encoding:                

1110	0100	nnnn	nnnn
------	------	------	------

Description:             If the OVERFLOW bit is '1', then the program will branch.  
 The 2's complement number '2n' is added to the PC. Since the PC will have incremented to fetch the next instruction, the new address will be  $PC + 2 + 2n$ . This instruction is then a two-cycle instruction.

Words:                    1

Cycles:                    1(2)

Q Cycle Activity:  
 If Jump:

Q1	Q2	Q3	Q4
Decode	Read literal 'n'	Process Data	Write to PC
No operation	No operation	No operation	No operation

If No Jump:

Q1	Q2	Q3	Q4
Decode	Read literal 'n'	Process Data	No operation

**Example:**                               HERE                BOV    Jump

Before Instruction  
           PC                =    address (HERE)

After Instruction  
           If OVERFLOW = 1;  
           PC                =    address (Jump)  
           If OVERFLOW = 0;  
           PC                =    address (HERE + 2)

# PIC18(L)F1XK22

## BZ Branch if Zero

**Syntax:** BZ n

**Operands:**  $-128 \leq n \leq 127$

**Operation:** if ZERO bit is '1'  
(PC) + 2 + 2n → PC

**Status Affected:** None

**Encoding:**

1110	0000	nnnn	nnnn
------	------	------	------

**Description:** If the ZERO bit is '1', then the program will branch. The 2's complement number '2n' is added to the PC. Since the PC will have incremented to fetch the next instruction, the new address will be PC + 2 + 2n. This instruction is then a two-cycle instruction.

**Words:** 1

**Cycles:** 1(2)

**Q Cycle Activity:**

**If Jump:**

Q1	Q2	Q3	Q4
Decode	Read literal 'n'	Process Data	Write to PC
No operation	No operation	No operation	No operation

**If No Jump:**

Q1	Q2	Q3	Q4
Decode	Read literal 'n'	Process Data	No operation

**Example:**            HERE            BZ    Jump

Before Instruction  
PC = address (HERE)

After Instruction  
If ZERO = 1;  
PC = address (Jump)  
If ZERO = 0;  
PC = address (HERE + 2)

## CALL Subroutine Call

**Syntax:** CALL k {,s}

**Operands:**  $0 \leq k \leq 1048575$   
 $s \in [0,1]$

**Operation:** (PC) + 4 → TOS,  
k → PC<20:1>,  
if s = 1  
(W) → WS,  
(Status) → STATUSS,  
(BSR) → BSRS

**Status Affected:** None

**Encoding:**

1110	110s	k <sub>7</sub> kkk	kkkk <sub>0</sub>
1111	k <sub>19</sub> kkk	kkkk	kkkk <sub>8</sub>

**Description:** Subroutine call of entire 2-Mbyte memory range. First, return address (PC + 4) is pushed onto the return stack. If 's' = 1, the W, Status and BSR registers are also pushed into their respective shadow registers, WS, STATUSS and BSRS. If 's' = 0, no update occurs (default). Then, the 20-bit value 'k' is loaded into PC<20:1>. CALL is a two-cycle instruction.

**Words:** 2

**Cycles:** 2

**Q Cycle Activity:**

Q1	Q2	Q3	Q4
Decode	Read literal 'k'<7:0>, PUSH PC to stack	PUSH PC to stack	Read literal 'k'<19:8>, Write to PC
No operation	No operation	No operation	No operation

**Example:**            HERE            CALL    THERE, 1

Before Instruction  
PC = address (HERE)

After Instruction  
PC = address (THERE)  
TOS = address (HERE + 4)  
WS = W  
BSRS = BSR  
STATUSS = Status



CLRf	Clear f								
Syntax:	CLRf f{,a}								
Operands:	0 ≤ f ≤ 255 a ∈ [0,1]								
Operation:	000h → f 1 → Z								
Status Affected:	Z								
Encoding:	<table border="1"> <tr> <td>0110</td> <td>101a</td> <td>ffff</td> <td>ffff</td> </tr> </table>	0110	101a	ffff	ffff				
0110	101a	ffff	ffff						
Description:	<p>Clears the contents of the specified register.</p> <p>If 'a' is '0', the Access Bank is selected.</p> <p>If 'a' is '1', the BSR is used to select the GPR bank (default).</p> <p>If 'a' is '0' and the extended instruction set is enabled, this instruction operates in Indexed Literal Offset Addressing mode whenever f ≤ 95 (5Fh). See <a href="#">Section 23.2.3 "Byte-Oriented and Bit-Oriented Instructions in Indexed Literal Offset Mode"</a> for details.</p>								
Words:	1								
Cycles:	1								
Q Cycle Activity:	<table border="1"> <thead> <tr> <th>Q1</th> <th>Q2</th> <th>Q3</th> <th>Q4</th> </tr> </thead> <tbody> <tr> <td>Decode</td> <td>Read register 'f'</td> <td>Process Data</td> <td>Write register 'f'</td> </tr> </tbody> </table>	Q1	Q2	Q3	Q4	Decode	Read register 'f'	Process Data	Write register 'f'
Q1	Q2	Q3	Q4						
Decode	Read register 'f'	Process Data	Write register 'f'						

**Example:** CLRf FLAG\_REG, 1

Before Instruction  
FLAG\_REG = 5Ah

After Instruction  
FLAG\_REG = 00h

CLRWDT	Clear Watchdog Timer								
Syntax:	CLRWDT								
Operands:	None								
Operation:	000h → WDT, 000h → WDT postscaler, 1 → $\overline{TO}$ , 1 → PD								
Status Affected:	$\overline{TO}$ , PD								
Encoding:	<table border="1"> <tr> <td>0000</td> <td>0000</td> <td>0000</td> <td>0100</td> </tr> </table>	0000	0000	0000	0100				
0000	0000	0000	0100						
Description:	CLRWDT instruction resets the Watchdog Timer. It also resets the postscaler of the WDT. Status bits, $\overline{TO}$ and PD, are set.								
Words:	1								
Cycles:	1								
Q Cycle Activity:	<table border="1"> <thead> <tr> <th>Q1</th> <th>Q2</th> <th>Q3</th> <th>Q4</th> </tr> </thead> <tbody> <tr> <td>Decode</td> <td>No operation</td> <td>Process Data</td> <td>No operation</td> </tr> </tbody> </table>	Q1	Q2	Q3	Q4	Decode	No operation	Process Data	No operation
Q1	Q2	Q3	Q4						
Decode	No operation	Process Data	No operation						

**Example:** CLRWDT

Before Instruction  
WDT Counter = ?

After Instruction  
WDT Counter = 00h  
WDT Postscaler = 0  
 $\overline{TO}$  = 1  
PD = 1

# PIC18(L)F1XK22

**COMF**                      **Complement f**

---

Syntax:                      COMF f {,d {,a}}

Operands:                     $0 \leq f \leq 255$   
 $d \in [0,1]$   
 $a \in [0,1]$

Operation:                     $(\bar{f}) \rightarrow \text{dest}$

Status Affected:            N, Z

Encoding:                    

0001	11da	ffff	ffff
------	------	------	------

Description:                The contents of register 'f' are complemented. If 'd' is '0', the result is stored in W. If 'd' is '1', the result is stored back in register 'f' (default). If 'a' is '0', the Access Bank is selected. If 'a' is '1', the BSR is used to select the GPR bank (default). If 'a' is '0' and the extended instruction set is enabled, this instruction operates in Indexed Literal Offset Addressing mode whenever  $f \leq 95$  (5Fh). See [Section 23.2.3 "Byte-Oriented and Bit-Oriented Instructions in Indexed Literal Offset Mode"](#) for details.

Words:                        1

Cycles:                        1

Q Cycle Activity:

Q1	Q2	Q3	Q4
Decode	Read register 'f'	Process Data	Write to destination

**Example:**                    COMF                      REG, 0, 0

Before Instruction  
REG = 13h

After Instruction  
REG = 13h  
W = ECh

**CPFSEQ**                    **Compare f with W, skip if f = W**

---

Syntax:                      CPFSEQ f {,a}

Operands:                     $0 \leq f \leq 255$   
 $a \in [0,1]$

Operation:                     $(f) - (W)$ ,  
skip if  $(f) = (W)$   
(unsigned comparison)

Status Affected:            None

Encoding:                    

0110	001a	ffff	ffff
------	------	------	------

Description:                Compares the contents of data memory location 'f' to the contents of W by performing an unsigned subtraction. If  $f = W$ , then the fetched instruction is discarded and a NOP is executed instead, making this a two-cycle instruction. If 'a' is '0', the Access Bank is selected. If 'a' is '1', the BSR is used to select the GPR bank (default). If 'a' is '0' and the extended instruction set is enabled, this instruction operates in Indexed Literal Offset Addressing mode whenever  $f \leq 95$  (5Fh). See [Section 23.2.3 "Byte-Oriented and Bit-Oriented Instructions in Indexed Literal Offset Mode"](#) for details.

Words:                        1

Cycles:                        1(2)

**Note:** 3 cycles if skip and followed by a 2-word instruction.

Q Cycle Activity:

Q1	Q2	Q3	Q4
Decode	Read register 'f'	Process Data	No operation

If skip:

Q1	Q2	Q3	Q4
No operation	No operation	No operation	No operation

If skip and followed by 2-word instruction:

Q1	Q2	Q3	Q4
No operation	No operation	No operation	No operation
No operation	No operation	No operation	No operation

**Example:**                    HERE                      CPFSEQ REG, 0  
NEQUAL                    :  
EQUAL                     :

Before Instruction  
PC Address = HERE  
W = ?  
REG = ?

After Instruction  
If REG = W;  
PC = Address (EQUAL)  
If REG  $\neq$  W;  
PC = Address (NEQUAL)

## CPFSGT Compare f with W, skip if f > W

Syntax: CPFSGT f{,a}  
 Operands:  $0 \leq f \leq 255$   
 $a \in [0,1]$   
 Operation:  $(f) - (W)$ ,  
 skip if  $(f) > (W)$   
 (unsigned comparison)  
 Status Affected: None

Encoding: 

0110	010a	ffff	ffff
------	------	------	------

Description: Compares the contents of data memory location 'f' to the contents of the W by performing an unsigned subtraction. If the contents of 'f' are greater than the contents of WREG, then the fetched instruction is discarded and a NOP is executed instead, making this a two-cycle instruction. If 'a' is '0', the Access Bank is selected. If 'a' is '1', the BSR is used to select the GPR bank (default). If 'a' is '0' and the extended instruction set is enabled, this instruction operates in Indexed Literal Offset Addressing mode whenever  $f \leq 95$  (5Fh). See [Section 23.2.3 "Byte-Oriented and Bit-Oriented Instructions in Indexed Literal Offset Mode"](#) for details.

Words: 1  
 Cycles: 1(2)  
**Note:** 3 cycles if skip and followed by a 2-word instruction.

Q Cycle Activity:

Q1	Q2	Q3	Q4
Decode	Read register 'f'	Process Data	No operation

If skip:

Q1	Q2	Q3	Q4
No operation	No operation	No operation	No operation

If skip and followed by 2-word instruction:

Q1	Q2	Q3	Q4
No operation	No operation	No operation	No operation
No operation	No operation	No operation	No operation

**Example:** HERE CPFSGT REG, 0  
 NGREATER :  
 GREATER :

Before Instruction  
 PC = Address (HERE)  
 W = ?  
 After Instruction  
 If REG > W;  
 PC = Address (GREATER)  
 If REG ≤ W;  
 PC = Address (NGREATER)

## CPFSLT Compare f with W, skip if f < W

Syntax: CPFSLT f{,a}  
 Operands:  $0 \leq f \leq 255$   
 $a \in [0,1]$   
 Operation:  $(f) - (W)$ ,  
 skip if  $(f) < (W)$   
 (unsigned comparison)  
 Status Affected: None

Encoding: 

0110	000a	ffff	ffff
------	------	------	------

Description: Compares the contents of data memory location 'f' to the contents of W by performing an unsigned subtraction. If the contents of 'f' are less than the contents of W, then the fetched instruction is discarded and a NOP is executed instead, making this a two-cycle instruction. If 'a' is '0', the Access Bank is selected. If 'a' is '1', the BSR is used to select the GPR bank (default).

Words: 1  
 Cycles: 1(2)  
**Note:** 3 cycles if skip and followed by a 2-word instruction.

Q Cycle Activity:

Q1	Q2	Q3	Q4
Decode	Read register 'f'	Process Data	No operation

If skip:

Q1	Q2	Q3	Q4
No operation	No operation	No operation	No operation

If skip and followed by 2-word instruction:

Q1	Q2	Q3	Q4
No operation	No operation	No operation	No operation
No operation	No operation	No operation	No operation

**Example:** HERE CPFSLT REG, 1  
 NLESS :  
 LESS :

Before Instruction  
 PC = Address (HERE)  
 W = ?  
 After Instruction  
 If REG < W;  
 PC = Address (LESS)  
 If REG ≥ W;  
 PC = Address (NLESS)

# PIC18(L)F1XK22

## DAW Decimal Adjust W Register

Syntax: DAW

Operands: None

Operation: If  $[W<3:0> > 9]$  or  $[DC = 1]$  then  $(W<3:0>) + 6 \rightarrow W<3:0>;$   
 else  $(W<3:0>) \rightarrow W<3:0>;$

If  $[W<7:4> + DC > 9]$  or  $[C = 1]$  then  $(W<7:4>) + 6 + DC \rightarrow W<7:4>;$   
 else  $(W<7:4>) + DC \rightarrow W<7:4>;$

Status Affected: C

Encoding: 

0000	0000	0000	0111
------	------	------	------

Description: DAW adjusts the eight-bit value in W, resulting from the earlier addition of two variables (each in packed BCD format) and produces a correct packed BCD result.

Words: 1

Cycles: 1

Q Cycle Activity:

Q1	Q2	Q3	Q4
Decode	Read register W	Process Data	Write W

### Example 1:

DAW

Before Instruction

W	=	A5h
C	=	0
DC	=	0

After Instruction

W	=	05h
C	=	1
DC	=	0

### Example 2:

Before Instruction

W	=	CEh
C	=	0
DC	=	0

After Instruction

W	=	34h
C	=	1
DC	=	0

## DECF Decrement f

Syntax: DECF  $f\{,d\}\{,a\}$

Operands:  $0 \leq f \leq 255$   
 $d \in [0,1]$   
 $a \in [0,1]$

Operation:  $(f) - 1 \rightarrow \text{dest}$

Status Affected: C, DC, N, OV, Z

Encoding: 

0000	01da	ffff	ffff
------	------	------	------

Description: Decrement register 'f'. If 'd' is '0', the result is stored in W. If 'd' is '1', the result is stored back in register 'f' (default).  
 If 'a' is '0', the Access Bank is selected. If 'a' is '1', the BSR is used to select the GPR bank (default).  
 If 'a' is '0' and the extended instruction set is enabled, this instruction operates in Indexed Literal Offset Addressing mode whenever  $f \leq 95$  (5Fh). See [Section 23.2.3 "Byte-Oriented and Bit-Oriented Instructions in Indexed Literal Offset Mode"](#) for details.

Words: 1

Cycles: 1

Q Cycle Activity:

Q1	Q2	Q3	Q4
Decode	Read register 'f'	Process Data	Write to destination

### Example:

DECF CNT, 1, 0

Before Instruction

CNT	=	01h
Z	=	0

After Instruction

CNT	=	00h
Z	=	1

**DECFSZ**      **Decrement f, skip if 0**

Syntax:      DECFSZ f {,d {,a}}

Operands:     $0 \leq f \leq 255$   
 $d \in [0,1]$   
 $a \in [0,1]$

Operation:    (f) – 1 → dest,  
 skip if result = 0

Status Affected:    None

Encoding:    

0010	11da	ffff	ffff
------	------	------	------

Description:    The contents of register 'f' are decremented. If 'd' is '0', the result is placed in W. If 'd' is '1', the result is placed back in register 'f' (default). If the result is '0', the next instruction, which is already fetched, is discarded and a NOP is executed instead, making it a two-cycle instruction. If 'a' is '0', the Access Bank is selected. If 'a' is '1', the BSR is used to select the GPR bank (default). If 'a' is '0' and the extended instruction set is enabled, this instruction operates in Indexed Literal Offset Addressing mode whenever  $f \leq 95$  (5Fh). See [Section 23.2.3 "Byte-Oriented and Bit-Oriented Instructions in Indexed Literal Offset Mode"](#) for details.

Words:      1

Cycles:      1(2)  
**Note:** 3 cycles if skip and followed by a 2-word instruction.

Q Cycle Activity:

Q1	Q2	Q3	Q4
Decode	Read register 'f'	Process Data	Write to destination

If skip:

Q1	Q2	Q3	Q4
No operation	No operation	No operation	No operation

If skip and followed by 2-word instruction:

Q1	Q2	Q3	Q4
No operation	No operation	No operation	No operation
No operation	No operation	No operation	No operation

**Example:**

```

HERE      DECFSZ    CNT, 1, 1
            GOTO      LOOP
            CONTINUE
  
```

Before Instruction  
 PC = Address (HERE)

After Instruction  
 CNT = CNT - 1  
 If CNT = 0;  
 PC = Address (CONTINUE)  
 If CNT ≠ 0;  
 PC = Address (HERE + 2)

**DCFSNZ**      **Decrement f, skip if not 0**

Syntax:      DCFSNZ f {,d {,a}}

Operands:     $0 \leq f \leq 255$   
 $d \in [0,1]$   
 $a \in [0,1]$

Operation:    (f) – 1 → dest,  
 skip if result ≠ 0

Status Affected:    None

Encoding:    

0100	11da	ffff	ffff
------	------	------	------

Description:    The contents of register 'f' are decremented. If 'd' is '0', the result is placed in W. If 'd' is '1', the result is placed back in register 'f' (default). If the result is not '0', the next instruction, which is already fetched, is discarded and a NOP is executed instead, making it a two-cycle instruction. If 'a' is '0', the Access Bank is selected. If 'a' is '1', the BSR is used to select the GPR bank (default). If 'a' is '0' and the extended instruction set is enabled, this instruction operates in Indexed Literal Offset Addressing mode whenever  $f \leq 95$  (5Fh). See [Section 23.2.3 "Byte-Oriented and Bit-Oriented Instructions in Indexed Literal Offset Mode"](#) for details.

Words:      1

Cycles:      1(2)  
**Note:** 3 cycles if skip and followed by a 2-word instruction.

Q Cycle Activity:

Q1	Q2	Q3	Q4
Decode	Read register 'f'	Process Data	Write to destination

If skip:

Q1	Q2	Q3	Q4
No operation	No operation	No operation	No operation

If skip and followed by 2-word instruction:

Q1	Q2	Q3	Q4
No operation	No operation	No operation	No operation
No operation	No operation	No operation	No operation

**Example:**

```

HERE      DCFSNZ    TEMP, 1, 0
ZERO      :
NZERO     :
  
```

Before Instruction  
 TEMP = ?

After Instruction  
 TEMP = TEMP – 1,  
 If TEMP = 0;  
 PC = Address (ZERO)  
 If TEMP ≠ 0;  
 PC = Address (NZERO)

# PIC18(L)F1XK22

## GOTO Unconditional Branch

Syntax: GOTO k  
 Operands:  $0 \leq k \leq 1048575$   
 Operation:  $k \rightarrow PC<20:1>$   
 Status Affected: None

Encoding:  
 1st word (k<7:0>)  
 2nd word(k<19:8>)

1110	1111	k <sub>7</sub> kkk	kkkk <sub>0</sub>
1111	k <sub>19</sub> kkk	kkkk	kkkk <sub>8</sub>

Description: GOTO allows an unconditional branch anywhere within entire 2-Mbyte memory range. The 20-bit value 'k' is loaded into PC<20:1>. GOTO is always a two-cycle instruction.

Words: 2  
 Cycles: 2

Q Cycle Activity:

Q1	Q2	Q3	Q4
Decode	Read literal 'k'<7:0>.	No operation	Read literal 'k'<19:8>, Write to PC
No operation	No operation	No operation	No operation

Example: GOTO THERE  
 After Instruction  
 PC = Address (THERE)

## INCF Increment f

Syntax: INCF f,{d {,a}}  
 Operands:  $0 \leq f \leq 255$   
 $d \in [0,1]$   
 $a \in [0,1]$

Operation:  $(f) + 1 \rightarrow \text{dest}$   
 Status Affected: C, DC, N, OV, Z

Encoding:

0010	10da	ffff	ffff
------	------	------	------

Description: The contents of register 'f' are incremented. If 'd' is '0', the result is placed in W. If 'd' is '1', the result is placed back in register 'f' (default). If 'a' is '0', the Access Bank is selected. If 'a' is '1', the BSR is used to select the GPR bank (default). If 'a' is '0' and the extended instruction set is enabled, this instruction operates in Indexed Literal Offset Addressing mode whenever  $f \leq 95$  (5Fh). See [Section 23.2.3 "Byte-Oriented and Bit-Oriented Instructions in Indexed Literal Offset Mode"](#) for details.

Words: 1  
 Cycles: 1

Q Cycle Activity:

Q1	Q2	Q3	Q4
Decode	Read register 'f'	Process Data	Write to destination

Example: INCF CNT, 1, 0

Before Instruction  
 CNT = FFh  
 Z = 0  
 C = ?  
 DC = ?

After Instruction  
 CNT = 00h  
 Z = 1  
 C = 1  
 DC = 1

**INCFSZ**      **Increment f, skip if 0**

---

Syntax:            INCFSZ f {,d {,a}}

Operands:         $0 \leq f \leq 255$   
 $d \in [0,1]$   
 $a \in [0,1]$

Operation:         $(f) + 1 \rightarrow \text{dest}$ ,  
skip if result = 0

Status Affected:    None

Encoding:        

0011	11da	ffff	ffff
------	------	------	------

Description:      The contents of register 'f' are incremented. If 'd' is '0', the result is placed in W. If 'd' is '1', the result is placed back in register 'f' (default). If the result is '0', the next instruction, which is already fetched, is discarded and a NOP is executed instead, making it a two-cycle instruction. If 'a' is '0', the Access Bank is selected. If 'a' is '1', the BSR is used to select the GPR bank (default). If 'a' is '0' and the extended instruction set is enabled, this instruction operates in Indexed Literal Offset Addressing mode whenever  $f \leq 95$  (5Fh). See [Section 23.2.3 "Byte-Oriented and Bit-Oriented Instructions in Indexed Literal Offset Mode"](#) for details.

Words:            1

Cycles:            1(2)  
**Note:** 3 cycles if skip and followed by a 2-word instruction.

Q Cycle Activity:

Q1	Q2	Q3	Q4
Decode	Read register 'f'	Process Data	Write to destination

If skip:

Q1	Q2	Q3	Q4
No operation	No operation	No operation	No operation

If skip and followed by 2-word instruction:

Q1	Q2	Q3	Q4
No operation	No operation	No operation	No operation
No operation	No operation	No operation	No operation

**Example:**            HERE      INCFSZ    CNT, 1, 0  
NZERO    :  
ZERO     :

Before Instruction  
PC = Address (HERE)

After Instruction  
CNT = CNT + 1  
If CNT = 0;  
PC = Address (ZERO)  
If CNT  $\neq$  0;  
PC = Address (NZERO)

**INFSNZ**      **Increment f, skip if not 0**

---

Syntax:            INFSNZ f {,d {,a}}

Operands:         $0 \leq f \leq 255$   
 $d \in [0,1]$   
 $a \in [0,1]$

Operation:         $(f) + 1 \rightarrow \text{dest}$ ,  
skip if result  $\neq$  0

Status Affected:    None

Encoding:        

0100	10da	ffff	ffff
------	------	------	------

Description:      The contents of register 'f' are incremented. If 'd' is '0', the result is placed in W. If 'd' is '1', the result is placed back in register 'f' (default). If the result is not '0', the next instruction, which is already fetched, is discarded and a NOP is executed instead, making it a two-cycle instruction. If 'a' is '0', the Access Bank is selected. If 'a' is '1', the BSR is used to select the GPR bank (default). If 'a' is '0' and the extended instruction set is enabled, this instruction operates in Indexed Literal Offset Addressing mode whenever  $f \leq 95$  (5Fh). See [Section 23.2.3 "Byte-Oriented and Bit-Oriented Instructions in Indexed Literal Offset Mode"](#) for details.

Words:            1

Cycles:            1(2)  
**Note:** 3 cycles if skip and followed by a 2-word instruction.

Q Cycle Activity:

Q1	Q2	Q3	Q4
Decode	Read register 'f'	Process Data	Write to destination

If skip:

Q1	Q2	Q3	Q4
No operation	No operation	No operation	No operation

If skip and followed by 2-word instruction:

Q1	Q2	Q3	Q4
No operation	No operation	No operation	No operation
No operation	No operation	No operation	No operation

**Example:**            HERE      INFSNZ    REG, 1, 0  
ZERO     :  
NZERO    :

Before Instruction  
PC = Address (HERE)

After Instruction  
REG = REG + 1  
If REG  $\neq$  0;  
PC = Address (NZERO)  
If REG = 0;  
PC = Address (ZERO)

# PIC18(L)F1XK22

## IORLW Inclusive OR literal with W

Syntax: IORLW k

Operands:  $0 \leq k \leq 255$

Operation: (W) .OR. k  $\rightarrow$  W

Status Affected: N, Z

Encoding: 

0000	1001	kkkk	kkkk
------	------	------	------

Description: The contents of W are ORed with the eight-bit literal 'k'. The result is placed in W.

Words: 1

Cycles: 1

Q Cycle Activity:

Q1	Q2	Q3	Q4
Decode	Read literal 'k'	Process Data	Write to W

**Example:** IORLW 35h

Before Instruction

W = 9Ah

After Instruction

W = BFh

## IORWF Inclusive OR W with f

Syntax: IORWF f {,d {,a}}

Operands:  $0 \leq f \leq 255$   
 $d \in [0,1]$   
 $a \in [0,1]$

Operation: (W) .OR. (f)  $\rightarrow$  dest

Status Affected: N, Z

Encoding: 

0001	00da	ffff	ffff
------	------	------	------

Description: Inclusive OR W with register 'f'. If 'd' is '0', the result is placed in W. If 'd' is '1', the result is placed back in register 'f' (default).  
 If 'a' is '0', the Access Bank is selected. If 'a' is '1', the BSR is used to select the GPR bank (default).  
 If 'a' is '0' and the extended instruction set is enabled, this instruction operates in Indexed Literal Offset Addressing mode whenever  $f \leq 95$  (5Fh). See [Section 23.2.3 "Byte-Oriented and Bit-Oriented Instructions in Indexed Literal Offset Mode"](#) for details.

Words: 1

Cycles: 1

Q Cycle Activity:

Q1	Q2	Q3	Q4
Decode	Read register 'f'	Process Data	Write to destination

**Example:** IORWF RESULT, 0, 1

Before Instruction

RESULT = 13h

W = 91h

After Instruction

RESULT = 13h

W = 93h



# PIC18(L)F1XK22

LFSR	Load FSR															
Syntax:	LFSR f, k															
Operands:	$0 \leq f \leq 2$ $0 \leq k \leq 4095$															
Operation:	$k \rightarrow \text{FSRf}$															
Status Affected:	None															
Encoding:	<table border="1"> <tr> <td>1110</td> <td>1110</td> <td>00ff</td> <td><math>k_{11}kkk</math></td> </tr> <tr> <td>1111</td> <td>0000</td> <td><math>k_7kkk</math></td> <td><math>kkkk</math></td> </tr> </table>	1110	1110	00ff	$k_{11}kkk$	1111	0000	$k_7kkk$	$kkkk$							
1110	1110	00ff	$k_{11}kkk$													
1111	0000	$k_7kkk$	$kkkk$													
Description:	The 12-bit literal 'k' is loaded into the File Select Register pointed to by 'f'.															
Words:	2															
Cycles:	2															
Q Cycle Activity:	<table border="1"> <thead> <tr> <th></th> <th>Q1</th> <th>Q2</th> <th>Q3</th> <th>Q4</th> </tr> </thead> <tbody> <tr> <td>Decode</td> <td></td> <td>Read literal 'k' MSB</td> <td>Process Data</td> <td>Write literal 'k' MSB to FSRfH</td> </tr> <tr> <td>Decode</td> <td></td> <td>Read literal 'k' LSB</td> <td>Process Data</td> <td>Write literal 'k' to FSRfL</td> </tr> </tbody> </table>		Q1	Q2	Q3	Q4	Decode		Read literal 'k' MSB	Process Data	Write literal 'k' MSB to FSRfH	Decode		Read literal 'k' LSB	Process Data	Write literal 'k' to FSRfL
	Q1	Q2	Q3	Q4												
Decode		Read literal 'k' MSB	Process Data	Write literal 'k' MSB to FSRfH												
Decode		Read literal 'k' LSB	Process Data	Write literal 'k' to FSRfL												

**Example:** LFSR 2, 3ABh

After Instruction  
 FSR2H = 03h  
 FSR2L = ABh

MOVF	Move f										
Syntax:	MOVF f {,d {,a}}										
Operands:	$0 \leq f \leq 255$ $d \in [0,1]$ $a \in [0,1]$										
Operation:	$f \rightarrow \text{dest}$										
Status Affected:	N, Z										
Encoding:	<table border="1"> <tr> <td>0101</td> <td>00da</td> <td>ffff</td> <td>ffff</td> </tr> </table>	0101	00da	ffff	ffff						
0101	00da	ffff	ffff								
Description:	The contents of register 'f' are moved to a destination dependent upon the status of 'd'. If 'd' is '0', the result is placed in W. If 'd' is '1', the result is placed back in register 'f' (default). Location 'f' can be anywhere in the 256-byte bank. If 'a' is '0', the Access Bank is selected. If 'a' is '1', the BSR is used to select the GPR bank (default). If 'a' is '0' and the extended instruction set is enabled, this instruction operates in Indexed Literal Offset Addressing mode whenever $f \leq 95$ (5Fh). See <a href="#">Section 23.2.3 "Byte-Oriented and Bit-Oriented Instructions in Indexed Literal Offset Mode"</a> for details.										
Words:	1										
Cycles:	1										
Q Cycle Activity:	<table border="1"> <thead> <tr> <th></th> <th>Q1</th> <th>Q2</th> <th>Q3</th> <th>Q4</th> </tr> </thead> <tbody> <tr> <td>Decode</td> <td></td> <td>Read register 'f'</td> <td>Process Data</td> <td>Write W</td> </tr> </tbody> </table>		Q1	Q2	Q3	Q4	Decode		Read register 'f'	Process Data	Write W
	Q1	Q2	Q3	Q4							
Decode		Read register 'f'	Process Data	Write W							

**Example:** MOVF REG, 0, 0

Before Instruction  
 REG = 22h  
 W = FFh  
 After Instruction  
 REG = 22h  
 W = 22h

# PIC18(L)F1XK22

## MOVFF Move f to f

**Syntax:** MOVFF  $f_s, f_d$

**Operands:**  $0 \leq f_s \leq 4095$   
 $0 \leq f_d \leq 4095$

**Operation:**  $(f_s) \rightarrow f_d$

**Status Affected:** None

**Encoding:**

1100	ffff	ffff	ffff <sub>s</sub>
1111	ffff	ffff	ffff <sub>d</sub>

**1st word (source)**  
**2nd word (destin.)**

**Description:** The contents of source register 'f<sub>s</sub>' are moved to destination register 'f<sub>d</sub>'. Location of source 'f<sub>s</sub>' can be anywhere in the 4096-byte data space (000h to FFFh) and location of destination 'f<sub>d</sub>' can also be anywhere from 000h to FFFh. Either source or destination can be W (a useful special situation). MOVFF is particularly useful for transferring a data memory location to a peripheral register (such as the transmit buffer or an I/O port). The MOVFF instruction cannot use the PCL, TOSU, TOSH or TOSL as the destination register.

**Words:** 2

**Cycles:** 2 (3)

**Q Cycle Activity:**

Q1	Q2	Q3	Q4
Decode	Read register 'f' (src)	Process Data	No operation
Decode	No operation No dummy read	No operation	Write register 'f' (dest)

**Example:** MOVFF REG1, REG2

**Before Instruction**  
 REG1 = 33h  
 REG2 = 11h

**After Instruction**  
 REG1 = 33h  
 REG2 = 33h

## MOVLB Move literal to low nibble in BSR

**Syntax:** MOVLB k

**Operands:**  $0 \leq k \leq 255$

**Operation:**  $k \rightarrow \text{BSR}$

**Status Affected:** None

**Encoding:**

0000	0001	0000	kkkk
------	------	------	------

**Description:** The eight-bit literal 'k' is loaded into the Bank Select Register (BSR). The value of BSR<7:4> always remains '0', regardless of the value of k<sub>7:k4</sub>.

**Words:** 1

**Cycles:** 1

**Q Cycle Activity:**

Q1	Q2	Q3	Q4
Decode	Read literal 'k'	Process Data	Write literal 'k' to BSR

**Example:** MOVLB 5

**Before Instruction**  
 BSR Register = 02h

**After Instruction**  
 BSR Register = 05h

# PIC18(L)F1XK22

## MOVLW Move literal to W

Syntax: MOVLW k

Operands:  $0 \leq k \leq 255$

Operation:  $k \rightarrow W$

Status Affected: None

Encoding: 

0000	1110	kkkk	kkkk
------	------	------	------

Description: The eight-bit literal 'k' is loaded into W.

Words: 1

Cycles: 1

Q Cycle Activity:

Q1	Q2	Q3	Q4
Decode	Read literal 'k'	Process Data	Write to W

**Example:** MOVLW 5Ah

After Instruction

W = 5Ah

## MOVWF Move W to f

Syntax: MOVWF f{,a}

Operands:  $0 \leq f \leq 255$   
 $a \in [0,1]$

Operation:  $(W) \rightarrow f$

Status Affected: None

Encoding: 

0110	111a	ffff	ffff
------	------	------	------

Description: Move data from W to register 'f'. Location 'f' can be anywhere in the 256-byte bank.

If 'a' is '0', the Access Bank is selected. If 'a' is '1', the BSR is used to select the GPR bank (default). If 'a' is '0' and the extended instruction set is enabled, this instruction operates in Indexed Literal Offset Addressing mode whenever  $f \leq 95$  (5Fh). See [Section 23.2.3 "Byte-Oriented and Bit-Oriented Instructions in Indexed Literal Offset Mode"](#) for details.

Words: 1

Cycles: 1

Q Cycle Activity:

Q1	Q2	Q3	Q4
Decode	Read register 'f'	Process Data	Write register 'f'

**Example:** MOVWF REG, 0

Before Instruction

W = 4Fh  
REG = FFh

After Instruction

W = 4Fh  
REG = 4Fh

# PIC18(L)F1XK22

## MULLW Multiply literal with W

**Syntax:** MULLW k

**Operands:**  $0 \leq k \leq 255$

**Operation:**  $(W) \times k \rightarrow \text{PRODH}:\text{PRODL}$

**Status Affected:** None

**Encoding:**

0000	1101	kkkk	kkkk
------	------	------	------

**Description:** An unsigned multiplication is carried out between the contents of W and the 8-bit literal 'k'. The 16-bit result is placed in the PRODH:PRODL register pair. PRODH contains the high byte. W is unchanged.  
None of the Status flags are affected. Note that neither overflow nor carry is possible in this operation. A zero result is possible but not detected.

**Words:** 1

**Cycles:** 1

**Q Cycle Activity:**

Q1	Q2	Q3	Q4
Decode	Read literal 'k'	Process Data	Write registers PRODH:PRODL

**Example:** MULLW 0C4h

**Before Instruction**

W = E2h  
 PRODH = ?  
 PRODL = ?

**After Instruction**

W = E2h  
 PRODH = ADh  
 PRODL = 08h

## MULWF Multiply W with f

**Syntax:** MULWF f{,a}

**Operands:**  $0 \leq f \leq 255$   
 $a \in [0,1]$

**Operation:**  $(W) \times (f) \rightarrow \text{PRODH}:\text{PRODL}$

**Status Affected:** None

**Encoding:**

0000	001a	ffff	ffff
------	------	------	------

**Description:** An unsigned multiplication is carried out between the contents of W and the register file location 'f'. The 16-bit result is stored in the PRODH:PRODL register pair. PRODH contains the high byte. Both W and 'f' are unchanged.  
None of the Status flags are affected. Note that neither overflow nor carry is possible in this operation. A zero result is possible but not detected. If 'a' is '0', the Access Bank is selected. If 'a' is '1', the BSR is used to select the GPR bank (default). If 'a' is '0' and the extended instruction set is enabled, this instruction operates in Indexed Literal Offset Addressing mode whenever  $f \leq 95$  (5Fh). See [Section 23.2.3 "Byte-Oriented and Bit-Oriented Instructions in Indexed Literal Offset Mode"](#) for details.

**Words:** 1

**Cycles:** 1

**Q Cycle Activity:**

Q1	Q2	Q3	Q4
Decode	Read register 'f'	Process Data	Write registers PRODH:PRODL

**Example:** MULWF REG, 1

**Before Instruction**

W = C4h  
 REG = B5h  
 PRODH = ?  
 PRODL = ?

**After Instruction**

W = C4h  
 REG = B5h  
 PRODH = 8Ah  
 PRODL = 94h

## NEGF

## Negate f

**Syntax:** NEGF f{,a}

**Operands:**  $0 \leq f \leq 255$   
 $a \in [0,1]$

**Operation:**  $(\bar{f}) + 1 \rightarrow f$

**Status Affected:** N, OV, C, DC, Z

**Encoding:**

0110	110a	ffff	ffff
------	------	------	------

**Description:** Location 'f' is negated using two's complement. The result is placed in the data memory location 'f'. If 'a' is '0', the Access Bank is selected. If 'a' is '1', the BSR is used to select the GPR bank (default). If 'a' is '0' and the extended instruction set is enabled, this instruction operates in Indexed Literal Offset Addressing mode whenever  $f \leq 95$  (5Fh). See [Section 23.2.3 "Byte-Oriented and Bit-Oriented Instructions in Indexed Literal Offset Mode"](#) for details.

**Words:** 1

**Cycles:** 1

Q Cycle Activity:

Q1	Q2	Q3	Q4
Decode	Read register 'f'	Process Data	Write register 'f'

**Example:** NEGF REG, 1

Before Instruction

REG = 0011 1010 [3Ah]

After Instruction

REG = 1100 0110 [C6h]

## NOP

## No Operation

**Syntax:** NOP

**Operands:** None

**Operation:** No operation

**Status Affected:** None

**Encoding:**

0000	0000	0000	0000
1111	xxxx	xxxx	xxxx

**Description:** No operation.

**Words:** 1

**Cycles:** 1

Q Cycle Activity:

Q1	Q2	Q3	Q4
Decode	No operation	No operation	No operation

**Example:**

None.

# PIC18(L)F1XK22

## POP Pop Top of Return Stack

Syntax: POP

Operands: None

Operation: (TOS) → bit bucket

Status Affected: None

Encoding: 

0000	0000	0000	0110
------	------	------	------

Description: The TOS value is pulled off the return stack and is discarded. The TOS value then becomes the previous value that was pushed onto the return stack. This instruction is provided to enable the user to properly manage the return stack to incorporate a software stack.

Words: 1

Cycles: 1

Q Cycle Activity:

Q1	Q2	Q3	Q4
Decode	No operation	POP TOS value	No operation

**Example:** POP GOTO NEW

Before Instruction		
TOS	=	0031A2h
Stack (1 level down)	=	014332h
After Instruction		
TOS	=	014332h
PC	=	NEW

## PUSH Push Top of Return Stack

Syntax: PUSH

Operands: None

Operation: (PC + 2) → TOS

Status Affected: None

Encoding: 

0000	0000	0000	0101
------	------	------	------

Description: The PC + 2 is pushed onto the top of the return stack. The previous TOS value is pushed down on the stack. This instruction allows implementing a software stack by modifying TOS and then pushing it onto the return stack.

Words: 1

Cycles: 1

Q Cycle Activity:

Q1	Q2	Q3	Q4
Decode	PUSH PC + 2 onto return stack	No operation	No operation

**Example:** PUSH

Before Instruction		
TOS	=	345Ah
PC	=	0124h
After Instruction		
PC	=	0126h
TOS	=	0126h
Stack (1 level down)	=	345Ah

# PIC18(L)F1XK22

**RCALL**                      **Relative Call**

---

Syntax:                      RCALL n

Operands:                     $-1024 \leq n \leq 1023$

Operation:                    (PC) + 2 → TOS,  
(PC) + 2 + 2n → PC

Status Affected:            None

Encoding:                    

1101	1nnn	nnnn	nnnn
------	------	------	------

Description:                Subroutine call with a jump up to 1K from the current location. First, return address (PC + 2) is pushed onto the stack. Then, add the 2's complement number '2n' to the PC. Since the PC will have incremented to fetch the next instruction, the new address will be PC + 2 + 2n. This instruction is a two-cycle instruction.

Words:                        1

Cycles:                        2

Q Cycle Activity:

Q1	Q2	Q3	Q4
Decode	Read literal 'n' PUSH PC to stack	Process Data	Write to PC
No operation	No operation	No operation	No operation

**Example:**                    HERE            RCALL Jump

Before Instruction

PC = Address (HERE)

After Instruction

PC = Address (Jump)

TOS = Address (HERE + 2)

**RESET**                      **Reset**

---

Syntax:                      RESET

Operands:                    None

Operation:                    Reset all registers and flags that are affected by a  $\overline{\text{MCLR}}$  Reset.

Status Affected:            All

Encoding:                    

0000	0000	1111	1111
------	------	------	------

Description:                This instruction provides a way to execute a  $\overline{\text{MCLR}}$  Reset by software.

Words:                        1

Cycles:                        1

Q Cycle Activity:

Q1	Q2	Q3	Q4
Decode	Start Reset	No operation	No operation

**Example:**                    RESET

After Instruction

Registers = Reset Value

Flags\* = Reset Value

# PIC18(L)F1XK22

## RETFIE Return from Interrupt

**Syntax:** RETFIE {s}

**Operands:**  $s \in [0,1]$

**Operation:** (TOS) → PC,  
 $1 \rightarrow$  GIE/GIEH or PEIE/GIEL,  
 if  $s = 1$   
 (WS) → W,  
 (STATUS) → Status,  
 (BSRS) → BSR,  
 PCLATU, PCLATH are unchanged.

**Status Affected:** GIE/GIEH, PEIE/GIEL

**Encoding:**

0000	0000	0001	000s
------	------	------	------

**Description:** Return from interrupt. Stack is popped and Top-of-Stack (TOS) is loaded into the PC. Interrupts are enabled by setting either the high or low priority global interrupt enable bit. If 's' = 1, the contents of the shadow registers, WS, STATUS and BSRs, are loaded into their corresponding registers, W, Status and BSR. If 's' = 0, no update of these registers occurs (default).

**Words:** 1

**Cycles:** 2

**Q Cycle Activity:**

Q1	Q2	Q3	Q4
Decode	No operation	No operation	POP PC from stack Set GIEH or GIEL
No operation	No operation	No operation	No operation

**Example:** RETFIE 1

After Interrupt

PC	=	TOS
W	=	WS
BSR	=	BSRS
Status	=	STATUS
GIE/GIEH, PEIE/GIEL	=	1

## RETLW Return literal to W

**Syntax:** RETLW k

**Operands:**  $0 \leq k \leq 255$

**Operation:**  $k \rightarrow$  W,  
 (TOS) → PC,  
 PCLATU, PCLATH are unchanged

**Status Affected:** None

**Encoding:**

0000	1100	kkkk	kkkk
------	------	------	------

**Description:** W is loaded with the eight-bit literal 'k'. The program counter is loaded from the top of the stack (the return address). The high address latch (PCLATH) remains unchanged.

**Words:** 1

**Cycles:** 2

**Q Cycle Activity:**

Q1	Q2	Q3	Q4
Decode	Read literal 'k'	Process Data	POP PC from stack, Write to W
No operation	No operation	No operation	No operation

### Example:

```
CALL TABLE ; W contains table
              ; offset value
              ; W now has
              ; table value
:
TABLE
  ADDWF PCL ; W = offset
  RETLW k0 ; Begin table
  RETLW k1 ;
:
:
  RETLW kn ; End of table
```

Before Instruction  
 W = 07h

After Instruction  
 W = value of kn



# PIC18(L)F1XK22

**RETURN**      **Return from Subroutine**

---

Syntax:            RETURN {s}

Operands:        s ∈ [0,1]

Operation:        (TOS) → PC,  
if s = 1  
(WS) → W,  
(STATUS) → Status,  
(BSRS) → BSR,  
PCLATU, PCLATH are unchanged

Status Affected:    None

Encoding:        

0000	0000	0001	001s
------	------	------	------

Description:      Return from subroutine. The stack is popped and the top of the stack (TOS) is loaded into the program counter. If 's' = 1, the contents of the shadow registers, WS, STATUS and BSRS, are loaded into their corresponding registers, W, Status and BSR. If 's' = 0, no update of these registers occurs (default).

Words:            1

Cycles:            2

Q Cycle Activity:

	Q1	Q2	Q3	Q4
Decode	No operation	Process Data	POP PC from stack	
No operation	No operation	No operation	No operation	

**Example:**            RETURN

After Instruction:  
PC = TOS

**RLCF**            **Rotate Left f through Carry**

---

Syntax:            RLCF f {,d {,a}}

Operands:        0 ≤ f ≤ 255  
d ∈ [0,1]  
a ∈ [0,1]

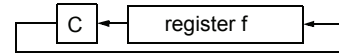
Operation:        (f<n>) → dest<n + 1>,  
(f<7>) → C,  
(C) → dest<0>

Status Affected:    C, N, Z

Encoding:        

0011	01da	ffff	ffff
------	------	------	------

Description:      The contents of register 'f' are rotated one bit to the left through the CARRY flag. If 'd' is '0', the result is placed in W. If 'd' is '1', the result is stored back in register 'f' (default).  
If 'a' is '0', the Access Bank is selected. If 'a' is '1', the BSR is used to select the GPR bank (default).  
If 'a' is '0' and the extended instruction set is enabled, this instruction operates in Indexed Literal Offset Addressing mode whenever f ≤ 95 (5Fh). See [Section 23.2.3 "Byte-Oriented and Bit-Oriented Instructions in Indexed Literal Offset Mode"](#) for details.



Words:            1

Cycles:            1

Q Cycle Activity:

	Q1	Q2	Q3	Q4
Decode	Read register 'f'	Process Data	Write to destination	

**Example:**            RLCF REG, 0, 0

Before Instruction  
REG = 1110 0110  
C = 0

After Instruction  
REG = 1110 0110  
W = 1100 1100  
C = 1

# PIC18(L)F1XK22

## RLNCF Rotate Left f (No Carry)

Syntax: RLNCF f{,d{,a}}

Operands:  $0 \leq f \leq 255$   
 $d \in [0,1]$   
 $a \in [0,1]$

Operation:  $(f\langle n \rangle) \rightarrow \text{dest}\langle n + 1 \rangle$ ,  
 $(f\langle 7 \rangle) \rightarrow \text{dest}\langle 0 \rangle$

Status Affected: N, Z

Encoding: 

0100	01da	ffff	ffff
------	------	------	------

Description: The contents of register 'f' are rotated one bit to the left. If 'd' is '0', the result is placed in W. If 'd' is '1', the result is stored back in register 'f' (default). If 'a' is '0', the Access Bank is selected. If 'a' is '1', the BSR is used to select the GPR bank (default). If 'a' is '0' and the extended instruction set is enabled, this instruction operates in Indexed Literal Offset Addressing mode whenever  $f \leq 95$  (5Fh). See [Section 23.2.3 "Byte-Oriented and Bit-Oriented Instructions in Indexed Literal Offset Mode"](#) for details.



Words: 1

Cycles: 1

Q Cycle Activity:

Q1	Q2	Q3	Q4
Decode	Read register 'f'	Process Data	Write to destination

Example: RLNCF REG, 1, 0

Before Instruction  
REG = 1010 1011  
After Instruction  
REG = 0101 0111

## RRCF Rotate Right f through Carry

Syntax: RRCF f{,d{,a}}

Operands:  $0 \leq f \leq 255$   
 $d \in [0,1]$   
 $a \in [0,1]$

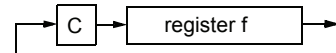
Operation:  $(f\langle n \rangle) \rightarrow \text{dest}\langle n - 1 \rangle$ ,  
 $(f\langle 0 \rangle) \rightarrow C$ ,  
 $(C) \rightarrow \text{dest}\langle 7 \rangle$

Status Affected: C, N, Z

Encoding: 

0011	00da	ffff	ffff
------	------	------	------

Description: The contents of register 'f' are rotated one bit to the right through the CARRY flag. If 'd' is '0', the result is placed in W. If 'd' is '1', the result is placed back in register 'f' (default). If 'a' is '0', the Access Bank is selected. If 'a' is '1', the BSR is used to select the GPR bank (default). If 'a' is '0' and the extended instruction set is enabled, this instruction operates in Indexed Literal Offset Addressing mode whenever  $f \leq 95$  (5Fh). See [Section 23.2.3 "Byte-Oriented and Bit-Oriented Instructions in Indexed Literal Offset Mode"](#) for details.



Words: 1

Cycles: 1

Q Cycle Activity:

Q1	Q2	Q3	Q4
Decode	Read register 'f'	Process Data	Write to destination

Example: RRCF REG, 0, 0

Before Instruction  
REG = 1110 0110  
C = 0  
After Instruction  
REG = 1110 0110  
W = 0111 0011  
C = 0

**RRNCF**      **Rotate Right f (No Carry)**

---

Syntax:            RRNCF f {,d {,a}}

Operands:         $0 \leq f \leq 255$   
 $d \in [0,1]$   
 $a \in [0,1]$

Operation:         $(f<n>) \rightarrow \text{dest}<n - 1>$ ,  
 $(f<0>) \rightarrow \text{dest}<7>$

Status Affected: N, Z

Encoding:        

0100	00da	ffff	ffff
------	------	------	------

Description:     The contents of register 'f' are rotated one bit to the right. If 'd' is '0', the result is placed in W. If 'd' is '1', the result is placed back in register 'f' (default). If 'a' is '0', the Access Bank will be selected, overriding the BSR value. If 'a' is '1', then the bank will be selected as per the BSR value (default). If 'a' is '0' and the extended instruction set is enabled, this instruction operates in Indexed Literal Offset Addressing mode whenever  $f \leq 95$  (5Fh). See [Section 23.2.3 "Byte-Oriented and Bit-Oriented Instructions in Indexed Literal Offset Mode"](#) for details.

Words:            1

Cycles:           1

Q Cycle Activity:

Q1	Q2	Q3	Q4
Decode	Read register 'f'	Process Data	Write to destination

**Example 1:**            RRNCF REG, 1, 0

Before Instruction  
REG = 1101 0111  
After Instruction  
REG = 1110 1011

**Example 2:**            RRNCF REG, 0, 0

Before Instruction  
W = ?  
REG = 1101 0111  
After Instruction  
W = 1110 1011  
REG = 1101 0111

**SETF**            **Set f**

---

Syntax:            SETF f {,a}

Operands:         $0 \leq f \leq 255$   
 $a \in [0,1]$

Operation:         $FFh \rightarrow f$

Status Affected: None

Encoding:        

0110	100a	ffff	ffff
------	------	------	------

Description:     The contents of the specified register are set to FFh. If 'a' is '0', the Access Bank is selected. If 'a' is '1', the BSR is used to select the GPR bank (default). If 'a' is '0' and the extended instruction set is enabled, this instruction operates in Indexed Literal Offset Addressing mode whenever  $f \leq 95$  (5Fh). See [Section 23.2.3 "Byte-Oriented and Bit-Oriented Instructions in Indexed Literal Offset Mode"](#) for details.

Words:            1

Cycles:           1

Q Cycle Activity:

Q1	Q2	Q3	Q4
Decode	Read register 'f'	Process Data	Write register 'f'

**Example:**            SETF REG, 1

Before Instruction  
REG = 5Ah  
After Instruction  
REG = FFh

# PIC18(L)F1XK22

## SLEEP Enter Sleep mode

Syntax: SLEEP

Operands: None

Operation: 00h → WDT,  
0 → WDT postscaler,  
1 →  $\overline{TO}$ ,  
0 →  $\overline{PD}$

Status Affected:  $\overline{TO}$ ,  $\overline{PD}$

Encoding: 

0000	0000	0000	0011
------	------	------	------

Description: The Power-down Status bit ( $\overline{PD}$ ) is cleared. The Time-out Status bit ( $\overline{TO}$ ) is set. Watchdog Timer and its postscaler are cleared. The processor is put into Sleep mode with the oscillator stopped.

Words: 1

Cycles: 1

Q Cycle Activity:

Q1	Q2	Q3	Q4
Decode	No operation	Process Data	Go to Sleep

**Example:** SLEEP

Before Instruction

$\overline{TO}$  = ?

$\overline{PD}$  = ?

After Instruction

$\overline{TO}$  = 1 †

$\overline{PD}$  = 0

† If WDT causes wake-up, this bit is cleared.

## SUBFWB Subtract f from W with borrow

Syntax: SUBFWB f {,d {,a}}

Operands:  $0 \leq f \leq 255$   
 $d \in [0,1]$   
 $a \in [0,1]$

Operation:  $(W) - (f) - (\overline{C}) \rightarrow \text{dest}$

Status Affected: N, OV, C, DC, Z

Encoding: 

0101	01da	ffff	ffff
------	------	------	------

Description: Subtract register 'f' and CARRY flag (borrow) from W (2's complement method). If 'd' is '0', the result is stored in W. If 'd' is '1', the result is stored in register 'f' (default). If 'a' is '0', the Access Bank is selected. If 'a' is '1', the BSR is used to select the GPR bank (default). If 'a' is '0' and the extended instruction set is enabled, this instruction operates in Indexed Literal Offset Addressing mode whenever  $f \leq 95$  (5Fh). See [Section 23.2.3 "Byte-Oriented and Bit-Oriented Instructions in Indexed Literal Offset Mode"](#) for details.

Words: 1

Cycles: 1

Q Cycle Activity:

Q1	Q2	Q3	Q4
Decode	Read register 'f'	Process Data	Write to destination

**Example 1:** SUBFWB REG, 1, 0

Before Instruction

REG = 3

W = 2

C = 1

After Instruction

REG = FF

W = 2

C = 0

Z = 0

N = 1 ; result is negative

**Example 2:** SUBFWB REG, 0, 0

Before Instruction

REG = 2

W = 5

C = 1

After Instruction

REG = 2

W = 3

C = 1

Z = 0

N = 0 ; result is positive

**Example 3:** SUBFWB REG, 1, 0

Before Instruction

REG = 1

W = 2

C = 0

After Instruction

REG = 0

W = 2

C = 1

Z = 1 ; result is zero

N = 0

**SUBLW**                      **Subtract W from literal**

---

Syntax:                      SUBLW k

Operands:                     $0 \leq k \leq 255$

Operation:                    $k - (W) \rightarrow W$

Status Affected:            N, OV, C, DC, Z

Encoding:                    

0000	1000	kkkk	kkkk
------	------	------	------

Description                    W is subtracted from the eight-bit literal 'k'. The result is placed in W.

Words:                        1

Cycles:                        1

Q Cycle Activity:

Q1	Q2	Q3	Q4
Decode	Read literal 'k'	Process Data	Write to W

**Example 1:**                    SUBLW 02h

Before Instruction  
W = 01h  
C = ?

After Instruction  
W = 01h  
C = 1 ; result is positive  
Z = 0  
N = 0

**Example 2:**                    SUBLW 02h

Before Instruction  
W = 02h  
C = ?

After Instruction  
W = 00h  
C = 1 ; result is zero  
Z = 1  
N = 0

**Example 3:**                    SUBLW 02h

Before Instruction  
W = 03h  
C = ?

After Instruction  
W = FFh ; (2's complement)  
C = 0 ; result is negative  
Z = 0  
N = 1

**SUBWF**                      **Subtract W from f**

---

Syntax:                      SUBWF f {,d {,a}}

Operands:                     $0 \leq f \leq 255$   
 $d \in [0,1]$   
 $a \in [0,1]$

Operation:                     $(f) - (W) \rightarrow \text{dest}$

Status Affected:            N, OV, C, DC, Z

Encoding:                    

0101	11da	ffff	ffff
------	------	------	------

Description:                    Subtract W from register 'f' (2's complement method). If 'd' is '0', the result is stored in W. If 'd' is '1', the result is stored back in register 'f' (default).  
If 'a' is '0', the Access Bank is selected. If 'a' is '1', the BSR is used to select the GPR bank (default).  
If 'a' is '0' and the extended instruction set is enabled, this instruction operates in Indexed Literal Offset Addressing mode whenever  $f \leq 95$  (5Fh). See [Section 23.2.3 "Byte-Oriented and Bit-Oriented Instructions in Indexed Literal Offset Mode"](#) for details.

Words:                        1

Cycles:                        1

Q Cycle Activity:

Q1	Q2	Q3	Q4
Decode	Read register 'f'	Process Data	Write to destination

**Example 1:**                    SUBWF REG, 1, 0

Before Instruction  
REG = 3  
W = 2  
C = ?

After Instruction  
REG = 1  
W = 2  
C = 1 ; result is positive  
Z = 0  
N = 0

**Example 2:**                    SUBWF REG, 0, 0

Before Instruction  
REG = 2  
W = 2  
C = ?

After Instruction  
REG = 2  
W = 0  
C = 1 ; result is zero  
Z = 1  
N = 0

**Example 3:**                    SUBWF REG, 1, 0

Before Instruction  
REG = 1  
W = 2  
C = ?

After Instruction  
REG = FFh ;(2's complement)  
W = 2  
C = 0 ; result is negative  
Z = 0  
N = 1

# PIC18(L)F1XK22

## SUBWFB Subtract W from f with Borrow

Syntax: SUBWFB f{,d{,a}}

Operands:  $0 \leq f \leq 255$   
 $d \in [0,1]$   
 $a \in [0,1]$

Operation:  $(f) - (W) - (\overline{C}) \rightarrow \text{dest}$

Status Affected: N, OV, C, DC, Z

Encoding: 

0101	10da	ffff	ffff
------	------	------	------

Description: Subtract W and the CARRY flag (borrow) from register 'f' (2's complement method). If 'd' is '0', the result is stored in W. If 'd' is '1', the result is stored back in register 'f' (default). If 'a' is '0', the Access Bank is selected. If 'a' is '1', the BSR is used to select the GPR bank (default). If 'a' is '0' and the extended instruction set is enabled, this instruction operates in Indexed Literal Offset Addressing mode whenever  $f \leq 95$  (5Fh). See [Section 23.2.3 "Byte-Oriented and Bit-Oriented Instructions in Indexed Literal Offset Mode"](#) for details.

Words: 1  
 Cycles: 1  
 Q Cycle Activity:

Q1	Q2	Q3	Q4
Decode	Read register 'f'	Process Data	Write to destination

**Example 1:** SUBWFB REG, 1, 0

Before Instruction  
 REG = 19h (0001 1001)  
 W = 0Dh (0000 1101)  
 C = 1

After Instruction  
 REG = 0Ch (0000 1011)  
 W = 0Dh (0000 1101)  
 C = 1  
 Z = 0  
 N = 0 ; result is positive

**Example 2:** SUBWFB REG, 0, 0

Before Instruction  
 REG = 1Bh (0001 1011)  
 W = 1Ah (0001 1010)  
 C = 0

After Instruction  
 REG = 1Bh (0001 1011)  
 W = 00h  
 C = 1  
 Z = 1 ; result is zero  
 N = 0

**Example 3:** SUBWFB REG, 1, 0

Before Instruction  
 REG = 03h (0000 0011)  
 W = 0Eh (0000 1101)  
 C = 1

After Instruction  
 REG = F5h (1111 0100)  
 ; [2's comp]  
 W = 0Eh (0000 1101)  
 C = 0  
 Z = 0  
 N = 1 ; result is negative

## SWAPF Swap f

Syntax: SWAPF f{,d{,a}}

Operands:  $0 \leq f \leq 255$   
 $d \in [0,1]$   
 $a \in [0,1]$

Operation:  $(f<3:0>) \rightarrow \text{dest}<7:4>$ ,  
 $(f<7:4>) \rightarrow \text{dest}<3:0>$

Status Affected: None

Encoding: 

0011	10da	ffff	ffff
------	------	------	------

Description: The upper and lower nibbles of register 'f' are exchanged. If 'd' is '0', the result is placed in W. If 'd' is '1', the result is placed in register 'f' (default). If 'a' is '0', the Access Bank is selected. If 'a' is '1', the BSR is used to select the GPR bank (default). If 'a' is '0' and the extended instruction set is enabled, this instruction operates in Indexed Literal Offset Addressing mode whenever  $f \leq 95$  (5Fh). See [Section 23.2.3 "Byte-Oriented and Bit-Oriented Instructions in Indexed Literal Offset Mode"](#) for details.

Words: 1  
 Cycles: 1  
 Q Cycle Activity:

Q1	Q2	Q3	Q4
Decode	Read register 'f'	Process Data	Write to destination

**Example:** SWAPF REG, 1, 0

Before Instruction  
 REG = 53h

After Instruction  
 REG = 35h

## TBLRD Table Read

**Syntax:** TBLRD (\*; \*+; \*-; +\*)

**Operands:** None

**Operation:** if TBLRD \*,  
(Prog Mem (TBLPTR)) → TABLAT;  
TBLPTR – No Change;  
if TBLRD \*+,  
(Prog Mem (TBLPTR)) → TABLAT;  
(TBLPTR) + 1 → TBLPTR;  
if TBLRD \*-,  
(Prog Mem (TBLPTR)) → TABLAT;  
(TBLPTR) – 1 → TBLPTR;  
if TBLRD +\*,  
(TBLPTR) + 1 → TBLPTR;  
(Prog Mem (TBLPTR)) → TABLAT;

**Status Affected:** None

Encoding:	0000	0000	0000	10nn nn=0 * =1 *+ =2 *- =3 +*
-----------	------	------	------	---

**Description:** This instruction is used to read the contents of Program Memory (P.M.). To address the program memory, a pointer called Table Pointer (TBLPTR) is used. The TBLPTR (a 21-bit pointer) points to each byte in the program memory. TBLPTR has a 2-Mbyte address range.

TBLPTR[0] = 0: Least Significant Byte of Program Memory Word  
TBLPTR[0] = 1: Most Significant Byte of Program Memory Word

The TBLRD instruction can modify the value of TBLPTR as follows:

- no change
- post-increment
- post-decrement
- pre-increment

**Words:** 1

**Cycles:** 2

**Q Cycle Activity:**

	Q1	Q2	Q3	Q4
Decode	No operation	No operation	No operation	No operation
No operation	No operation (Read Program Memory)	No operation	No operation	No operation (Write TABLAT)

## TBLRD Table Read (Continued)

**Example1:** TBLRD \*+ ;

Before Instruction  
TABLAT = 55h  
TBLPTR = 00A356h  
MEMORY (00A356h) = 34h  
After Instruction  
TABLAT = 34h  
TBLPTR = 00A357h

**Example2:** TBLRD +\* ;

Before Instruction  
TABLAT = AAh  
TBLPTR = 01A357h  
MEMORY (01A357h) = 12h  
MEMORY (01A358h) = 34h  
After Instruction  
TABLAT = 34h  
TBLPTR = 01A358h

# PIC18(L)F1XK22

**TBLWT**      **Table Write**

---

Syntax:      TBLWT (\*, \*+, \*-; +\*)

Operands:    None

Operation:    if TBLWT\*,  
 (TABLAT) → Holding Register;  
 TBLPTR – No Change;  
 if TBLWT\*+,  
 (TABLAT) → Holding Register;  
 (TBLPTR) + 1 → TBLPTR;  
 if TBLWT\*-,  
 (TABLAT) → Holding Register;  
 (TBLPTR) – 1 → TBLPTR;  
 if TBLWT\*+\*,  
 (TBLPTR) + 1 → TBLPTR;  
 (TABLAT) → Holding Register;

Status Affected: None

Encoding:

0000	0000	0000	11nn nn=0 * =1 *+ =2 *- =3 +*
------	------	------	---

Description: This instruction uses the 3 LSBs of TBLPTR to determine which of the 8 holding registers the TABLAT is written to. The holding registers are used to program the contents of Program Memory (P.M.). (Refer to [Section 4.0 “Flash Program Memory”](#) for additional details on programming Flash memory.) The TBLPTR (a 21-bit pointer) points to each byte in the program memory. TBLPTR has a 2-MByte address range. The LSB of the TBLPTR selects which byte of the program memory location to access.

TBLPTR[0] = 0: Least Significant Byte of Program Memory Word

TBLPTR[0] = 1: Most Significant Byte of Program Memory Word

The TBLWT instruction can modify the value of TBLPTR as follows:

- no change
- post-increment
- post-decrement
- pre-increment

Words:      1

Cycles:     2

Q Cycle Activity:

	Q1	Q2	Q3	Q4
Decode	No operation	No operation	No operation	No operation
No operation	No operation (Read TABLAT)	No operation	No operation	No operation (Write to Holding Register)

**TBLWT**      **Table Write (Continued)**

---

Example 1:      TBLWT \*+;

Before Instruction

TABLAT	=	55h
TBLPTR	=	00A356h
HOLDING REGISTER (00A356h)	=	FFh

After Instructions (table write completion)

TABLAT	=	55h
TBLPTR	=	00A357h
HOLDING REGISTER (00A356h)	=	55h

Example 2:      TBLWT +\*;

Before Instruction

TABLAT	=	34h
TBLPTR	=	01389Ah
HOLDING REGISTER (01389Ah)	=	FFh
HOLDING REGISTER (01389Bh)	=	FFh

After Instruction (table write completion)

TABLAT	=	34h
TBLPTR	=	01389Bh
HOLDING REGISTER (01389Ah)	=	FFh
HOLDING REGISTER (01389Bh)	=	34h



**TSTFSZ**      **Test f, skip if 0**

Syntax:      TSTFSZ f {,a}

Operands:     $0 \leq f \leq 255$   
 $a \in [0,1]$

Operation:    skip if  $f = 0$

Status Affected:    None

Encoding:    

0110	011a	ffff	ffff
------	------	------	------

Description:    If 'f' = 0, the next instruction fetched during the current instruction execution is discarded and a NOP is executed, making this a two-cycle instruction. If 'a' is '0', the Access Bank is selected. If 'a' is '1', the BSR is used to select the GPR bank (default). If 'a' is '0' and the extended instruction set is enabled, this instruction operates in Indexed Literal Offset Addressing mode whenever  $f \leq 95$  (5Fh). See [Section 23.2.3 "Byte-Oriented and Bit-Oriented Instructions in Indexed Literal Offset Mode"](#) for details.

Words:      1

Cycles:      1(2)  
**Note:** 3 cycles if skip and followed by a 2-word instruction.

Q Cycle Activity:

Q1	Q2	Q3	Q4
Decode	Read register 'f'	Process Data	No operation

If skip:

Q1	Q2	Q3	Q4
No operation	No operation	No operation	No operation

If skip and followed by 2-word instruction:

Q1	Q2	Q3	Q4
No operation	No operation	No operation	No operation
No operation	No operation	No operation	No operation

**Example:**

```

HERE      TSTFSZ   CNT, 1
NZERO    :
ZERO     :
```

Before Instruction  
PC = Address (HERE)

After Instruction  
If CNT = 00h,  
PC = Address (ZERO)  
If CNT  $\neq$  00h,  
PC = Address (NZERO)

**XORLW**      **Exclusive OR literal with W**

Syntax:      XORLW k

Operands:     $0 \leq k \leq 255$

Operation:    (W) .XOR. k  $\rightarrow$  W

Status Affected:    N, Z

Encoding:    

0000	1010	kkkk	kkkk
------	------	------	------

Description:    The contents of W are XORed with the 8-bit literal 'k'. The result is placed in W.

Words:      1

Cycles:      1

Q Cycle Activity:

Q1	Q2	Q3	Q4
Decode	Read literal 'k'	Process Data	Write to W

**Example:**      XORLW    0AFh

Before Instruction  
W = B5h

After Instruction  
W = 1Ah

# PIC18(L)F1XK22

---

## XORWF Exclusive OR W with f

---

Syntax: XORWF f {,d {,a}}

Operands:  $0 \leq f \leq 255$   
 $d \in [0,1]$   
 $a \in [0,1]$

Operation: (W) .XOR. (f) → dest

Status Affected: N, Z

Encoding: 

0001	10da	ffff	ffff
------	------	------	------

Description: Exclusive OR the contents of W with register 'f'. If 'd' is '0', the result is stored in W. If 'd' is '1', the result is stored back in the register 'f' (default).  
If 'a' is '0', the Access Bank is selected. If 'a' is '1', the BSR is used to select the GPR bank (default).  
If 'a' is '0' and the extended instruction set is enabled, this instruction operates in Indexed Literal Offset Addressing mode whenever  $f \leq 95$  (5Fh). See [Section 23.2.3 "Byte-Oriented and Bit-Oriented Instructions in Indexed Literal Offset Mode"](#) for details.

Words: 1

Cycles: 1

Q Cycle Activity:

Q1	Q2	Q3	Q4
Decode	Read register 'f'	Process Data	Write to destination

**Example:** XORWF REG, 1, 0

Before Instruction

REG = AFh

W = B5h

After Instruction

REG = 1Ah

W = B5h

## 23.2 Extended Instruction Set

In addition to the standard 75 instructions of the PIC18 instruction set, PIC18(L)F1XK22 devices also provide an optional extension to the core CPU functionality. The added features include eight additional instructions that augment indirect and indexed addressing operations and the implementation of Indexed Literal Offset Addressing mode for many of the standard PIC18 instructions.

The additional features of the extended instruction set are disabled by default. To enable them, users must set the XINST Configuration bit.

The instructions in the extended set can all be classified as literal operations, which either manipulate the File Select Registers, or use them for indexed addressing. Two of the instructions, ADDFSR and SUBFSR, each have an additional special instantiation for using FSR2. These versions (ADDULNK and SUBULNK) allow for automatic return after execution.

The extended instructions are specifically implemented to optimize re-entrant program code (that is, code that is recursive or that uses a software stack) written in high-level languages, particularly C. Among other things, they allow users working in high-level languages to perform certain operations on data structures more efficiently. These include:

- dynamic allocation and deallocation of software stack space when entering and leaving subroutines
- function pointer invocation
- software Stack Pointer manipulation
- manipulation of variables located in a software stack

A summary of the instructions in the extended instruction set is provided in Table 23-3. Detailed descriptions are provided in Section 23.2.2 “Extended Instruction Set”. The opcode field descriptions in Table 23-1 (page 274) apply to both the standard and extended PIC18 instruction sets.

**Note:** The instruction set extension and the Indexed Literal Offset Addressing mode were designed for optimizing applications written in C; the user may likely never use these instructions directly in assembler. The syntax for these commands is provided as a reference for users who may be reviewing code that has been generated by a compiler.

### 23.2.1 EXTENDED INSTRUCTION SYNTAX

Most of the extended instructions use indexed arguments, using one of the File Select Registers and some offset to specify a source or destination register. When an argument for an instruction serves as part of indexed addressing, it is enclosed in square brackets (“[]”). This is done to indicate that the argument is used as an index or offset. MPASM™ Assembler will flag an error if it determines that an index or offset value is not bracketed.

When the extended instruction set is enabled, brackets are also used to indicate index arguments in byte-oriented and bit-oriented instructions. This is in addition to other changes in their syntax. For more details, see Section 23.2.3.1 “Extended Instruction Syntax with Standard PIC18 Commands”.

**Note:** In the past, square brackets have been used to denote optional arguments in the PIC18 and earlier instruction sets. In this text and going forward, optional arguments are denoted by braces (“{ }”).

**TABLE 23-3: EXTENSIONS TO THE PIC18 INSTRUCTION SET**

Mnemonic, Operands	Description	Cycles	16-Bit Instruction Word				Status Affected
			MSb		LSb		
ADDFSR f, k	Add literal to FSR	1	1110	1000	ffkk	kkkk	None
ADDULNK k	Add literal to FSR2 and return	2	1110	1000	11kk	kkkk	None
CALLW	Call subroutine using WREG	2	0000	0000	0001	0100	None
MOVSF z <sub>s</sub> , f <sub>d</sub>	Move z <sub>s</sub> (source) to 1st word f <sub>d</sub> (destination) 2nd word	2	1110	1011	0zzz	zzzz	None
MOVSS z <sub>s</sub> , z <sub>d</sub>	Move z <sub>s</sub> (source) to 1st word z <sub>d</sub> (destination) 2nd word	2	1110	1011	1zzz	zzzz	None
PUSHL k	Store literal at FSR2, decrement FSR2	1	1110	1010	kkkk	kkkk	None
SUBFSR f, k	Subtract literal from FSR	1	1110	1001	ffkk	kkkk	None
SUBULNK k	Subtract literal from FSR2 and return	2	1110	1001	11kk	kkkk	None

# PIC18(L)F1XK22

## 23.2.2 EXTENDED INSTRUCTION SET

### **ADDFSR**      **Add Literal to FSR**

Syntax:            ADDFSR f, k  
 Operands:         $0 \leq k \leq 63$   
                      $f \in [0, 1, 2]$   
 Operation:         $FSR(f) + k \rightarrow FSR(f)$   
 Status Affected:    None  
 Encoding:        

1110	1000	ffkk	kkkk
------	------	------	------

  
 Description:      The 6-bit literal 'k' is added to the contents of the FSR specified by 'f'.  
 Words:            1  
 Cycles:           1  
 Q Cycle Activity:

Q1	Q2	Q3	Q4
Decode	Read literal 'k'	Process Data	Write to FSR

**Example:**            ADDFSR 2, 23h

Before Instruction  
     FSR2    =    03FFh  
 After Instruction  
     FSR2    =    0422h

### **ADDULNK**      **Add Literal to FSR2 and Return**

Syntax:            ADDULNK k  
 Operands:         $0 \leq k \leq 63$   
 Operation:         $FSR2 + k \rightarrow FSR2,$   
                      $(TOS) \rightarrow PC$   
 Status Affected:    None  
 Encoding:        

1110	1000	11kk	kkkk
------	------	------	------

  
 Description:      The 6-bit literal 'k' is added to the contents of FSR2. A RETURN is then executed by loading the PC with the TOS. The instruction takes two cycles to execute; a NOP is performed during the second cycle. This may be thought of as a special case of the ADDFSR instruction, where  $f = 3$  (binary '11'); it operates only on FSR2.  
 Words:            1  
 Cycles:           2

Q Cycle Activity:

Q1	Q2	Q3	Q4
Decode	Read literal 'k'	Process Data	Write to FSR
No Operation	No Operation	No Operation	No Operation

**Example:**            ADDULNK 23h

Before Instruction  
     FSR2    =    03FFh  
     PC       =    0100h  
 After Instruction  
     FSR2    =    0422h  
     PC       =    (TOS)

**Note:** All PIC18 instructions may take an optional label argument preceding the instruction mnemonic for use in symbolic addressing. If a label is used, the instruction syntax then becomes: {label} instruction argument(s).

# PIC18(L)F1XK22

**CALLW Subroutine Call Using WREG**

Syntax: CALLW

Operands: None

Operation: (PC + 2) → TOS,  
(W) → PCL,  
(PCLATH) → PCH,  
(PCLATU) → PCU

Status Affected: None

Encoding: 

0000	0000	0001	0100
------	------	------	------

Description: First, the return address (PC + 2) is pushed onto the return stack. Next, the contents of W are written to PCL; the existing value is discarded. Then, the contents of PCLATH and PCLATU are latched into PCH and PCU, respectively. The second cycle is executed as a NOP instruction while the new next instruction is fetched. Unlike CALL, there is no option to update W, Status or BSR.

Words: 1

Cycles: 2

Q Cycle Activity:

Q1	Q2	Q3	Q4
Decode	Read WREG	PUSH PC to stack	No operation
No operation	No operation	No operation	No operation

**Example:**                    HERE        CALLW

Before Instruction

PC        =    address (HERE)

PCLATH =   10h

PCLATU =   00h

W         =   06h

After Instruction

PC        =   001006h

TOS       =   address (HERE + 2)

PCLATH =   10h

PCLATU =   00h

W         =   06h

**MOVSF Move Indexed to f**

Syntax: MOVSF [z<sub>s</sub>], f<sub>d</sub>

Operands: 0 ≤ z<sub>s</sub> ≤ 127  
0 ≤ f<sub>d</sub> ≤ 4095

Operation: ((FSR2) + z<sub>s</sub>) → f<sub>d</sub>

Status Affected: None

Encoding: 

1110	1011	0zzz	zzzz <sub>s</sub>
1111	ffff	ffff	ffff <sub>d</sub>

Description: The contents of the source register are moved to destination register 'f<sub>d</sub>'. The actual address of the source register is determined by adding the 7-bit literal offset 'z<sub>s</sub>' in the first word to the value of FSR2. The address of the destination register is specified by the 12-bit literal 'f<sub>d</sub>' in the second word. Both addresses can be anywhere in the 4096-byte data space (000h to FFFh). The MOVSF instruction cannot use the PCL, TOSU, TOSH or TOSL as the destination register. If the resultant source address points to an indirect addressing register, the value returned will be 00h.

Words: 2

Cycles: 2

Q Cycle Activity:

Q1	Q2	Q3	Q4
Decode	Determine source addr	Determine source addr	Read source reg
Decode	No operation No dummy read	No operation	Write register 'f' (dest)

**Example:**                    MOVSF [05h], REG2

Before Instruction

FSR2       =   80h

Contents of 85h = 33h

REG2       =  11h

After Instruction

FSR2       =   80h

Contents of 85h = 33h

REG2       =  33h

# PIC18(L)F1XK22

## MOVSS Move Indexed to Indexed

**Syntax:** MOVSS [z<sub>s</sub>], [z<sub>d</sub>]

**Operands:** 0 ≤ z<sub>s</sub> ≤ 127  
0 ≤ z<sub>d</sub> ≤ 127

**Operation:** ((FSR2) + z<sub>s</sub>) → ((FSR2) + z<sub>d</sub>)

**Status Affected:** None

**Encoding:**

1110	1011	1zzz	zzzz <sub>s</sub>
1111	xxxx	xzzz	zzzz <sub>d</sub>

**1st word (source)**  
**2nd word (dest.)**

**Description**

The contents of the source register are moved to the destination register. The addresses of the source and destination registers are determined by adding the 7-bit literal offsets 'z<sub>s</sub>' or 'z<sub>d</sub>', respectively, to the value of FSR2. Both registers can be located anywhere in the 4096-byte data memory space (000h to FFFh).

The MOVSS instruction cannot use the PCL, TOSU, TOSH or TOSL as the destination register.

If the resultant source address points to an indirect addressing register, the value returned will be 00h. If the resultant destination address points to an indirect addressing register, the instruction will execute as a NOP.

**Words:** 2  
**Cycles:** 2

**Q Cycle Activity:**

Q1	Q2	Q3	Q4
Decode	Determine source addr	Determine source addr	Read source reg
Decode	Determine dest addr	Determine dest addr	Write to dest reg

**Example:** MOVSS [05h], [06h]

**Before Instruction**

FSR2 = 80h  
 Contents of 85h = 33h  
 Contents of 86h = 11h

**After Instruction**

FSR2 = 80h  
 Contents of 85h = 33h  
 Contents of 86h = 33h

## PUSHL Store Literal at FSR2, Decrement FSR2

**Syntax:** PUSHL k

**Operands:** 0 ≤ k ≤ 255

**Operation:** k → (FSR2),  
FSR2 – 1 → FSR2

**Status Affected:** None

**Encoding:**

1110	1010	kkkk	kkkk
------	------	------	------

**Description:** The 8-bit literal 'k' is written to the data memory address specified by FSR2. FSR2 is decremented by 1 after the operation. This instruction allows users to push values onto a software stack.

**Words:** 1  
**Cycles:** 1

**Q Cycle Activity:**

Q1	Q2	Q3	Q4
Decode	Read 'k'	Process data	Write to destination

**Example:** PUSHL 08h

**Before Instruction**

FSR2H:FSR2L = 01ECh  
 Memory (01ECh) = 00h

**After Instruction**

FSR2H:FSR2L = 01EBh  
 Memory (01ECh) = 08h

# PIC18(L)F1XK22

## SUBFSR Subtract Literal from FSR

Syntax: SUBFSR f, k

Operands:  $0 \leq k \leq 63$   
 $f \in [0, 1, 2]$

Operation:  $FSR(f) - k \rightarrow FSRf$

Status Affected: None

Encoding: 

1110	1001	ffkk	kkkk
------	------	------	------

Description: The 6-bit literal 'k' is subtracted from the contents of the FSR specified by 'f'.

Words: 1

Cycles: 1

Q Cycle Activity:

Q1	Q2	Q3	Q4
Decode	Read register 'f'	Process Data	Write to destination

**Example:** SUBFSR 2, 23h

Before Instruction

FSR2 = 03FFh

After Instruction

FSR2 = 03DCh

## SUBULNK Subtract Literal from FSR2 and Return

Syntax: SUBULNK k

Operands:  $0 \leq k \leq 63$

Operation:  $FSR2 - k \rightarrow FSR2$   
 $(TOS) \rightarrow PC$

Status Affected: None

Encoding: 

1110	1001	1kkk	kkkk
------	------	------	------

Description: The 6-bit literal 'k' is subtracted from the contents of the FSR2. A RETURN is then executed by loading the PC with the TOS. The instruction takes two cycles to execute; a NOP is performed during the second cycle.

This may be thought of as a special case of the SUBFSR instruction, where  $f = 3$  (binary '11'); it operates only on FSR2.

Words: 1

Cycles: 2

Q Cycle Activity:

Q1	Q2	Q3	Q4
Decode	Read register 'f'	Process Data	Write to destination
No Operation	No Operation	No Operation	No Operation

**Example:** SUBULNK 23h

Before Instruction

FSR2 = 03FFh

PC = 0100h

After Instruction

FSR2 = 03DCh

PC = (TOS)

# PIC18(L)F1XK22

---

## 23.2.3 BYTE-ORIENTED AND BIT-ORIENTED INSTRUCTIONS IN INDEXED LITERAL OFFSET MODE

**Note:** Enabling the PIC18 instruction set extension may cause legacy applications to behave erratically or fail entirely.

In addition to eight new commands in the extended set, enabling the extended instruction set also enables Indexed Literal Offset Addressing mode ([Section 3.5.1 “Indexed Addressing with Literal Offset”](#)). This has a significant impact on the way that many commands of the standard PIC18 instruction set are interpreted.

When the extended set is disabled, addresses embedded in opcodes are treated as literal memory locations: either as a location in the Access Bank ( $'a' = 0$ ), or in a GPR bank designated by the BSR ( $'a' = 1$ ). When the extended instruction set is enabled and  $'a' = 0$ , however, a file register argument of 5Fh or less is interpreted as an offset from the pointer value in FSR2 and not as a literal address. For practical purposes, this means that all instructions that use the Access RAM bit as an argument – that is, all byte-oriented and bit-oriented instructions, or almost half of the core PIC18 instructions – may behave differently when the extended instruction set is enabled.

When the content of FSR2 is 00h, the boundaries of the Access RAM are essentially remapped to their original values. This may be useful in creating backward compatible code. If this technique is used, it may be necessary to save the value of FSR2 and restore it when moving back and forth between C and assembly routines in order to preserve the Stack Pointer. Users must also keep in mind the syntax requirements of the extended instruction set (see [Section 23.2.3.1 “Extended Instruction Syntax with Standard PIC18 Commands”](#)).

Although the Indexed Literal Offset Addressing mode can be very useful for dynamic stack and pointer manipulation, it can also be very annoying if a simple arithmetic operation is carried out on the wrong register. Users who are accustomed to the PIC18 programming must keep in mind that, when the extended instruction set is enabled, register addresses of 5Fh or less are used for Indexed Literal Offset Addressing.

Representative examples of typical byte-oriented and bit-oriented instructions in the Indexed Literal Offset Addressing mode are provided on the following page to show how execution is affected. The operand conditions shown in the examples are applicable to all instructions of these types.

### 23.2.3.1 Extended Instruction Syntax with Standard PIC18 Commands

When the extended instruction set is enabled, the file register argument, 'f', in the standard byte-oriented and bit-oriented commands is replaced with the literal offset value, 'k'. As already noted, this occurs only when 'f' is less than or equal to 5Fh. When an offset value is used, it must be indicated by square brackets (“[ ]”). As with the extended instructions, the use of brackets indicates to the compiler that the value is to be interpreted as an index or an offset. Omitting the brackets, or using a value greater than 5Fh within brackets, will generate an error in the MPASM™ assembler.

If the index argument is properly bracketed for Indexed Literal Offset Addressing, the Access RAM argument is never specified; it will automatically be assumed to be '0'. This is in contrast to standard operation (extended instruction set disabled) when 'a' is set on the basis of the target address. Declaring the Access RAM bit in this mode will also generate an error in the MPASM assembler.

The destination argument, 'd', functions as before.

In the latest versions of the MPASM assembler, language support for the extended instruction set must be explicitly invoked. This is done with either the command line option, /y, or the PE directive in the source listing.

## 23.2.4 CONSIDERATIONS WHEN ENABLING THE EXTENDED INSTRUCTION SET

It is important to note that the extensions to the instruction set may not be beneficial to all users. In particular, users who are not writing code that uses a software stack may not benefit from using the extensions to the instruction set.

Additionally, the Indexed Literal Offset Addressing mode may create issues with legacy applications written to the PIC18 assembler. This is because instructions in the legacy code may attempt to address registers in the Access Bank below 5Fh. Since these addresses are interpreted as literal offsets to FSR2 when the instruction set extension is enabled, the application may read or write to the wrong data addresses.

When porting an application to the PIC18(L)F1XK22, it is very important to consider the type of code. A large, re-entrant application that is written in 'C' and would benefit from efficient compilation will do well when using the instruction set extensions. Legacy applications that heavily use the Access Bank will most likely not benefit from using the extended instruction set.



# PIC18(L)F1XK22

## ADDWF ADD W to Indexed (Indexed Literal Offset mode)

**Syntax:** ADDWF [k] {,d}

**Operands:**  $0 \leq k \leq 95$   
 $d \in [0,1]$

**Operation:**  $(W) + ((FSR2) + k) \rightarrow \text{dest}$

**Status Affected:** N, OV, C, DC, Z

**Encoding:**

0010	01d0	kkkk	kkkk
------	------	------	------

**Description:** The contents of W are added to the contents of the register indicated by FSR2, offset by the value 'k'. If 'd' is '0', the result is stored in W. If 'd' is '1', the result is stored back in register 'f' (default).

**Words:** 1

**Cycles:** 1

**Q Cycle Activity:**

Q1	Q2	Q3	Q4
Decode	Read 'k'	Process Data	Write to destination

**Example:** ADDWF [OFST], 0

**Before Instruction**

W	=	17h
OFST	=	2Ch
FSR2	=	0A00h
Contents of 0A2Ch	=	20h

**After Instruction**

W	=	37h
Contents of 0A2Ch	=	20h

## BSF Bit Set Indexed (Indexed Literal Offset mode)

**Syntax:** BSF [k], b

**Operands:**  $0 \leq f \leq 95$   
 $0 \leq b \leq 7$

**Operation:**  $1 \rightarrow ((FSR2) + k) \langle b \rangle$

**Status Affected:** None

**Encoding:**

1000	bbb0	kkkk	kkkk
------	------	------	------

**Description:** Bit 'b' of the register indicated by FSR2, offset by the value 'k', is set.

**Words:** 1

**Cycles:** 1

**Q Cycle Activity:**

Q1	Q2	Q3	Q4
Decode	Read register 'f'	Process Data	Write to destination

**Example:** BSF [FLAG\_OFST], 7

**Before Instruction**

FLAG_OFST	=	0Ah
FSR2	=	0A00h
Contents of 0A0Ah	=	55h

**After Instruction**

Contents of 0A0Ah	=	D5h
-------------------	---	-----

## SETF Set Indexed (Indexed Literal Offset mode)

**Syntax:** SETF [k]

**Operands:**  $0 \leq k \leq 95$

**Operation:**  $FFh \rightarrow ((FSR2) + k)$

**Status Affected:** None

**Encoding:**

0110	1000	kkkk	kkkk
------	------	------	------

**Description:** The contents of the register indicated by FSR2, offset by 'k', are set to FFh.

**Words:** 1

**Cycles:** 1

**Q Cycle Activity:**

Q1	Q2	Q3	Q4
Decode	Read 'k'	Process Data	Write register

**Example:** SETF [OFST]

**Before Instruction**

OFST	=	2Ch
FSR2	=	0A00h
Contents of 0A2Ch	=	00h

**After Instruction**

Contents of 0A2Ch	=	FFh
-------------------	---	-----

# PIC18(L)F1XK22

---

## 23.2.5 SPECIAL CONSIDERATIONS WITH MICROCHIP MPLAB® IDE TOOLS

The latest versions of Microchip's software tools have been designed to fully support the extended instruction set of the PIC18(L)F1XK22 family of devices. This includes the MPLAB® C18 C compiler, MPASM assembly language and MPLAB Integrated Development Environment (IDE).

When selecting a target device for software development, MPLAB IDE will automatically set default Configuration bits for that device. The default setting for the XINST Configuration bit is '0', disabling the extended instruction set and Indexed Literal Offset Addressing mode. For proper execution of applications developed to take advantage of the extended instruction set, XINST must be set during programming.

To develop software for the extended instruction set, the user must enable support for the instructions and the Indexed Addressing mode in their language tool(s). Depending on the environment being used, this may be done in several ways:

- A menu option, or dialog box within the environment, that allows the user to configure the language tool and its settings for the project
- A command line option
- A directive in the source code

These options vary between different compilers, assemblers and development environments. Users are encouraged to review the documentation accompanying their development systems for the appropriate information.

## 24.0 DEVELOPMENT SUPPORT

The PIC® microcontrollers and dsPIC® digital signal controllers are supported with a full range of software and hardware development tools:

- Integrated Development Environment
  - MPLAB® IDE Software
- Compilers/Assemblers/Linkers
  - MPLAB C Compiler for Various Device Families
  - HI-TECH C® for Various Device Families
  - MPASM™ Assembler
  - MPLINK™ Object Linker/  
MPLIB™ Object Librarian
  - MPLAB Assembler/Linker/Librarian for Various Device Families
- Simulators
  - MPLAB SIM Software Simulator
- Emulators
  - MPLAB REAL ICE™ In-Circuit Emulator
- In-Circuit Debuggers
  - MPLAB ICD 3
  - PICKit™ 3 Debug Express
- Device Programmers
  - PICKit™ 2 Programmer
  - MPLAB PM3 Device Programmer
- Low-Cost Demonstration/Development Boards, Evaluation Kits, and Starter Kits

## 24.1 MPLAB Integrated Development Environment Software

The MPLAB IDE software brings an ease of software development previously unseen in the 8/16/32-bit microcontroller market. The MPLAB IDE is a Windows® operating system-based application that contains:

- A single graphical interface to all debugging tools
  - Simulator
  - Programmer (sold separately)
  - In-Circuit Emulator (sold separately)
  - In-Circuit Debugger (sold separately)
- A full-featured editor with color-coded context
- A multiple project manager
- Customizable data windows with direct edit of contents
- High-level source code debugging
- Mouse over variable inspection
- Drag and drop variables from source to watch windows
- Extensive on-line help
- Integration of select third party tools, such as IAR C Compilers

The MPLAB IDE allows you to:

- Edit your source files (either C or assembly)
- One-touch compile or assemble, and download to emulator and simulator tools (automatically updates all project information)
- Debug using:
  - Source files (C or assembly)
  - Mixed C and assembly
  - Machine code

MPLAB IDE supports multiple debugging tools in a single development paradigm, from the cost-effective simulators, through low-cost in-circuit debuggers, to full-featured emulators. This eliminates the learning curve when upgrading to tools with increased flexibility and power.

# PIC18(L)F1XK22

---

## 24.2 MPLAB C Compilers for Various Device Families

The MPLAB C Compiler code development systems are complete ANSI C compilers for Microchip's PIC18, PIC24 and PIC32 families of microcontrollers and the dsPIC30 and dsPIC33 families of digital signal controllers. These compilers provide powerful integration capabilities, superior code optimization and ease of use.

For easy source level debugging, the compilers provide symbol information that is optimized to the MPLAB IDE debugger.

## 24.3 HI-TECH C for Various Device Families

The HI-TECH C Compiler code development systems are complete ANSI C compilers for Microchip's PIC family of microcontrollers and the dsPIC family of digital signal controllers. These compilers provide powerful integration capabilities, omniscient code generation and ease of use.

For easy source level debugging, the compilers provide symbol information that is optimized to the MPLAB IDE debugger.

The compilers include a macro assembler, linker, pre-processor, and one-step driver, and can run on multiple platforms.

## 24.4 MPASM Assembler

The MPASM Assembler is a full-featured, universal macro assembler for PIC10/12/16/18 MCUs.

The MPASM Assembler generates relocatable object files for the MPLINK Object Linker, Intel® standard HEX files, MAP files to detail memory usage and symbol reference, absolute LST files that contain source lines and generated machine code and COFF files for debugging.

The MPASM Assembler features include:

- Integration into MPLAB IDE projects
- User-defined macros to streamline assembly code
- Conditional assembly for multi-purpose source files
- Directives that allow complete control over the assembly process

## 24.5 MPLINK Object Linker/ MPLIB Object Librarian

The MPLINK Object Linker combines relocatable objects created by the MPASM Assembler and the MPLAB C18 C Compiler. It can link relocatable objects from precompiled libraries, using directives from a linker script.

The MPLIB Object Librarian manages the creation and modification of library files of precompiled code. When a routine from a library is called from a source file, only the modules that contain that routine will be linked in with the application. This allows large libraries to be used efficiently in many different applications.

The object linker/library features include:

- Efficient linking of single libraries instead of many smaller files
- Enhanced code maintainability by grouping related modules together
- Flexible creation of libraries with easy module listing, replacement, deletion and extraction

## 24.6 MPLAB Assembler, Linker and Librarian for Various Device Families

MPLAB Assembler produces relocatable machine code from symbolic assembly language for PIC24, PIC32 and dsPIC devices. MPLAB C Compiler uses the assembler to produce its object file. The assembler generates relocatable object files that can then be archived or linked with other relocatable object files and archives to create an executable file. Notable features of the assembler include:

- Support for the entire device instruction set
- Support for fixed-point and floating-point data
- Command line interface
- Rich directive set
- Flexible macro language
- MPLAB IDE compatibility

## 24.7 MPLAB SIM Software Simulator

The MPLAB SIM Software Simulator allows code development in a PC-hosted environment by simulating the PIC MCUs and dsPIC<sup>®</sup> DSCs on an instruction level. On any given instruction, the data areas can be examined or modified and stimuli can be applied from a comprehensive stimulus controller. Registers can be logged to files for further run-time analysis. The trace buffer and logic analyzer display extend the power of the simulator to record and track program execution, actions on I/O, most peripherals and internal registers.

The MPLAB SIM Software Simulator fully supports symbolic debugging using the MPLAB C Compilers, and the MPASM and MPLAB Assemblers. The software simulator offers the flexibility to develop and debug code outside of the hardware laboratory environment, making it an excellent, economical software development tool.

## 24.8 MPLAB REAL ICE In-Circuit Emulator System

MPLAB REAL ICE In-Circuit Emulator System is Microchip's next generation high-speed emulator for Microchip Flash DSC and MCU devices. It debugs and programs PIC<sup>®</sup> Flash MCUs and dsPIC<sup>®</sup> Flash DSCs with the easy-to-use, powerful graphical user interface of the MPLAB Integrated Development Environment (IDE), included with each kit.

The emulator is connected to the design engineer's PC using a high-speed USB 2.0 interface and is connected to the target with either a connector compatible with in-circuit debugger systems (RJ11) or with the new high-speed, noise tolerant, Low-Voltage Differential Signal (LVDS) interconnection (CAT5).

The emulator is field upgradable through future firmware downloads in MPLAB IDE. In upcoming releases of MPLAB IDE, new devices will be supported, and new features will be added. MPLAB REAL ICE offers significant advantages over competitive emulators including low-cost, full-speed emulation, run-time variable watches, trace analysis, complex breakpoints, a ruggedized probe interface and long (up to three meters) interconnection cables.

## 24.9 MPLAB ICD 3 In-Circuit Debugger System

MPLAB ICD 3 In-Circuit Debugger System is Microchip's most cost effective high-speed hardware debugger/programmer for Microchip Flash Digital Signal Controller (DSC) and microcontroller (MCU) devices. It debugs and programs PIC<sup>®</sup> Flash microcontrollers and dsPIC<sup>®</sup> DSCs with the powerful, yet easy-to-use graphical user interface of MPLAB Integrated Development Environment (IDE).

The MPLAB ICD 3 In-Circuit Debugger probe is connected to the design engineer's PC using a high-speed USB 2.0 interface and is connected to the target with a connector compatible with the MPLAB ICD 2 or MPLAB REAL ICE systems (RJ-11). MPLAB ICD 3 supports all MPLAB ICD 2 headers.

## 24.10 PICkit 3 In-Circuit Debugger/Programmer and PICkit 3 Debug Express

The MPLAB PICkit 3 allows debugging and programming of PIC<sup>®</sup> and dsPIC<sup>®</sup> Flash microcontrollers at a most affordable price point using the powerful graphical user interface of the MPLAB Integrated Development Environment (IDE). The MPLAB PICkit 3 is connected to the design engineer's PC using a full speed USB interface and can be connected to the target via an Microchip debug (RJ-11) connector (compatible with MPLAB ICD 3 and MPLAB REAL ICE). The connector uses two device I/O pins and the reset line to implement in-circuit debugging and In-Circuit Serial Programming<sup>™</sup>.

The PICkit 3 Debug Express include the PICkit 3, demo board and microcontroller, hookup cables and CDROM with user's guide, lessons, tutorial, compiler and MPLAB IDE software.

# PIC18(L)F1XK22

---

## 24.11 PICkit 2 Development Programmer/Debugger and PICkit 2 Debug Express

The PICkit™ 2 Development Programmer/Debugger is a low-cost development tool with an easy to use interface for programming and debugging Microchip's Flash families of microcontrollers. The full featured Windows® programming interface supports baseline (PIC10F, PIC12F5xx, PIC16F5xx), midrange (PIC12F6xx, PIC16F), PIC18F, PIC24, dsPIC30, dsPIC33, and PIC32 families of 8-bit, 16-bit, and 32-bit microcontrollers, and many Microchip Serial EEPROM products. With Microchip's powerful MPLAB Integrated Development Environment (IDE) the PICkit™ 2 enables in-circuit debugging on most PIC® microcontrollers. In-Circuit-Debugging runs, halts and single steps the program while the PIC microcontroller is embedded in the application. When halted at a breakpoint, the file registers can be examined and modified.

The PICkit 2 Debug Express include the PICkit 2, demo board and microcontroller, hookup cables and CDROM with user's guide, lessons, tutorial, compiler and MPLAB IDE software.

## 24.12 MPLAB PM3 Device Programmer

The MPLAB PM3 Device Programmer is a universal, CE compliant device programmer with programmable voltage verification at VDDMIN and VDDMAX for maximum reliability. It features a large LCD display (128 x 64) for menus and error messages and a modular, detachable socket assembly to support various package types. The ICSP™ cable assembly is included as a standard item. In Stand-Alone mode, the MPLAB PM3 Device Programmer can read, verify and program PIC devices without a PC connection. It can also set code protection in this mode. The MPLAB PM3 connects to the host PC via an RS-232 or USB cable. The MPLAB PM3 has high-speed communications and optimized algorithms for quick programming of large memory devices and incorporates an MMC card for file storage and data applications.

## 24.13 Demonstration/Development Boards, Evaluation Kits, and Starter Kits

A wide variety of demonstration, development and evaluation boards for various PIC MCUs and dsPIC DSCs allows quick application development on fully functional systems. Most boards include prototyping areas for adding custom circuitry and provide application firmware and source code for examination and modification.

The boards support a variety of features, including LEDs, temperature sensors, switches, speakers, RS-232 interfaces, LCD displays, potentiometers and additional EEPROM memory.

The demonstration and development boards can be used in teaching environments, for prototyping custom circuits and for learning about various microcontroller applications.

In addition to the PICDEM™ and dsPICDEM™ demonstration/development board series of circuits, Microchip has a line of evaluation kits and demonstration software for analog filter design, KEELOQ® security ICs, CAN, IrDA®, PowerSmart battery management, SEEVAL® evaluation system, Sigma-Delta ADC, flow rate sensing, plus many more.

Also available are starter kits that contain everything needed to experience the specified device. This usually includes a single application and debug capability, all on one board.

Check the Microchip web page ([www.microchip.com](http://www.microchip.com)) for the complete list of demonstration, development and evaluation kits.

## 25.0 ELECTRICAL SPECIFICATIONS

### Absolute Maximum Ratings<sup>(†)</sup>

Ambient temperature under bias .....	-40°C to +125°C
Storage temperature .....	-65°C to +150°C
Voltage on VDD with respect to Vss, PIC18F1XK22 .....	-0.3V to +6.0V
Voltage on VDD with respect to Vss, PIC18LF1XK22 .....	-0.3V to +4.0V
Voltage on $\overline{\text{MCLR}}$ with respect to Vss .....	-0.3V to +11.0V
Voltage on all other pins with respect to Vss .....	-0.3V to (VDD + 0.3V)
Total power dissipation <sup>(1)</sup> .....	1.0 W
Maximum current out of Vss pin .....	300 mA
Maximum current into VDD pin .....	200 mA
Clamp current, I <sub>K</sub> (V <sub>PIN</sub> < 0 or V <sub>PIN</sub> > VDD).....	± 20 mA
Maximum output current sunk by any I/O pin.....	25 mA
Maximum output current sourced by any I/O pin .....	25 mA
Maximum current sunk by all ports .....	200 mA
Maximum current sourced by all ports .....	70 mA

**Note 1:** Power dissipation is calculated as follows:  $P_{DIS} = V_{DD} \times \{I_{DD} - \sum I_{OH}\} + \sum \{(V_{DD} - V_{OH}) \times I_{OH}\} + \sum (V_{OL} \times I_{OL})$ .

† NOTICE: Stresses above those listed under “Absolute Maximum Ratings” may cause permanent damage to the device. This is a stress rating only and functional operation of the device at those or any other conditions above those indicated in the operation listings of this specification is not implied. Exposure above maximum rating conditions for extended periods may affect device reliability.

# PIC18(L)F1XK22

FIGURE 25-1: PIC18F1XK22 VOLTAGE FREQUENCY GRAPH,  $-40^{\circ}\text{C} \leq T_A \leq +85^{\circ}\text{C}$

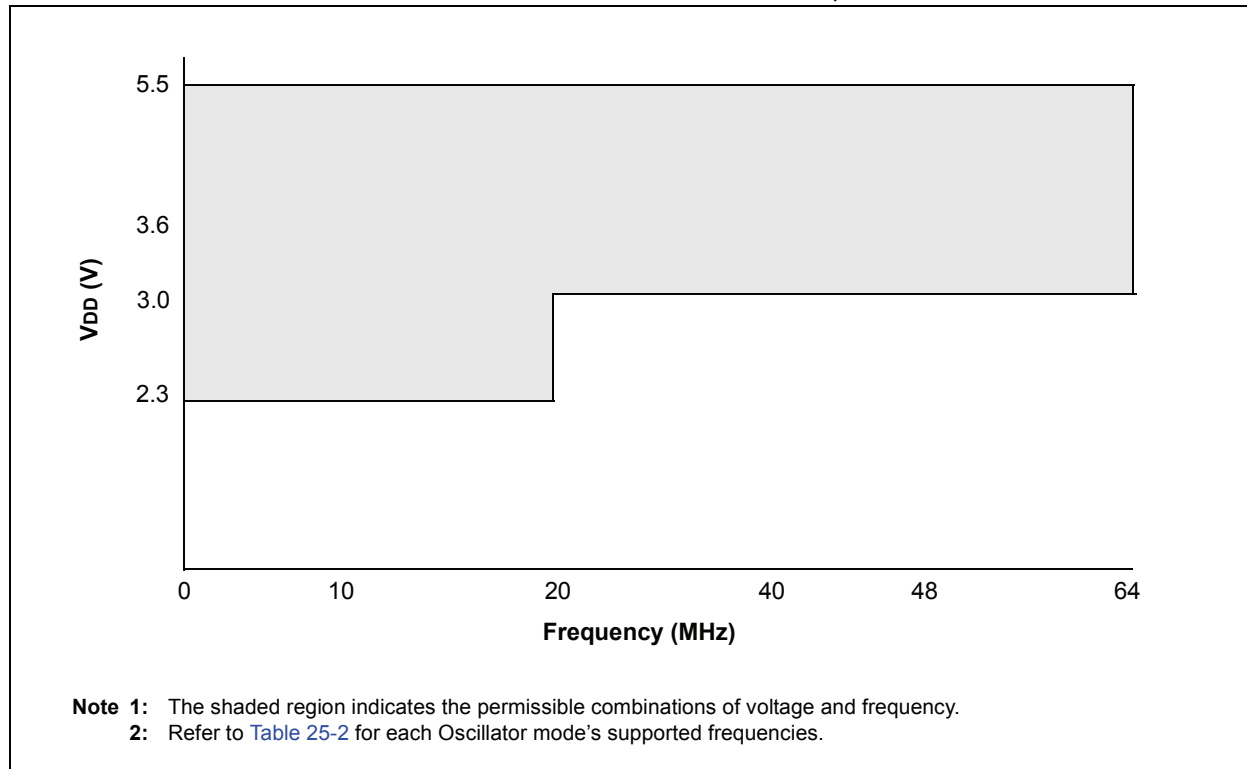
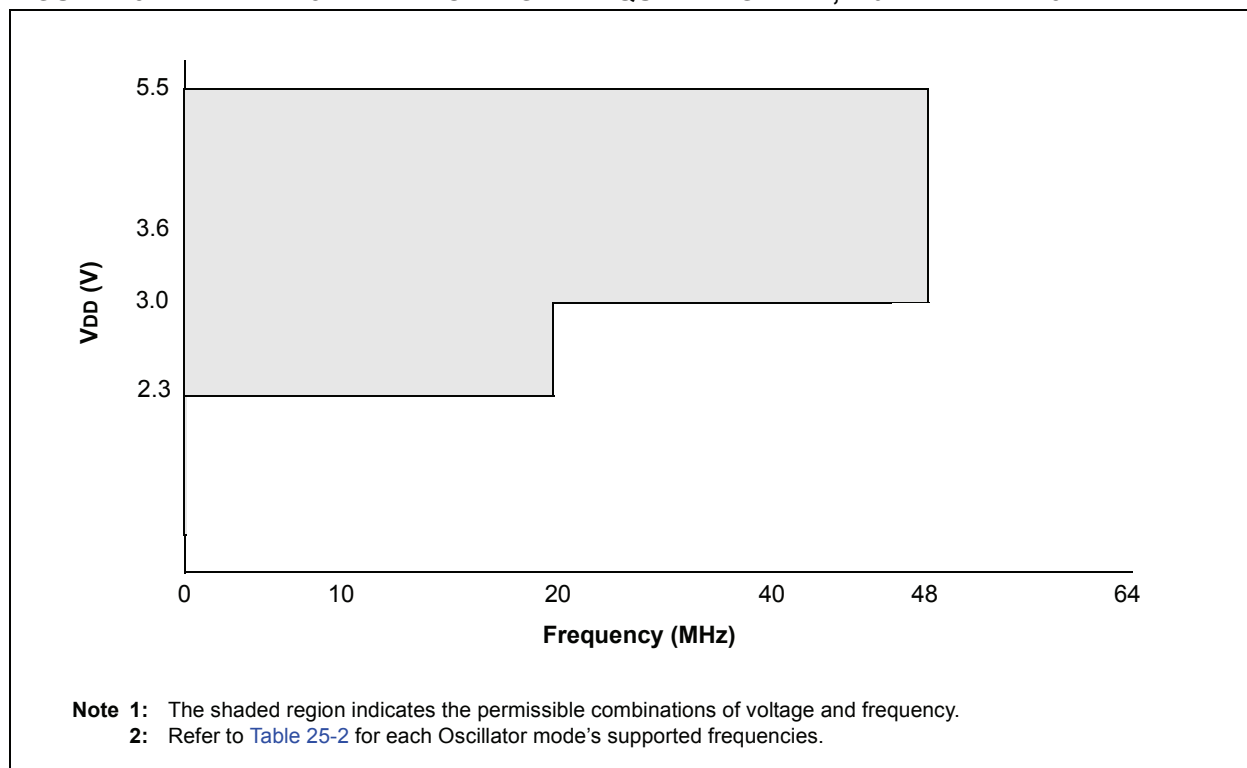
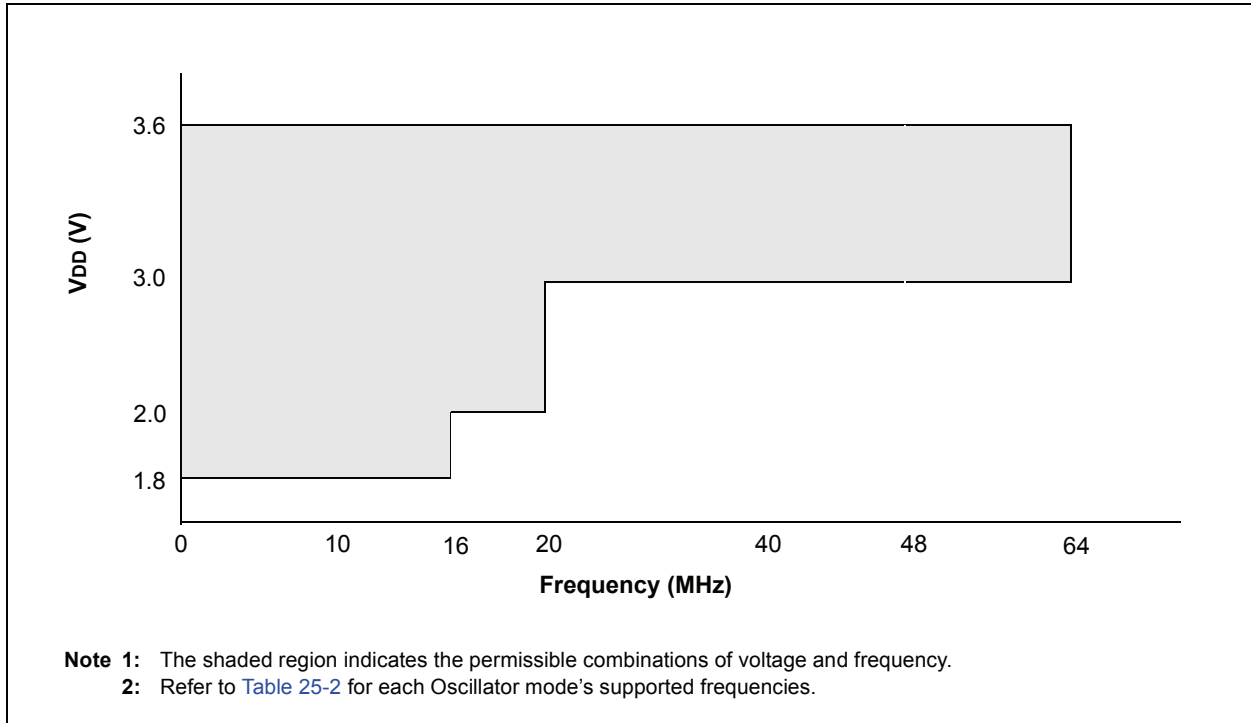


FIGURE 25-2: PIC18F1XK22 VOLTAGE FREQUENCY GRAPH,  $-40^{\circ}\text{C} \leq T_A \leq +125^{\circ}\text{C}$

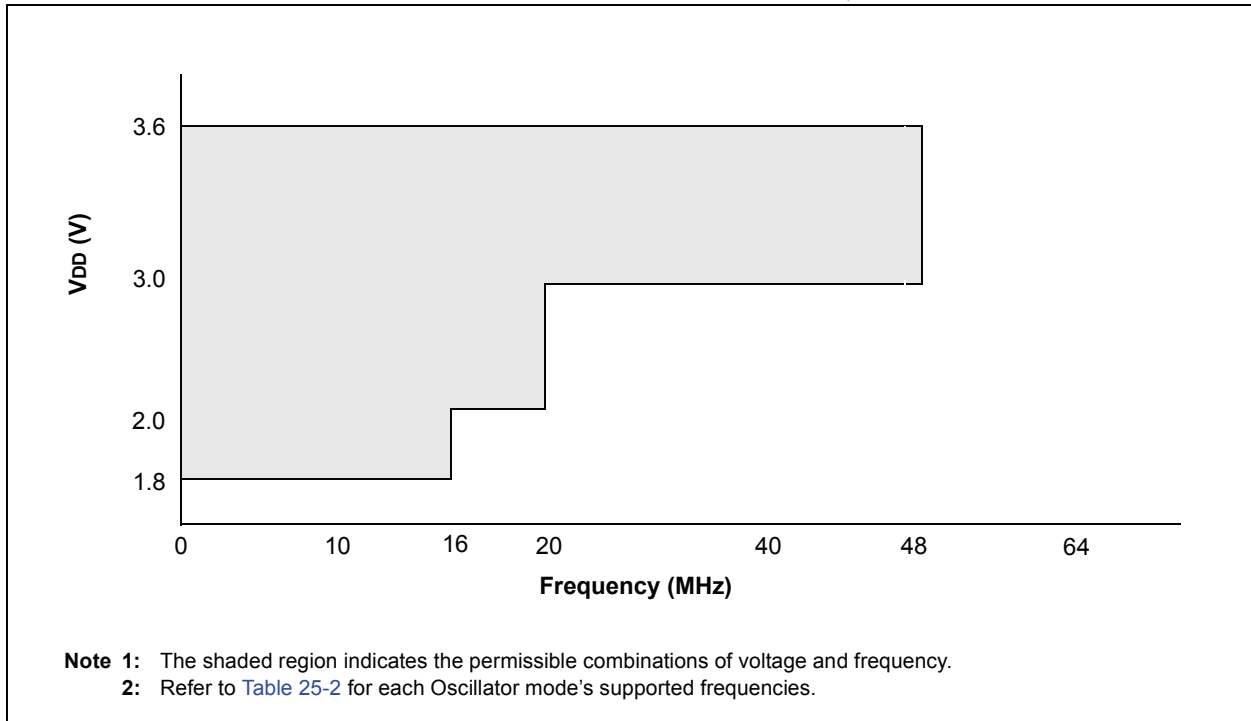




**FIGURE 25-3: PIC18LF1XK22 VOLTAGE FREQUENCY GRAPH,  $-40^{\circ}\text{C} \leq T_A \leq +85^{\circ}\text{C}$**

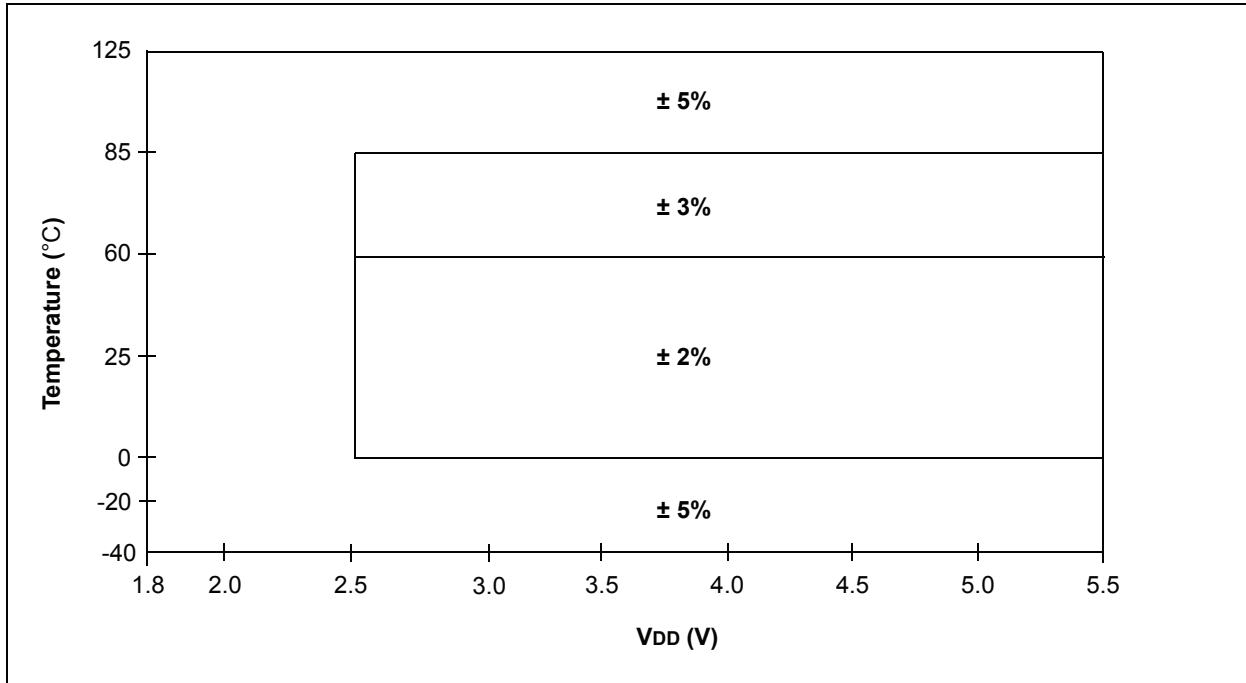


**FIGURE 25-4: PIC18LF1XK22 VOLTAGE FREQUENCY GRAPH,  $-40^{\circ}\text{C} \leq T_A \leq +125^{\circ}\text{C}$**



# PIC18(L)F1XK22

FIGURE 25-5: HFINTOSC FREQUENCY ACCURACY OVER DEVICE V<sub>DD</sub> AND TEMPERATURE



# PIC18(L)F1XK22

## 25.1 DC Characteristics: Supply Voltage, PIC18(L)F1XK22-I/E (Industrial, Extended)

PIC18LF1XK22		Standard Operating Conditions (unless otherwise stated) Operating temperature -40°C ≤ TA ≤ +85°C for industrial -40°C ≤ TA ≤ +125°C for extended					
PIC18F1XK22		Standard Operating Conditions (unless otherwise stated) Operating temperature -40°C ≤ TA ≤ +85°C for industrial -40°C ≤ TA ≤ +125°C for extended					
Param. No.	Sym.	Characteristic	Min.	Typ†	Max.	Units	Conditions
D001	VDD	<b>Supply Voltage</b>					
		PIC18LF1XK22	1.8	—	3.6	V	Fosc ≤ 16 MHz
			2.0	—	3.6	V	Fosc ≤ 20 MHz
			3.0	—	3.6	V	Fosc ≤ 64 MHz ≤ 85°C
3.0	—		3.6	V	Fosc ≤ 48 MHz ≤ 125°C		
D001		PIC18F1XK22	2.3	—	5.5	V	Fosc ≤ 20 MHz
			3.0	—	5.5	V	Fosc ≤ 64 MHz ≤ 85°C
			3.0	—	5.5	V	Fosc ≤ 48 MHz ≤ 125°C
D002*	VDR	<b>RAM Data Retention Voltage<sup>(1)</sup></b>					
		PIC18LF1XK22	1.5	—	—	V	Device in Sleep mode
D002*		PIC18F1XK22	1.7	—	—	V	Device in Sleep mode
	VPOR*	<b>Power-on Reset Release Voltage</b>	—	1.6	—	V	
	VPORR*	<b>Power-on Reset Rearm Voltage</b>	—	0.8	—	V	
D004*	SVDD	<b>VDD Rise Rate</b> to ensure internal Power-on Reset signal	0.05	—	—	V/ms	

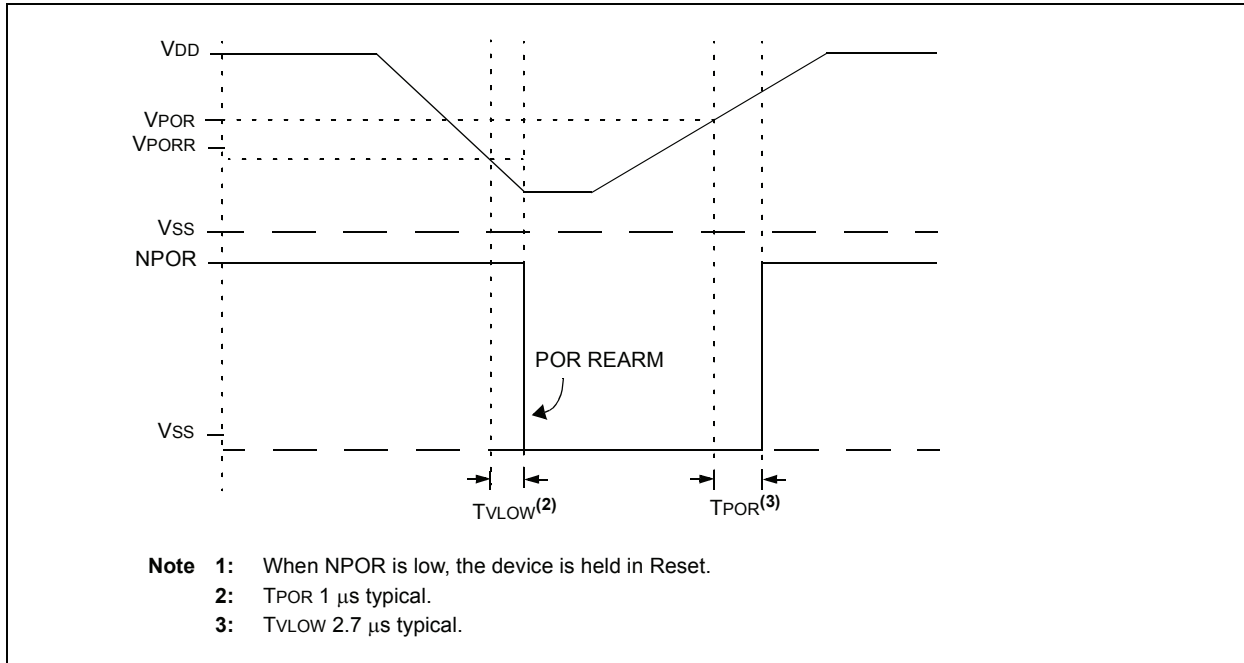
\* These parameters are characterized but not tested.

† Data in "Typ" column is at 3.0V, 25°C unless otherwise stated. These parameters are for design guidance only and are not tested.

**Note 1:** This is the limit to which VDD can be lowered in Sleep mode without losing RAM data.

# PIC18(L)F1XK22

FIGURE 25-6: POR AND POR REARM WITH SLOW RISING V<sub>DD</sub>



## 25.2 DC Characteristics: RC Run Supply Current, PIC18(L)F1XK22-I/E (Industrial, Extended)

PIC18LF1XK22		Standard Operating Conditions (unless otherwise stated)					
		Operating temperature -40°C ≤ TA ≤ +85°C for industrial -40°C ≤ TA ≤ +125°C for extended					
PIC18F1XK22		Standard Operating Conditions (unless otherwise stated)					
		Operating temperature -40°C ≤ TA ≤ +85°C for industrial -40°C ≤ TA ≤ +125°C for extended					
Param No.	Device Characteristics	Typ.	Max.	Units	Conditions		
D008	Supply Current (IDD) <sup>(1, 2, 4, 5)</sup>	6	9	μA	-40°C	VDD = 1.8V	Fosc = 31 kHz <sup>(4)</sup> (RC_RUN mode, LFINTOSC source)
		7	10	μA	+25°C		
		8	14	μA	+85°C		
		11	17	μA	+125°C		
D008A		11	15	μA	-40°C	VDD = 3.0V	
		12	16	μA	+25°C		
		13	25	μA	+85°C		
		17	28	μA	+125°C		
D008		22	45	μA	-40°C	VDD = 2.3V	
		23	48	μA	+25°C		
		25	50	μA	+85°C		
		28	55	μA	+125°C		
D008A		25	50	μA	-40°C	VDD = 3.0V	
		27	55	μA	+25°C		
		30	60	μA	+85°C		
		32	75	μA	+125°C		
D008B		30	55	μA	-40°C	VDD = 5.0V	
		33	60	μA	+25°C		
		37	65	μA	+85°C		
		40	80	μA	+125°C		
D009		0.4	0.5	mA	-40°C TO +125°C	VDD = 1.8V	Fosc = 1 MHz (RC_RUN mode, HFINTOSC source)
D009A		0.6	0.8	mA	-40°C TO +125°C	VDD = 3.0V	
D009		0.45	0.55	mA	-40°C TO +125°C	VDD = 2.3V	Fosc = 1 MHz (RC_RUN mode, HFINTOSC source)
D009A		0.60	0.82	mA	-40°C TO +125°C	VDD = 3.0V	
D009B		0.80	1.0	mA	-40°C TO +125°C	VDD = 5.0V	
D010		1.9	2.5	mA	-40°C TO +125°C	VDD = 1.8V	Fosc = 16 MHz (RC_RUN mode, HF-INTOSC source)
D010A		3.5	4.4	mA	-40°C TO +125°C	VDD = 3.0V	
D010		2.4	3.5	mA	-40°C TO +125°C	VDD = 2.3V	Fosc = 16 MHz (RC_RUN mode, HF-INTOSC source)
D010A		3.5	4.6	mA	-40°C TO +125°C	VDD = 3.0V	
D010B		3.7	4.7	mA	-40°C TO +125°C	VDD = 5.0V	

\* These parameters are characterized but not tested.

- Note 1:** The test conditions for all IDD measurements in active operation mode are: OSC1 = external square wave, from rail-to-rail; all I/O pins tri-stated, pulled to VDD; MCLR = VDD; WDT disabled.
- 2:** The supply current is mainly a function of the operating voltage and frequency. Other factors, such as I/O pin loading and switching rate, oscillator type, internal code execution pattern and temperature, also have an impact on the current consumption.
- 3:** For RC oscillator configurations, current through REXT is not included. The current through the resistor can be extended by the formula  $I_R = V_{DD}/2R_{EXT}$  (mA) with REXT in kΩ.
- 4:** FVR and BOR are disabled.
- 5:** When a single temperature range is provided for a parameter, the specification applies to both industrial and extended temperature devices.

# PIC18(L)F1XK22

## 25.3 DC Characteristics: RC Idle Supply Current, PIC18(L)F1XK22-I/E (Industrial, Extended)

PIC18LF1XK22		Standard Operating Conditions (unless otherwise stated)				
		Operating temperature -40°C ≤ TA ≤ +85°C for industrial -40°C ≤ TA ≤ +125°C for extended				
PIC18F1XK22		Standard Operating Conditions (unless otherwise stated)				
		Operating temperature -40°C ≤ TA ≤ +85°C for industrial -40°C ≤ TA ≤ +125°C for extended				
Param No.	Device Characteristics	Typ.	Max.	Units	Conditions	
D011	Supply Current (IDD) <sup>(1, 2, 4, 5)</sup>	2	5	μA	-40°C	VDD = 1.8V  Fosc = 31 kHz <sup>(4)</sup> (RC_IDLE mode, LFINTOSC source)
		2	6	μA	+25°C	
		3	9	μA	+85°C	
		8	11	μA	+125°C	
D011A		4	8	μA	-40°C	VDD = 3.0V  Fosc = 31 kHz <sup>(4)</sup> (RC_IDLE mode, LFINTOSC source)
		4	10	μA	+25°C	
		5	13	μA	+85°C	
		8	15	μA	+125°C	
D011		20	28	μA	-40°C	VDD = 2.3V  Fosc = 31 kHz <sup>(4)</sup> (RC_IDLE mode, LFINTOSC source)
		21	35	μA	+25°C	
		23	41	μA	+85°C	
		24	50	μA	+125°C	
D011A		23	35	μA	-40°C	VDD = 3.0V  Fosc = 31 kHz <sup>(4)</sup> (RC_IDLE mode, LFINTOSC source)
		25	40	μA	+25°C	
		28	46	μA	+85°C	
		30	65	μA	+125°C	
D011B		28	43	μA	-40°C	VDD = 5.0V  Fosc = 31 kHz <sup>(4)</sup> (RC_IDLE mode, LFINTOSC source)
		30	48	μA	+25°C	
		32	51	μA	+85°C	
		33	71	μA	+125°C	
D012		0.30	0.45	mA	-40°C to +125°C	VDD = 1.8V  Fosc = 1 MHz (RC_IDLE mode, HF-INTOSC source)
D012A		0.45	0.60	mA	-40°C to +125°C	VDD = 3.0V  Fosc = 1 MHz (RC_IDLE mode, HF-INTOSC source)
D012		0.32	0.45	mA	-40°C to +125°C	VDD = 2.3V  Fosc = 1 MHz (RC_IDLE mode, HF-INTOSC source)
D012A		0.47	0.62	mA	-40°C to +125°C	VDD = 3.0V  Fosc = 1 MHz (RC_IDLE mode, HF-INTOSC source)
D012B		0.63	0.78	mA	-40°C to +125°C	VDD = 5.0V  Fosc = 16 MHz (RC_IDLE mode, HF-INTOSC source)
D013		0.89	1.20	mA	-40°C to +125°C	VDD = 1.8V  Fosc = 16 MHz (RC_IDLE mode, HF-INTOSC source)
D013A		1.45	2.00	mA	-40°C to +125°C	VDD = 3.0V  Fosc = 16 MHz (RC_IDLE mode, HF-INTOSC source)
D013		1.10	1.50	mA	-40°C to +125°C	VDD = 2.3V  Fosc = 16 MHz (RC_IDLE mode, HF-INTOSC source)
D013A		1.45	2.00	mA	-40°C to +125°C	VDD = 3.0V  Fosc = 16 MHz (RC_IDLE mode, HF-INTOSC source)
D013B		1.53	2.20	mA	-40°C to +125°C	VDD = 5.0V  Fosc = 16 MHz (RC_IDLE mode, HF-INTOSC source)

\* These parameters are characterized but not tested.

- Note** 1: The test conditions for all IDD measurements in active operation mode are: OSC1 = external square wave, from rail-to-rail; all I/O pins tri-stated, pulled to VDD; MCLR = VDD; WDT disabled.
- 2: The supply current is mainly a function of the operating voltage and frequency. Other factors, such as I/O pin loading and switching rate, oscillator type, internal code execution pattern and temperature, also have an impact on the current consumption.
- 3: For RC oscillator configurations, current through REXT is not included. The current through the resistor can be extended by the formula  $I_R = V_{DD}/2R_{EXT}$  (mA) with REXT in kΩ.
- 4: FVR and BOR are disabled.
- 5: When a single temperature range is provided for a parameter, the specification applies to both industrial and extended temperature devices.

## 25.4 DC Characteristics: Primary Run Supply Current, PIC18(L)F1XK22-I/E (Industrial, Extended)

PIC18LF1XK22		Standard Operating Conditions (unless otherwise stated)					
		Operating temperature -40°C ≤ TA ≤ +85°C for industrial -40°C ≤ TA ≤ +125°C for extended					
PIC18F1XK22		Standard Operating Conditions (unless otherwise stated)					
		Operating temperature -40°C ≤ TA ≤ +85°C for industrial -40°C ≤ TA ≤ +125°C for extended					
Param No.	Device Characteristics	Typ.	Max.	Units	Conditions		
D014	Supply Current (IDD) <sup>(1, 2, 4, 5)</sup>	0.20	0.32	mA	-40°C to +125°C	VDD = 1.8V	Fosc = 1 MHz (PRI_RUN, EC Med Osc)
D014A		0.27	0.39	mA	-40°C to +125°C	VDD = 3.0V	
D014		.20	.32	mA	-40°C to +125°C	VDD = 2.3V	Fosc = 1 MHz (PRI_RUN, EC Med Osc)
D014A		.27	.39	mA	-40°C to +125°C	VDD = 3.0V	
D014B		.30	.42	mA	-40°C to +125°C	VDD = 5.0V	
D015		1.7	2.6	mA	-40°C to +125°C	VDD = 1.8V	Fosc = 16 MHz (PRI_RUN, EC High Osc)
D015A		3.0	4.2	mA	-40°C to +125°C	VDD = 3.0V	
D015		2.4	3.2	mA	-40°C to +125°C	VDD = 2.3V	Fosc = 16 MHz (PRI_RUN, EC High Osc)
D015A		3.0	4.2	mA	-40°C to +125°C	VDD = 3.0V	
D015B		3.3	4.4	mA	-40°C to +125°C	VDD = 5.0V	
D016		11.5	14.0	mA	-40°C to +125°C	VDD = 3.0V	Fosc = 64 MHz (PRI_RUN, EC High Osc)
D016		11.9	14.4	mA	-40°C to +125°C	VDD = 2.3V	
D016A		12.1	14.6	mA	-40°C to +125°C	VDD = 5.0V	Fosc = 64 MHz (PRI_RUN, EC High Osc)
D017		2.1	2.9	mA	-40°C to +125°C	VDD = 1.8V	Fosc = 4 MHz 16 MHz Internal (PRI_RUN HS+PLL)
D017A		3.1	4.0	mA	-40°C to +125°C	VDD = 3.0V	
D017		2.1	2.9	mA	-40°C to +125°C	VDD = 2.3V	Fosc = 4 MHz 16 MHz Internal (PRI_RUN HS+PLL)
D017A		3.1	4.0	mA	-40°C to +125°C	VDD = 3.0V	
D017B		3.3	4.5	mA	-40°C to +125°C	VDD = 5.0V	
D018		10	15	mA	-40°C to +125°C	VDD = 3.0V	Fosc = 16 MHz 64 MHz Internal (PRI_RUN HS+PLL)
D018		12.4	15.4	mA	-40°C to +125°C	VDD = 3.0V	
D018A		12.6	15.6	mA	-40°C to +125°C	VDD = 5.0V	Fosc = 16 MHz 64 MHz Internal (PRI_RUN HS+PLL)

\* These parameters are characterized but not tested.

- Note 1:** The test conditions for all IDD measurements in active operation mode are: OSC1 = external square wave, from rail-to-rail; all I/O pins tri-stated, pulled to VDD; MCLR = VDD; WDT disabled.
- 2:** The supply current is mainly a function of the operating voltage and frequency. Other factors, such as I/O pin loading and switching rate, oscillator type, internal code execution pattern and temperature, also have an impact on the current consumption.
- 3:** For RC oscillator configurations, current through REXT is not included. The current through the resistor can be extended by the formula  $I_R = V_{DD}/2R_{EXT}$  (mA) with REXT in kΩ.
- 4:** FVR and BOR are disabled.
- 5:** When a single temperature range is provided for a parameter, the specification applies to both industrial and extended temperature devices.

# PIC18(L)F1XK22

## 25.5 DC Characteristics: Primary Idle Supply Current, PIC18(L)F1XK22-I/E (Industrial, Extended)

PIC18LF1XK22		Standard Operating Conditions (unless otherwise stated)					
		Operating temperature $-40^{\circ}\text{C} \leq T_A \leq +85^{\circ}\text{C}$ for industrial $-40^{\circ}\text{C} \leq T_A \leq +125^{\circ}\text{C}$ for extended					
PIC18F1XK22		Standard Operating Conditions (unless otherwise stated)					
		Operating temperature $-40^{\circ}\text{C} \leq T_A \leq +85^{\circ}\text{C}$ for industrial $-40^{\circ}\text{C} \leq T_A \leq +125^{\circ}\text{C}$ for extended					
Param No.	Device Characteristics	Typ.	Max.	Units	Conditions		
D019	Supply Current (IDD) <sup>(1, 2, 4, 5)</sup>	70	105	$\mu\text{A}$	$-40^{\circ}\text{C}$ to $+125^{\circ}\text{C}$	VDD = 1.8V	Fosc = 1 MHz (PRI_IDLE mode, EC Med Osc)
D019A		140	180	$\mu\text{A}$	$-40^{\circ}\text{C}$ to $+125^{\circ}\text{C}$	VDD = 3.0V	
D019		80	120	$\mu\text{A}$	$-40^{\circ}\text{C}$ to $+125^{\circ}\text{C}$	VDD = 2.3V	Fosc = 1 MHz (PRI_IDLE mode, EC Med Osc)
D019A		140	180	$\mu\text{A}$	$-40^{\circ}\text{C}$ to $+125^{\circ}\text{C}$	VDD = 3.0V	
D019B		151	230	$\mu\text{A}$	$-40^{\circ}\text{C}$ to $+125^{\circ}\text{C}$	VDD = 5.0V	
D020		1.0	1.8	mA	$-40^{\circ}\text{C}$ to $+125^{\circ}\text{C}$	VDD = 1.8V	Fosc = 16 MHz (PRI_IDLE mode, EC High Osc)
D020A		1.2	2.0	mA	$-40^{\circ}\text{C}$ to $+125^{\circ}\text{C}$	VDD = 3.0V	
D020		1.0	1.8	mA	$-40^{\circ}\text{C}$ to $+125^{\circ}\text{C}$	VDD = 2.3V	Fosc = 16 MHz (PRI_IDLE mode, EC High Osc)
D020A		1.2	2.0	mA	$-40^{\circ}\text{C}$ to $+125^{\circ}\text{C}$	VDD = 3.0V	
D020B		1.4	2.1	mA	$-40^{\circ}\text{C}$ to $+125^{\circ}\text{C}$	VDD = 5.0V	
D021		5.0	7.0	mA	$-40^{\circ}\text{C}$ to $+125^{\circ}\text{C}$	VDD = 3.0V	Fosc = 64 MHz (PRI_IDLE mode, EC High Osc)
D021		5.2	6.2	mA	$-40^{\circ}\text{C}$ to $+125^{\circ}\text{C}$	VDD = 3.0V	Fosc = 64 MHz (PRI_IDLE mode, EC High Osc)
D021A		5.3	6.3	mA	$-40^{\circ}\text{C}$ to $+125^{\circ}\text{C}$	VDD = 5.0V	

\* These parameters are characterized but not tested.

- Note 1:** The test conditions for all IDD measurements in active operation mode are: OSC1 = external square wave, from rail-to-rail; all I/O pins tri-stated, pulled to VDD; MCLR = VDD; WDT disabled.
- 2:** The supply current is mainly a function of the operating voltage and frequency. Other factors, such as I/O pin loading and switching rate, oscillator type, internal code execution pattern and temperature, also have an impact on the current consumption.
- 3:** For RC oscillator configurations, current through REXT is not included. The current through the resistor can be extended by the formula  $I_R = V_{DD}/2R_{EXT}$  (mA) with REXT in k $\Omega$ .
- 4:** FVR and BOR are disabled.
- 5:** When a single temperature range is provided for a parameter, the specification applies to both industrial and extended temperature devices.



## 25.6 DC Characteristics: Secondary Run Supply Current, PIC18(L)F1XK22-I/E (Industrial, Extended)

PIC18LF1XK22		Standard Operating Conditions (unless otherwise stated)					
		Operating temperature -40°C ≤ TA ≤ +85°C for industrial -40°C ≤ TA ≤ +125°C for extended					
PIC18F1XK22		Standard Operating Conditions (unless otherwise stated)					
		Operating temperature -40°C ≤ TA ≤ +85°C for industrial -40°C ≤ TA ≤ +125°C for extended					
Param No.	Device Characteristics	Typ.	Max.	Units	Conditions		
D022	Supply Current (IDD) <sup>(1, 2, 4)</sup>	6	9	μA	-40°C	VDD = 1.8V	FOSC = 32 kHz <sup>(3)</sup> (SEC_RUN mode, Timer1 as clock)
		6	10	μA	+25°C		
		7	14	μA	+85°C		
		11	17	μA	+125°C		
D022A		11	15	μA	-40°C	VDD = 3.0V	
		11	16	μA	+25°C		
		12	25	μA	+85°C		
		26	28	μA	+125°C		
D022		22	65	μA	-40°C	VDD = 2.3V	
		23	67	μA	+25°C		
		25	69	μA	+85°C		
		28	75	μA	+125°C		
D022A		25	70	μA	-40°C	VDD = 3.0V	
		27	72	μA	+25°C		
		30	74	μA	+85°C		
		32	77	μA	+125°C		
D022B		30	75	μA	-40°C	VDD = 5.0V	
		32	77	μA	+25°C		
		34	79	μA	+85°C		
		35	83	μA	+125°C		

\* These parameters are characterized but not tested.

- Note 1:** The test conditions for all IDD measurements in active operation mode are: OSC1 = external square wave, from rail-to-rail; all I/O pins tri-stated, pulled to VDD; MCLR = VDD; WDT disabled.
- 2:** The supply current is mainly a function of the operating voltage and frequency. Other factors, such as I/O pin loading and switching rate, oscillator type, internal code execution pattern and temperature, also have an impact on the current consumption.
- 3:** For RC oscillator configurations, current through REXT is not included. The current through the resistor can be extended by the formula  $I_R = V_{DD}/2R_{EXT}$  (mA) with REXT in kΩ.
- 4:** FVR and BOR are disabled.

# PIC18(L)F1XK22

## 25.7 DC Characteristics: Secondary Idle Supply Current, PIC18(L)F1XK22-I/E (Industrial, Extended)

PIC18LF1XK22		Standard Operating Conditions (unless otherwise stated)				
		Operating temperature -40°C ≤ TA ≤ +85°C for industrial -40°C ≤ TA ≤ +125°C for extended				
PIC18F1XK22		Standard Operating Conditions (unless otherwise stated)				
		Operating temperature -40°C ≤ TA ≤ +85°C for industrial -40°C ≤ TA ≤ +125°C for extended				
Param No.	Device Characteristics	Typ.	Max.	Units	Conditions	
D023	Supply Current (IDD) <sup>(1, 2, 4)</sup>	2	5	μA	-40°C	VDD = 1.8V  FOSC = 32 kHz <sup>(3)</sup> (SEC_IDLE mode, Timer1 as clock)
		2	5	μA	+25°C	
		3	9	μA	+85°C	
		8	11	μA	+125°C	
D023A		4	8	μA	-40°C	VDD = 3.0V  FOSC = 32 kHz <sup>(3)</sup> (SEC_IDLE mode, Timer1 as clock)
		5	10	μA	+25°C	
		9	20	μA	+85°C	
		20	23	μA	+125°C	
D023		20	40	μA	-40°C	VDD = 2.3V  FOSC = 32 kHz <sup>(3)</sup> (SEC_IDLE mode, Timer1 as clock)
		21	41	μA	+25°C	
		23	44	μA	+85°C	
		24	47	μA	+125°C	
D023A		23	45	μA	-40°C	VDD = 3.0V  FOSC = 32 kHz <sup>(3)</sup> (SEC_IDLE mode, Timer1 as clock)
		25	47	μA	+25°C	
		28	49	μA	+85°C	
		30	52	μA	+125°C	
D023B		28	50	μA	-40°C	VDD = 5.0V  FOSC = 32 kHz <sup>(3)</sup> (SEC_IDLE mode, Timer1 as clock)
		30	54	μA	+25°C	
		32	59	μA	+85°C	
		33	62	μA	+125°C	

\* These parameters are characterized but not tested.

- Note 1:** The test conditions for all IDD measurements in active operation mode are: OSC1 = external square wave, from rail-to-rail; all I/O pins tri-stated, pulled to VDD; MCLR = VDD; WDT disabled.
- 2:** The supply current is mainly a function of the operating voltage and frequency. Other factors, such as I/O pin loading and switching rate, oscillator type, internal code execution pattern and temperature, also have an impact on the current consumption.
- 3:** For RC oscillator configurations, current through REXT is not included. The current through the resistor can be extended by the formula  $I_R = V_{DD}/2R_{EXT}$  (mA) with REXT in kΩ.
- 4:** FVR and BOR are disabled.

## 25.8 DC Characteristics: Power-Down Current, PIC18(L)F1XK22-I/E (Industrial, Extended)

PIC18LF1XK22		Standard Operating Conditions (unless otherwise stated)						
		Operating temperature -40°C ≤ TA ≤ +85°C for industrial -40°C ≤ TA ≤ +125°C for extended						
PIC18F1XK22		Standard Operating Conditions (unless otherwise stated)						
		Operating temperature -40°C ≤ TA ≤ +85°C for industrial -40°C ≤ TA ≤ +125°C for extended						
Param No.	Device Characteristics	Min.	Typ†	Max. +85°C	Max. +125°C	Units	Conditions	
							VDD	Note
<b>Power-down Base Current (IPD)<sup>(2)</sup></b>								
D027		—	0.034	1.0	9.0	μA	1.8	WDT, BOR, FVR, T1OSC disabled, all Peripherals Inactive
		—	0.071	2.0	10	μA	3.0	
D027		—	17	40	55	μA	2.3	WDT, BOR, FVR and T1OSC disabled, all Peripherals Inactive
		—	18	43	65	μA	3.0	
		—	20	45	80	μA	5.0	
<b>Power-down Module Current</b>								
D028		—	.46	1.3	10	μA	1.8	LPWDT Current <sup>(1)</sup>
		—	.74	3.0	11	μA	3.0	
D028		—	18	44	60	μA	2.3	LPWDT Current <sup>(1)</sup>
		—	21	46	70	μA	3.0	
		—	22	48	85	μA	5.0	
D029		—	12	20	28	μA	1.8	FVR Current <sup>(3)</sup>
		—	14	22	30	μA	3.0	
D029		—	40	65	80	μA	2.3	FVR Current <sup>(3)</sup>
		—	50	70	85	μA	3.0	
		—	70	120	135	μA	5.0	
D030		—	12	17	23	μA	3.0	BOR Current <sup>(1, 3)</sup>
D030		—	30	55	80	μA	3.0	BOR Current <sup>(1, 3)</sup>
		—	64	100	120	μA	5.0	
D031		—	.65	1.5	11	μA	1.8	T1OSC Current <sup>(1)</sup>
		—	0.90	4.0	12	μA	3.0	
D031		—	19	45	60	μA	2.3	T1OSC Current <sup>(1)</sup>
		—	20	50	70	μA	3.0	
		—	22	55	80	μA	5.0	

\* These parameters are characterized but not tested.

† Data in "Typ" column is at 3.0V, 25°C unless otherwise stated. These parameters are for design guidance only and are not tested.

- Note**
- 1: The peripheral current is the sum of the base IDD or IPD and the additional current consumed when this peripheral is enabled. The peripheral Δ current can be determined by subtracting the base IDD or IPD current from this limit. Max values should be used when calculating total current consumption.
  - 2: The power-down current in Sleep mode does not depend on the oscillator type. Power-down current is measured with the part in Sleep mode, with all I/O pins in high-impedance state and tied to VDD.
  - 3: Fixed Voltage Reference is automatically enabled whenever the BOR is enabled.
  - 4: A/D oscillator source is FRC.

# PIC18(L)F1XK22

## 25.8 DC Characteristics: Power-Down Current, PIC18(L)F1XK22-I/E (Industrial, Extended) (Continued)

PIC18LF1XK22			Standard Operating Conditions (unless otherwise stated) Operating temperature -40°C ≤ TA ≤ +85°C for industrial -40°C ≤ TA ≤ +125°C for extended					
PIC18F1XK22			Standard Operating Conditions (unless otherwise stated) Operating temperature -40°C ≤ TA ≤ +85°C for industrial -40°C ≤ TA ≤ +125°C for extended					
Param No.	Device Characteristics	Min.	Typ†	Max. +85°C	Max. +125°C	Units	Conditions	
							VDD	Note
<b>Power-down Module Current</b>								
D032		—	.7	1.0	9.0	μA	1.8	A/D Current <sup>(1,4)</sup> , no conversion in progress
		—	.8	3.0	10	μA	3.0	
D032		—	19	42	60	μA	2.3	A/D Current <sup>(1,4)</sup> , no conversion in progress
		—	20	44	65	μA	3.0	
		—	22	46	80	μA	5.0	
D033		—	8	30	32	μA	1.8	Comparator Current, low power C1 and C2 enabled
		—	11	32	35	μA	3.0	
D033		—	23	55	65	μA	2.3	Comparator Current, low power C1 and C2 enabled
		—	31	65	75	μA	3.0	
		—	33	75	95	μA	5.0	
D033A		—	44	110	160	μA	1.8	Comparator Current, high power C1 and C2 enabled
		—	65	130	165	μA	3.0	
D033A		—	77	137	155	μA	2.3	Comparator Current, high power C1 and C2 enabled
		—	84	140	165	μA	3.0	
		—	90	150	180	μA	5.0	
D034		—	13	18	33	μA	1.8	Voltage Reference Current
		—	22	30	40	μA	3.0	
D034		—	33	55	85	μA	2.3	Voltage Reference Current
		—	35	80	95	μA	3.0	
		—	48	90	120	μA	5.0	

\* These parameters are characterized but not tested.

† Data in "Typ" column is at 3.0V, 25°C unless otherwise stated. These parameters are for design guidance only and are not tested.

- Note 1:** The peripheral current is the sum of the base IDD or IPD and the additional current consumed when this peripheral is enabled. The peripheral Δ current can be determined by subtracting the base IDD or IPD current from this limit. Max values should be used when calculating total current consumption.
- Note 2:** The power-down current in Sleep mode does not depend on the oscillator type. Power-down current is measured with the part in Sleep mode, with all I/O pins in high-impedance state and tied to VDD.
- Note 3:** Fixed Voltage Reference is automatically enabled whenever the BOR is enabled.
- Note 4:** A/D oscillator source is FRC.

## 25.9 DC Characteristics: PIC18(L)F1XK22-I/E

DC CHARACTERISTICS		Standard Operating Conditions (unless otherwise stated) Operating temperature $-40^{\circ}\text{C} \leq T_A \leq +85^{\circ}\text{C}$ for industrial $-40^{\circ}\text{C} \leq T_A \leq +125^{\circ}\text{C}$ for extended						
Param No.	Sym.	Characteristic	Min.	Typ†	Max.	Units	Conditions	
D036 D036A D036B D037 D037A D037B D038 D039 D039A D039B D039C	VIL	<b>Input Low Voltage</b>						
		I/O ports:						
		with TTL buffer	VSS	—	0.8	V	$4.5\text{V} \leq V_{DD} \leq 5.5\text{V}$	
			VSS	—	0.15 VDD	V	$1.8\text{V} \leq V_{DD} \leq 4.5\text{V}$	
			VSS	—	0.2 VDD	V	$2.0\text{V} \leq V_{DD} \leq 5.5\text{V}$	
		with Schmitt Trigger buffer	VSS	—	0.2 VDD	V	$1.8\text{V} \leq V_{DD} \leq 5.5\text{V}$	
		with I <sup>2</sup> C™ levels	VSS	—	0.3 VDD	V		
		with SMBus levels	VSS	—	0.8 VDD	V	$2.7\text{V} \leq V_{DD} \leq 5.5\text{V}$	
		MCLR	VSS	—	0.2 VDD	V		
		OSC1	VSS	—	0.3 VDD	V	HS, HSPLL modes	
		OSC1	VSS	—	0.2 VDD	V	EC, RC modes <sup>(1)</sup>	
		OSC1	VSS	—	0.3 VDD	V	XT, LP modes	
T1CKI	VSS	—	0.3 VDD	V				
D040 D040A D041 D041A D037A D042 D042A D043 D043A D043B D043C D043E	VIH	<b>Input High Voltage</b>						
		I/O ports:						
		with TTL buffer	2.0	—	VDD	V	$4.5\text{V} \leq V_{DD} \leq 5.5\text{V}$	
			0.25 VDD + 0.8	—	VDD	V	$1.8\text{V} \leq V_{DD} \leq 4.5\text{V}$	
		with Schmitt Trigger buffer	0.8 VDD	—	VDD	V	$1.8\text{V} \leq V_{DD} \leq 5.5\text{V}$	
		with I <sup>2</sup> C levels	0.7 VDD	—	VDD	V		
		with SMBus levels	2.1	—	VDD	V	$2.7\text{V} \leq V_{DD} \leq 5.5\text{V}$	
		MCLR	0.8 VDD	—	VDD	V		
		MCLR	0.9 VDD	—	0.3 VDD	V	$1.8\text{V} \leq V_{DD} \leq 2.4\text{V}$	
		OSC1	0.7 VDD	—	VDD	V	HS, HSPLL modes	
		OSC1	0.8 VDD	—	VDD	V	EC mode	
		OSC1	0.9 VDD	—	VDD	V	RC mode <sup>(1)</sup>	
OSC1	1.6	—	VDD	V	XT, LP modes			
T1CKI	1.6	—	VDD	V				
D060 D061	IIL	<b>Input Leakage Current<sup>(2)</sup></b>						
		I/O ports	—	± 5	± 100	nA	$V_{SS} \leq V_{PIN} \leq V_{DD}$ , Pin at high-impedance, $-40^{\circ}\text{C}$ to $85^{\circ}\text{C}$	
			—	± 5	± 1000	nA	$V_{SS} \leq V_{PIN} \leq V_{DD}$ , $85^{\circ}\text{C}$ to $125^{\circ}\text{C}$	
D061		MCLR <sup>(3)</sup>	—	± 50	± 200	nA	$V_{SS} \leq V_{PIN} \leq V_{DD}$	
D070*	IPUR	<b>PORTB Weak Pull-up Current</b>						
			50	250	400	μA	$V_{DD} = 5.0\text{V}$ , $V_{PIN} = V_{SS}$	
D080	VOL	<b>Output Low Voltage<sup>(4)</sup></b>						
		I/O ports	—	—	VSS+0.6 VSS+0.6 VSS+0.6	V	IOL = 8 mA, VDD = 5V IOL = 6 mA, VDD = 3.3V IOL = 3 mA, VDD = VDDMIN	

\* These parameters are characterized but not tested.

† Data in "Typ" column is at 3.0V, 25°C unless otherwise stated. These parameters are for design guidance only and are not tested.

**Note 1:** In RC oscillator configuration, the OSC1/CLKIN pin is a Schmitt Trigger input. It is not recommended to use an external clock in RC mode.

**2:** Negative current is defined as current sourced by the pin.

**3:** The leakage current on the MCLR pin is strongly dependent on the applied voltage level. The specified levels represent normal operating conditions. Higher leakage current may be measured at different input voltages.

**4:** Including OSC2 in CLKOUT mode.

# PIC18(L)F1XK22

## 25.9 DC Characteristics: PIC18(L)F1XK22-I/E (Continued)

DC CHARACTERISTICS			Standard Operating Conditions (unless otherwise stated) Operating temperature $-40^{\circ}\text{C} \leq T_A \leq +85^{\circ}\text{C}$ for industrial $-40^{\circ}\text{C} \leq T_A \leq +125^{\circ}\text{C}$ for extended				
Param No.	Sym.	Characteristic	Min.	Typ†	Max.	Units	Conditions
D090	VOH	<b>Output High Voltage<sup>(4)</sup></b>					
		I/O ports	VDD-0.7 VDD-0.7 VDD-0.7	—	—	V	IOH = 3.5 mA, VDD = 5V IOH = 3 mA, VDD = 3.3V IOH = 2 mA, VDD = VDDMIN
<b>Capacitive Loading Specs on Output Pins</b>							
D101*	COSC2	OSC2 pin	—	—	15	pF	In XT, HS and LP modes when external clock is used to drive OSC1
D101A*	CIO	All I/O pins	—	—	50	pF	

\* These parameters are characterized but not tested.

† Data in "Typ" column is at 3.0V, 25°C unless otherwise stated. These parameters are for design guidance only and are not tested.

- Note 1:** In RC oscillator configuration, the OSC1/CLKIN pin is a Schmitt Trigger input. It is not recommended to use an external clock in RC mode.
- 2:** Negative current is defined as current sourced by the pin.
- 3:** The leakage current on the  $\overline{\text{MCLR}}$  pin is strongly dependent on the applied voltage level. The specified levels represent normal operating conditions. Higher leakage current may be measured at different input voltages.
- 4:** Including OSC2 in CLKOUT mode.

## 25.10 Memory Programming Requirements

DC CHARACTERISTICS			Standard Operating Conditions (unless otherwise stated) Operating temperature $-40^{\circ}\text{C} \leq T_A \leq +125^{\circ}\text{C}$				
Param No.	Sym.	Characteristic	Min.	Typ†	Max.	Units	Conditions
<b>Internal Program Memory Programming Specifications<sup>(1)</sup></b>							
D110	V <sub>PP</sub>	Voltage on $\overline{\text{MCLR}}/\text{VPP}/\text{RA3}$ pin	8	—	9	V	(Note 3, Note 4)
D113	I <sub>DDP</sub>	Supply Current during Programming	—	—	10	mA	
<b>Data EEPROM Memory<sup>(2)</sup></b>							
D120	ED	Byte Endurance	100K	—	—	E/W	-40°C to +85°C Using EECON to read/write
D121	V <sub>DRW</sub>	V <sub>DD</sub> for Read/Write	V <sub>DDMIN</sub>	—	V <sub>DDMAX</sub>	V	
D122	T <sub>DEW</sub>	Erase/Write Cycle Time	—	3	4	ms	Provided no other specifications are violated -40°C to +85°C
D123	T <sub>RETD</sub>	Characteristic Retention	—	40	—	Year	
D124	T <sub>REF</sub>	Number of Total Erase/Write Cycles before Refresh <sup>(2)</sup>	1M	10M	—	E/W	
<b>Program Flash Memory</b>							
D130	EP	Cell Endurance	10k	—	—	E/W	Temperature during programming: $10^{\circ}\text{C} \leq T_A \leq 40^{\circ}\text{C}$
D131	V <sub>PR</sub>	V <sub>DD</sub> for Read	V <sub>DDMIN</sub>	—	V <sub>DDMAX</sub>	V	
D131A		Voltage on $\overline{\text{MCLR}}/\text{VPP}$ during Erase/Program	8.0	—	9.0	V	Temperature during programming: $10^{\circ}\text{C} \leq T_A \leq 40^{\circ}\text{C}$
D131B	V <sub>BE</sub>	V <sub>DD</sub> for Bulk Erase	2.7	—	V <sub>DDMAX</sub>	V	Temperature during programming: $10^{\circ}\text{C} \leq T_A \leq 40^{\circ}\text{C}$
D132	V <sub>PEW</sub>	V <sub>DD</sub> for Write or Row Erase	2.2 V <sub>DDMIN</sub>	— —	V <sub>DDMAX</sub> V <sub>DDMAX</sub>	V	PIC18LF1XK22 PIC18F1XK22
D132A	I <sub>PPPGM</sub>	Current on $\overline{\text{MCLR}}/\text{VPP}$ during Erase/Write	—	1.0	—	mA	Temperature during programming: $10^{\circ}\text{C} \leq T_A \leq 40^{\circ}\text{C}$
D132B	I <sub>DDPGM</sub>	Current on V <sub>DD</sub> during Erase/Write	—	5.0	—	mA	Temperature during programming: $10^{\circ}\text{C} \leq T_A \leq 40^{\circ}\text{C}$
D133	T <sub>PEW</sub>	Erase/Write cycle time	—	2.0	2.8	ms	Temperature during programming: $10^{\circ}\text{C} \leq T_A \leq 40^{\circ}\text{C}$
D134	T <sub>RETD</sub>	Characteristic Retention	—	40	—	Year	Provided no other specifications are violated

† Data in "Typ" column is at 3.0V, 25°C unless otherwise stated. These parameters are for design guidance only and are not tested.

- Note 1:** These specifications are for programming the on-chip program memory through the use of table write instructions.  
**Note 2:** Refer to [Section 5.8 "Using the Data EEPROM"](#) for a more detailed discussion on data EEPROM endurance.  
**Note 3:** Required only if single-supply programming is disabled.  
**Note 4:** The MPLAB ICD 2 does not support variable V<sub>PP</sub> output. Circuitry to limit the ICD 2 V<sub>PP</sub> voltage must be placed between the ICD 2 and target system when programming or debugging with the ICD 2.

# PIC18(L)F1XK22

## 25.11 Thermal Considerations

Standard Operating Conditions (unless otherwise stated)					
Operating temperature $-40^{\circ}\text{C} \leq T_A \leq +125^{\circ}\text{C}$					
Param No.	Sym.	Characteristic	Typ.	Units	Conditions
TH01	$\theta_{JA}$	Thermal Resistance Junction to Ambient	62.2	$^{\circ}\text{C}/\text{W}$	20-pin PDIP package
			75.0	$^{\circ}\text{C}/\text{W}$	20-pin SOIC package
			89.3	$^{\circ}\text{C}/\text{W}$	20-pin SSOP package
			43.0	$^{\circ}\text{C}/\text{W}$	20-pin QFN 4x4mm package
TH02	$\theta_{JC}$	Thermal Resistance Junction to Case	27.5	$^{\circ}\text{C}/\text{W}$	20-pin PDIP package
			23.1	$^{\circ}\text{C}/\text{W}$	20-pin SOIC package
			31.1	$^{\circ}\text{C}/\text{W}$	20-pin SSOP package
			5.3	$^{\circ}\text{C}/\text{W}$	20-pin QFN 4x4mm package
TH03	$T_{JMAX}$	Maximum Junction Temperature	150	$^{\circ}\text{C}$	
TH04	PD	Power Dissipation	—	W	$PD = P_{INTERNAL} + P_{I/O}$
TH05	$P_{INTERNAL}$	Internal Power Dissipation	—	W	$P_{INTERNAL} = I_{DD} \times V_{DD}^{(1)}$
TH06	$P_{I/O}$	I/O Power Dissipation	—	W	$P_{I/O} = \sum (I_{OL} \times V_{OL}) + \sum (I_{OH} \times (V_{DD} - V_{OH}))$
TH07	$P_{DER}$	Derated Power	—	W	$P_{DER} = P_{DMAX} (T_J - T_A) / \theta_{JA}^{(2)}$

- Note** 1:  $I_{DD}$  is current to run the chip alone without driving any load on the output pins.  
2:  $T_A$  = Ambient Temperature.  
3:  $T_J$  = Junction Temperature.



## 25.12 Timing Parameter Symbology

The timing parameter symbols have been created with one of the following formats:

1. TppS2ppS
2. TppS

<b>T</b>			
F	Frequency	T	Time

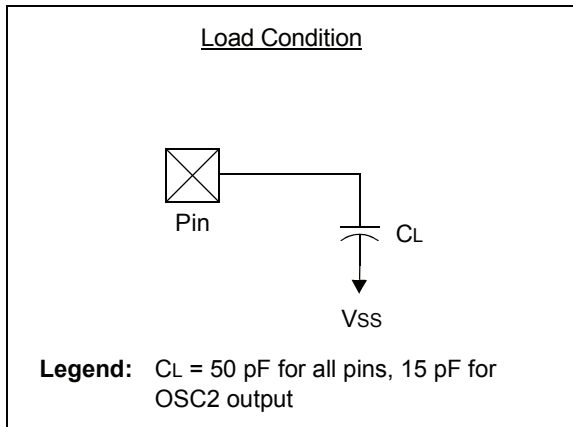
Lowercase letters (pp) and their meanings:

<b>pp</b>			
cc	CCP1	osc	OSC1
ck	CLKOUT	rd	$\overline{RD}$
cs	$\overline{CS}$	rw	$\overline{RD}$ or $\overline{WR}$
di	SDI	sc	SCK
do	SDO	ss	$\overline{SS}$
dt	Data in	t0	T0CKI
io	I/O PORT	t1	T1CKI
mc	MCLR	wr	$\overline{WR}$

Uppercase letters and their meanings:

<b>S</b>			
F	Fall	P	Period
H	High	R	Rise
I	Invalid (High-impedance)	V	Valid
L	Low	Z	High-impedance

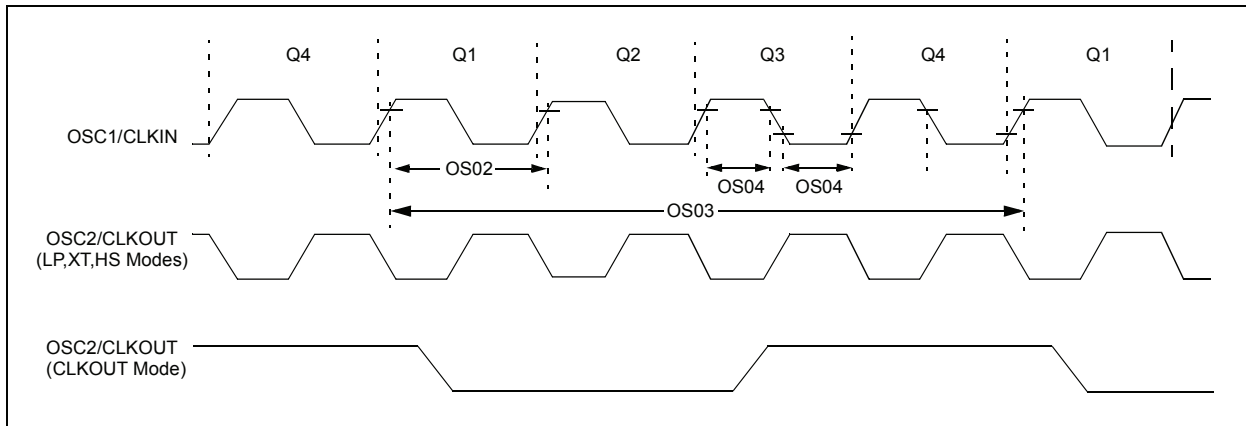
**FIGURE 25-7: LOAD CONDITIONS**



# PIC18(L)F1XK22

## 25.13 AC Characteristics: PIC18(L)F1XK22-I/E

**FIGURE 25-8: CLOCK TIMING**



**TABLE 25-1: EXTERNAL CLOCK TIMING REQUIREMENTS**

Param. No.	Symbol	Characteristic	Min	Max	Units	Conditions
1A	FOSC	External CLKIN Frequency <sup>(1)</sup>	DC	48	MHz	EC, ECIO Oscillator mode, (Extended Range Devices)
			DC	64	MHz	EC, ECIO Oscillator mode, (Industrial Range Devices)
	Oscillator Frequency <sup>(1)</sup>	DC	4	MHz	RC Oscillator mode	
		0.1	4	MHz	XT Oscillator mode	
		4	25	MHz	HS Oscillator mode	
		4	16	MHz	HS + PLL Oscillator mode, (Industrial Range Devices)	
		4	12	MHz	HS + PLL Oscillator mode, (Extended Range Devices)	
5	33	kHz	LP Oscillator mode			
1	TOSC	External CLKIN Period <sup>(1)</sup>	20.8	—	ns	EC, ECIO, Oscillator mode (Extended Range Devices)
			15.6	—	ns	EC, ECIO, Oscillator mode, (Industrial Range Devices)
	Oscillator Period <sup>(1)</sup>	250	—	ns	RC Oscillator mode	
		250	10,000	ns	XT Oscillator mode	
		40	250	ns	HS Oscillator mode	
		62.5	250	ns	HS + PLL Oscillator mode, (Industrial range devices)	
		83.3	250	ns	HS + PLL Oscillator mode, (Extended Range Devices)	
30	200	μs	LP Oscillator mode			
2	T <sub>CY</sub>	Instruction Cycle Time <sup>(1)</sup>	62.5	—	ns	T <sub>CY</sub> = 4/FOSC
3	T <sub>oS</sub> L, T <sub>oS</sub> H	External Clock in (OSC1) High or Low Time	30	—	ns	XT Oscillator mode
			2.5	—	μs	LP Oscillator mode
			10	—	ns	HS Oscillator mode
4	T <sub>oS</sub> R, T <sub>oS</sub> F	External Clock in (OSC1) Rise or Fall Time	—	20	ns	XT Oscillator mode
			—	50	ns	LP Oscillator mode
			—	7.5	ns	HS Oscillator mode

**Note 1:** Instruction cycle period (T<sub>CY</sub>) equals four times the input oscillator time base period for all configurations except PLL. All specified values are based on characterization data for that particular oscillator type under standard operating conditions with the device executing code. Exceeding these specified limits may result in an unstable oscillator operation and/or higher than expected current consumption. All devices are tested to operate at “min.” values with an external clock applied to the OSC1/CLKIN pin. When an external clock input is used, the “max.” cycle time limit is “DC” (no clock) for all devices.

# PIC18(L)F1XK22

**TABLE 25-2: OSCILLATOR PARAMETERS**

Standard Operating Conditions (unless otherwise stated)								
Operating Temperature $-40^{\circ}\text{C} \leq T_A \leq +125^{\circ}\text{C}$								
Param No.	Sym.	Characteristic	Freq. Tolerance	Min.	Typ†	Max.	Units	Conditions
OS08	HFosc	Internal Calibrated HFINTOSC Frequency <sup>(2)</sup>	$\pm 2\%$	—	16.0	—	MHz	$0^{\circ}\text{C} \leq T_A \leq 60^{\circ}\text{C}$
			$\pm 3\%$	—	16.0	—	MHz	$60^{\circ}\text{C} \leq T_A \leq +85^{\circ}\text{C}$
			$\pm 5\%$	—	16.0	—	MHz	
OS09	LFosc	Internal LFINTOSC Frequency	0	—	31.25	—	kHz	
OS10*	Tiosc st	HFINTOSC Wake-up from Sleep Start-up Time	—	—	5	8	$\mu\text{s}$	$V_{DD} = 2.0\text{V}, -40^{\circ}\text{C} \text{ to } +85^{\circ}\text{C}$
			—	—	5	8	$\mu\text{s}$	$V_{DD} = 3.0\text{V}, -40^{\circ}\text{C} \text{ to } +85^{\circ}\text{C}$
			—	—	5	8	$\mu\text{s}$	$V_{DD} = 5.0\text{V}, -40^{\circ}\text{C} \text{ to } +85^{\circ}\text{C}$

\* These parameters are characterized but not tested.

† Data in "Typ" column is at 3.0V, 25°C unless otherwise stated. These parameters are for design guidance only and are not tested.

**Note 1:** Instruction cycle period ( $T_{CY}$ ) equals four times the input oscillator time base period. All specified values are based on characterization data for that particular oscillator type under standard operating conditions with the device executing code. Exceeding these specified limits may result in an unstable oscillator operation and/or higher than expected current consumption. All devices are tested to operate at "min" values with an external clock applied to the OSC1 pin. When an external clock input is used, the "max" cycle time limit is "DC" (no clock) for all devices.

**2:** To ensure these oscillator frequency tolerances,  $V_{DD}$  and  $V_{SS}$  must be capacitively decoupled as close to the device as possible. 0.1  $\mu\text{F}$  and 0.01  $\mu\text{F}$  values in parallel are recommended.

**3:** By design.

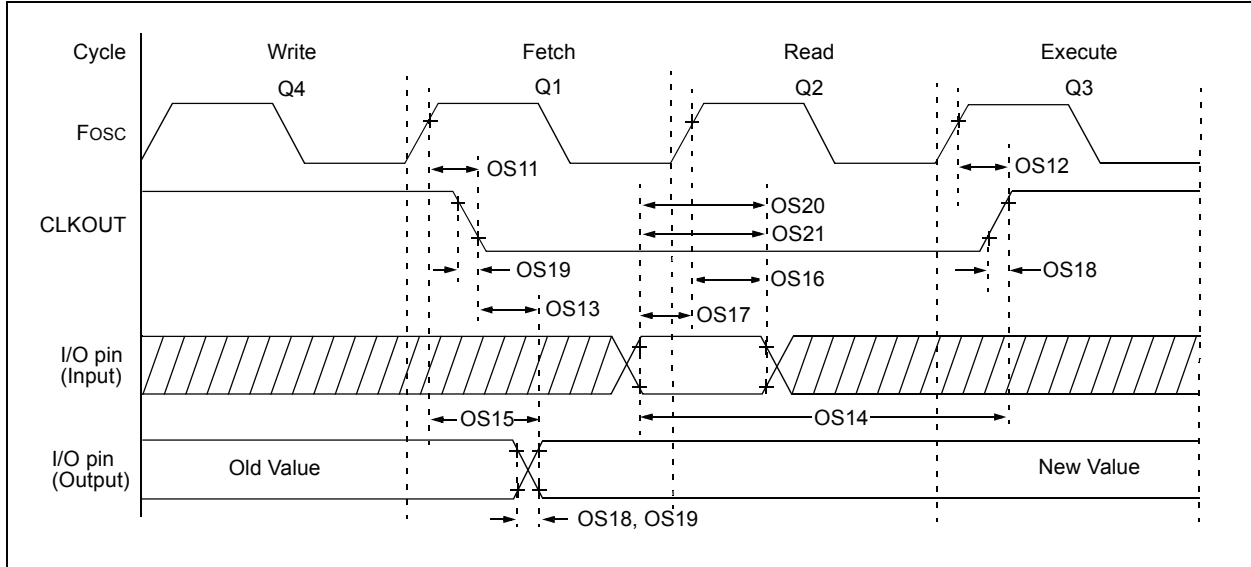
**TABLE 25-3: PLL CLOCK TIMING SPECIFICATIONS ( $V_{DD} = 1.8\text{V TO } 5.5\text{V}$ )**

Param No.	Sym.	Characteristic	Min.	Typ†	Max.	Units	Conditions
F10	FOSC	Oscillator Frequency Range	4	—	5	MHz	$V_{DD} = 1.8\text{-}3.0\text{V}$
			4	—	16	MHz	$V_{DD} = 3.0\text{-}5.0\text{V}, -40^{\circ}\text{C} \text{ to } +85^{\circ}\text{C}$
			4	—	12	MHz	$V_{DD} = 3.0\text{-}5.0\text{V}, 125^{\circ}\text{C}$
F11	FSYS	On-Chip VCO System Frequency	16	—	20	MHz	$V_{DD} = 1.8\text{-}3.0\text{V}$
			16	—	64	MHz	$V_{DD} = 3.0\text{-}5.0\text{V}, -40^{\circ}\text{C} \text{ to } +85^{\circ}\text{C}$
			16	—	48	MHz	$V_{DD} = 3.0\text{-}5.0\text{V}, 125^{\circ}\text{C}$
F12	$t_{rc}$	PLL Start-up Time (Lock Time)	—	—	2	ms	
F13*	$\Delta\text{CLK}$	CLKOUT Stability (Jitter)	-0.25	—	+0.25	%	

\* These parameters are characterized but not tested.

† Data in "Typ" column is at 3V, 25°C unless otherwise stated. These parameters are for design guidance only and are not tested.

**FIGURE 25-9: CLKOUT AND I/O TIMING**



**TABLE 25-4: CLKOUT AND I/O TIMING PARAMETERS**

Standard Operating Conditions (unless otherwise stated)							
Operating Temperature $-40^{\circ}\text{C} \leq T_A \leq +125^{\circ}\text{C}$							
Param No.	Sym.	Characteristic	Min.	Typ†	Max.	Units	Conditions
OS11	TosH2ckL	Fosc $\uparrow$ to CLKOUT $\downarrow$ <sup>(1)</sup>	—	—	70	ns	VDD = 3.3-5.0V
OS12	TosH2ckH	Fosc $\uparrow$ to CLKOUT $\uparrow$ <sup>(1)</sup>	—	—	72	ns	VDD = 3.3-5.0V
OS13	TckL2ioV	CLKOUT $\downarrow$ to Port out valid <sup>(1)</sup>	—	—	20	ns	
OS14	TioV2ckH	Port input valid before CLKOUT $\uparrow$ <sup>(1)</sup>	TOSC + 200 ns	—	—	ns	
OS15	TosH2ioV	Fosc $\uparrow$ (Q1 cycle) to Port out valid	—	50	70*	ns	VDD = 3.3-5.0V
OS16	TosH2ioL	Fosc $\uparrow$ (Q2 cycle) to Port input invalid (I/O in hold time)	50	—	—	ns	VDD = 3.3-5.0V
OS17	TioV2osH	Port input valid to Fosc $\uparrow$ (Q2 cycle) (I/O in setup time)	20	—	—	ns	
OS18	TioR	Port output rise time <sup>(2)</sup>	—	40 15	72 32	ns	VDD = 1.8V VDD = 3.3-5.0V
OS19	TioF	Port output fall time <sup>(2)</sup>	—	28 15	55 30	ns	VDD = 1.8V VDD = 3.3-5.0V
OS20*	Tinp	INT pin input high or low time	25	—	—	ns	
OS21*	Trbp	PORTB interrupt-on-change new input level time	25	—	—	ns	

\* These parameters are characterized but not tested.

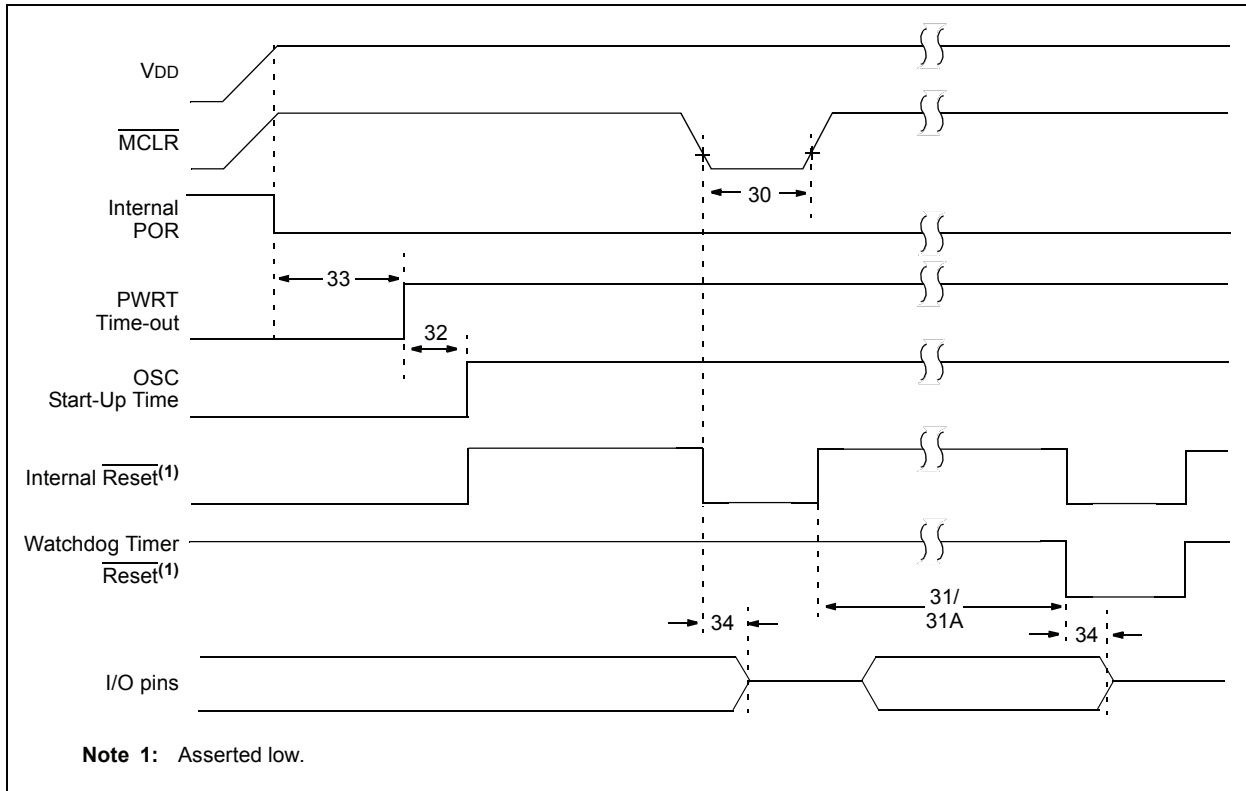
† Data in "Typ" column is at 3.0V, 25°C unless otherwise stated.

**Note 1:** Measurements are taken in RC mode where CLKOUT output is 4 x TOSC.

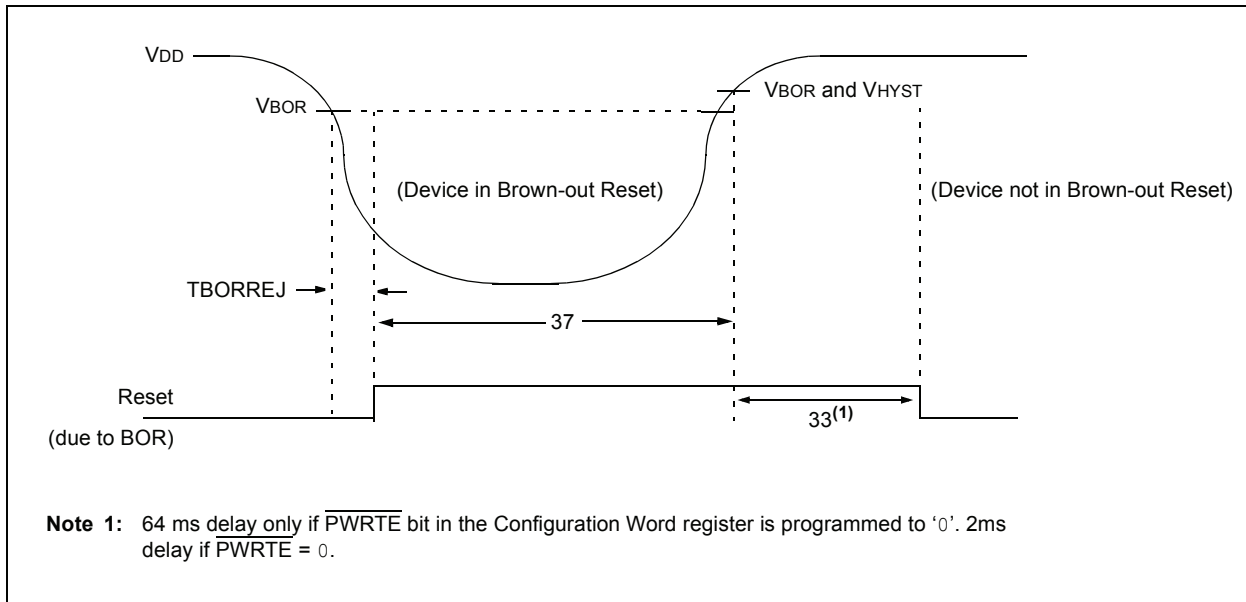
**Note 2:** Includes OSC2 in CLKOUT mode.

# PIC18(L)F1XK22

**FIGURE 25-10: RESET, WATCHDOG TIMER, OSCILLATOR START-UP TIMER AND POWER-UP TIMER TIMING**



**FIGURE 25-11: BROWN-OUT RESET TIMING AND CHARACTERISTICS**



**TABLE 25-5: RESET, WATCHDOG TIMER, OSCILLATOR START-UP TIMER, POWER-UP TIMER, AND BROWN-OUT RESET PARAMETERS**

Standard Operating Conditions (unless otherwise stated)							
Operating Temperature $-40^{\circ}\text{C} \leq T_A \leq +125^{\circ}\text{C}$							
Param No.	Sym.	Characteristic	Min.	Typ†	Max.	Units	Conditions
30	TMCL	$\overline{\text{MCLR}}$ Pulse Width (low)	2	—	—	$\mu\text{s}$	$V_{DD} = 3.3\text{-}5\text{V}$ , $-40^{\circ}\text{C}$ to $+85^{\circ}\text{C}$
			5	—	—	$\mu\text{s}$	$V_{DD} = 3.3\text{-}5\text{V}$
31	TWDT	Standard Watchdog Timer Time-out Period (1:16 Prescaler)	10	17	27	ms	$V_{DD} = 3.3\text{V-}5\text{V}$ , $-40^{\circ}\text{C}$ to $+85^{\circ}\text{C}$
			10	17	30	ms	$V_{DD} = 3.3\text{V-}5\text{V}$
31A	TWDTL P	Low Power Watchdog Timer Time-out Period (No Prescaler)	10	18	27	ms	$V_{DD} = 3.3\text{V-}5\text{V}$ , $-40^{\circ}\text{C}$ to $+85^{\circ}\text{C}$
			10	18	33	ms	$V_{DD} = 3.3\text{V-}5\text{V}$
32	TOST	Oscillator Start-up Timer Period <sup>(1), (2)</sup>	—	1024	—	Tosc	<b>(Note 3)</b>
33*	TPWRT	Power-up Timer Period, $\overline{\text{PWRTE}} = 0$	40	65	140	ms	
34*	TIOZ	I/O high-impedance from $\overline{\text{MCLR}}$ Low or Watchdog Timer Reset	—	—	2.73	$\mu\text{s}$	
35	VBOR	Brown-out Reset Voltage	1.75	1.9	2.05	V	$\text{BORV} = 1.9\text{V}^{(5)}$
			2.05	2.2	2.35	V	$\text{BORV} = 2.2\text{V}^{(5)}$
			2.35	2.5	2.65	V	$\text{BORV} = 2.7\text{V}$
			2.65	2.85	3.05	V	$\text{BORV} = 2.85\text{V}$
36*	VHYST	Brown-out Reset Hysteresis	0	25	50	mV	$-40^{\circ}\text{C}$ to $+85^{\circ}\text{C}$
37*	TBORDC	Brown-out Reset DC Response Time	0	3	35	$\mu\text{s}$	$V_{DD} \leq V_{BOR}$

\* These parameters are characterized but not tested.

† Data in "Typ" column is at 3V, 25°C unless otherwise stated. These parameters are for design guidance only and are not tested.

**Note 1:** Instruction cycle period ( $T_{CY}$ ) equals four times the input oscillator time base period. All specified values are based on characterization data for that particular oscillator type under standard operating conditions with the device executing code. Exceeding these specified limits may result in an unstable oscillator operation and/or higher than expected current consumption. All devices are tested to operate at "min" values with an external clock applied to the OSC1 pin. When an external clock input is used, the "max" cycle time limit is "DC" (no clock) for all devices.

2: By design.

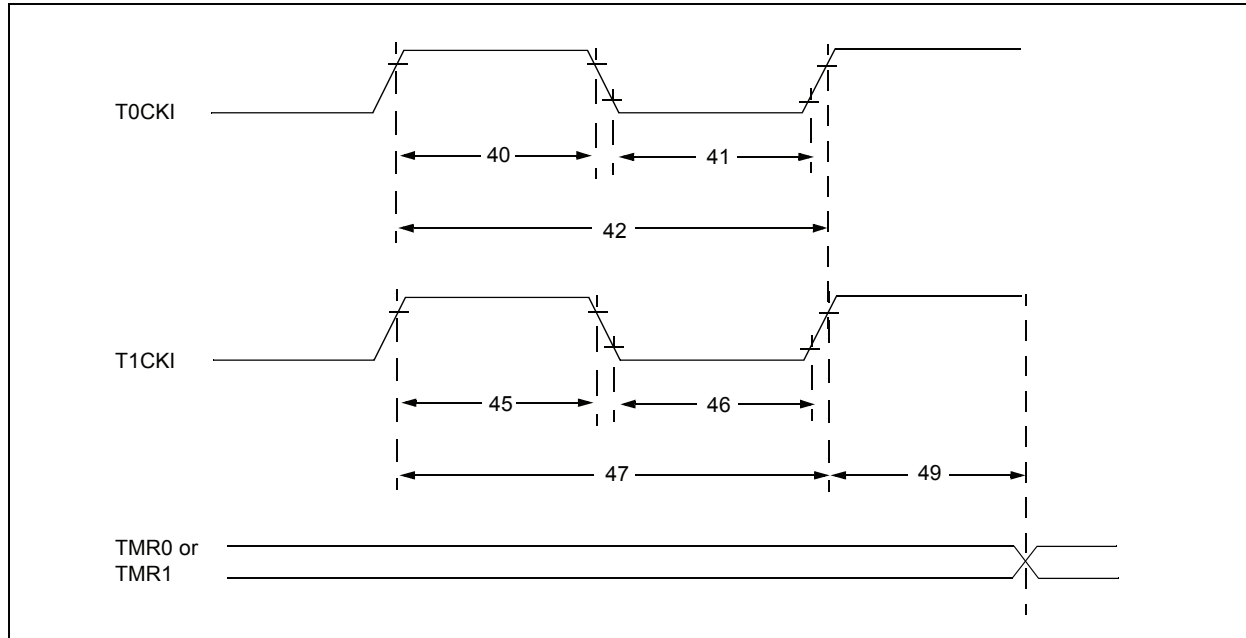
3: Period of the slower clock.

4: To ensure these voltage tolerances,  $V_{DD}$  and  $V_{SS}$  must be capacitively decoupled as close to the device as possible. 0.1  $\mu\text{F}$  and 0.01  $\mu\text{F}$  values in parallel are recommended.

5: PIC18LF1XK22 devices only.

# PIC18(L)F1XK22

**FIGURE 25-12: TIMER0 AND TIMER1 EXTERNAL CLOCK TIMINGS**



**TABLE 25-6: TIMER0 AND TIMER1 EXTERNAL CLOCK REQUIREMENTS**

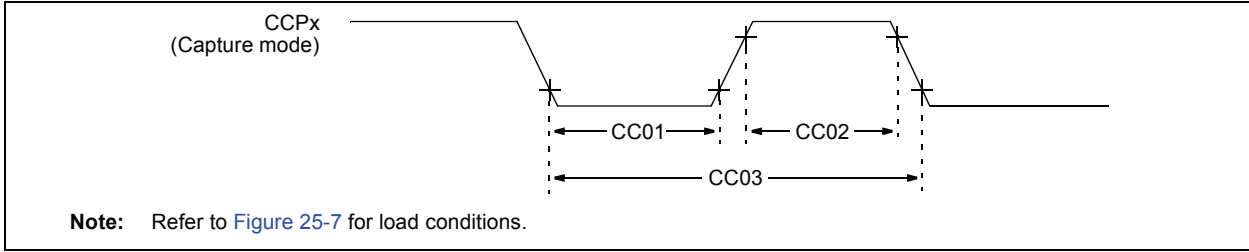
Standard Operating Conditions (unless otherwise stated)								
Operating Temperature $-40^{\circ}\text{C} \leq T_A \leq +125^{\circ}\text{C}$								
Param No.	Sym.	Characteristic		Min.	Typ†	Max.	Units	Conditions
40*	T <sub>T0H</sub>	T0CKI High Pulse Width	No Prescaler	$0.5 T_{CY} + 20$	—	—	ns	
			With Prescaler	10	—	—	ns	
41*	T <sub>T0L</sub>	T0CKI Low Pulse Width	No Prescaler	$0.5 T_{CY} + 20$	—	—	ns	
			With Prescaler	10	—	—	ns	
42*	T <sub>T0P</sub>	T0CKI Period		Greater of: $20$ or $\frac{T_{CY} + 40}{N}$	—	—	ns	N = prescale value (2, 4, ..., 256)
45*	T <sub>T1H</sub>	T1CKI High Time	Synchronous, No Prescaler	$0.5 T_{CY} + 20$	—	—	ns	
			Synchronous, with Prescaler	15	—	—	ns	
			Asynchronous	30	—	—	ns	
46*	T <sub>T1L</sub>	T1CKI Low Time	Synchronous, No Prescaler	$0.5 T_{CY} + 20$	—	—	ns	
			Synchronous, with Prescaler	15	—	—	ns	
			Asynchronous	30	—	—	ns	
47*	T <sub>T1P</sub>	T1CKI Input Period	Synchronous	Greater of: $30$ or $\frac{T_{CY} + 40}{N}$	—	—	ns	N = prescale value (1, 2, 4, 8)
			Asynchronous	60	—	—	ns	
48	F <sub>T1</sub>	Timer1 Oscillator Input Frequency Range (oscillator enabled by setting bit T1OSCEN)		32.4	32.768	33.1	kHz	
49*	TCKEZTMR1	Delay from External Clock Edge to Timer Increment		2 T <sub>OSC</sub>	—	7 T <sub>OSC</sub>	—	Timers in Sync mode

\* These parameters are characterized but not tested.

† Data in "Typ" column is at 3V, 25°C unless otherwise stated. These parameters are for design guidance only and are not tested.



**FIGURE 25-13: CAPTURE/COMPARE/PWM TIMINGS (CCP)**



**TABLE 25-7: CAPTURE/COMPARE/PWM REQUIREMENTS (CCP)**

Standard Operating Conditions (unless otherwise stated)								
Operating Temperature $-40^{\circ}\text{C} \leq T_A \leq +125^{\circ}\text{C}$								
Param No.	Sym.	Characteristic		Min.	Typ†	Max.	Units	Conditions
CC01*	TccL	CCPx Input Low Time	No Prescaler	$0.5T_{CY} + 20$	—	—	ns	
			With Prescaler	20	—	—	ns	
CC02*	TccH	CCPx Input High Time	No Prescaler	$0.5T_{CY} + 20$	—	—	ns	
			With Prescaler	20	—	—	ns	
CC03*	TccP	CCPx Input Period		$\frac{3T_{CY} + 40}{N}$	—	—	ns	N = prescale value (1, 4 or 16)

\* These parameters are characterized but not tested.

† Data in "Typ" column is at 3V, 25°C unless otherwise stated. These parameters are for design guidance only and are not tested.

**TABLE 25-8: PIC18(L)F1XK22 A/D CONVERTER (ADC) CHARACTERISTICS:**

Standard Operating Conditions (unless otherwise stated)							
Operating temperature Tested at 25°C							
Param No.	Sym.	Characteristic	Min.	Typ†	Max.	Units	Conditions
AD01	NR	Resolution	—	—	10	bit	
AD02	EIL	Integral Error	—	—	$\pm 2$	LSb	$V_{REF} = 3.0\text{V}$
AD03	EDL	Differential Error	—	—	$\pm 1.5$	LSb	No missing codes $V_{REF} = 3.0\text{V}$
AD04	E <sub>OFF</sub>	Offset Error	—	—	$\pm 3$	LSb	$V_{REF} = 3.0\text{V}$
AD05	E <sub>GN</sub>	Gain Error	—	—	$\pm 3$	LSb	$V_{REF} = 3.0\text{V}$
AD06	V <sub>REF</sub>	Change in Reference Voltage = $V_{REF+} - V_{REF-}$ (2), (3)	1.8	—	V <sub>DD</sub>	V	$1.8 \leq V_{REF+} \leq V_{DD} + 0.3\text{V}$ $V_{SS} - 0.3\text{V} \leq V_{REF-} \leq V_{REF+} - 1.8\text{V}$
AD07	V <sub>AIN</sub>	Full-Scale Range	V <sub>SS</sub>	—	V <sub>REF</sub>	V	
AD08	Z <sub>AIN</sub>	Recommended Impedance of Analog Voltage Source	—	—	10	kΩ	Can go higher if external 0.01μF capacitor is present on input pin.

\* These parameters are characterized but not tested.

† Data in "Typ" column is at 3.0V, 25°C unless otherwise stated. These parameters are for design guidance only and are not tested.

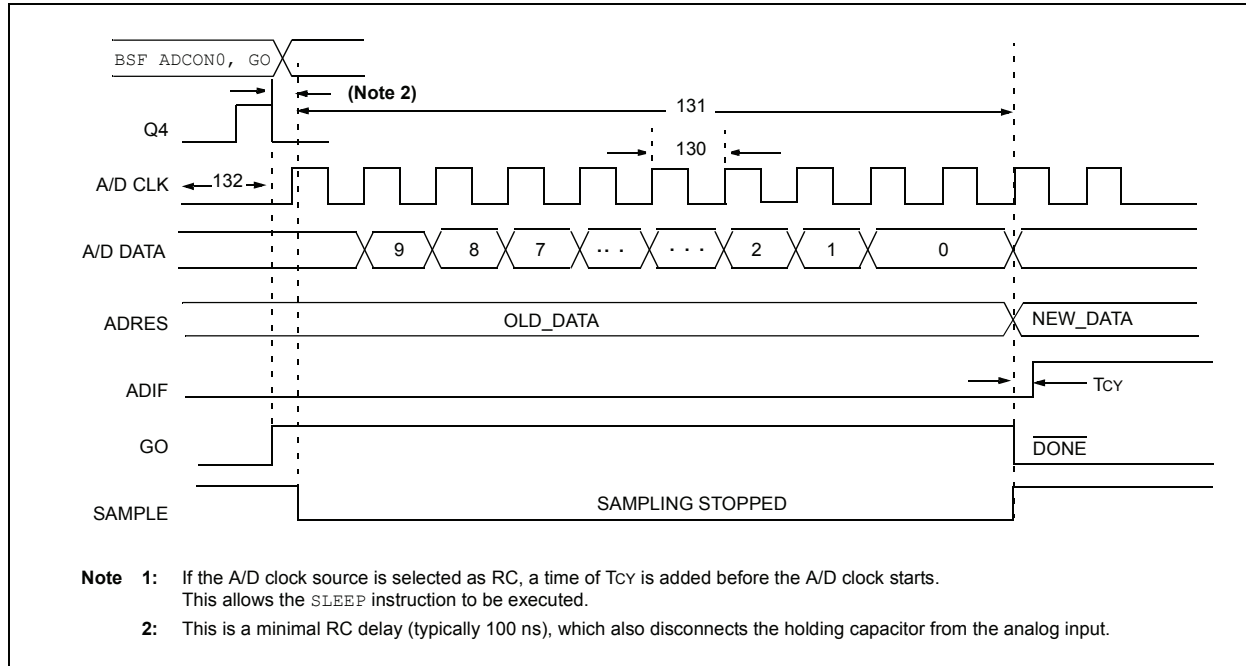
**Note 1:** Total Absolute Error includes integral, differential, offset and gain errors.

**Note 2:** ADC V<sub>REF</sub> is from external V<sub>REF</sub>, V<sub>DD</sub> pin or FVR, whichever is selected as reference input.

**Note 3:** FVR voltage selected must be 2.048V or 4.096V.

# PIC18(L)F1XK22

**FIGURE 25-14: A/D CONVERSION TIMING**



**TABLE 25-9: A/D CONVERSION REQUIREMENTS**

Param No.	Symbol	Characteristic	Min.	Max.	Units	Conditions
130*	TAD	A/D Clock Period	0.7	25.0 <sup>(1)</sup>	μs	TOSC based, VREF ≥ 3.0V, -40°C to +85°C
			0.7	4.0 <sup>(1)</sup>	μs	TOSC based, VREF ≥ 3.0V, -40°C to +125°C
			1.0	4.0	μs	A/D RC mode
131	Tcnv	Conversion Time (not including acquisition time) <sup>(2)</sup>	12	12	TAD	
132*	TACQ	Acquisition Time <sup>(3)</sup>	1.4	5.0	μs	VDD ≥ 3.0V, Rs = 50Ω
135	Tswc	Switching Time from Convert - Sample	—	— <sup>(4)</sup>	—	
136	Tdis	Discharge Time	2	2	μs	

\* These parameters are characterized but not tested.

- Note 1:** The time of the A/D clock period is dependent on the device frequency and the TAD clock divider.
- Note 2:** ADRES register may be read on the following Tcy cycle.
- Note 3:** The time for the holding capacitor to acquire the 'new' input voltage when the voltage changes full scale after the conversion (VDD to VSS or VSS to VDD). The source impedance (Rs) on the input channels is 50.
- Note 4:** On the following cycle of the device clock.

**TABLE 25-10: COMPARATOR SPECIFICATIONS**

Operating Conditions: 1.8V < V <sub>DD</sub> < 3.6V, -40°C < T <sub>A</sub> < +125°C (unless otherwise stated).							
Param No.	Sym	Characteristics	Min	Typ	Max	Units	Comments
CM01	V <sub>IOFF</sub>	Input Offset Voltage	—	10	50	mV	V <sub>REF</sub> = V <sub>DD</sub> /2, High Power Mode
			—	12	80	mV	V <sub>REF</sub> = V <sub>DD</sub> /2, Low Power Mode
CM02	V <sub>ICM</sub>	Input Common-mode Voltage	V <sub>SS</sub>	—	V <sub>DD</sub>	V	
CM04	T <sub>RESP</sub>	Response Time	—	200	400	ns	High Power Mode
			—	300	600	ns	Low Power Mode
CM05	T <sub>MC2OV</sub>	Comparator Mode Change to Output Valid*	—	—	10	μs	

\* These parameters are characterized but not tested.

**Note 1:** Response time measured with one comparator input at V<sub>DD</sub>/2, while the other input transitions from V<sub>SS</sub> to V<sub>DD</sub>.

**TABLE 25-11: DIGITAL-TO-ANALOG CONVERTER (DAC) SPECIFICATIONS**

Operating Conditions: 1.8V < V <sub>DD</sub> < 5.5V, -40°C < T <sub>A</sub> < +125°C (unless otherwise stated).							
Param No.	Sym.	Characteristics	Min.	Typ.	Max.	Units	Comments
DAC01*	CLSB	Step Size	—	V <sub>DD</sub> /32	—	V	
DAC02*	CACC	Absolute Accuracy	—	—	± 1/2	LSb	
DAC03*	CR	Unit Resistor Value (R)	—	5k	—	Ω	
DAC04*	CST	Settling Time <sup>(1)</sup>	—	—	10	μs	

\* These parameters are characterized but not tested.

**Note 1:** Settling time measured while DACR<4:0> transitions from '0000' to '1111'.

**TABLE 25-12: FIXED VOLTAGE REFERENCE (FVR) SPECIFICATIONS**

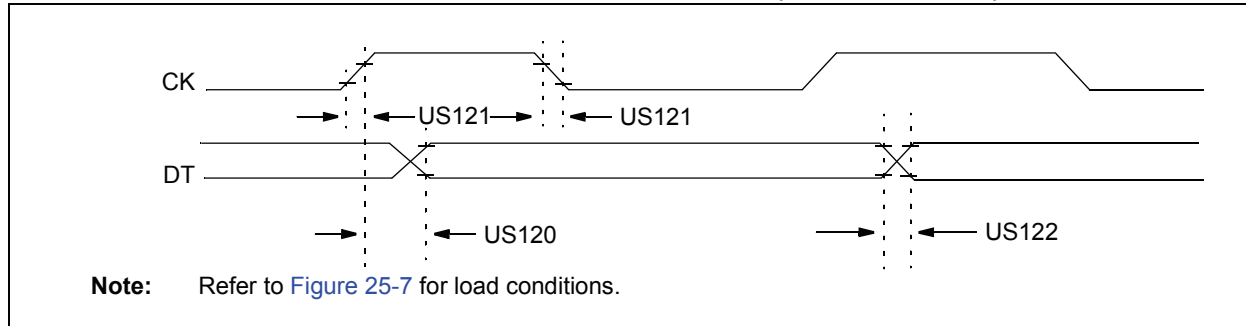
Operating Conditions: 1.8V < V <sub>DD</sub> < 5.5V, -40°C < T <sub>A</sub> < +85°C (unless otherwise stated).							
VR Voltage Reference Specifications				Standard Operating Conditions (unless otherwise stated)			
				Operating temperature -40°C ≤ T <sub>A</sub> ≤ +85°C -40°C ≤ T <sub>A</sub> ≤ +125°C			
Param No.	Sym.	Characteristics	Min.	Typ.	Max.	Units	Comments
D003	V <sub>ADFVR</sub>	Fixed Voltage Reference Voltage for ADC, Initial Accuracy	-8	—	6	%	1.024V, V <sub>DD</sub> ≥ 2.5V <sup>(1)</sup> 2.048V, V <sub>DD</sub> ≥ 2.5V 4.096V, V <sub>DD</sub> ≥ 4.75V
D003A	V <sub>CDAFVR</sub>	Fixed Voltage Reference Voltage for Comparator and DAC, Initial Accuracy	-11	—	7	%	1.024V, V <sub>DD</sub> ≥ 2.5V 2.048V, V <sub>DD</sub> ≥ 2.5V 4.096V, V <sub>DD</sub> ≥ 4.75V
D004*	SV <sub>DD</sub>	V <sub>DD</sub> Rise Rate to ensure internal Power-on Reset signal	0.05	—	—	V/ms	See Section 21.3 "Power-on Reset (POR)" for details.

\* These parameters are characterized but not tested.

**Note 1:** For proper operation, the minimum value of the ADC positive voltage reference must be 1.8V or greater. When selecting the FVR or the V<sub>REF+</sub> pin as the source of the ADC positive voltage reference, be aware that the voltage must be 1.8V or greater.

# PIC18(L)F1XK22

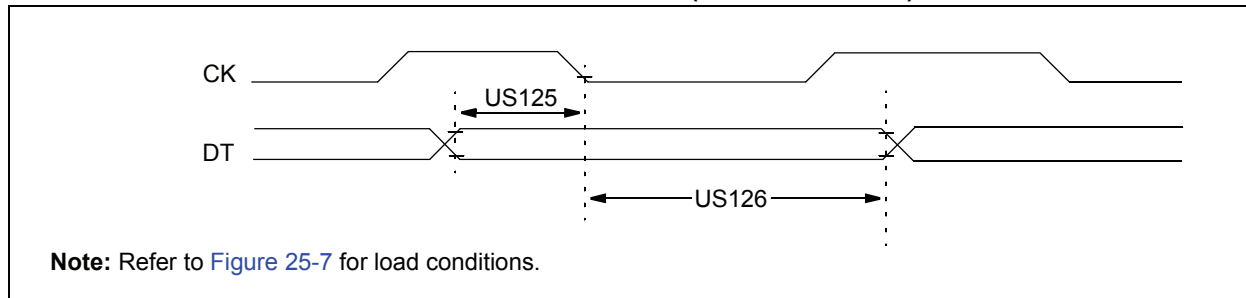
**FIGURE 25-15: USART SYNCHRONOUS TRANSMISSION (MASTER/SLAVE) TIMING**



**TABLE 25-13: USART SYNCHRONOUS TRANSMISSION REQUIREMENTS**

Standard Operating Conditions (unless otherwise stated)							
Operating Temperature $-40^{\circ}\text{C} \leq T_A \leq +125^{\circ}\text{C}$							
Param. No.	Symbol	Characteristic	Min.	Max.	Units	Conditions	
US120	TCKH2DTV	SYNC XMIT (Master and Slave)	3.0-5.5V	—	80	ns	
		Clock high to data-out valid	1.8-5.5V	—	100	ns	
US121	TCKRF	Clock out rise time and fall time (Master mode)	3.0-5.5V	—	45	ns	
			1.8-5.5V	—	50	ns	
US122	TDTRF	Data-out rise time and fall time	3.0-5.5V	—	45	ns	
			1.8-5.5V	—	50	ns	

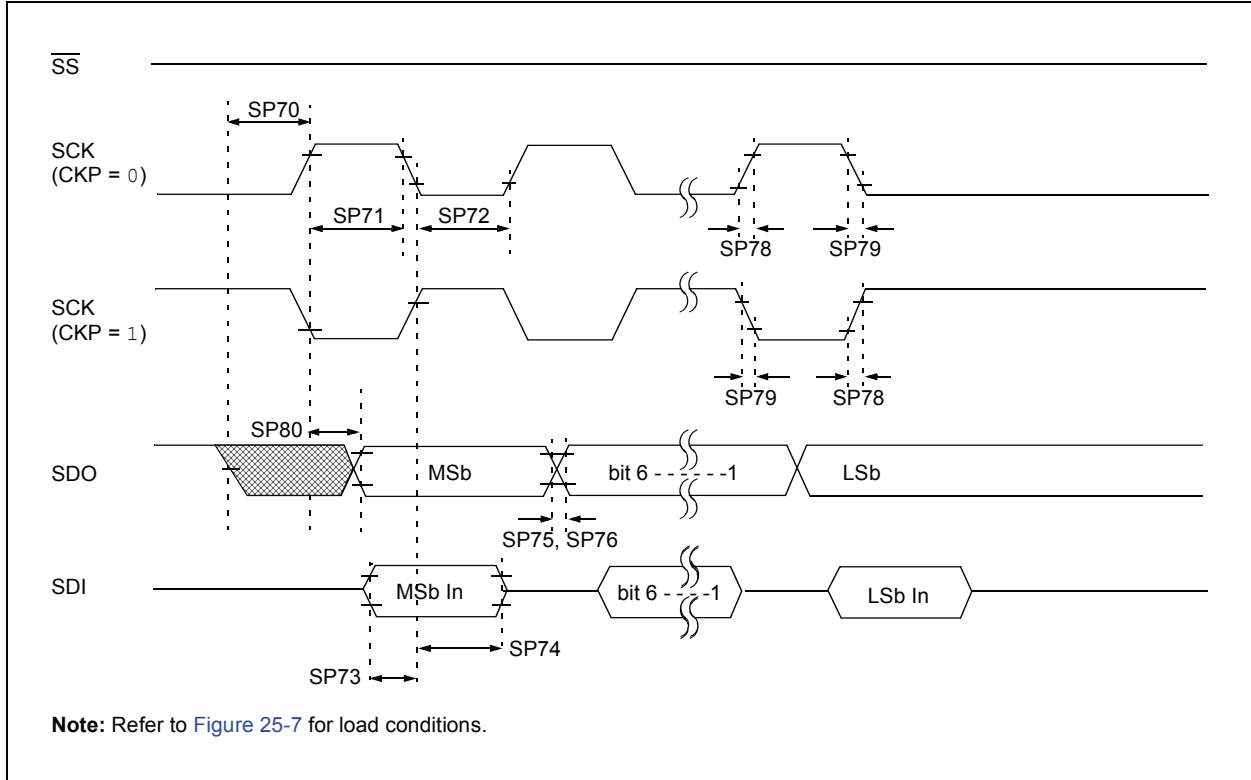
**FIGURE 25-16: USART SYNCHRONOUS RECEIVE (MASTER/SLAVE) TIMING**



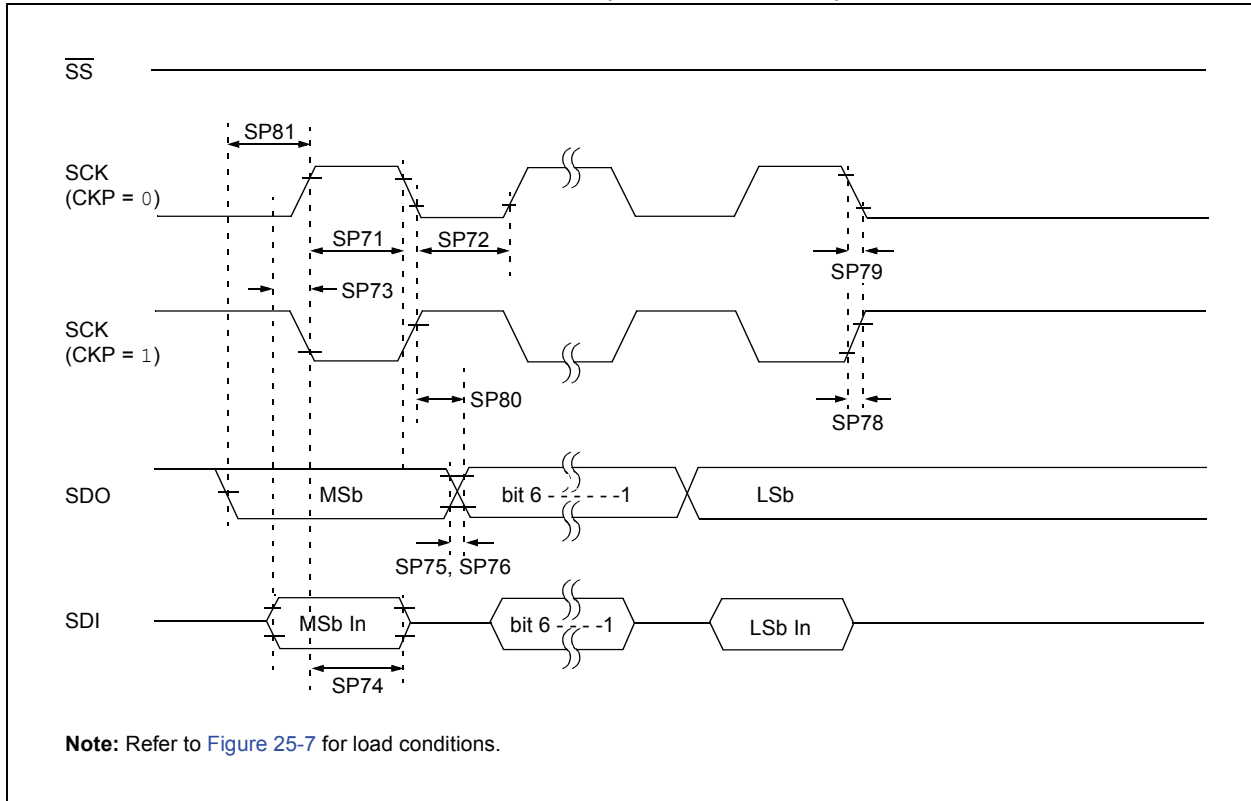
**TABLE 25-14: USART SYNCHRONOUS RECEIVE REQUIREMENTS**

Standard Operating Conditions (unless otherwise stated)							
Operating Temperature $-40^{\circ}\text{C} \leq T_A \leq +125^{\circ}\text{C}$							
Param. No.	Symbol	Characteristic	Min.	Max.	Units	Conditions	
US125	TDTV2CKL	SYNC RCV (Master and Slave)					
		Data-hold before CK $\downarrow$ (DT hold time)	10	—	ns		
US126	TCKL2DTL	Data-hold after CK $\downarrow$ (DT hold time)	15	—	ns		

**FIGURE 25-17: SPI MASTER MODE TIMING (CKE = 0, SMP = 0)**

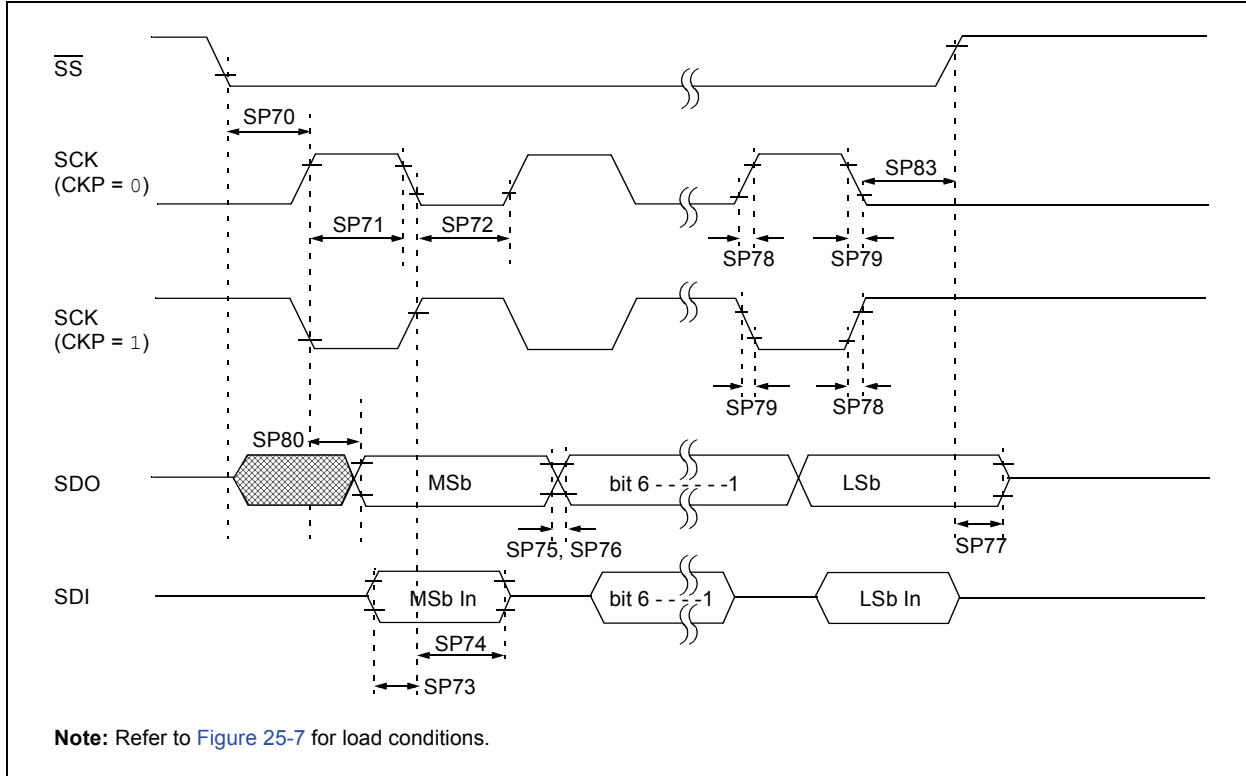


**FIGURE 25-18: SPI MASTER MODE TIMING (CKE = 1, SMP = 1)**

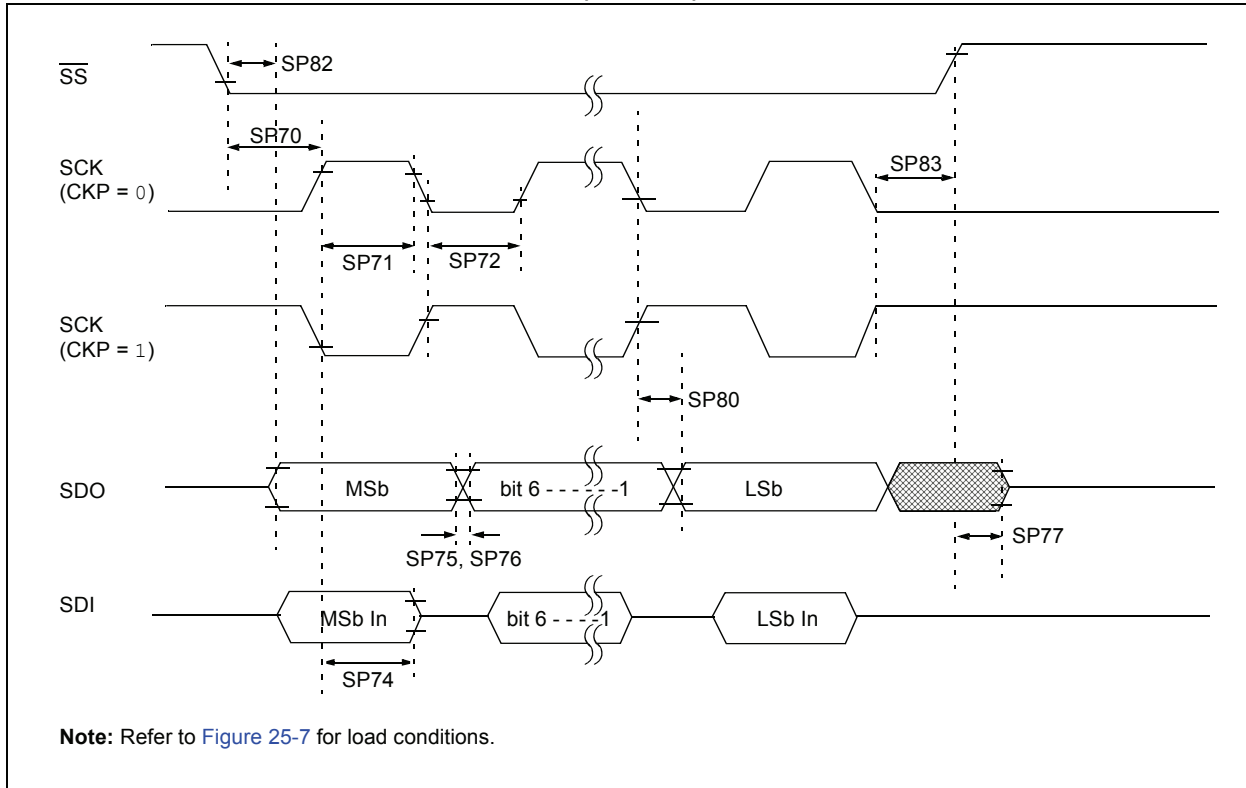


# PIC18(L)F1XK22

**FIGURE 25-19: SPI SLAVE MODE TIMING (CKE = 0)**



**FIGURE 25-20: SPI SLAVE MODE TIMING (CKE = 1)**



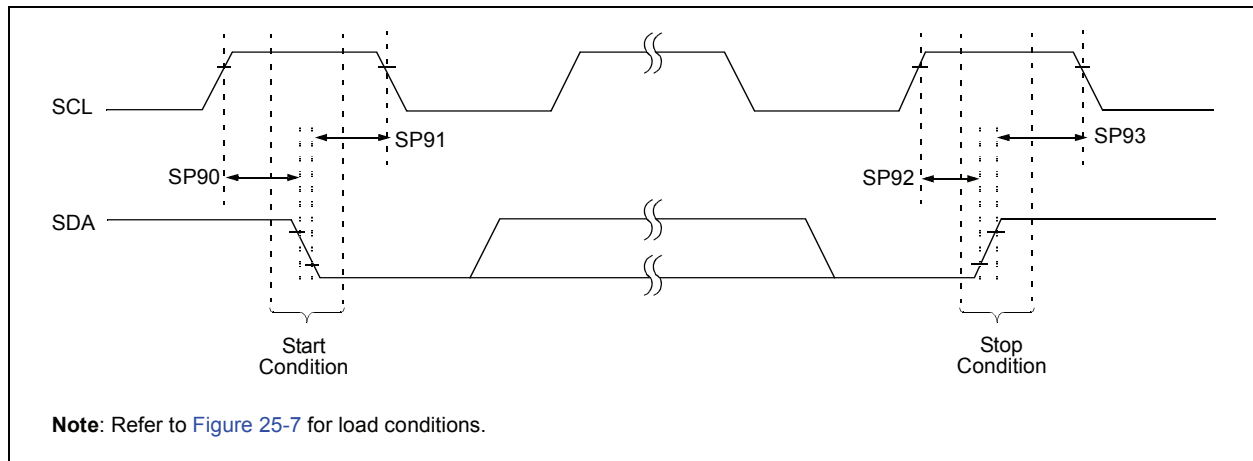
**TABLE 25-15: SPI MODE REQUIREMENTS**

Param No.	Symbol	Characteristic	Min.	Typ†	Max.	Units	Conditions
SP70*	TssL2sch, TssL2scL	$\overline{SS}\downarrow$ to SCK $\downarrow$ or SCK $\uparrow$ input	Tcy	—	—	ns	
SP71*	Tsch	SCK input high time (Slave mode)	Tcy + 20	—	—	ns	
SP72*	TscL	SCK input low time (Slave mode)	Tcy + 20	—	—	ns	
SP73*	TdIV2sch, TdIV2scL	Setup time of SDI data input to SCK edge	100	—	—	ns	
SP74*	Tsch2dIL, TscL2dIL	Hold time of SDI data input to SCK edge	100	—	—	ns	
SP75*	TdoR	SDO data output rise time	3.0-5.5V	—	10	25	ns
			1.8-5.5V	—	25	50	ns
SP76*	TdoF	SDO data output fall time	—	10	25	ns	
SP77*	TssH2doZ	$\overline{SS}\uparrow$ to SDO output high-impedance	10	—	50	ns	
SP78*	TscR	SCK output rise time (Master mode)	3.0-5.5V	—	10	25	ns
			1.8-5.5V	—	25	50	ns
SP79*	TscF	SCK output fall time (Master mode)	—	10	25	ns	
SP80*	Tsch2doV, TscL2doV	SDO data output valid after SCK edge	3.0-5.5V	—	—	50	ns
			1.8-5.5V	—	—	145	ns
SP81*	TdoV2sch, TdoV2scL	SDO data output setup to SCK edge	Tcy	—	—	ns	
SP82*	TssL2doV	SDO data output valid after $\overline{SS}\downarrow$ edge	—	—	50	ns	
SP83*	Tsch2ssh, TscL2ssh	$\overline{SS}\uparrow$ after SCK edge	1.5Tcy + 40	—	—	ns	

\* These parameters are characterized but not tested.

† Data in "Typ" column is at 3.0V, 25°C unless otherwise stated. These parameters are for design guidance only and are not tested.

**FIGURE 25-21: I<sup>2</sup>C™ BUS START/STOP BITS TIMING**



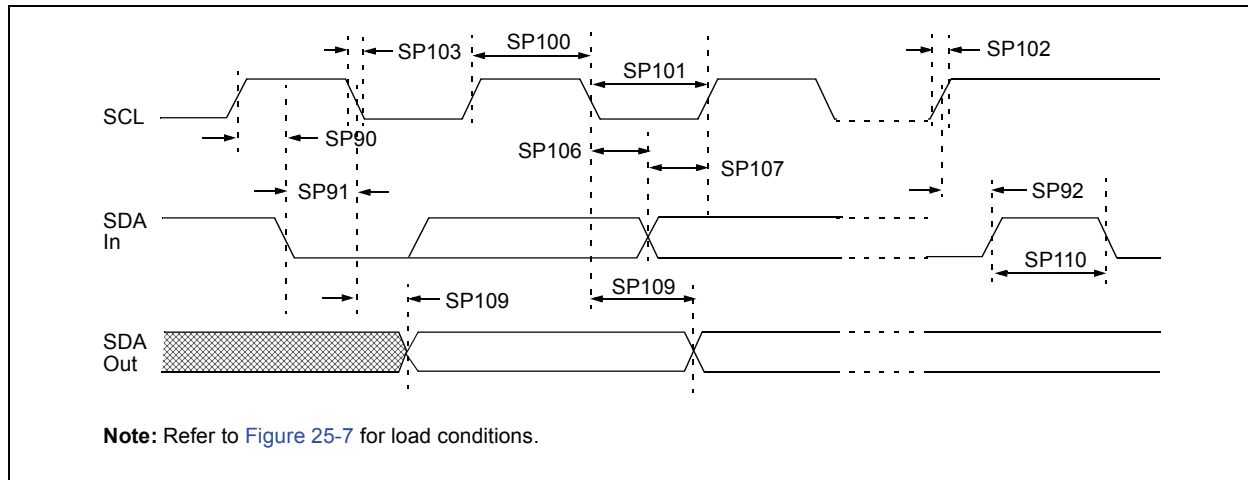
# PIC18(L)F1XK22

**TABLE 25-16: I<sup>2</sup>C™ BUS START/STOP BITS REQUIREMENTS**

Param No.	Symbol	Characteristic	Min.	Typ.	Max.	Units	Conditions	
SP90*	TSU:STA	Start condition	100 kHz mode	4700	—	—	ns	Only relevant for Repeated Start condition
		Setup time	400 kHz mode	600	—	—		
SP91*	THD:STA	Start condition	100 kHz mode	4000	—	—	ns	After this period, the first clock pulse is generated
		Hold time	400 kHz mode	600	—	—		
SP92*	TSU:STO	Stop condition	100 kHz mode	4700	—	—	ns	
		Setup time	400 kHz mode	600	—	—		
SP93	THD:STO	Stop condition	100 kHz mode	4000	—	—	ns	
		Hold time	400 kHz mode	600	—	—		

\* These parameters are characterized but not tested.

**FIGURE 25-22: I<sup>2</sup>C™ BUS DATA TIMING**





**TABLE 25-17: I<sup>2</sup>C™ BUS DATA REQUIREMENTS**

Param. No.	Symbol	Characteristic		Min.	Max.	Units	Conditions
SP100*	THIGH	Clock high time	100 kHz mode	4.0	—	μs	Device must operate at a minimum of 1.5 MHz
			400 kHz mode	0.6	—	μs	Device must operate at a minimum of 10 MHz
			SSP Module	1.5T <sub>CY</sub>	—		
SP101*	TLOW	Clock low time	100 kHz mode	4.7	—	μs	Device must operate at a minimum of 1.5 MHz
			400 kHz mode	1.3	—	μs	Device must operate at a minimum of 10 MHz
			SSP Module	1.5T <sub>CY</sub>	—		
SP102*	TR	SDA and SCL rise time	100 kHz mode	—	1000	ns	
			400 kHz mode	20 + 0.1C <sub>B</sub>	300	ns	C <sub>B</sub> is specified to be from 10-400 pF
SP103*	TF	SDA and SCL fall time	100 kHz mode	—	250	ns	
			400 kHz mode	20 + 0.1C <sub>B</sub>	250	ns	C <sub>B</sub> is specified to be from 10-400 pF
SP90*	TSU:STA	Start condition setup time	100 kHz mode	4.7	—	μs	Only relevant for Repeated Start condition
			400 kHz mode	0.6	—	μs	
SP91*	THD:STA	Start condition hold time	100 kHz mode	4.0	—	μs	After this period the first clock pulse is generated
			400 kHz mode	0.6	—	μs	
SP106*	THD:DAT	Data input hold time	100 kHz mode	0	—	ns	
			400 kHz mode	0	0.9	μs	
SP107*	TSU:DAT	Data input setup time	100 kHz mode	250	—	ns	<b>(Note 2)</b>
			400 kHz mode	100	—	ns	
SP92*	TSU:STO	Stop condition setup time	100 kHz mode	4.7	—	μs	
			400 kHz mode	0.6	—	μs	
SP109*	TAA	Output valid from clock	100 kHz mode	—	3500	ns	<b>(Note 1)</b>
			400 kHz mode	—	—	ns	
SP110*	TBUF	Bus free time	100 kHz mode	4.7	—	μs	Time the bus must be free before a new transmission can start
			400 kHz mode	1.3	—	μs	
SP	C <sub>B</sub>	Bus capacitive loading		—	400	pF	

\* These parameters are characterized but not tested.

**Note 1:** As a transmitter, the device must provide this internal minimum delay time to bridge the undefined region (min. 300 ns) of the falling edge of SCL to avoid unintended generation of Start or Stop conditions.

**2:** A Fast mode (400 kHz) I<sup>2</sup>C™ bus device can be used in a Standard mode (100 kHz) I<sup>2</sup>C bus system, but the requirement TSU:DAT ≥ 250 ns must then be met. This will automatically be the case if the device does not stretch the low period of the SCL signal. If such a device does stretch the low period of the SCL signal, it must output the next data bit to the SDA line TR max. + TSU:DAT = 1000 + 250 = 1250 ns (according to the Standard mode I<sup>2</sup>C bus specification), before the SCL line is released.

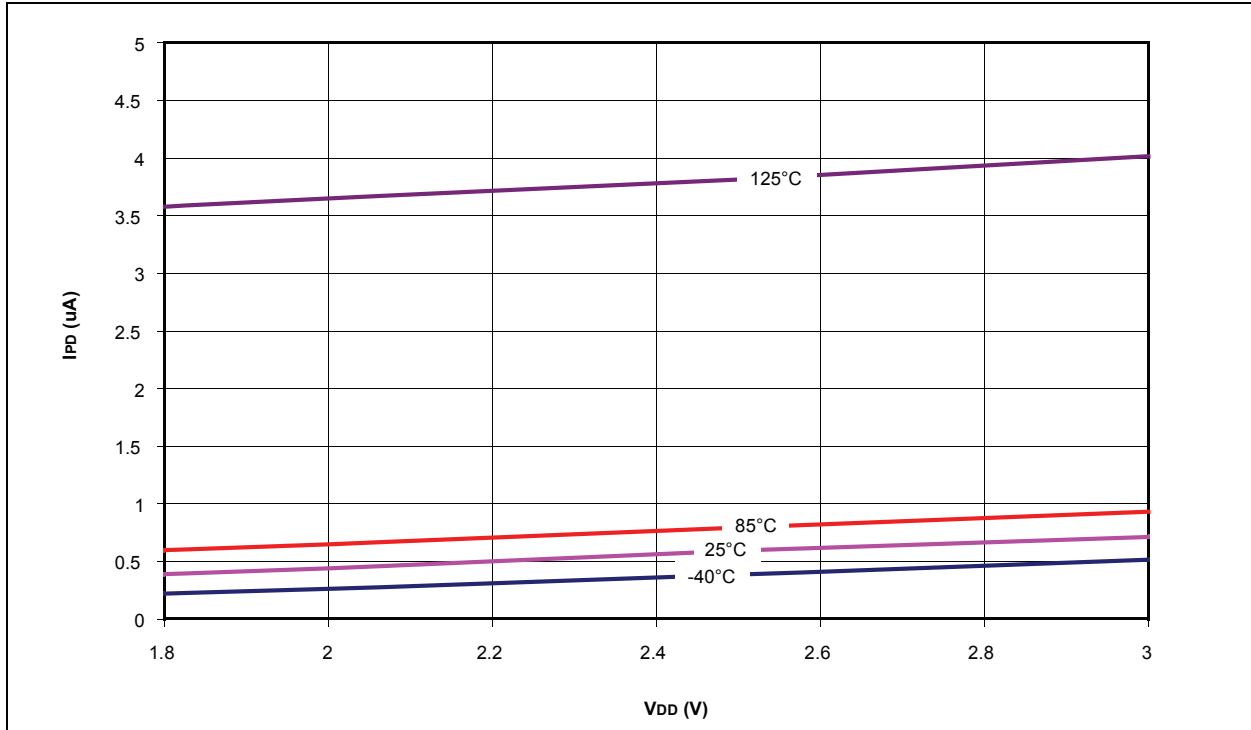
# PIC18(L)F1XK22

---

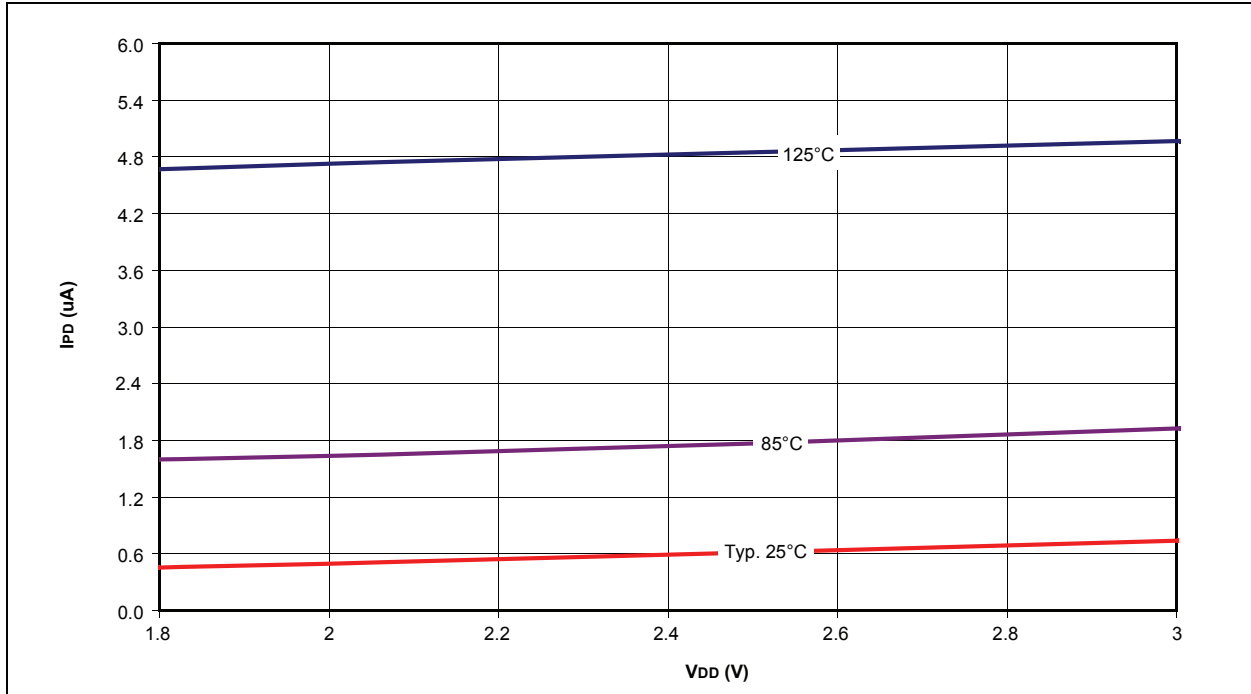
NOTES:

## 26.0 DC AND AC CHARACTERISTICS GRAPHS AND CHARTS

**FIGURE 26-1: PIC18LF1XK22 TYPICAL BASE IPD**



**FIGURE 26-2: PIC18LF1XK22 TYPICAL IPD FOR WATCHDOG TIMER**



# PIC18(L)F1XK22

FIGURE 26-3: PIC18LF1XK22 TYPICAL  $I_{PD}$  FOR BROWN-OUT RESET

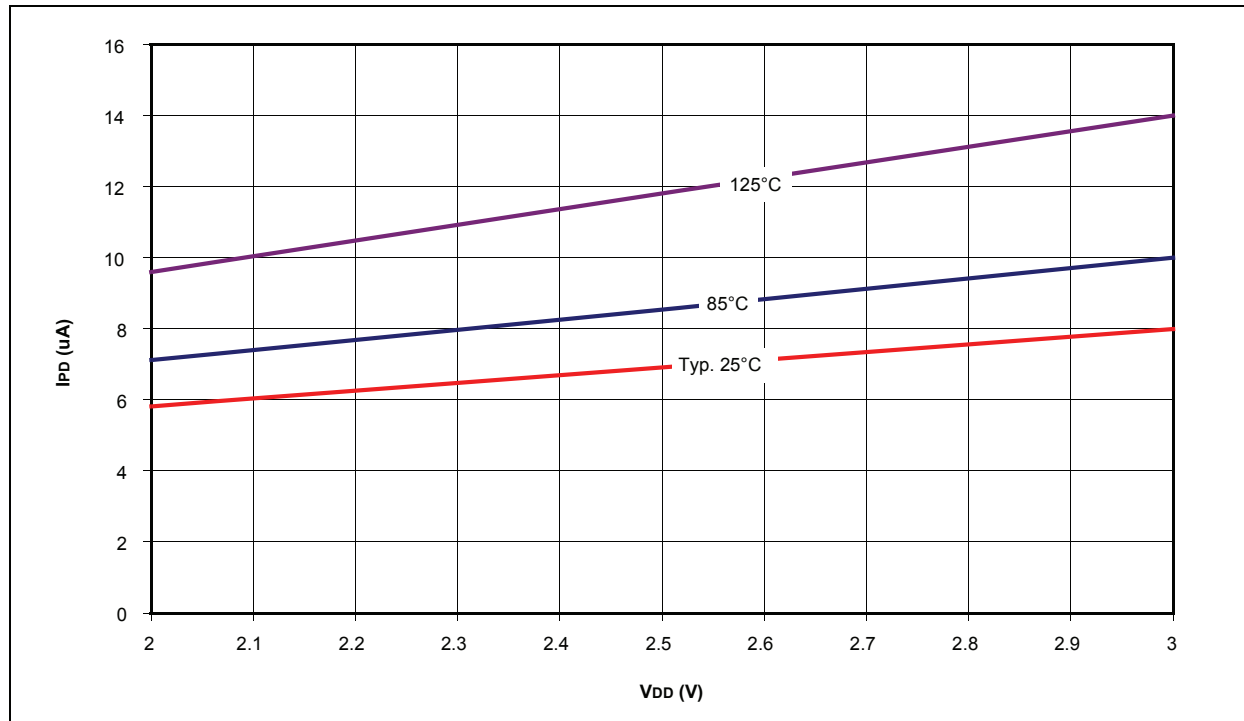
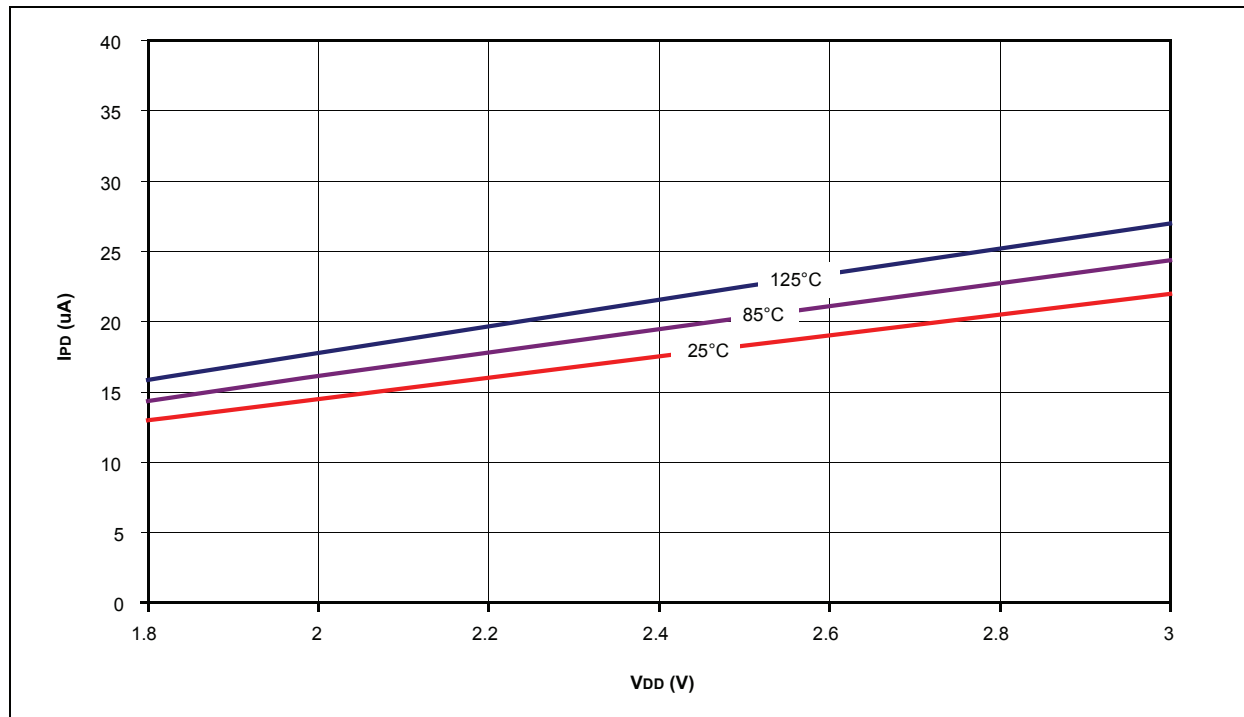
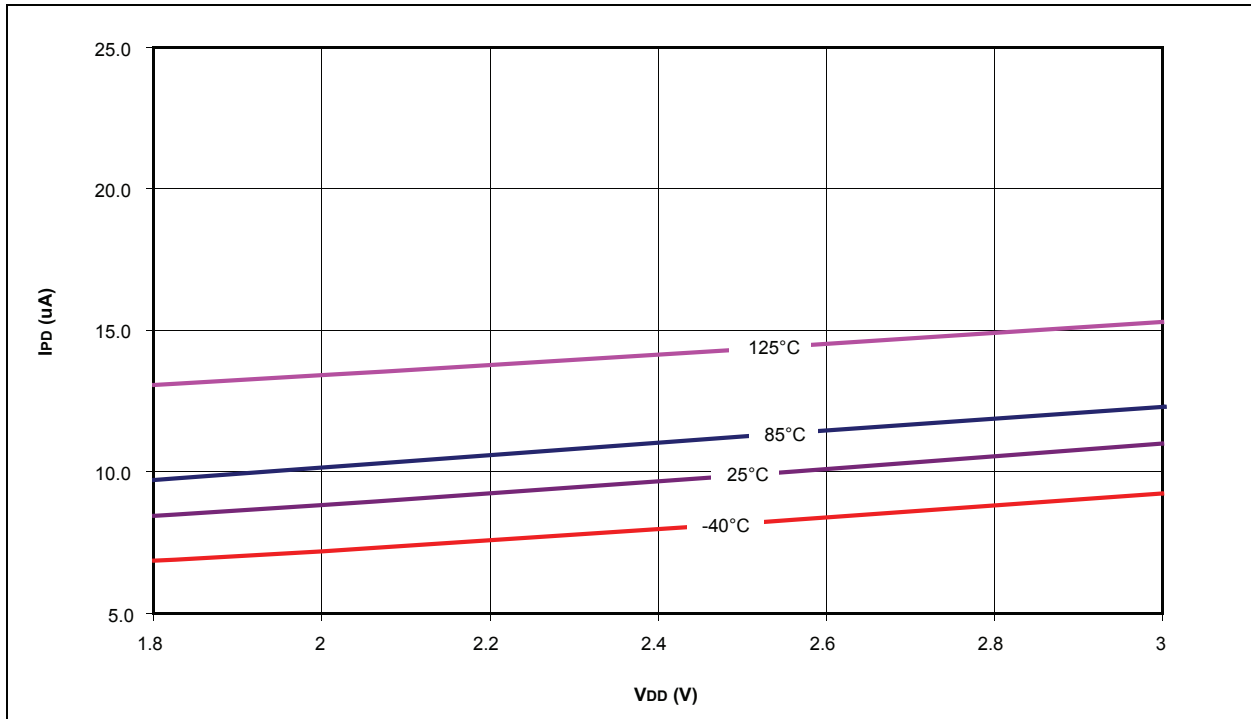


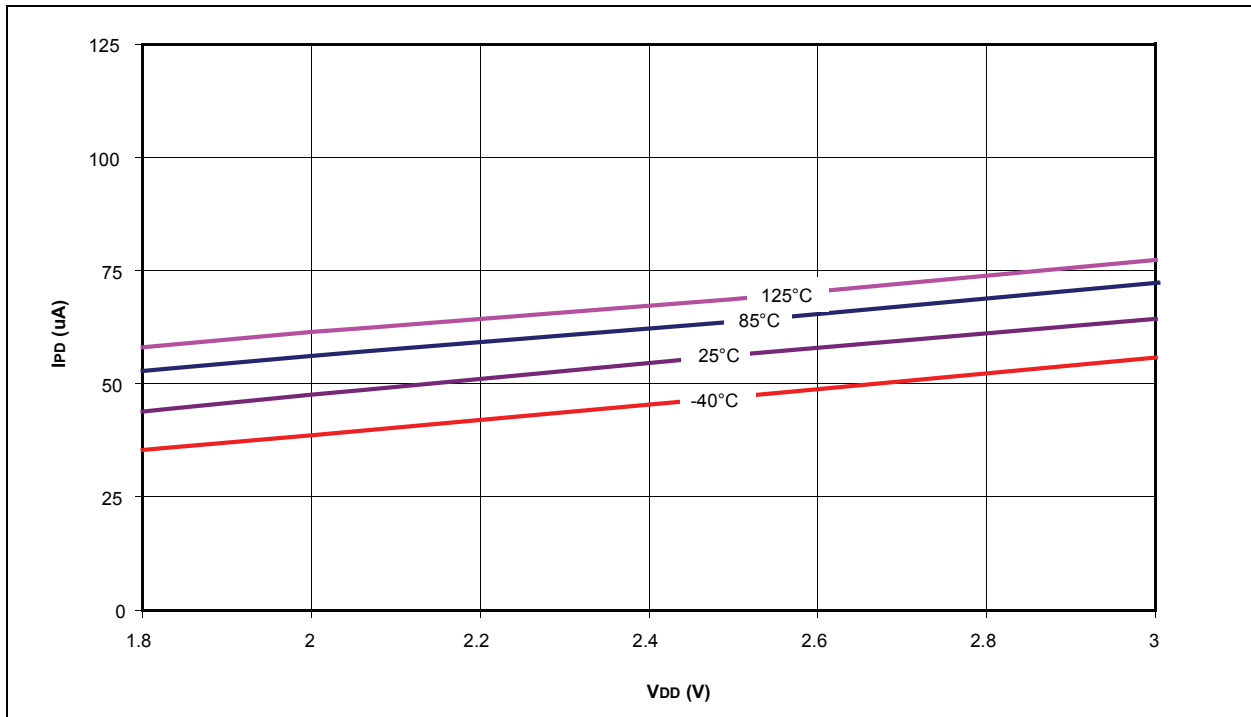
FIGURE 26-4: PIC18LF1XK22 TYPICAL  $I_{PD}$  FOR COMPARATOR VOLTAGE REFERENCE



**FIGURE 26-5: PIC18LF1XK22 I<sub>COMP</sub> – TYPICAL I<sub>PD</sub> FOR COMPARATOR IN LOW-POWER MODE**



**FIGURE 26-6: PIC18LF1XK22 I<sub>COMP</sub> – TYPICAL I<sub>PD</sub> FOR COMPARATOR IN HIGH-POWER MODE**



# PIC18(L)F1XK22

FIGURE 26-7: PIC18LF1XK22 TYPICAL RC\_RUN 31 kHz I<sub>DD</sub>

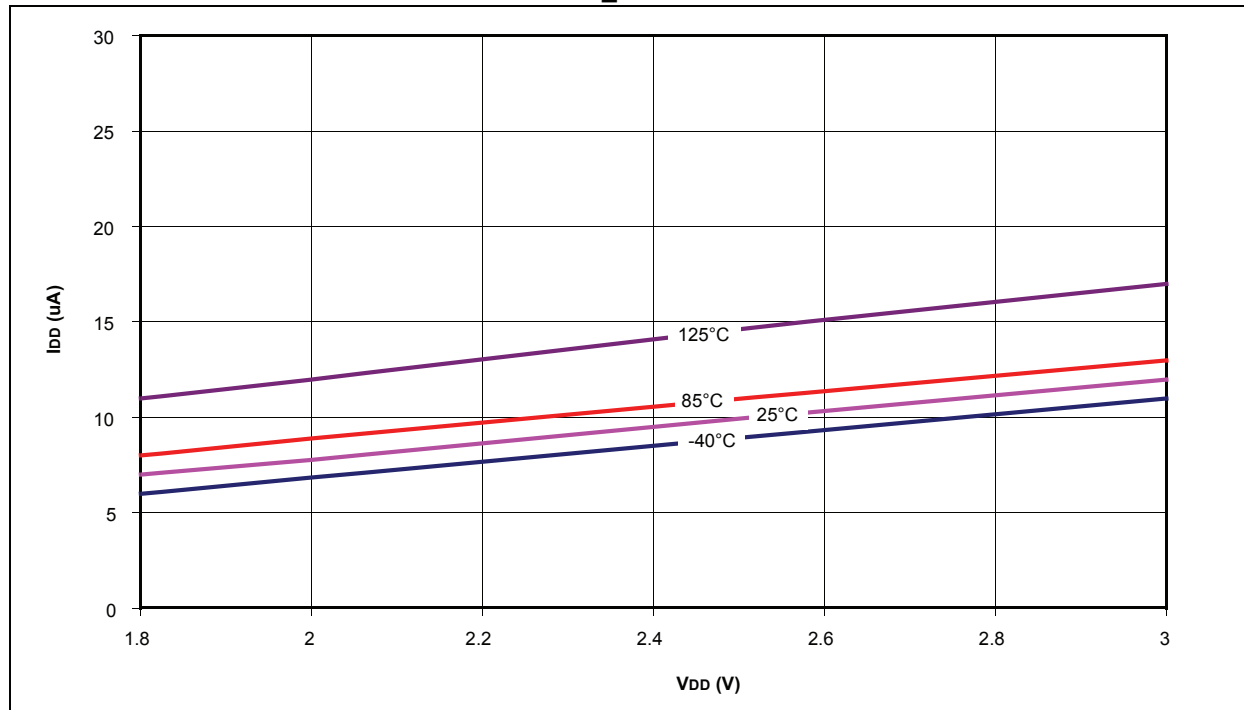
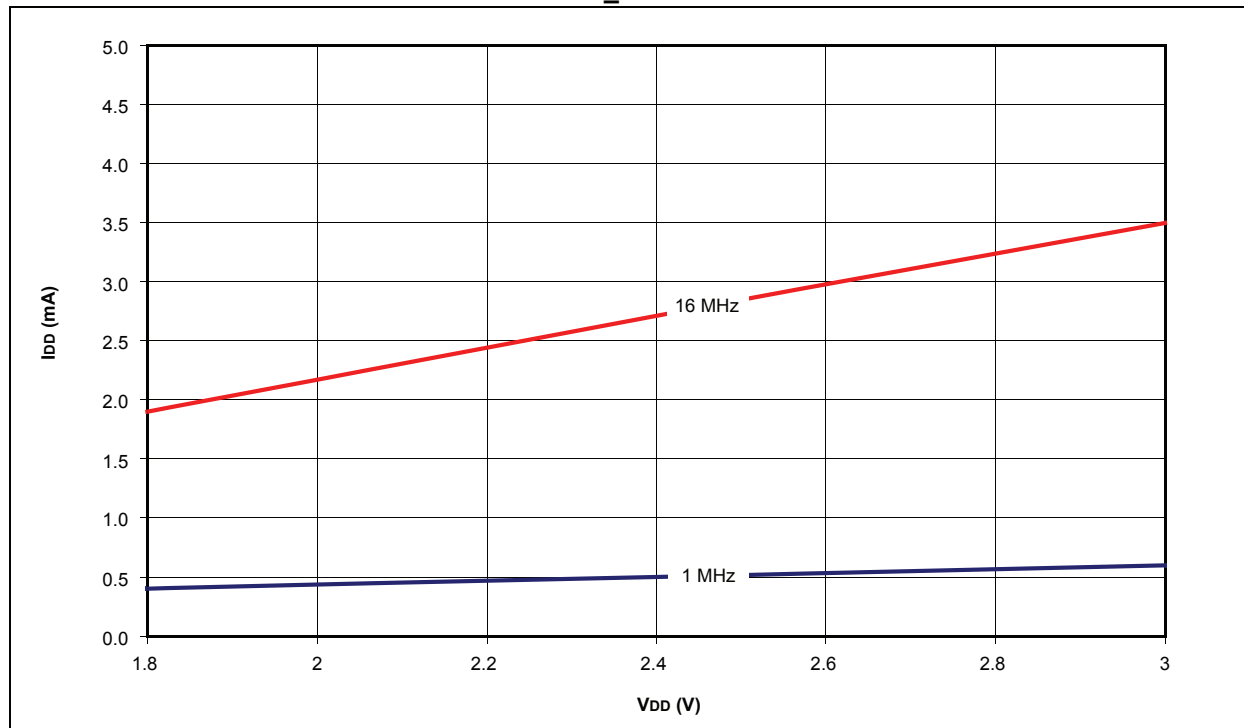
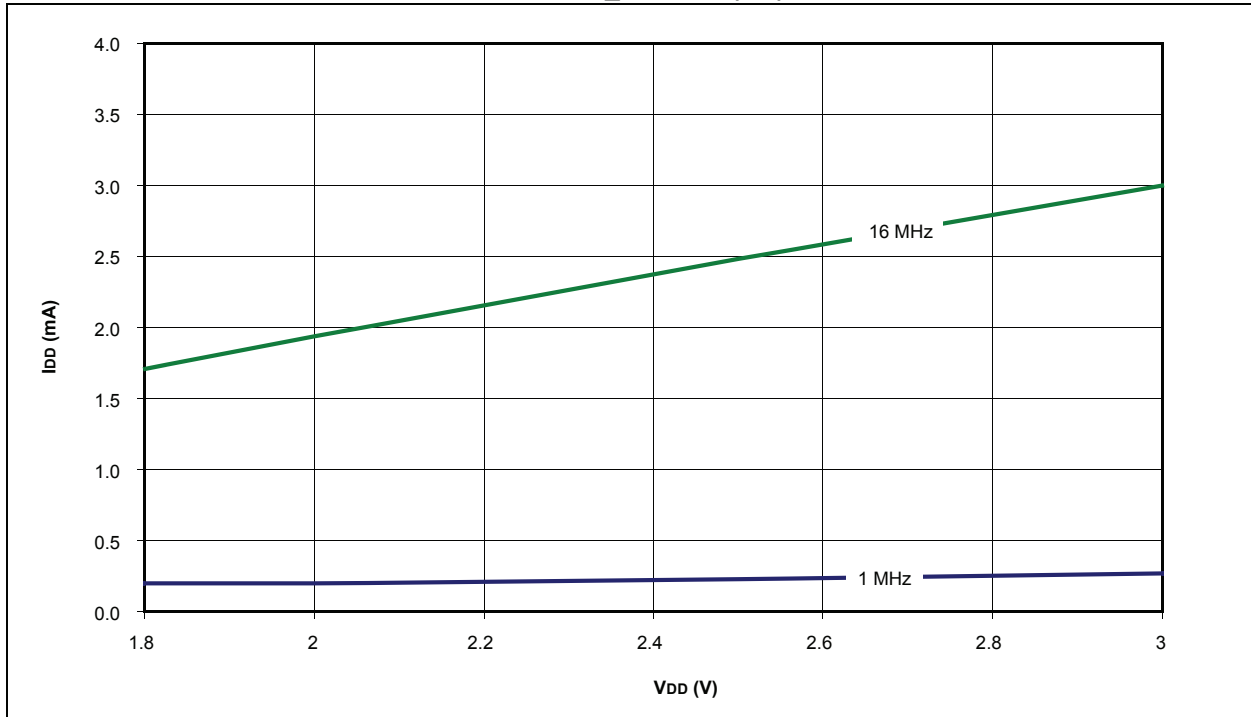


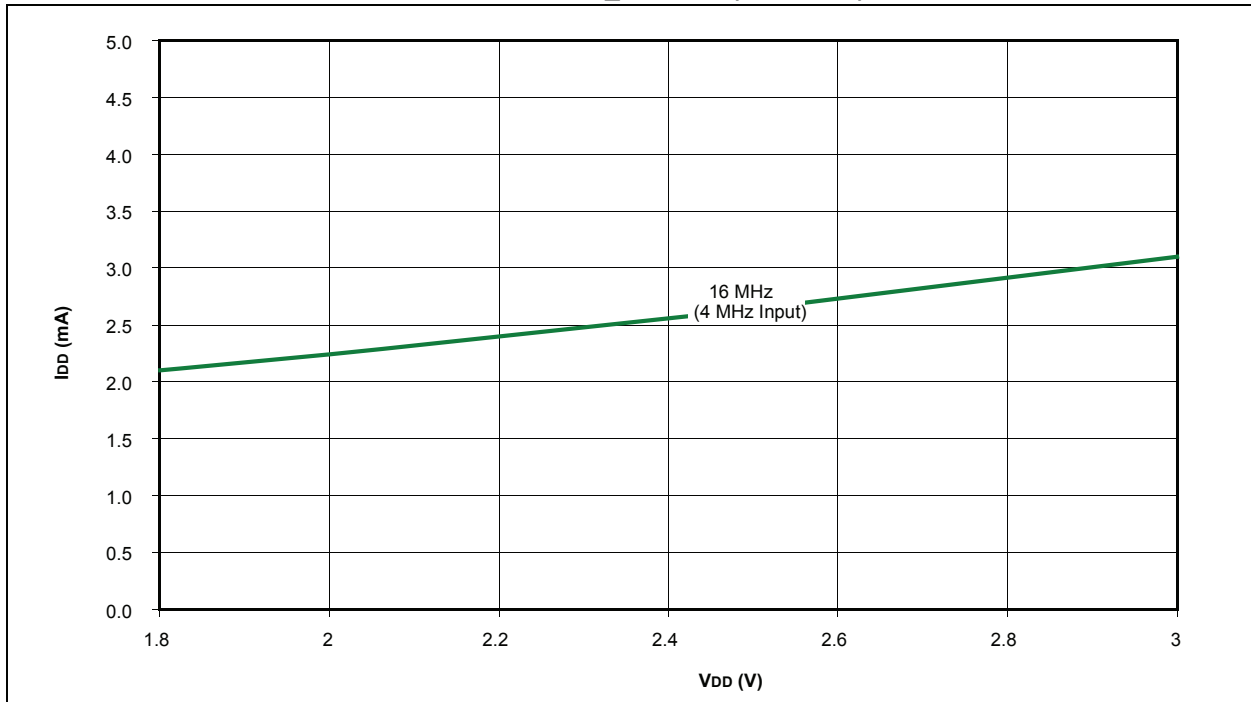
FIGURE 26-8: PIC18LF1XK22 TYPICAL RC\_RUN I<sub>DD</sub>



**FIGURE 26-9: PIC18LF1XK22 TYPICAL PRI\_RUN I<sub>DD</sub> (EC)**



**FIGURE 26-10: PIC18LF1XK22 TYPICAL PRI\_RUN I<sub>DD</sub> (HS + PLL)**



# PIC18(L)F1XK22

FIGURE 26-11: PIC18F1XK22 TYPICAL BASE I<sub>PD</sub>

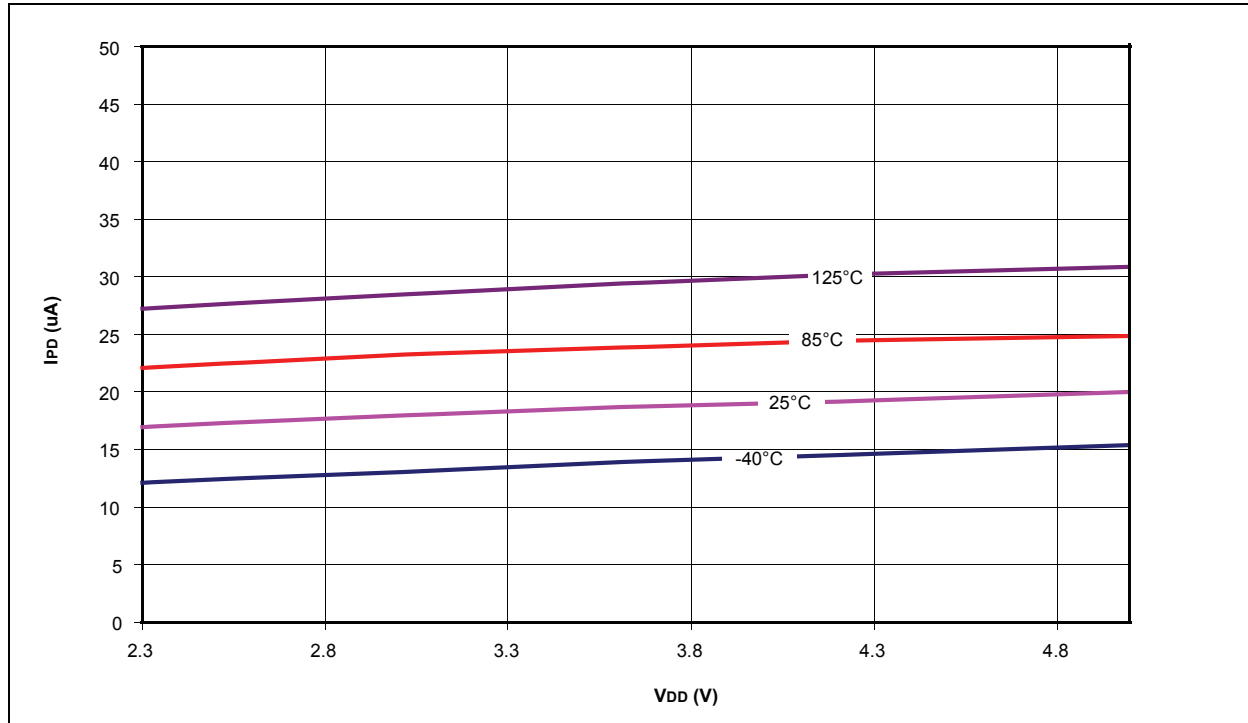
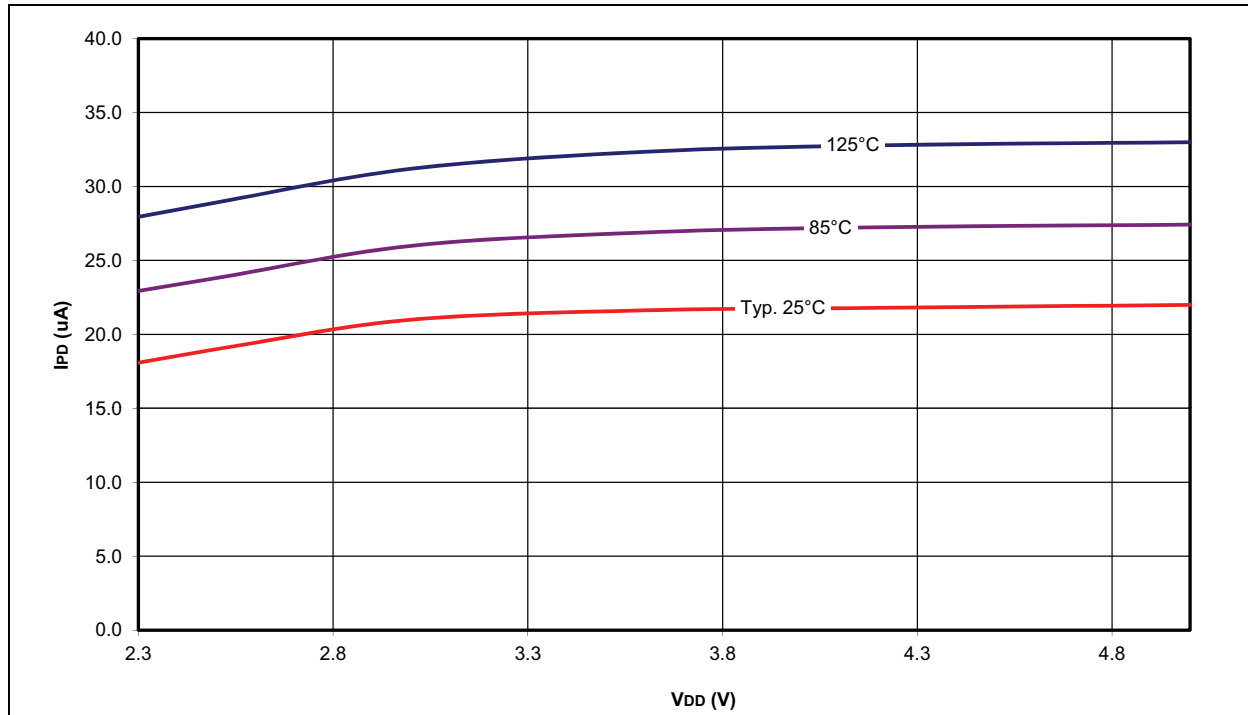
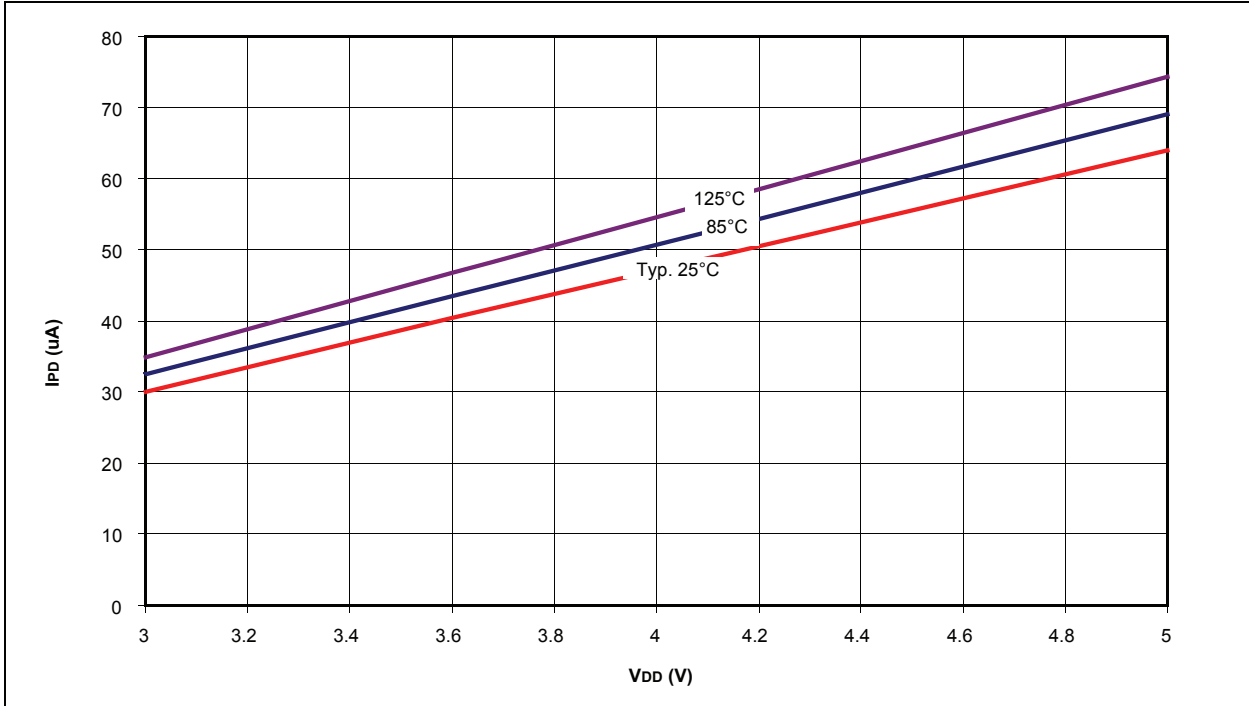


FIGURE 26-12: PIC18F1XK22 TYPICAL I<sub>PD</sub> FOR WATCHDOG TIMER

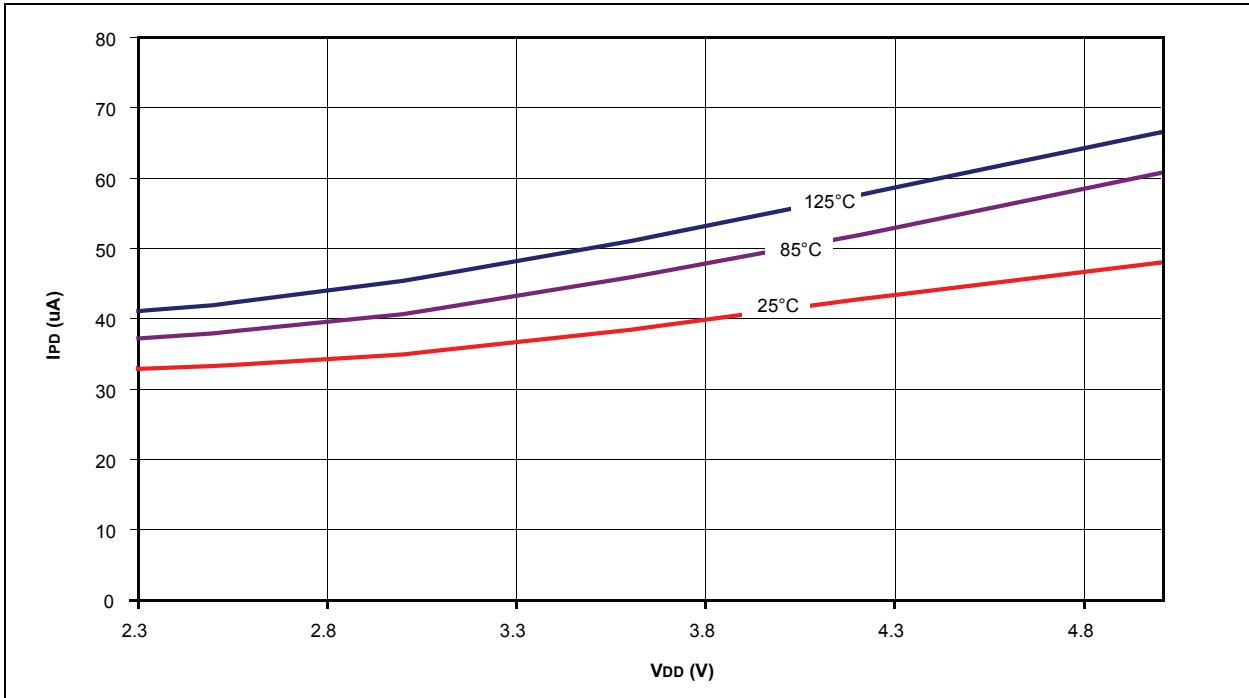




**FIGURE 26-13: PIC18F1XK22 TYPICAL I<sub>PD</sub> FOR BROWN-OUT RESET**



**FIGURE 26-14: PIC18F1XK22 TYPICAL I<sub>PD</sub> FOR COMPARATOR VOLTAGE REFERENCE**



# PIC18(L)F1XK22

FIGURE 26-15: PIC18F1XK22 I<sub>COMP</sub> – TYPICAL I<sub>PD</sub> FOR COMPARATOR IN LOW-POWER MODE

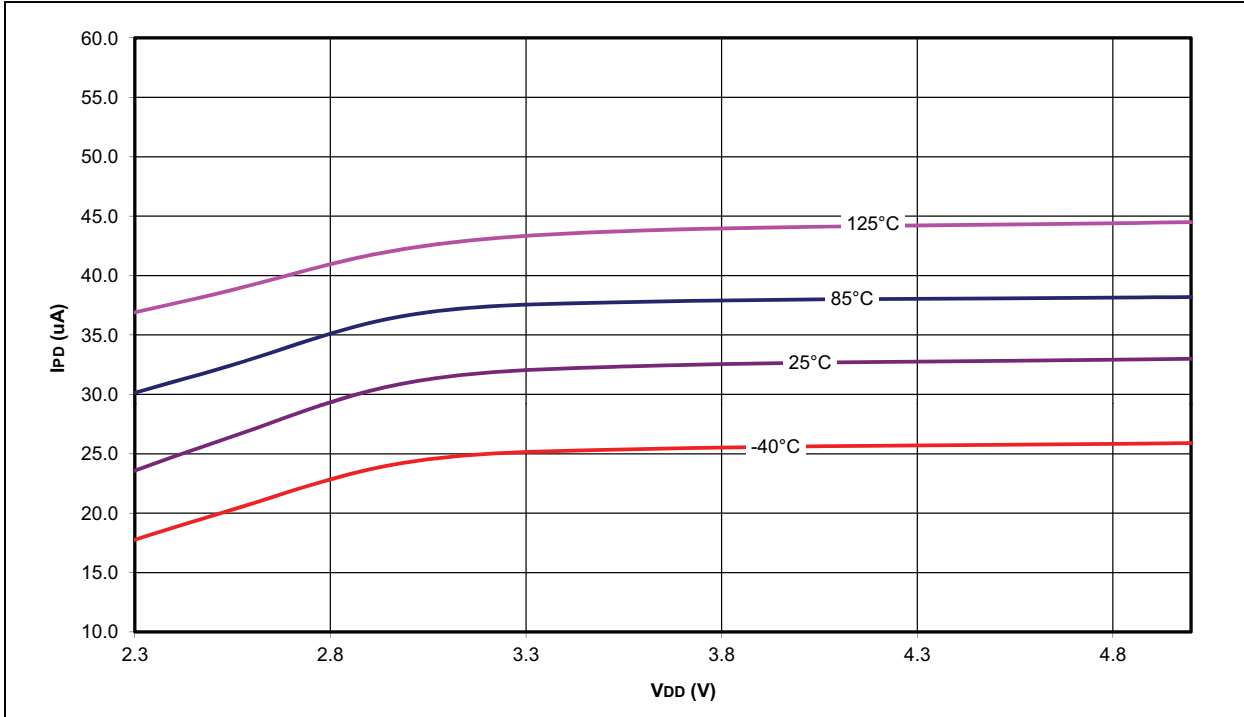


FIGURE 26-16: PIC18F1XK22 I<sub>COMP</sub> – TYPICAL I<sub>PD</sub> FOR COMPARATOR IN HIGH-POWER MODE

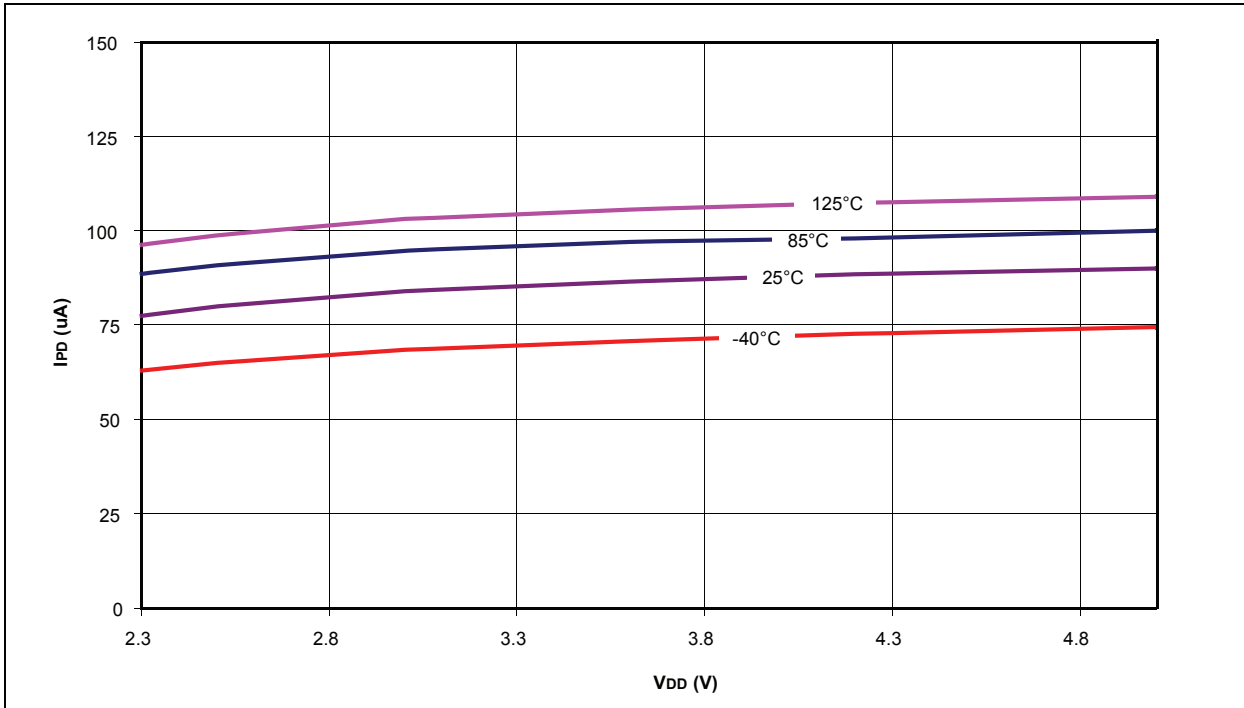


FIGURE 26-17: PIC18F1XK22 TYPICAL RC\_RUN 31 kHz I<sub>DD</sub>

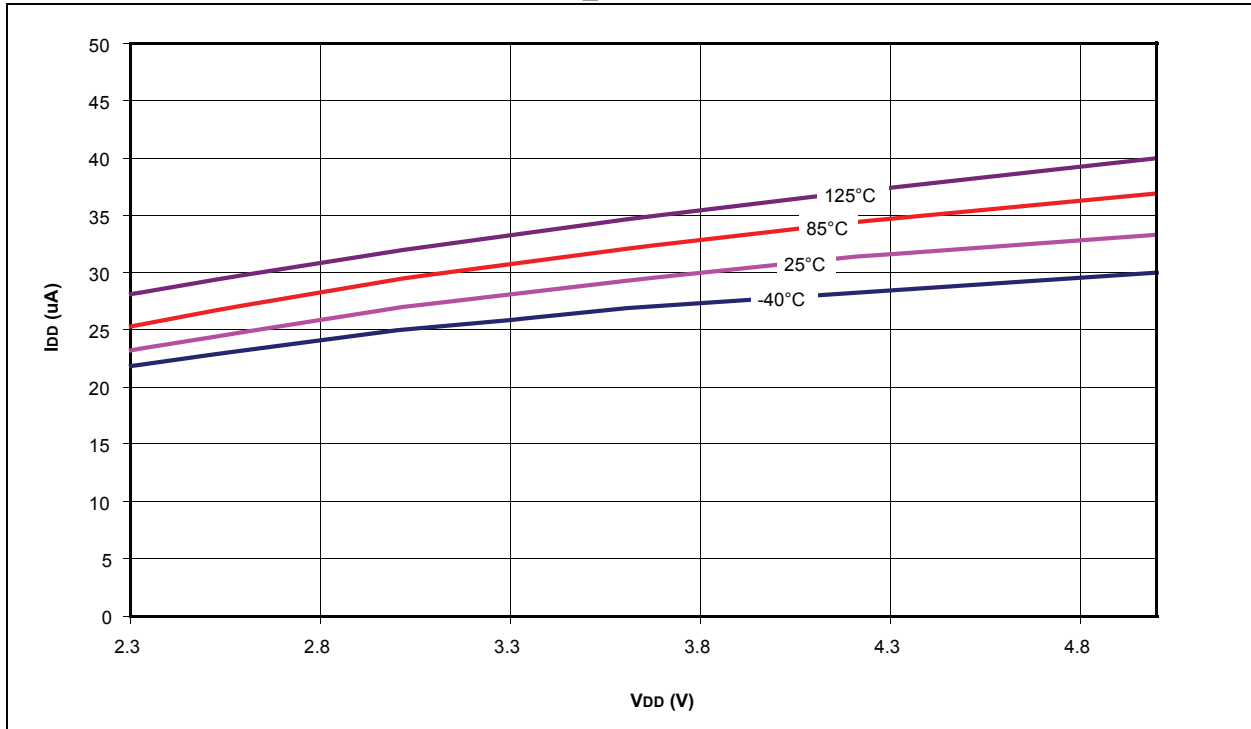
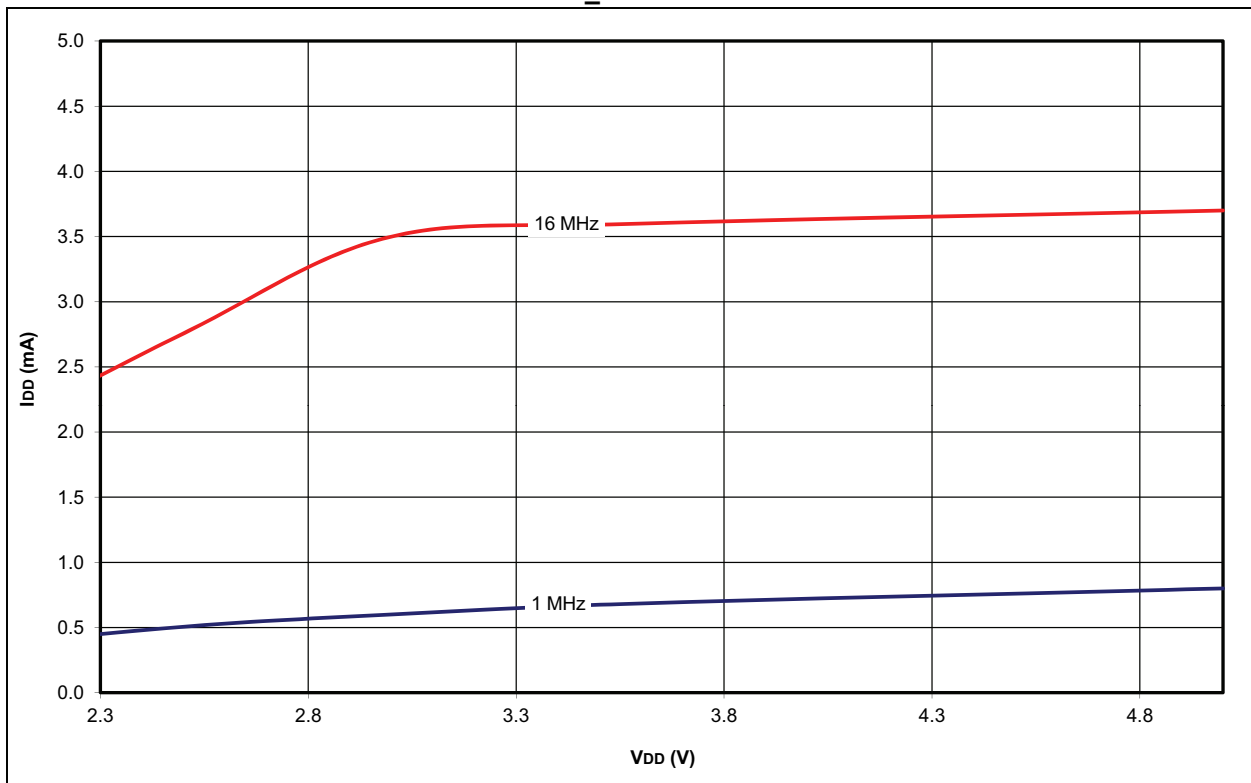


FIGURE 26-18: PIC18F1XK22 TYPICAL RC\_RUN I<sub>DD</sub>



# PIC18(L)F1XK22

FIGURE 26-19: PIC18F1XK22 TYPICAL PRI\_RUN I<sub>DD</sub> (EC)

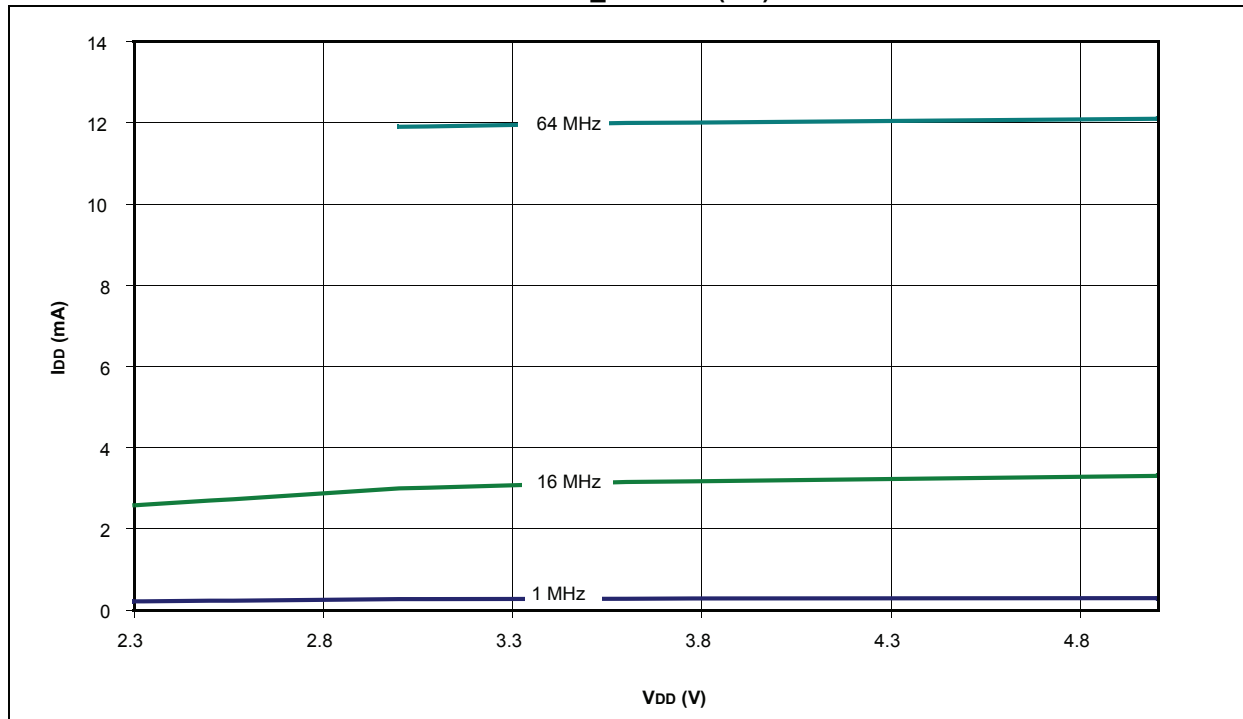
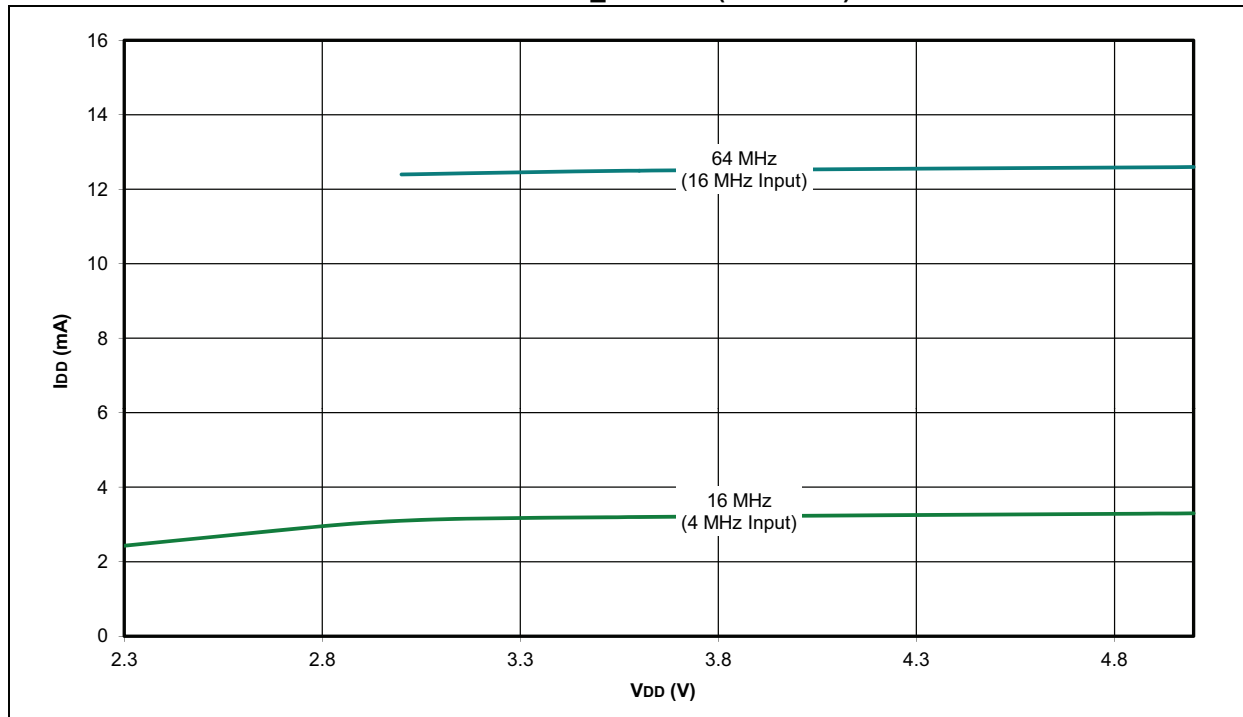
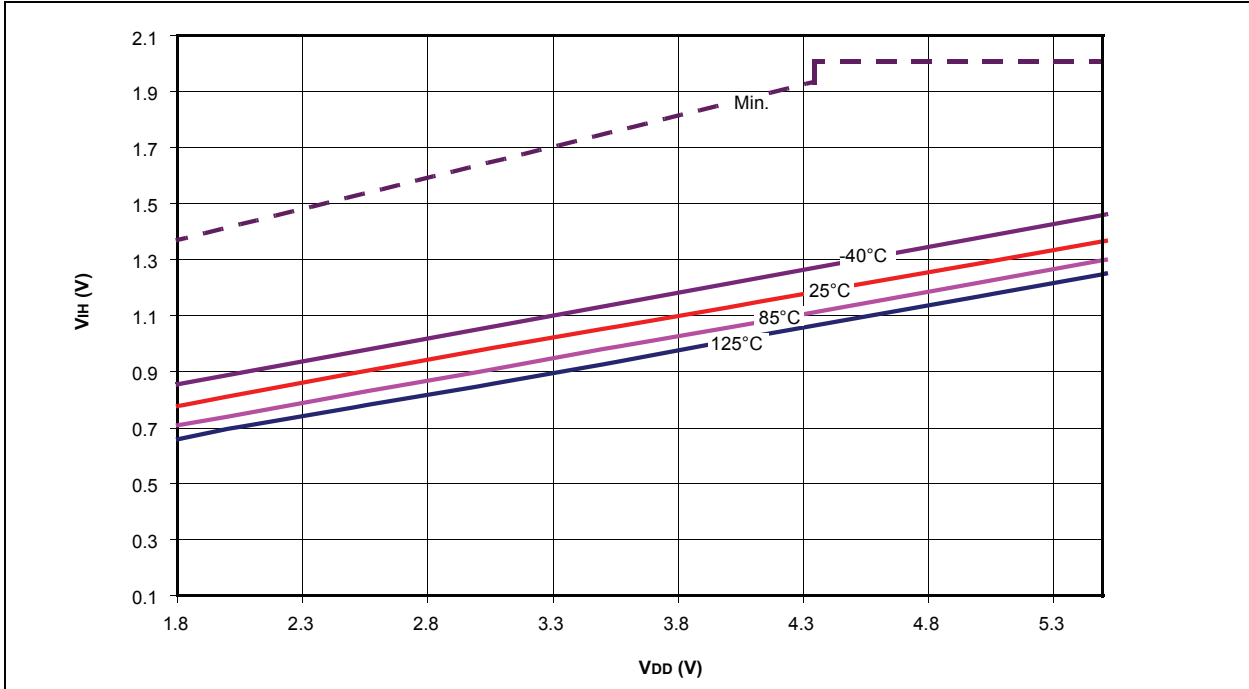


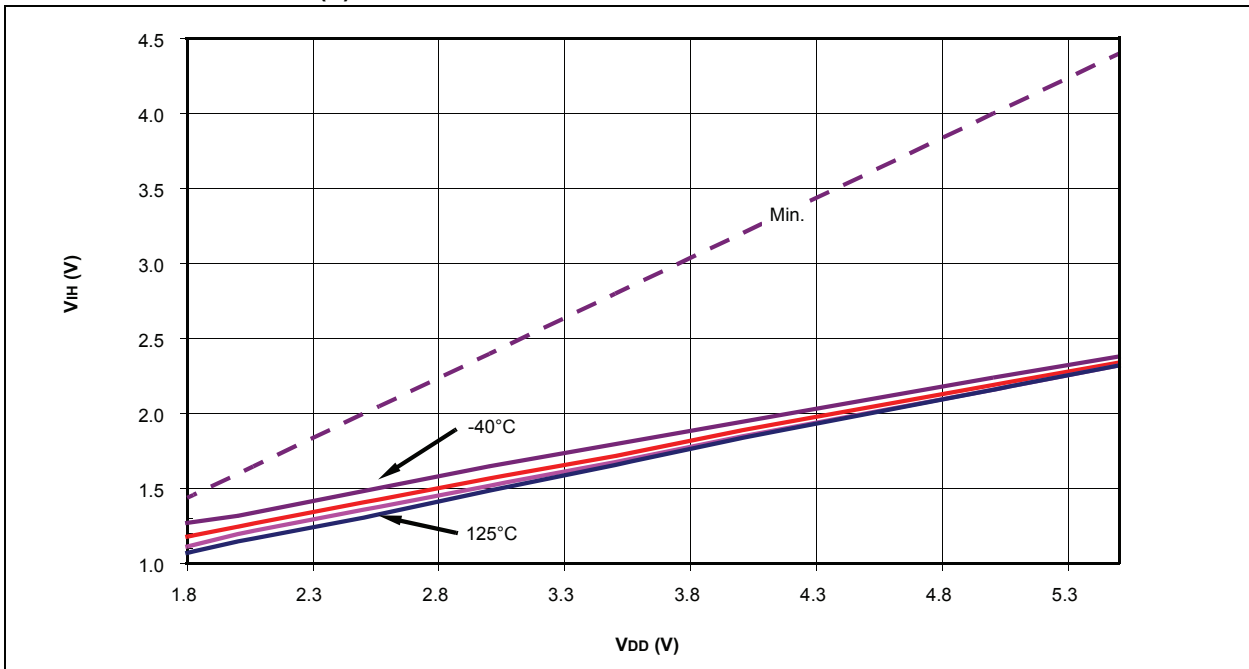
FIGURE 26-20: PIC18F1XK22 TYPICAL PRI\_RUN I<sub>DD</sub> (HS + PLL)



**FIGURE 26-21: PIC18(L)F1XK22 TTL BUFFER TYPICAL  $V_{IH}$**



**FIGURE 26-22: PIC18(L)F1XK22 SCHMITT TRIGGER BUFFER TYPICAL  $V_{IH}$**



# PIC18(L)F1XK22

FIGURE 26-23: PIC18(L)F1XK22 TTL BUFFER TYPICAL  $V_{IL}$

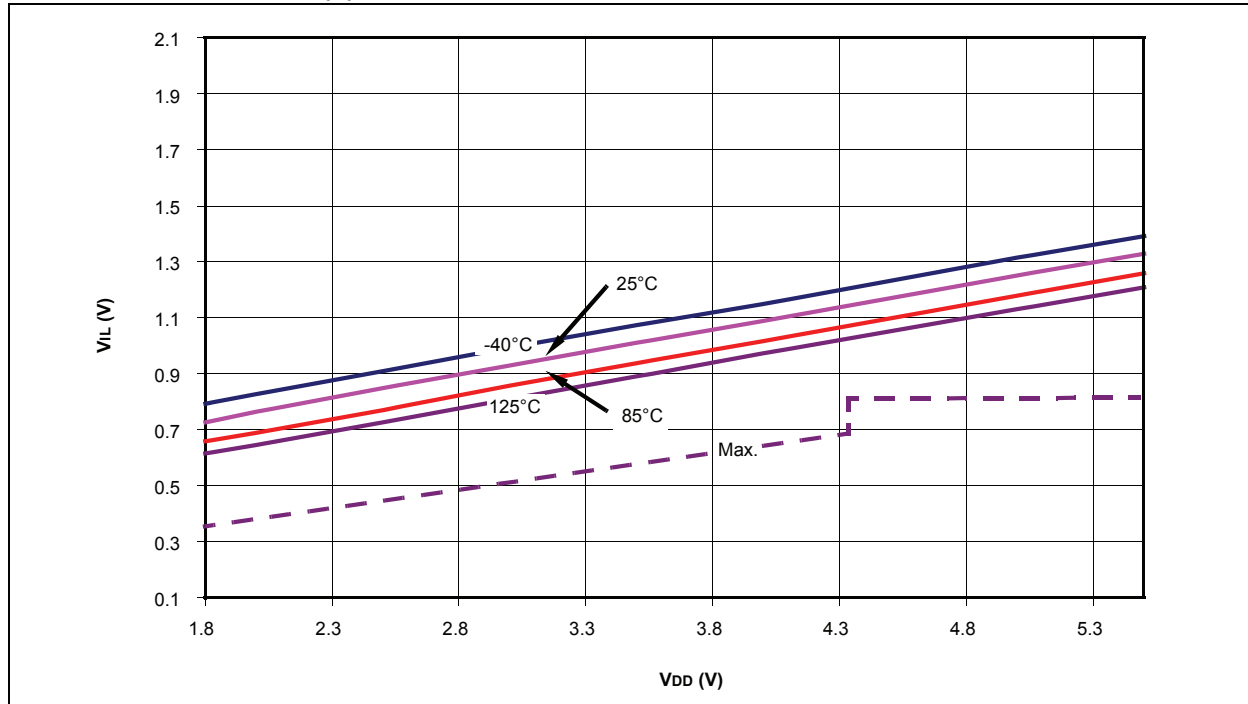
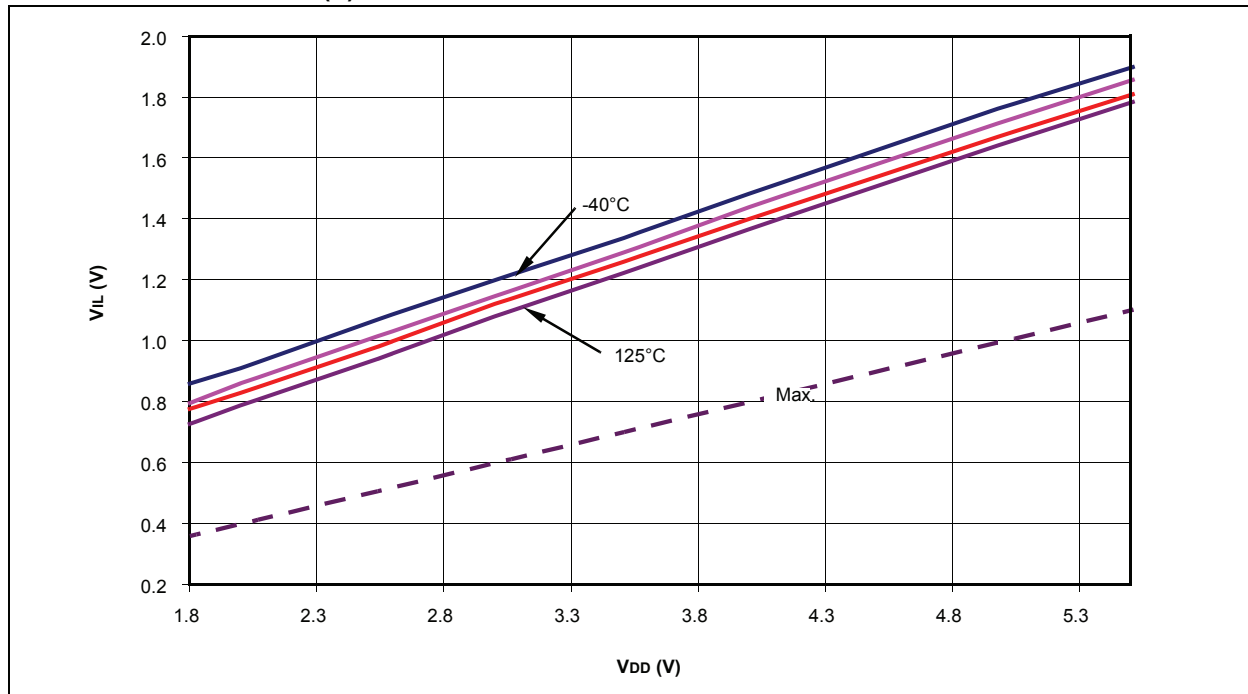


FIGURE 26-24: PIC18(L)F1XK22 SCHMITT BUFFER TYPICAL  $V_{IL}$



# PIC18(L)F1XK22

FIGURE 26-25: PIC18F1XK22 TYPICAL LF-INTOSC FREQUENCY (MAX./MIN. = 31.25 kHz  $\pm$  15%)

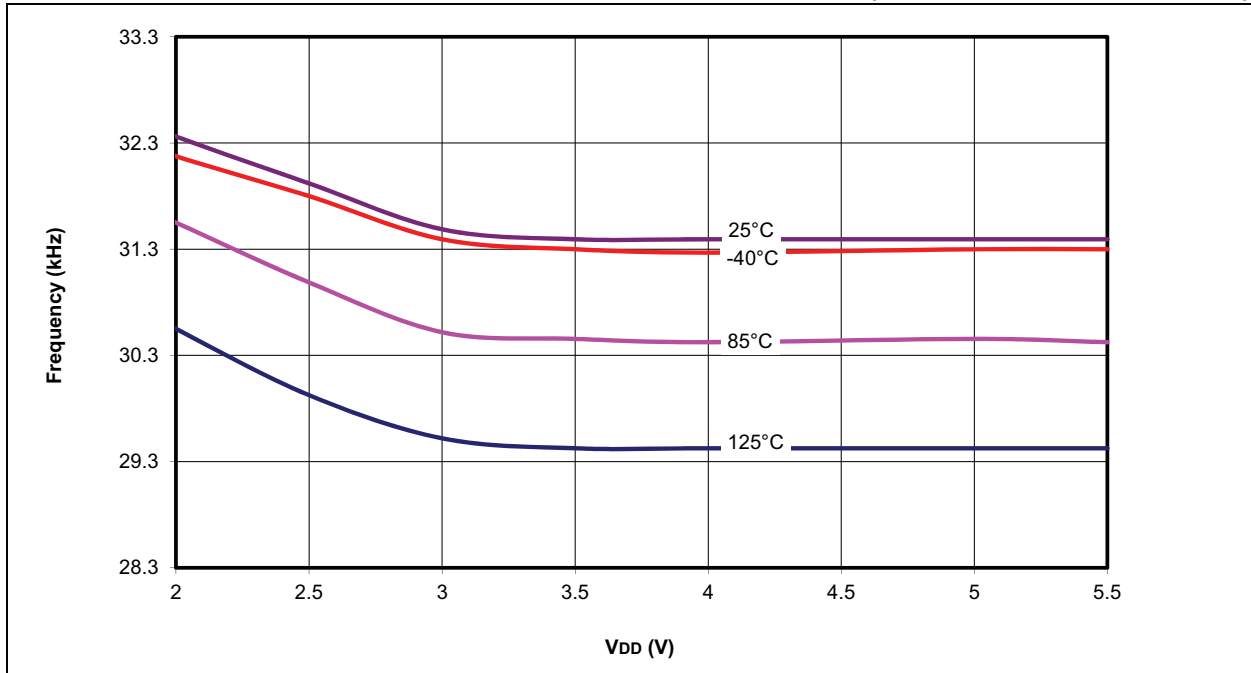
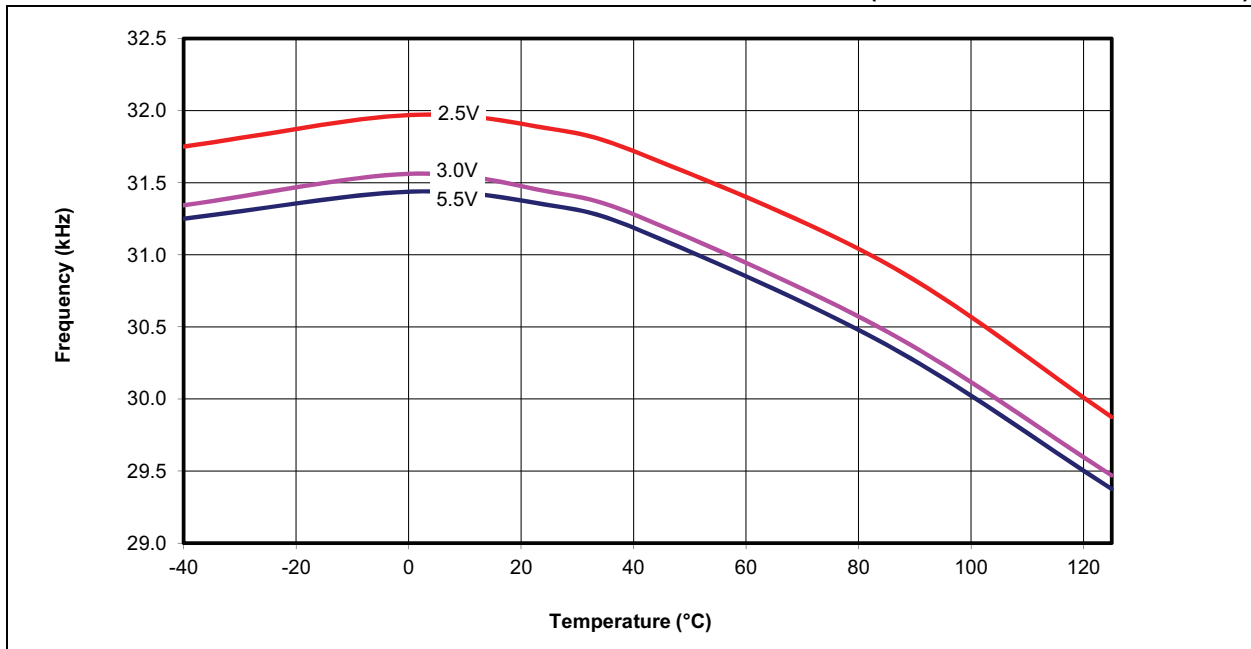
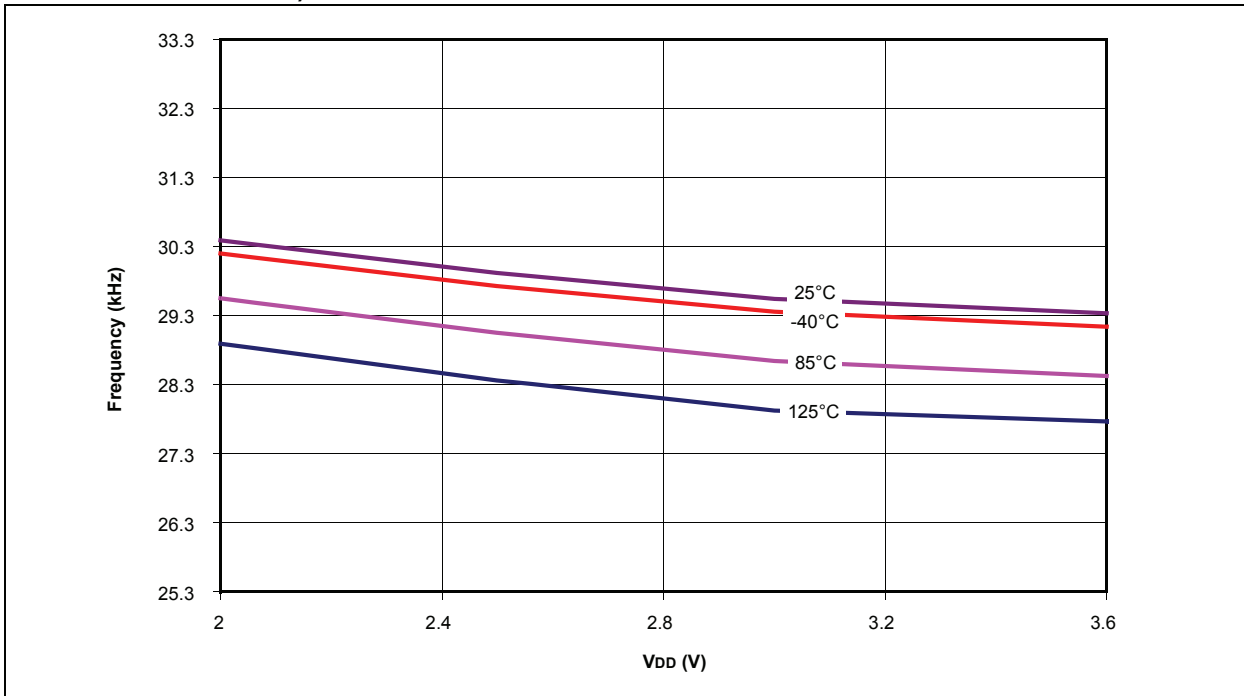


FIGURE 26-26: PIC18F1XK22 TYPICAL LF-INTOSC FREQUENCY (MAX./MIN. = 31.25 kHz  $\pm$  15%)



# PIC18(L)F1XK22

**FIGURE 26-27: PIC18LF1XK22 TYPICAL LF-INTOSC FREQUENCY (MAX./MIN. = 31.25 kHz  $\pm$  15%)**



**FIGURE 26-28: PIC18LF1XK22 TYPICAL LF-INTOSC FREQUENCY (MAX./MIN. = 31.25 kHz  $\pm$  15%)**

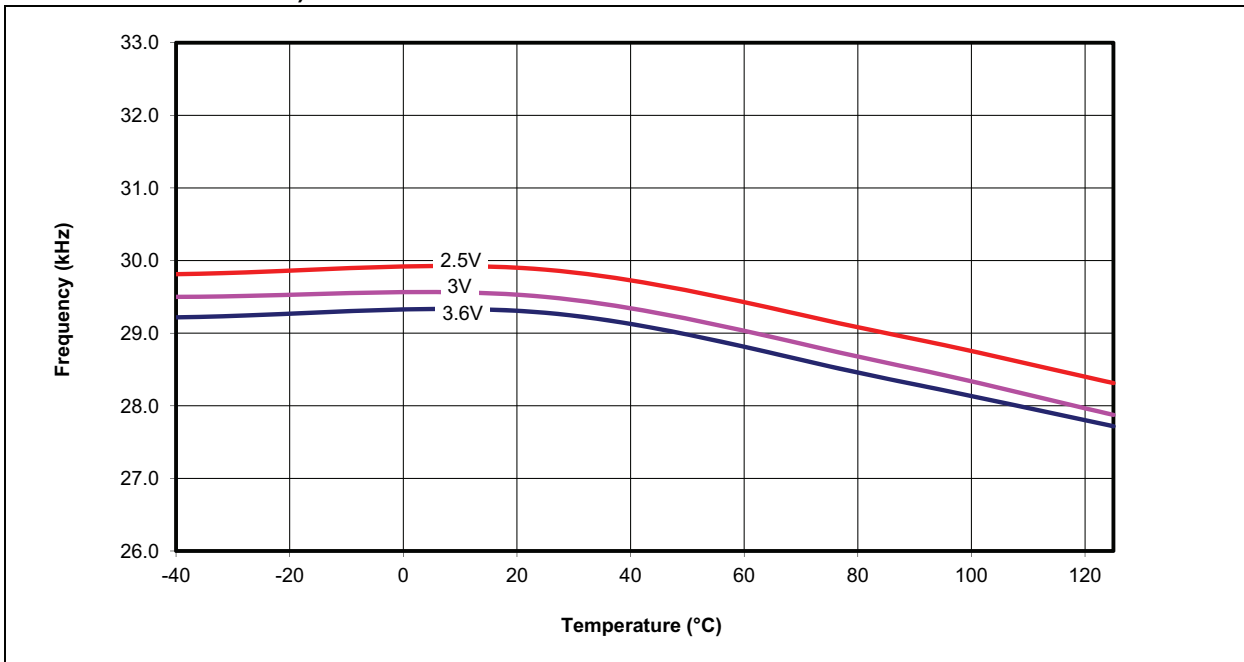




FIGURE 26-29: PIC18F1XK22 TYPICAL  $V_{OH}$  vs.  $I_{OH}$

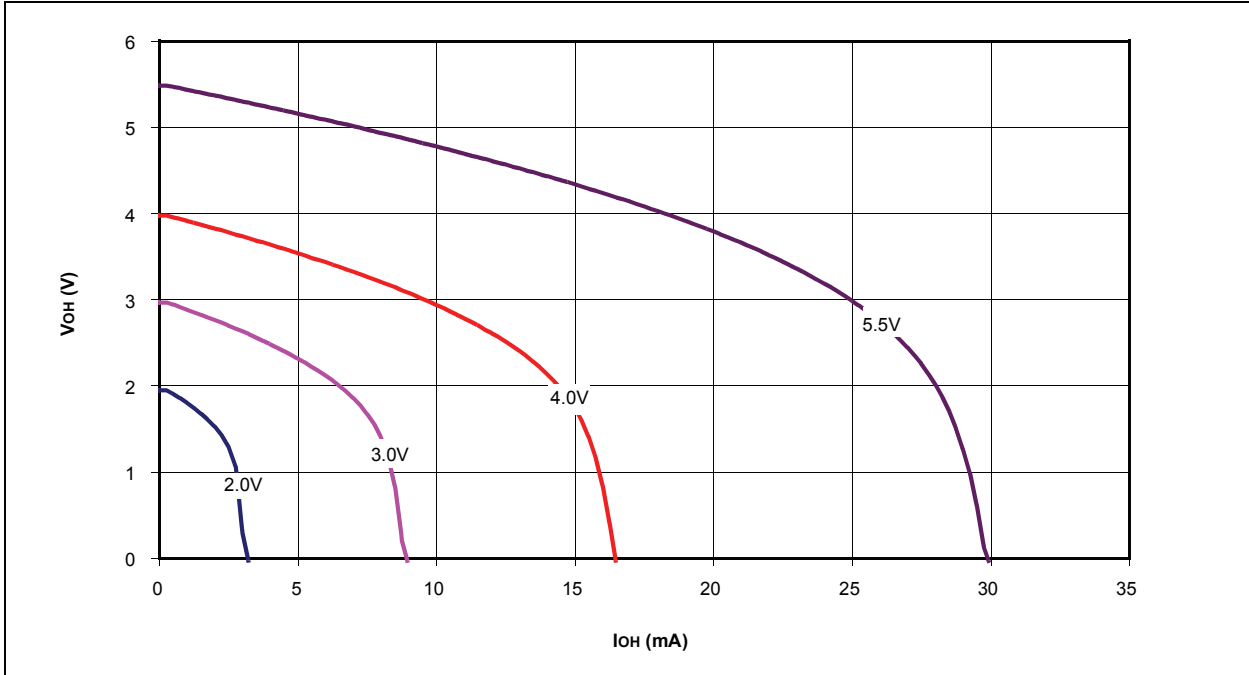
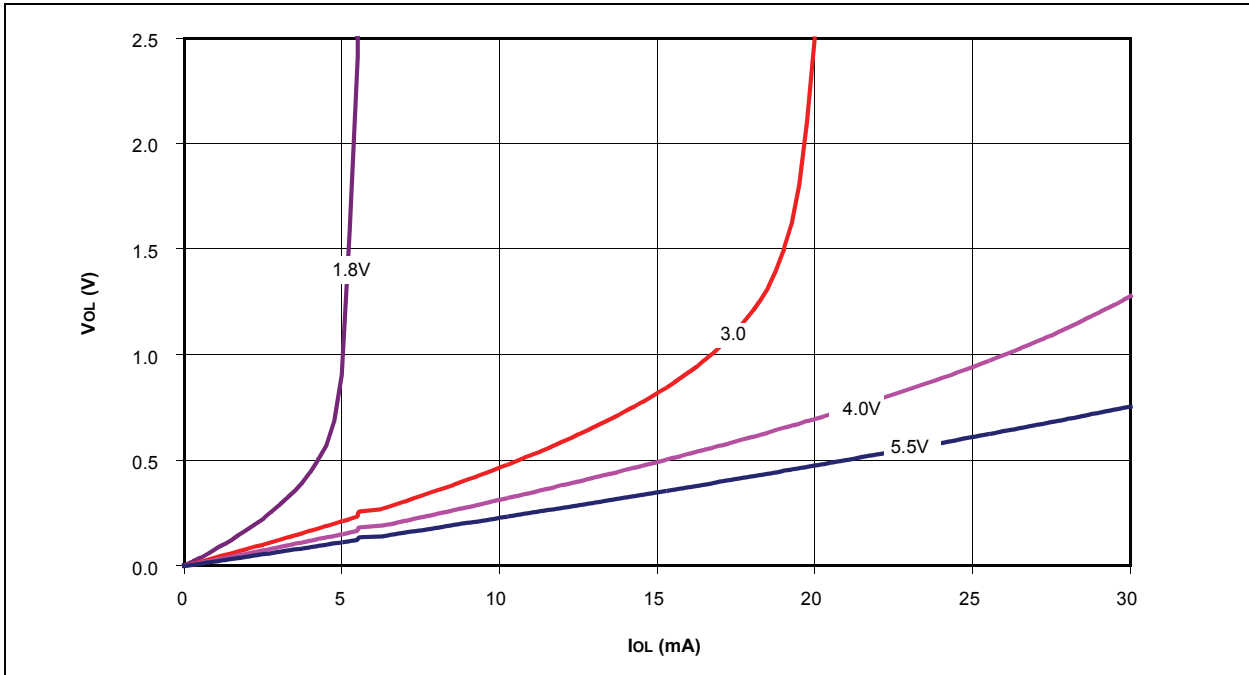


FIGURE 26-30: PIC18F1XK22 TYPICAL  $V_{OL}$  vs.  $I_{OL}$



# PIC18(L)F1XK22

---

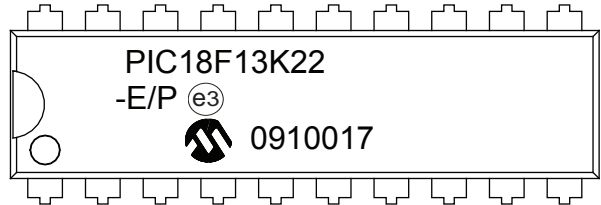
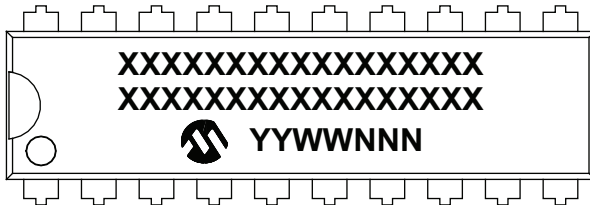
NOTES:

## 27.0 PACKAGING INFORMATION

### 27.1 Package Marking Information

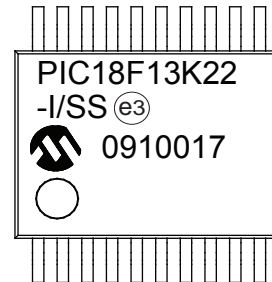
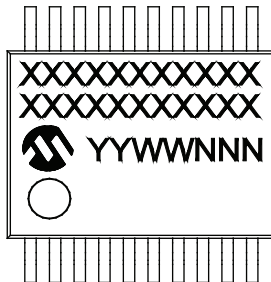
20-Lead PDIP (300 mil)

Example



20-Lead SSOP (5.30 mm)

Example



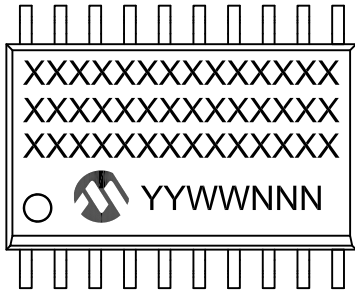
<b>Legend:</b>	XX...X	Customer-specific information
	Y	Year code (last digit of calendar year)
	YY	Year code (last 2 digits of calendar year)
	WW	Week code (week of January 1 is week '01')
	NNN	Alphanumeric traceability code
	(e3)	Pb-free JEDEC designator for Matte Tin (Sn)
	*	This package is Pb-free. The Pb-free JEDEC designator (e3) can be found on the outer packaging for this package.
<b>Note:</b>	In the event the full Microchip part number cannot be marked on one line, it will be carried over to the next line, thus limiting the number of available characters for customer-specific information.	

\* Standard PICmicro® device marking consists of Microchip part number, year code, week code and traceability code. For PICmicro device marking beyond this, certain price adders apply. Please check with your Microchip Sales Office. For QTP devices, any special marking adders are included in QTP price.

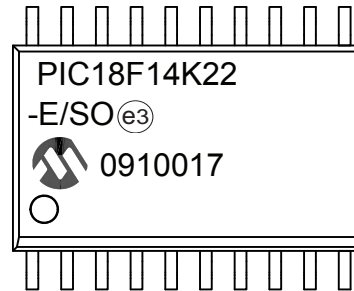
# PIC18(L)F1XK22

## 27.1 Package Marking Information (Continued)

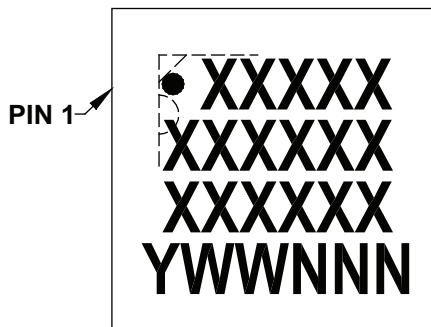
20-Lead SOIC (7.50 mm)



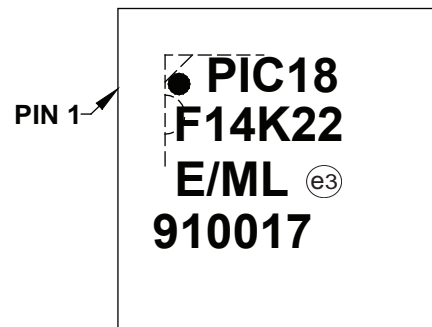
Example



20-Lead QFN (4x4x0.9 mm)



Example



<b>Legend:</b>	XX...X	Customer-specific information
	Y	Year code (last digit of calendar year)
	YY	Year code (last 2 digits of calendar year)
	WW	Week code (week of January 1 is week '01')
	NNN	Alphanumeric traceability code
	(e3)	Pb-free JEDEC designator for Matte Tin (Sn)
	*	This package is Pb-free. The Pb-free JEDEC designator (e3) can be found on the outer packaging for this package.
<b>Note:</b>	In the event the full Microchip part number cannot be marked on one line, it will be carried over to the next line, thus limiting the number of available characters for customer-specific information.	

\* Standard PICmicro® device marking consists of Microchip part number, year code, week code and traceability code. For PICmicro device marking beyond this, certain price adders apply. Please check with your Microchip Sales Office. For QTP devices, any special marking adders are included in QTP price.

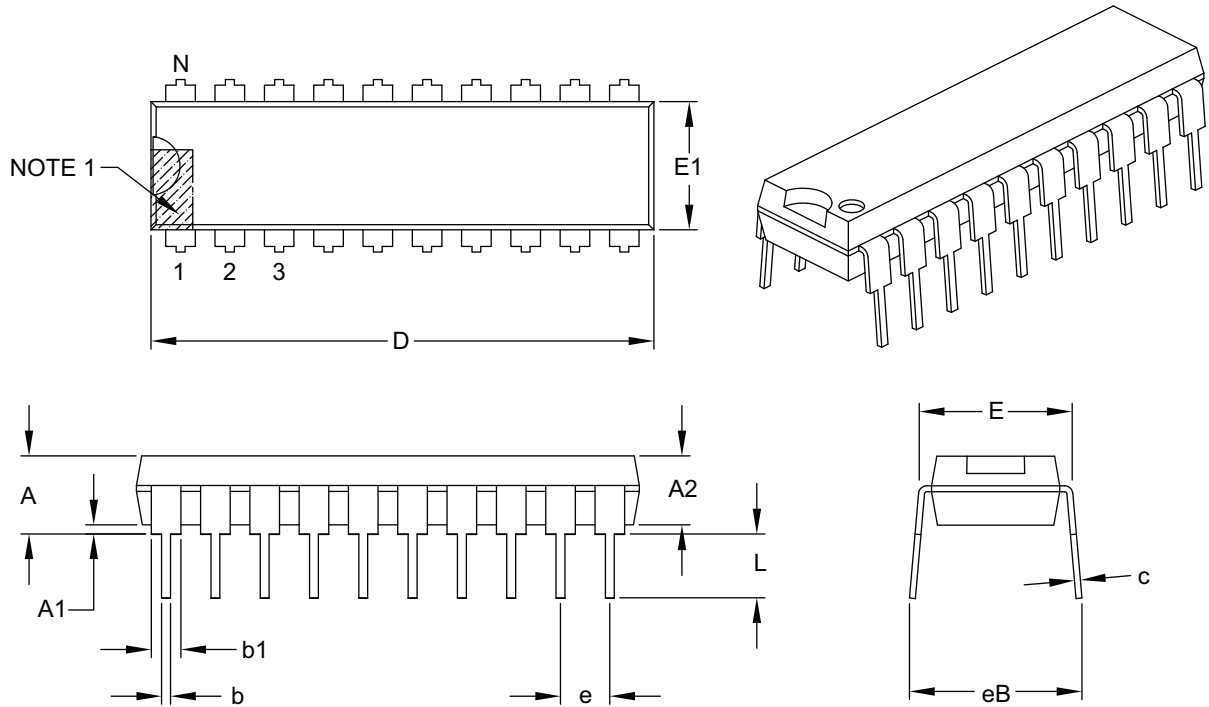
# PIC18(L)F1XK22

## 27.2 Package Details

The following sections give the technical details of the packages.

### 20-Lead Plastic Dual In-Line (P) – 300 mil Body [PDIP]

**Note:** For the most current package drawings, please see the Microchip Packaging Specification located at <http://www.microchip.com/packaging>



		Units	INCHES		
Dimension Limits			MIN	NOM	MAX
Number of Pins	N		20		
Pitch	e		.100 BSC		
Top to Seating Plane	A	–	–	–	.210
Molded Package Thickness	A2	.115	.130	.130	.195
Base to Seating Plane	A1	.015	–	–	–
Shoulder to Shoulder Width	E	.300	.310	.310	.325
Molded Package Width	E1	.240	.250	.250	.280
Overall Length	D	.980	1.030	1.030	1.060
Tip to Seating Plane	L	.115	.130	.130	.150
Lead Thickness	c	.008	.010	.010	.015
Upper Lead Width	b1	.045	.060	.060	.070
Lower Lead Width	b	.014	.018	.018	.022
Overall Row Spacing §	eB	–	–	–	.430

**Notes:**

1. Pin 1 visual index feature may vary, but must be located within the hatched area.
2. § Significant Characteristic.
3. Dimensions D and E1 do not include mold flash or protrusions. Mold flash or protrusions shall not exceed .010" per side.
4. Dimensioning and tolerancing per ASME Y14.5M.

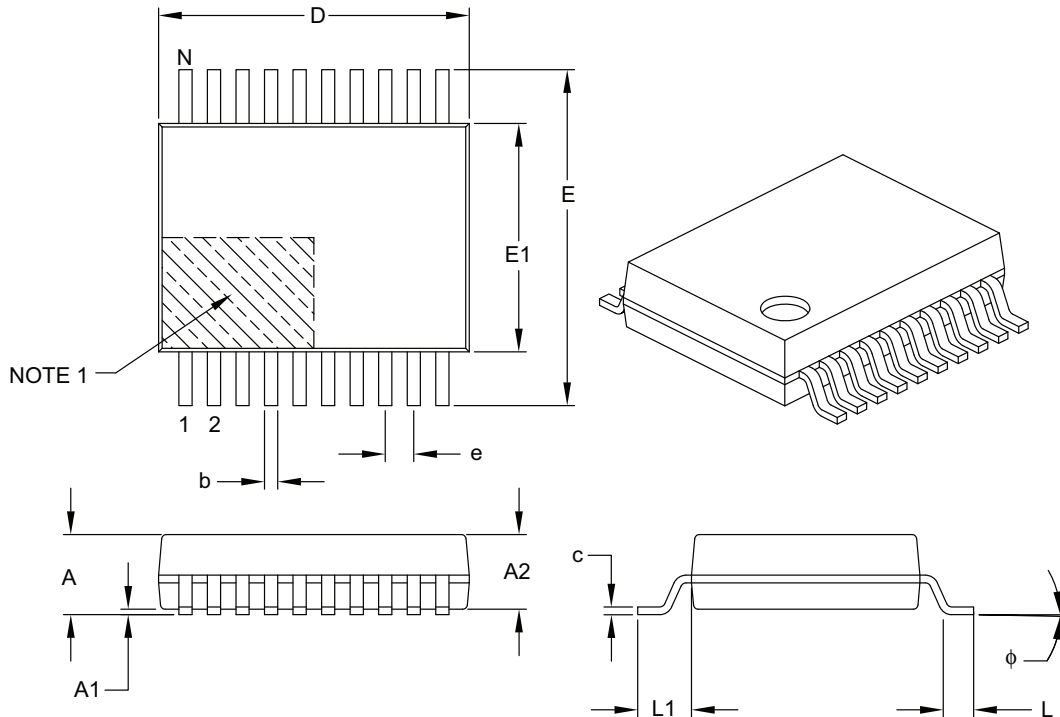
BSC: Basic Dimension. Theoretically exact value shown without tolerances.

Microchip Technology Drawing C04-019B

# PIC18(L)F1XK22

## 20-Lead Plastic Shrink Small Outline (SS) – 5.30 mm Body [SSOP]

**Note:** For the most current package drawings, please see the Microchip Packaging Specification located at <http://www.microchip.com/packageing>



Dimension Limits	Units	MILLIMETERS		
		MIN	NOM	MAX
Number of Pins	N	20		
Pitch	e	0.65 BSC		
Overall Height	A	–	–	2.00
Molded Package Thickness	A2	1.65	1.75	1.85
Standoff	A1	0.05	–	–
Overall Width	E	7.40	7.80	8.20
Molded Package Width	E1	5.00	5.30	5.60
Overall Length	D	6.90	7.20	7.50
Foot Length	L	0.55	0.75	0.95
Footprint	L1	1.25 REF		
Lead Thickness	c	0.09	–	0.25
Foot Angle	$\phi$	0°	4°	8°
Lead Width	b	0.22	–	0.38

**Notes:**

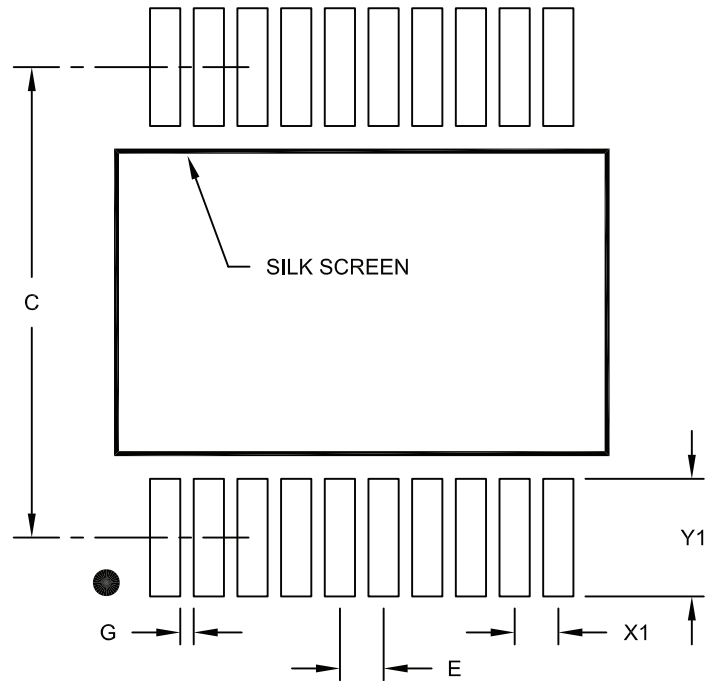
- Pin 1 visual index feature may vary, but must be located within the hatched area.
- Dimensions D and E1 do not include mold flash or protrusions. Mold flash or protrusions shall not exceed 0.20 mm per side.
- Dimensioning and tolerancing per ASME Y14.5M.
  - BSC: Basic Dimension. Theoretically exact value shown without tolerances.
  - REF: Reference Dimension, usually without tolerance, for information purposes only.

Microchip Technology Drawing C04-072B

# PIC18(L)F1XK22

## 20-Lead Plastic Shrink Small Outline (SS) - 5.30 mm Body [SSOP]

**Note:** For the most current package drawings, please see the Microchip Packaging Specification located at <http://www.microchip.com/packageing>



RECOMMENDED LAND PATTERN

Dimension Limits	Units	MILLIMETERS		
		MIN	NOM	MAX
Contact Pitch	E	0.65 BSC		
Contact Pad Spacing	C		7.20	
Contact Pad Width (X20)	X1			0.45
Contact Pad Length (X20)	Y1			1.75
Distance Between Pads	G	0.20		

**Notes:**

1. Dimensioning and tolerancing per ASME Y14.5M

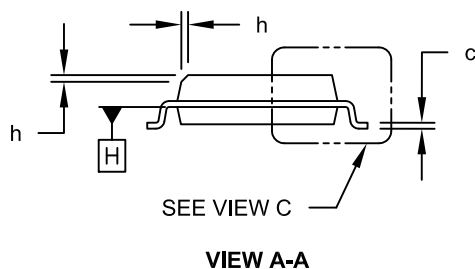
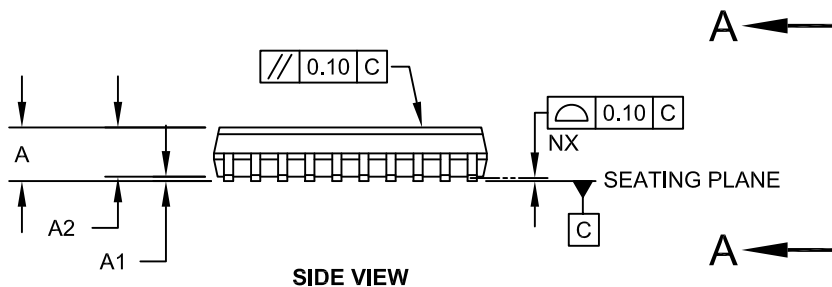
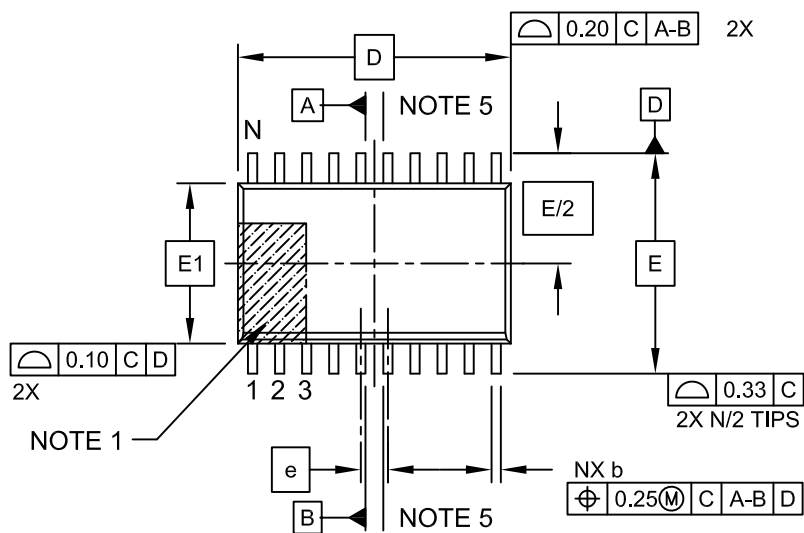
BSC: Basic Dimension. Theoretically exact value shown without tolerances.

Microchip Technology Drawing No. C04-2072A

# PIC18(L)F1XK22

## 20-Lead Plastic Small Outline (SO) - Wide, 7.50 mm Body [SOIC]

**Note:** For the most current package drawings, please see the Microchip Packaging Specification located at <http://www.microchip.com/packaging>

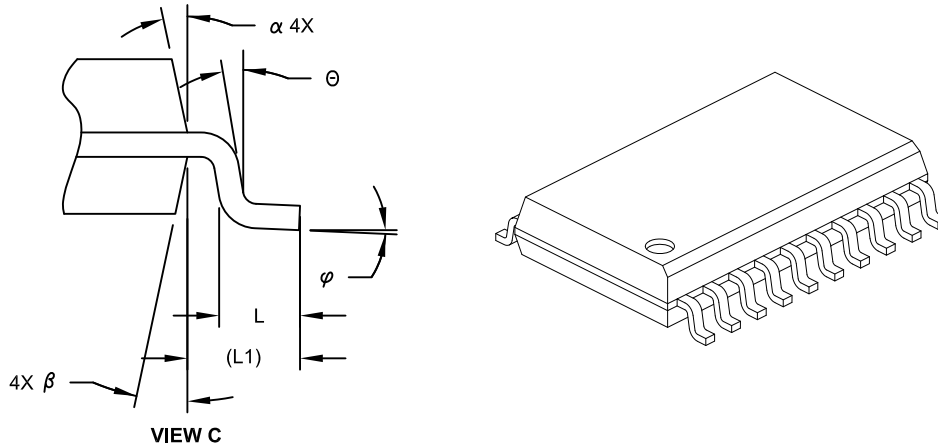


Microchip Technology Drawing C04-094C Sheet 1 of 2



## 20-Lead Plastic Small Outline (SO) - Wide, 7.50 mm Body [SOIC]

**Note:** For the most current package drawings, please see the Microchip Packaging Specification located at <http://www.microchip.com/packaging>



Dimension Limits	Units	MILLIMETERS		
		MIN	NOM	MAX
Number of Pins	N	20		
Pitch	e	1.27 BSC		
Overall Height	A	-	-	2.65
Molded Package Thickness	A2	2.05	-	-
Standoff §	A1	0.10	-	0.30
Overall Width	E	10.30 BSC		
Molded Package Width	E1	7.50 BSC		
Overall Length	D	12.80 BSC		
Chamfer (Optional)	h	0.25	-	0.75
Foot Length	L	0.40	-	1.27
Footprint	L1	1.40 REF		
Lead Angle	$\Theta$	0°	-	-
Foot Angle	$\varphi$	0°	-	8°
Lead Thickness	c	0.20	-	0.33
Lead Width	b	0.31	-	0.51
Mold Draft Angle Top	$\alpha$	5°	-	15°
Mold Draft Angle Bottom	$\beta$	5°	-	15°

**Notes:**

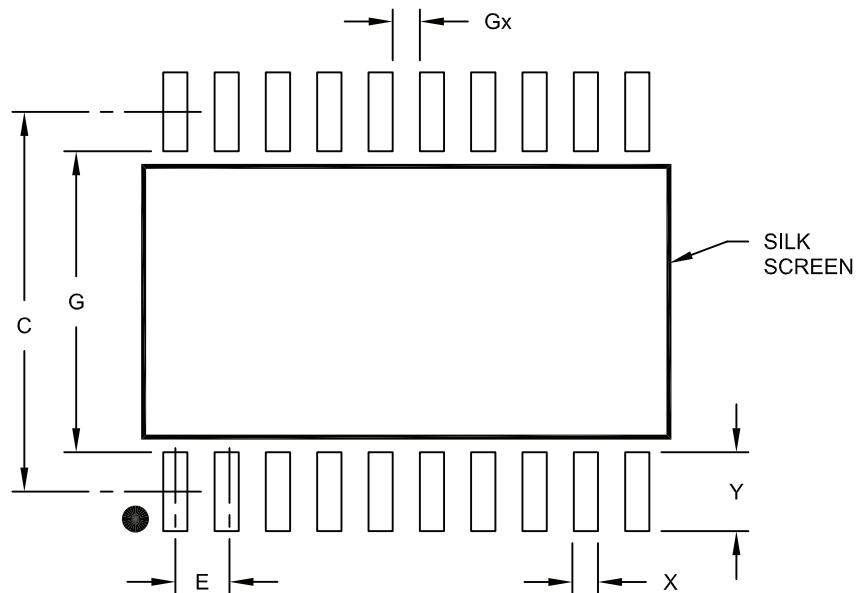
- Pin 1 visual index feature may vary, but must be located within the hatched area.
- § Significant Characteristic
- Dimension D does not include mold flash, protrusions or gate burrs, which shall not exceed 0.15 mm per end. Dimension E1 does not include interlead flash or protrusion, which shall not exceed 0.25 mm per side.
- Dimensioning and tolerancing per ASME Y14.5M  
 BSC: Basic Dimension. Theoretically exact value shown without tolerances.  
 REF: Reference Dimension, usually without tolerance, for information purposes only.
- Datums A & B to be determined at Datum H.

Microchip Technology Drawing No. C04-094C Sheet 2 of 2

# PIC18(L)F1XK22

20-Lead Plastic Small Outline (SO) - Wide, 7.50 mm Body [SOIC]

**Note:** For the most current package drawings, please see the Microchip Packaging Specification located at <http://www.microchip.com/packaging>



RECOMMENDED LAND PATTERN

Dimension Limits	Units	MILLIMETERS		
		MIN	NOM	MAX
Contact Pitch	E	1.27 BSC		
Contact Pad Spacing	C		9.40	
Contact Pad Width (X20)	X			0.60
Contact Pad Length (X20)	Y			1.95
Distance Between Pads	Gx	0.67		
Distance Between Pads	G	7.45		

Notes:

1. Dimensioning and tolerancing per ASME Y14.5M

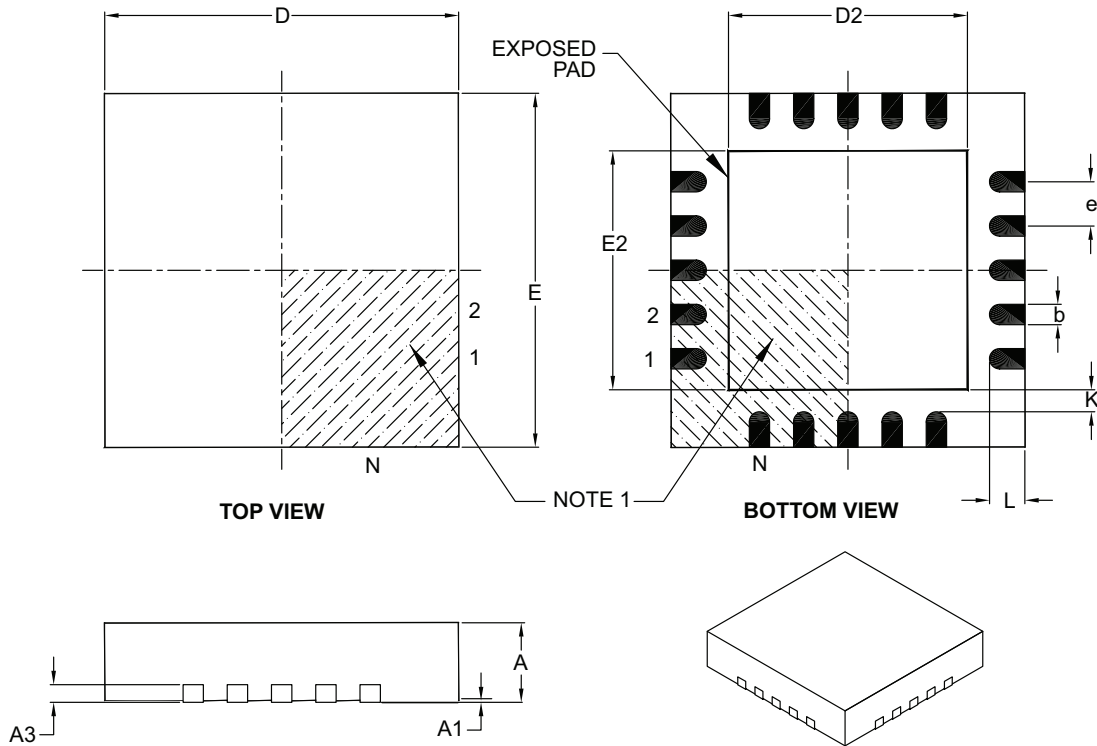
BSC: Basic Dimension. Theoretically exact value shown without tolerances.

Microchip Technology Drawing No. C04-2094A

# PIC18(L)F1XK22

## 20-Lead Plastic Quad Flat, No Lead Package (ML) – 4x4x0.9 mm Body [QFN]

**Note:** For the most current package drawings, please see the Microchip Packaging Specification located at <http://www.microchip.com/packaging>



Dimension Limits	Units	MILLIMETERS		
		MIN	NOM	MAX
Number of Pins	N	20		
Pitch	e	0.50 BSC		
Overall Height	A	0.80	0.90	1.00
Standoff	A1	0.00	0.02	0.05
Contact Thickness	A3	0.20 REF		
Overall Width	E	4.00 BSC		
Exposed Pad Width	E2	2.60	2.70	2.80
Overall Length	D	4.00 BSC		
Exposed Pad Length	D2	2.60	2.70	2.80
Contact Width	b	0.18	0.25	0.30
Contact Length	L	0.30	0.40	0.50
Contact-to-Exposed Pad	K	0.20	–	–

**Notes:**

- Pin 1 visual index feature may vary, but must be located within the hatched area.
- Package is saw singulated.
- Dimensioning and tolerancing per ASME Y14.5M.

BSC: Basic Dimension. Theoretically exact value shown without tolerances.

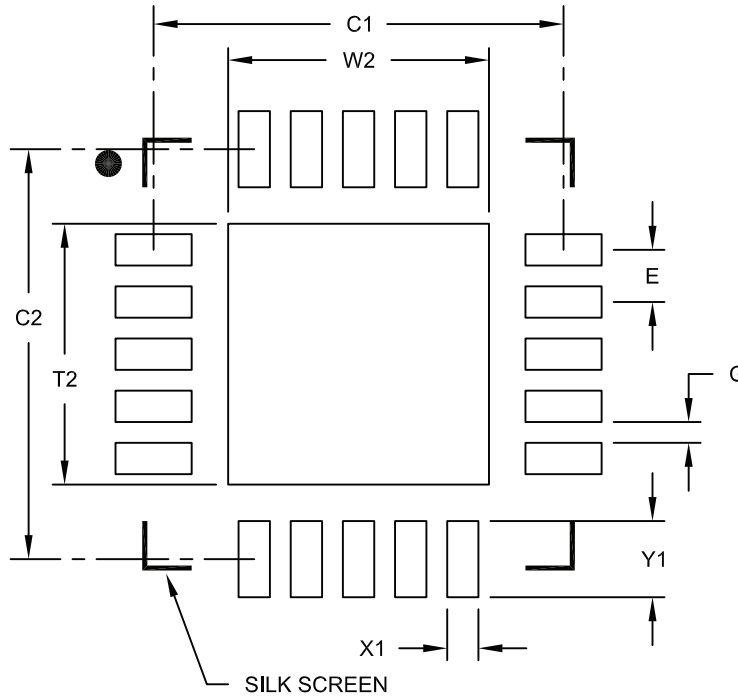
REF: Reference Dimension, usually without tolerance, for information purposes only.

Microchip Technology Drawing C04-126B

# PIC18(L)F1XK22

20-Lead Plastic Quad Flat, No Lead Package (ML) - 4x4 mm Body [QFN]  
With 0.40 mm Contact Length

**Note:** For the most current package drawings, please see the Microchip Packaging Specification located at <http://www.microchip.com/packaging>



RECOMMENDED LAND PATTERN

Dimension Limits	Units	MILLIMETERS		
		MIN	NOM	MAX
Contact Pitch	E	0.50 BSC		
Optional Center Pad Width	W2			2.50
Optional Center Pad Length	T2			2.50
Contact Pad Spacing	C1		3.93	
Contact Pad Spacing	C2		3.93	
Contact Pad Width	X1			0.30
Contact Pad Length	Y1			0.73
Distance Between Pads	G	0.20		

Notes:

1. Dimensioning and tolerancing per ASME Y14.5M

BSC: Basic Dimension. Theoretically exact value shown without tolerances.

Microchip Technology Drawing No. C04-2126A

## APPENDIX A: REVISION HISTORY

### Revision A (February 2009)

Original data sheet for PIC18(L)F1XK22 devices.

### Revision B (04/2009)

Revised data sheet title; Revised Peripheral Features section; Revised Table 3-1, Table 3-2; Revised Example 15-1; Revised Table 21-4.

### Revision C (10/2009)

Updated Table 1-1; Updated the “Electrical Specifications” section (Figures 25-1 to 25-4; sub-sections 25.1, 25.2, 25.3, 25.4, 25.5, 25.6, 25.7, 25.8, Added Param No. OS09 to Table 25-2; Added Param No. D003A and Note 1 to Table 25-12); Added graphs to the “DC and AC Characteristics Graphs and Charts” section; Other minor corrections.

### Revision D (05/2010)

Revised Section 1.3 (deleted #2); Revised Figure 1-1; Added Table 2-4; Removed register EEADRH from Tables 3-1 and 3-2; Revised Section 5 (Data EEPROM Memory); Updated Example 5-2 and Table 5-1; Revised Section 13.4.4 (Enhanced PWM Auto-Shutdown Mode); Added Note 4 below Register 13-2; Revised Figure 16-1; Revised Equation 20-1; Removed sub-section 20.1.3 (Output Clamped to VSS); Updated Figure 20-1; Revised Tables 21-4 and Table 22-1; Updated Register 22-5, Figure 25-5, Table 25-2, Table 25-8, Table 25-10 and Table 25-12; Updated the Electrical Specification section; Other minor corrections.

### Revision E (10/2011)

Updated data sheet to new format; Updated the Pin Diagrams; Updated the Electrical Specifications section; Updated the Packaging Information section; Updated Table B-1; Updated the Product Identification System section; Other minor corrections.

## APPENDIX B: DEVICE DIFFERENCES

The differences between the devices listed in this data sheet are shown in [Table B-1](#).

**TABLE B-1: DEVICE DIFFERENCES**

Features	PIC18F13K22	PIC18F14K22	PIC18LF13K22	PIC18LF14K22
Program Memory (Bytes)	8192	16384	8192	16384
Program Memory (Instructions)	4096	8192	4096	8192
Data Memory SRAM (bytes)	256	512	256	512
Data Memory EEPROM (bytes)	256	256	256	256
VDD Min <sup>(V)</sup>	2.3	2.3	1.8	1.8
VDD Max <sup>(V)</sup>	5.5	5.5	3.6	3.6
Packages	20-pin PDIP 20-pin SOIC 20-pin SSOP 20-Pin QFN	20-pin PDIP 20-pin SOIC 20-pin SSOP 20-Pin QFN	20-pin PDIP 20-pin SOIC 20-pin SSOP 20-Pin QFN	20-pin PDIP 20-pin SOIC 20-pin SSOP 20-Pin QFN

# PIC18(L)F1XK22

---

NOTES:

# PIC18(L)F1XK22

<b>A</b>		
A/D		
Analog Port Pins, Configuring	215	
Associated Registers	215	
Conversions	206	
Discharge	207	
Selecting and Configuring Acquisition Time	204	
Specifications	353	
Absolute Maximum Ratings	327	
AC Characteristics		
Industrial and Extended	346	
Load Conditions	345	
Access Bank		
Mapping with Indexed Literal Offset Mode	45	
ACKSTAT	165	
ACKSTAT Status Flag	165	
ADC	203	
Acquisition Requirements	213	
Block Diagram	203	
Calculating Acquisition Time	213	
Channel Selection	204	
Configuration	204	
Conversion Clock	204	
Conversion Procedure	208	
Internal Sampling Switch (RSS) IMPEDANCE	213	
Interrupts	205	
Operation	206	
Operation During Sleep	207	
Port Configuration	204	
Power Management	207	
Reference Voltage (VREF)	204	
Result Formatting	205	
Source Impedance	213	
Special Event Trigger	207	
Starting an A/D Conversion	205	
ADCON0 Register	209	
ADCON1 Register	210, 211	
ADDFSR	316	
ADDLW	279	
ADDLWLNK	316	
ADDWF	279	
ADDWFC	280	
ADRESH Register (ADFM = 0)	212	
ADRESH Register (ADFM = 1)	212	
ADRESL Register (ADFM = 0)	212	
ADRESL Register (ADFM = 1)	212	
Analog Input Connection Considerations	225	
Analog-to-Digital Converter. See ADC		
ANDLW	280	
ANDWF	281	
ANSEL Register	92	
ANSELH Register	93	
Assembler		
MPASM Assembler	324	
<b>B</b>		
Bank Select Register (BSR)	31	
Baud Rate Generator	161	
BAUDCON Register	186	
BC	281	
BCF	282	
BF	165	
BF Status Flag	165	
Block Diagrams		
ADC	203	
ADC Transfer Function	214	
Analog Input Model	214, 225	
Baud Rate Generator	161	
Capture Mode Operation	113	
Clock Source	14	
Comparator 1	218	
Comparator 2	219	
Crystal Operation	15	
EUSART Receive	176	
EUSART Transmit	175	
External POR Circuit (Slow VDD Power-up)	247	
External RC Mode	16	
Fail-Safe Clock Monitor (FSCM)	23	
Generic I/O Port	77	
Interrupt Logic	64	
MSSP (I <sup>2</sup> C Master Mode)	159	
MSSP (I <sup>2</sup> C Mode)	142	
MSSP (SPI Mode)	133	
On-Chip Reset Circuit	245	
PIC18(L)F1XK22	10	
PWM (Enhanced)	115	
Reads from Flash Program Memory	51	
Resonator Operation	16	
Table Read Operation	47	
Table Write Operation	48	
Table Writes to Flash Program Memory	53	
Timer0 in 16-Bit Mode	97	
Timer0 in 8-Bit Mode	96	
Timer1	100	
Timer1 (16-Bit Read/Write Mode)	101	
Timer2	106	
Timer3	108	
Timer3 (16-Bit Read/Write Mode)	109	
Voltage Reference	240	
Voltage Reference Output Buffer Example	241	
Watchdog Timer	267	
BN	282	
BNC	283	
BNN	283	
BNOV	284	
BNZ	284	
BOR. See Brown-out Reset.		
BOV	287	
BRA	285	
Break Character (12-bit) Transmit and Receive	194	
BRG. See Baud Rate Generator.		
Brown-out Reset (BOR)	248	
Detecting	248	
Disabling in Sleep Mode	248	
Software Enabled	248	
Specifications	351	
Timing and Characteristics	350	
BSF	285	
BTFSC	286	
BTFSS	286	
BTG	287	
BZ	288	
<b>C</b>		
C Compilers		
MPLAB C18	324	
CALL	288	
CALLW	317	
Capture (CCP Module)	112	
CCP Pin Configuration	112	
CCPRxH:CCPRxL Registers	112	

# PIC18(L)F1XK22

Prescaler .....	113	Timer1/Timer3 Mode Selection.....	114
Software Interrupt .....	112	Computed GOTO.....	28
Timer1/Timer3 Mode Selection.....	112	CONFIG1H Register .....	259
Capture/Compare/PWM (CCP)		CONFIG2H Register .....	261
Capture Mode. See Capture.		CONFIG2L Register .....	260
CCP Mode and Timer Resources .....	112	CONFIG3H Register .....	262
Compare Mode. See Compare.		CONFIG4L Register .....	262
CCP1CON Register .....	111	CONFIG5H Register .....	263
Clock Accuracy with Asynchronous Operation .....	184	CONFIG5L Register .....	263
Clock Sources		CONFIG6H Register .....	264
Associated registers.....	24	CONFIG6L Register .....	264
External Modes		CONFIG7H Register .....	265
HS.....	15	CONFIG7L Register .....	265
LP.....	15	Configuration Bits .....	258
XT .....	15	Configuration Register Protection.....	272
CLRFB.....	289	Context Saving During Interrupts.....	75
CLRWDT.....	289	CPFSEQ.....	290
CM1CON0 Register .....	223	CPFSGT .....	291
CM2CON0 Register .....	224	CPFSLT .....	291
CM2CON1 Register .....	227	Customer Change Notification Service.....	401
Code Examples		Customer Notification Service .....	401
16 x 16 Signed Multiply Routine .....	62	Customer Support.....	401
16 x 16 Unsigned Multiply Routine .....	62	CVREF Voltage Reference Specifications .....	355
8 x 8 Signed Multiply Routine .....	61		
8 x 8 Unsigned Multiply Routine .....	61	<b>D</b>	
A/D Conversion.....	208	Data Addressing Modes .....	41
Changing Between Capture Prescalers.....	113	Comparing Addressing Modes with the	
Clearing RAM Using Indirect Addressing.....	41	Extended Instruction Set Enabled .....	44
Computed GOTO Using an Offset Value.....	28	Direct .....	41
Data EEPROM Read .....	59	Indexed Literal Offset .....	43
Data EEPROM Refresh Routine.....	60	Instructions Affected .....	43
Data EEPROM Write .....	59	Indirect.....	41
Erasing a Flash Program Memory Row .....	52	Inherent and Literal.....	41
Fast Register Stack.....	28	Data EEPROM	
Implementing a Timer1 Real-Time Clock.....	104	Code Protection.....	272
Initializing PORTA.....	78	Data EEPROM Memory.....	57
Initializing PORTB.....	83	Associated Registers .....	60
Initializing PORTC.....	88	EEADR Register .....	57
Loading the SSPBUF (SSPSR) Register.....	136	EECON1 and EECON2 Registers.....	57
Reading a Flash Program Memory Word .....	51	Operation During Code-Protect .....	60
Saving Status, WREG and BSR Registers in RAM .....	75	Protection Against Spurious Write .....	60
Writing to Flash Program Memory .....	54–55	Reading .....	59
Code Protection .....	257	Using .....	60
COMF.....	290	Write Verify .....	59
Comparator		Writing .....	59
Associated Registers .....	228	Data Memory .....	31
Operation .....	217	Access Bank .....	35
Operation During Sleep .....	222	Access RAM .....	31
Response Time.....	220	and the Extended Instruction Set .....	43
Comparator Module .....	217	Bank Select Register (BSR) .....	31
C1 Output State Versus Input Conditions .....	220	General Purpose Registers .....	35
Comparator Voltage Reference (CVREF)		Map for PIC18F13K50/PIC18LF13K50 .....	32
Associated Registers .....	243	Map for PIC18F14K50/PIC18LF14K50 .....	33
Effects of a Reset.....	222, 239	Special Function Registers .....	35
Operation During Sleep .....	239	DAW .....	292
Overview .....	239	DC and AC Characteristics	
Comparator Voltage Reference (CVREF)		Graphs and Tables .....	363
Response Time.....	220	DC Characteristics	
Comparators		Extended and Industrial.....	341
Effects of a Reset.....	222	Industrial and Extended.....	331
Compare (CCP Module).....	114	DCFSNZ .....	293
CCPRx Register.....	114	DECF .....	292
Pin Configuration .....	114	DECFSZ .....	293
Software Interrupt .....	114	Development Support.....	323
Special Event Trigger.....	110, 114	Device Differences.....	389
		Device Overview.....	7



# PIC18(L)F1XK22

Details on Individual Family Members .....	8
Features (20-Pin Devices) .....	9
New Core Features .....	7
Other Special Features .....	8
Device Reset Timers .....	249
Oscillator Start-up Timer (OST) .....	249
PLL Lock Time-out .....	249
Power-up Timer (PWRT) .....	249
Time-out Sequence .....	249
DEVID1 Register .....	266
DEVID2 Register .....	266
Direct Addressing .....	42

## E

ECCPAS Register .....	123
EECON1 Register .....	49, 58
Effect on Standard PIC Instructions .....	320
Electrical Specifications .....	327
Enhanced Capture/Compare/PWM (ECCP) .....	111
Associated Registers .....	131
Enhanced PWM Mode .....	115
Auto-Restart .....	125
Auto-shutdown .....	123
Direction Change in Full-Bridge Output Mode ..	121
Full-Bridge Application .....	119
Full-Bridge Mode .....	119
Half-Bridge Application .....	118
Half-Bridge Application Examples .....	126
Half-Bridge Mode .....	118
Output Relationships (Active-High and Active-Low) .....	116
Output Relationships Diagram .....	117
Programmable Dead Band Delay .....	126
Shoot-through Current .....	126
Start-up Considerations .....	122
Outputs and Configuration .....	112
Specifications .....	353
Enhanced Universal Synchronous Asynchronous Receiver Transmitter (EUSART) .....	175
Errata .....	6
EUSART .....	175
Asynchronous Mode .....	177
12-bit Break Transmit and Receive .....	194
Associated Registers, Receive .....	183
Associated Registers, Transmit .....	179
Auto-Wake-up on Break .....	192
Baud Rate Generator (BRG) .....	187
Clock Accuracy .....	184
Receiver .....	180
Setting up 9-bit Mode with Address Detect .....	182
Transmitter .....	177
Baud Rate Generator (BRG) .....	187
Associated Registers .....	187
Auto Baud Rate Detect .....	191
Baud Rate Error, Calculating .....	187
Baud Rates, Asynchronous Modes .....	188
Formulas .....	187
High Baud Rate Select (BRGH Bit) .....	187
Clock polarity .....	195
Synchronous Mode .....	195
Data polarity .....	180
Asynchronous Receive .....	180
Asynchronous Transmit .....	177
Synchronous Mode .....	195
Interrupts .....	181
Asynchronous Receive .....	181

Asynchronous Transmit .....	177
Synchronous Master Mode .....	195, 200
Associated Registers, Receive .....	199
Associated Registers, Transmit .....	197, 200
Reception .....	197
Transmission .....	195
Synchronous Slave Mode .....	201
Associated Registers, Receive .....	201
Reception .....	201
Transmission .....	200
Extended Instruction Set .....	316
ADDFSR .....	316
ADDULNK .....	316
and Using MPLAB Tools .....	322
CALLW .....	317
Considerations for Use .....	320
MOVSF .....	317
MOVSS .....	318
PUSHL .....	318
SUBFSR .....	319
SUBULNK .....	319
Syntax .....	315

## F

Fail-Safe Clock Monitor .....	23, 257
Fail-Safe Condition Clearing .....	23
Fail-Safe Detection .....	23
Fail-Safe Operation .....	23
Reset or Wake-up from Sleep .....	23
Fast Register Stack .....	28
Firmware Instructions .....	273
Flash Program Memory .....	47
Associated Registers .....	55
Control Registers .....	48
EECON1 and EECON2 .....	48
TABLAT (Table Latch) Register .....	50
TBLPTR (Table Pointer) Register .....	50
Erase Sequence .....	52
Erasing .....	52
Operation During Code-Protect .....	55
Reading .....	51
Table Pointer .....	50
Boundaries Based on Operation .....	50
Table Pointer Boundaries .....	50
Table Reads and Table Writes .....	47
Write Sequence .....	53
Writing To .....	53
Protection Against Spurious Writes .....	55
Unexpected Termination .....	55
Write Verify .....	55

## G

General Call Address Support .....	158
GOTO .....	294

## H

Hardware Multiplier .....	61
Introduction .....	61
Operation .....	61
Performance Comparison .....	61

## I

I/O Ports .....	77
I <sup>2</sup> C .....	174
Associated Registers .....	174
I <sup>2</sup> C Mode (MSSP) .....	

# PIC18(L)F1XK22

Acknowledge Sequence Timing.....	168	BSF (Indexed Literal Offset Mode).....	321
Baud Rate Generator.....	161	BTFSC.....	286
Bus Collision		BTFSS.....	286
During a Repeated Start Condition.....	172	BTG.....	287
During a Stop Condition.....	173	BZ.....	288
Clock Arbitration.....	162	CALL.....	288
Clock Stretching.....	154	CLRF.....	289
10-Bit Slave Receive Mode (SEN = 1).....	154	CLRWDT.....	289
10-Bit Slave Transmit Mode.....	154	COMF.....	290
7-Bit Slave Receive Mode (SEN = 1).....	154	CPFSEQ.....	290
7-Bit Slave Transmit Mode.....	154	CPFSGT.....	291
Clock Synchronization and the CKP bit (SEN = 1) ...	155	CPFSLT.....	291
Effects of a Reset.....	169	DAW.....	292
General Call Address Support.....	158	DCFSNZ.....	293
I <sup>2</sup> C Clock Rate w/BRG.....	161	DECF.....	292
Master Mode.....	159	DECFSZ.....	293
Operation.....	160	Extended Instruction Set.....	315
Reception.....	165	General Format.....	275
Repeated Start Condition Timing.....	164	GOTO.....	294
Start Condition Timing.....	163	INCF.....	294
Transmission.....	165	INCFSZ.....	295
Multi-Master Communication, Bus Collision and		INFNSZ.....	295
Arbitration.....	169	IORLW.....	296
Multi-Master Mode.....	169	IORWF.....	296
Operation.....	146	LFSR.....	297
Read/Write Bit Information (R/W Bit).....	146, 147	MOVF.....	297
Registers.....	142	MOVFF.....	298
Serial Clock (RC3/SCK/SCL).....	147	MOVLB.....	298
Slave Mode.....	146	MOVLW.....	299
Addressing.....	146	MOVWF.....	299
Reception.....	147	MULLW.....	300
Transmission.....	147	MULWF.....	300
Sleep Operation.....	169	NEGF.....	301
Stop Condition Timing.....	168	NOP.....	301
ID Locations.....	257, 272	Opcode Field Descriptions.....	274
INCF.....	294	POP.....	302
INCFSZ.....	295	PUSH.....	302
In-Circuit Debugger.....	272	RCALL.....	303
In-Circuit Serial Programming (ICSP).....	257, 272	RESET.....	303
Indexed Literal Offset Addressing		RETFIE.....	304
and Standard PIC18 Instructions.....	320	RETLW.....	304
Indexed Literal Offset Mode.....	320	RETURN.....	305
Indirect Addressing.....	42	RLCF.....	305
INFNSZ.....	295	RLNCF.....	306
Initialization Conditions for all Registers.....	253	RRCF.....	306
Instruction Cycle.....	29	RRNCF.....	307
Clocking Scheme.....	29	SETF.....	307
Instruction Flow/Pipelining.....	29	SETF (Indexed Literal Offset Mode).....	321
Instruction Set.....	273	SLEEP.....	308
ADDLW.....	279	SUBFWB.....	308
ADDWF.....	279	SUBLW.....	309
ADDWF (Indexed Literal Offset Mode).....	321	SUBWF.....	309
ADDWFC.....	280	SUBWFB.....	310
ANDLW.....	280	SWAPF.....	310
ANDWF.....	281	TBLRD.....	311
BC.....	281	TBLWT.....	312
BCF.....	282	TSTFSZ.....	313
BN.....	282	XORLW.....	313
BNC.....	283	XORWF.....	314
BNN.....	283	INTCON Register.....	65
BNOV.....	284	INTCON Registers.....	65–67
BNZ.....	284	INTCON2 Register.....	66
BOV.....	287	INTCON3 Register.....	67
BRA.....	285	Inter-Integrated Circuit. See I <sup>2</sup> C.	
BSF.....	285	Internal Oscillator Block	

# PIC18(L)F1XK22

INTOSC	
Specifications.....	348, 349
Internal RC Oscillator	
Use with WDT.....	267
Internal Sampling Switch (Rss) IMPEDANCE.....	213
Internet Address.....	401
Interrupt Sources.....	257
ADC.....	205
Capture Complete (CCP).....	112
Compare Complete (CCP).....	114
Interrupt-on-Change (RB7:RB4).....	77, 83
INTx Pin.....	75
PORTB, Interrupt-on-Change.....	75
TMR0.....	75
TMR0 Overflow.....	97
TMR1 Overflow.....	99
TMR3 Overflow.....	107, 110
Interrupts.....	63
INTOSC Specifications.....	348, 349
IOCA Register.....	80
IOCB Register.....	85
IORLW.....	296
IORWF.....	296
IPR Registers.....	72
IPR1 Register.....	72
IPR2 Register.....	73
<b>L</b>	
LATA Register.....	80
LATB Register.....	84
LATC Register.....	89
LFSR.....	297
Load Conditions.....	345
Low-Voltage ICSP Programming. <i>See</i> Single-Supply ICSP Programming	
<b>M</b>	
Master Clear ( $\overline{\text{MCLR}}$ ).....	247
Master Synchronous Serial Port (MSSP). <i>See</i> MSSP.	
Memory Organization.....	25
Data Memory.....	31
Program Memory.....	25
Microchip Internet Web Site.....	401
MOVF.....	297
MOVFF.....	298
MOVLB.....	298
MOVLW.....	299
MOVSF.....	317
MOVSS.....	318
MOVWF.....	299
MPLAB ASM30 Assembler, Linker, Librarian.....	324
MPLAB Integrated Development Environment Software.....	323
MPLAB PM3 Device Programmer.....	326
MPLAB REAL ICE In-Circuit Emulator System.....	325
MPLINK Object Linker/MPLIB Object Librarian.....	324
MSSP	
ACK Pulse.....	146, 147
I <sup>2</sup> C Mode. <i>See</i> I <sup>2</sup> C Mode.	
Module Overview.....	133
SPI Mode. <i>See</i> SPI Mode.	
SSPBUF Register.....	138
SSPSR Register.....	138
MULLW.....	300
MULWF.....	300

<b>N</b>	
NEGF.....	301
NOP.....	301
<b>O</b>	
OSCCON Register.....	18, 19
Oscillator Parameters.....	348
Oscillator Selection.....	257
Oscillator Start-up Timer (OST).....	249
Specifications.....	351
Oscillator Switching	
Fail-Safe Clock Monitor.....	23
Oscillator, Timer1.....	99, 110
Oscillator, Timer3.....	107
OSCTUNE Register.....	20
<b>P</b>	
P1A/P1B/P1C/P1D. <i>See</i> Enhanced Capture/Compare/ PWM (ECCP).....	115
Packaging Information.....	379
Marking.....	379, 380
PIE Registers.....	70
PIE1 Register.....	70
PIE2 Register.....	71
PIR Registers.....	68
PIR1 Register.....	68
PIR2 Register.....	69
POP.....	302
POR. <i>See</i> Power-on Reset.	
PORTA	
Associated Registers.....	82
LATA Register.....	77
PORTA Register.....	77
Specifications.....	349
TRISA Register.....	77
PORTA Register.....	79
PORTB	
Associated Registers.....	87
LATB Register.....	83
PORTB Register.....	83
TRISB Register.....	83
PORTB Register.....	84, 88
PORTC	
Associated Registers.....	91
LATC Register.....	88
PORTC Register.....	88
RC3/SCK/SCL Pin.....	147
Specifications.....	349
TRISC Register.....	88
Power Managed Modes.....	229
and A/D Operation.....	207
and PWM Operation.....	131
and SPI Operation.....	141
Entering.....	229
Exiting Idle and Sleep Modes.....	233
by Interrupt.....	233
by Reset.....	234
by WDT Time-out.....	233
Without a Start-up Delay.....	234
Idle Modes.....	231
PRI_IDLE.....	232
RC_IDLE.....	233
SEC_IDLE.....	232
Multiple Sleep Functions.....	230
Run Modes.....	230

# PIC18(L)F1XK22

PRI_RUN .....	230	ANSELH (Analog Select High) .....	93
RC_RUN .....	230	BAUDCON (EUSART Baud Rate Control) .....	186
SEC_RUN .....	230	CCP1CON (Enhanced Capture/Compare/PWM	
Selecting .....	229	Control) .....	111
Sleep Mode .....	231	CM1CON0 (C1 Control) .....	223
Summary (table) .....	229	CM2CON0 (C2 Control) .....	224
Power-on Reset (POR) .....	247	CM2CON1 (C2 Control) .....	227
Power-up Timer (PWRT) .....	249	CONFIG1H (Configuration 1 High) .....	259
Time-out Sequence .....	249	CONFIG2H (Configuration 2 High) .....	261
Power-up Timer (PWRT)		CONFIG2L (Configuration 2 Low) .....	260
Specifications .....	351	CONFIG3H (Configuration 3 High) .....	262
Precision Internal Oscillator Parameters .....	349	CONFIG4L (Configuration 4 Low) .....	262
Prescaler, Timer0 .....	97	CONFIG5H (Configuration 5 High) .....	263
PRI_IDLE Mode .....	232	CONFIG5L (Configuration 5 Low) .....	263
PRI_RUN Mode .....	230	CONFIG6H (Configuration 6 High) .....	264
Program Counter .....	26	CONFIG6L (Configuration 6 Low) .....	264
PCL, PCH and PCU Registers .....	26	CONFIG7H (Configuration 7 High) .....	265
PCLATH and PCLATU Registers .....	26	CONFIG7L (Configuration 7 Low) .....	265
Program Memory		DEVID1 (Device ID 1) .....	266
and Extended Instruction Set .....	45	DEVID2 (Device ID 2) .....	266
Code Protection .....	270	ECCPAS (Enhanced CCP Auto-shutdown Control) .	123
Instructions .....	30	EECON1 (Data EEPROM Control 1) .....	49, 58
Two-Word .....	30	INTCON (Interrupt Control) .....	65
Interrupt Vector .....	25	INTCON2 (Interrupt Control 2) .....	66
Look-up Tables .....	28	INTCON3 (Interrupt Control 3) .....	67
Map and Stack (diagram) .....	25	IOCA (Interrupt-on-Change PORTA) .....	80
Reset Vector .....	25	IOCB (Interrupt-on-Change PORTB) .....	85
Program Verification and Code Protection .....	268	IPR1 (Peripheral Interrupt Priority 1) .....	72
Associated Registers .....	270	IPR2 (Peripheral Interrupt Priority 2) .....	73
Programming, Device Instructions .....	273	LATA (PORTA Data Latch) .....	80
PSTRCON Register .....	128	LATB (PORTB Data Latch) .....	84
Pulse Steering .....	128	LATC (PORTC Data Latch) .....	89
PUSH .....	302	OSCCON (Oscillator Control) .....	18, 19
PUSH and POP Instructions .....	27	OSCTUNE (Oscillator Tuning) .....	20
PUSHL .....	318	PIE1 (Peripheral Interrupt Enable 1) .....	70
PWM (ECCP Module)		PIE2 (Peripheral Interrupt Enable 2) .....	71
Effects of a Reset .....	131	PIR1 (Peripheral Interrupt Request 1) .....	68
Operation in Power Managed Modes .....	131	PIR2 (Peripheral Interrupt Request 2) .....	69
Operation with Fail-Safe Clock Monitor .....	131	PORTA .....	79
Pulse Steering .....	128	PORTB .....	84, 88
Steering Synchronization .....	130	PSTRCON (Pulse Steering Control) .....	128
PWM Mode. See Enhanced Capture/Compare/PWM .....	115	PWM1CON (Enhanced PWM Control) .....	127
PWM1CON Register .....	127	RCON (Reset Control) .....	74, 246
		RCSTA (Receive Status and Control) .....	185
<b>R</b>		SLRCON (PORT Slew Rate Control) .....	94
RAM. See Data Memory.		SRCON0 (SR Latch Control 0) .....	236
RC_IDLE Mode .....	233	SRCON1 (SR Latch Control 1) .....	237
RC_RUN Mode .....	230	SSPADD (MSSP Address and Baud Rate,	
RCALL .....	303	SPI Mode) .....	153
RCON Register .....	74, 246	SSPCON1 (MSSP Control 1, I <sup>2</sup> C Mode) .....	144
Bit Status During Initialization .....	252	SSPCON1 (MSSP Control 1, SPI Mode) .....	135
RCREG .....	182	SSPCON2 (MSSP Control 2, I <sup>2</sup> C Mode) .....	145
RCSTA Register .....	185	SSPMSK (SSP Mask) .....	152
Reader Response .....	402	SSPSTAT (MSSP Status, SPI Mode) .....	134, 143
Register		STATUS .....	40
RCREG Register .....	191	STKPTR (Stack Pointer) .....	27
Register File .....	35	T0CON (Timer0 Control) .....	95
Register File Summary .....	37	T1CON (Timer1 Control) .....	99
Registers		T2CON (Timer2 Control) .....	105
ADCON0 (ADC Control 0) .....	209	T3CON (Timer3 Control) .....	107
ADCON1 (ADC Control 1) .....	210, 211	TRISA (Tri-State PORTA) .....	79
ADRESH (ADC Result High) with ADFM = 0) .....	212	TRISB (Tri-State PORTB) .....	84, 88
ADRESH (ADC Result High) with ADFM = 1) .....	212	TXSTA (Transmit Status and Control) .....	184
ADRESL (ADC Result Low) with ADFM = 0) .....	212	VREFCON0 .....	241
ADRESL (ADC Result Low) with ADFM = 1) .....	212	VREFCON1 .....	242
ANSEL (Analog Select) .....	92		

# PIC18(L)F1XK22

VRECON2 .....	242	SR Latch .....	235
WDTCN (Watchdog Timer Control) .....	268	Associated Registers .....	237
WPUA (Weak Pull-up PORTA) .....	80	SRCON0 Register .....	236
WPUB (Weak Pull-up PORTB) .....	85	SRCON1 Register .....	237
RESET .....	303	SS .....	133
Reset State of Registers .....	252	SSP	
Resets .....	245, 257	Typical SPI Master/Slave Connection .....	137
Brown-out Reset (BOR) .....	257	SSPADD Register .....	153
Oscillator Start-up Timer (OST) .....	257	SSPCON1 Register .....	135, 144
Power-on Reset (POR) .....	257	SSPCON2 Register .....	145
Power-up Timer (PWRT) .....	257	SSPMSK Register .....	152
RETFIE .....	304	SSPOV .....	165
RETLW .....	304	SSPOV Status Flag .....	165
RETURN .....	305	SSPSTAT Register .....	134, 143
Return Address Stack .....	26	R/W Bit .....	146, 147
Return Stack Pointer (STKPTR) .....	27	Stack Full/Underflow Resets .....	28
Revision History .....	389	Standard Instructions .....	273
RLCF .....	305	STATUS Register .....	40
RLNCF .....	306	STKPTR Register .....	27
RRCF .....	306	SUBFSR .....	319
RRNCF .....	307	SUBFWB .....	308
<b>S</b>		SUBLW .....	309
SCK .....	133	SUBULNK .....	319
SDI .....	133	SUBWF .....	309
SDO .....	133	SUBWFB .....	310
SEC_IDLE Mode .....	232	SWAPF .....	310
SEC_RUN Mode .....	230	<b>T</b>	
Serial Clock, SCK .....	133	T0CON Register .....	95
Serial Data In (SDI) .....	133	T1CON Register .....	99
Serial Data Out (SDO) .....	133	T2CON Register .....	105
Serial Peripheral Interface. <i>See</i> SPI Mode.		T3CON Register .....	107
SETF .....	307	Table Pointer Operations (table) .....	50
Shoot-through Current .....	126	Table Reads/Table Writes .....	28
Single-Supply ICSP Programming.		TBLRD .....	311
Slave Select (SS) .....	133	TBLWT .....	312
Slave Select Synchronization .....	139	Thermal Considerations .....	344
SLEEP .....	308	Time-out in Various Situations (table) .....	249
Sleep Mode .....	231	Timer0 .....	95
SLRCON Register .....	94	Associated Registers .....	97
Software Simulator (MPLAB SIM) .....	325	Operation .....	96
SPBRG .....	187	Overflow Interrupt .....	97
SPBRGH .....	187	Prescaler .....	97
Special Event Trigger .....	207	Prescaler Assignment (PSA Bit) .....	97
Special Event Trigger. <i>See</i> Compare (ECCP Mode).		Prescaler Select (TOPS2:TOPS0 Bits) .....	97
Special Features of the CPU .....	257	Prescaler. <i>See</i> Prescaler, Timer0.	
Special Function Registers .....	35	Reads and Writes in 16-Bit Mode .....	96
Map .....	36	Source Edge Select (T0SE Bit) .....	96
SPI Mode		Source Select (T0CS Bit) .....	96
Typical Master/Slave Connection .....	137	Specifications .....	352
SPI Mode (MSSP)		Switching Prescaler Assignment .....	97
Associated Registers .....	141	Timer1 .....	99
Bus Mode Compatibility .....	141	16-Bit Read/Write Mode .....	102
Effects of a Reset .....	141	Associated Registers .....	104
Enabling SPI I/O .....	137	Interrupt .....	103
Master Mode .....	138	Modes of Operation .....	102
Operation .....	136	Operation .....	100
Operation in Power Managed Modes .....	141	Oscillator .....	99, 102
Serial Clock .....	133	Overflow Interrupt .....	99
Serial Data In .....	133	Resetting, Using the CCP Special Event Trigger .....	103
Serial Data Out .....	133	Specifications .....	352
Slave Mode .....	139	TMR1H Register .....	99
Slave Select .....	133	TMR1L Register .....	99
Slave Select Synchronization .....	139	Use as a Real-Time Clock .....	103
SPI Clock .....	138	Timer2 .....	105
Typical Connection .....	137	Associated Registers .....	106

# PIC18(L)F1XK22

Interrupt.....	106	Repeat Start Condition .....	164
Operation .....	105	Reset, WDT, OST and Power-up Timer .....	350
Output .....	106	Send Break Character Sequence .....	194
Timer3 .....	107	Slave Synchronization .....	139
16-Bit Read/Write Mode.....	110	Slow Rise Time (MCLR Tied to VDD, VDD Rise > TPWRT) .....	251
Associated Registers .....	110	SPI Master Mode (CKE = 1, SMP = 1) .....	357
Operation .....	108	SPI Mode (Master Mode).....	138
Oscillator .....	107, 110	SPI Mode (Slave Mode, CKE = 0).....	140
Overflow Interrupt .....	107, 110	SPI Mode (Slave Mode, CKE = 1).....	140
Special Event Trigger (CCP).....	110	SPI Slave Mode (CKE = 0).....	358
TMR3H Register .....	107	SPI Slave Mode (CKE = 1).....	358
TMR3L Register .....	107	Synchronous Reception (Master Mode, SREN) .....	198
Timing Diagrams		Synchronous Transmission .....	196
A/D Conversion .....	354	Synchronous Transmission (Through TXEN).....	196
Acknowledge Sequence .....	168	Time-out Sequence on POR w/PLL Enabled (MCLR Tied to VDD) .....	251
Asynchronous Reception .....	182	Time-out Sequence on Power-up (MCLR Not Tied to VDD, Case 1) .....	250
Asynchronous Transmission .....	178	Time-out Sequence on Power-up (MCLR Not Tied to VDD, Case 2).....	250
Asynchronous Transmission (Back to Back) .....	179	Time-out Sequence on Power-up (MCLR Tied to VDD, VDD Rise < TPWRT) .....	250
Auto Wake-up Bit (WUE) During Normal Operation ..	193	Timer0 and Timer1 External Clock .....	352
Auto Wake-up Bit (WUE) During Sleep .....	193	Transition for Entry to Sleep Mode .....	231
Automatic Baud Rate Calculator .....	191	Transition for Wake from Sleep (HSPLL) .....	231
Baud Rate Generator with Clock Arbitration .....	162	Transition Timing for Entry to Idle Mode.....	232
BRG Reset Due to SDA Arbitration During Start Condition .....	171	Transition Timing for Wake from Idle to Run Mode ..	232
Brown-out Reset (BOR) .....	350	USART Synchronous Receive (Master/Slave) .....	356
Bus Collision During a Repeated Start Condition (Case 1) .....	172	USART Synchronous Transmission (Master/Slave) ..	356
Bus Collision During a Repeated Start Condition (Case 2) .....	172	Timing Diagrams and Specifications	
Bus Collision During a Start Condition (SCL = 0) .....	171	A/D Conversion Requirements .....	354
Bus Collision During a Stop Condition (Case 1) .....	173	External Clock Requirements .....	347
Bus Collision During a Stop Condition (Case 2) .....	173	PLL Clock .....	348
Bus Collision During Start Condition (SDA only) .....	170	Timing Parameter Symbology .....	345
Bus Collision for Transmit and Acknowledge.....	169	Timing Requirements	
CLKOUT and I/O.....	349	I <sup>2</sup> C Bus Data.....	361
Clock Synchronization .....	155	I <sup>2</sup> C Bus Start/Stop Bits .....	360
Clock Timing .....	346	SPI Mode .....	359
Clock/Instruction Cycle .....	29	Top-of-Stack Access.....	26
Comparator Output .....	217	TRISA Register .....	79
Enhanced Capture/Compare/PWM (ECCP) .....	353	TRISB Register .....	84, 88
Fail-Safe Clock Monitor (FSCM) .....	24	TSTFSZ .....	313
First Start Bit Timing .....	163	Two-Speed Start-up.....	257
Full-Bridge PWM Output .....	120	Two-Word Instructions	
Half-Bridge PWM Output .....	118, 126	Example Cases.....	30
I <sup>2</sup> C Bus Data .....	360	TXREG .....	177
I <sup>2</sup> C Bus Start/Stop Bits.....	359	TXSTA Register .....	184
I <sup>2</sup> C Master Mode (7 or 10-Bit Transmission) .....	166	BRGH Bit .....	187
I <sup>2</sup> C Master Mode (7-Bit Reception).....	167	<b>U</b>	
I <sup>2</sup> C Slave Mode (10-Bit Reception, SEN = 0) .....	150	USART	
I <sup>2</sup> C Slave Mode (10-Bit Reception, SEN = 1) .....	157	Synchronous Master Mode	
I <sup>2</sup> C Slave Mode (10-Bit Transmission).....	151	Requirements, Synchronous Receive .....	356
I <sup>2</sup> C Slave Mode (7-bit Reception, SEN = 0).....	148	Requirements, Synchronous Transmission .....	356
I <sup>2</sup> C Slave Mode (7-Bit Reception, SEN = 1) .....	156	Timing Diagram, Synchronous Receive .....	356
I <sup>2</sup> C Slave Mode (7-Bit Transmission).....	149	Timing Diagram, Synchronous Transmission ...	356
I <sup>2</sup> C Slave Mode General Call Address Sequence (7 or 10-Bit Address Mode) .....	158	<b>V</b>	
I <sup>2</sup> C Stop Condition Receive or Transmit Mode .....	168	Voltage Reference (VR)	
Internal Oscillator Switch Timing .....	21	Specifications .....	355
PWM Auto-shutdown		Voltage Reference. See Comparator Voltage	
Auto-restart Enabled .....	125	Reference (CVREF)	
Firmware Restart .....	124	Voltage References	
PWM Direction Change .....	121	Fixed Voltage Reference (FVR).....	240
PWM Direction Change at Near 100% Duty Cycle ...	122	VR Stabilization .....	240
PWM Output (Active-High).....	116		
PWM Output (Active-Low) .....	117		

VRECON0 (Voltage Reference Control 0) Register .....	241
VRECON1 (Voltage Reference Control 1) Register .....	242
VRECON2 (Voltage Reference Control 2) Register .....	242
VREF. <i>SEE</i> ADC Reference Voltage	

## W

Wake-up on Break .....	192
Watchdog Timer (WDT) .....	257, 267
Associated Registers .....	268
Control Register .....	268
Programming Considerations .....	267
Specifications .....	351
WCOL .....	163, 164, 165, 168
WCOL Status Flag .....	163, 164, 165, 168
WDTCON Register .....	268
WPUA Register .....	80
WPUB Register .....	85
WWW Address .....	401
WWW, On-Line Support .....	6

## X

XORLW .....	313
XORWF .....	314

# PIC18(L)F1XK22

---

NOTES:



## THE MICROCHIP WEB SITE

Microchip provides online support via our WWW site at [www.microchip.com](http://www.microchip.com). This web site is used as a means to make files and information easily available to customers. Accessible by using your favorite Internet browser, the web site contains the following information:

- **Product Support** – Data sheets and errata, application notes and sample programs, design resources, user's guides and hardware support documents, latest software releases and archived software
- **General Technical Support** – Frequently Asked Questions (FAQ), technical support requests, online discussion groups, Microchip consultant program member listing
- **Business of Microchip** – Product selector and ordering guides, latest Microchip press releases, listing of seminars and events, listings of Microchip sales offices, distributors and factory representatives

## CUSTOMER CHANGE NOTIFICATION SERVICE

Microchip's customer notification service helps keep customers current on Microchip products. Subscribers will receive e-mail notification whenever there are changes, updates, revisions or errata related to a specified product family or development tool of interest.

To register, access the Microchip web site at [www.microchip.com](http://www.microchip.com). Under "Support", click on "Customer Change Notification" and follow the registration instructions.

## CUSTOMER SUPPORT

Users of Microchip products can receive assistance through several channels:

- Distributor or Representative
- Local Sales Office
- Field Application Engineer (FAE)
- Technical Support
- Development Systems Information Line

Customers should contact their distributor, representative or field application engineer (FAE) for support. Local sales offices are also available to help customers. A listing of sales offices and locations is included in the back of this document.

**Technical support is available through the web site at: <http://microchip.com/support>**

# PIC18(L)F1XK22

---

---

## READER RESPONSE

It is our intention to provide you with the best documentation possible to ensure successful use of your Microchip product. If you wish to provide your comments on organization, clarity, subject matter, and ways in which our documentation can better serve you, please FAX your comments to the Technical Publications Manager at (480) 792-4150.

Please list the following information, and use this outline to provide us with your comments about this document.

TO: Technical Publications Manager Total Pages Sent \_\_\_\_\_

RE: Reader Response

From: Name \_\_\_\_\_

Company \_\_\_\_\_

Address \_\_\_\_\_

City / State / ZIP / Country \_\_\_\_\_

Telephone: (\_\_\_\_\_) \_\_\_\_\_ - \_\_\_\_\_ FAX: (\_\_\_\_\_) \_\_\_\_\_ - \_\_\_\_\_

Application (optional):

Would you like a reply?  Y  N

Device: PIC18(L)F1XK22

Literature Number: DS41365E

Questions:

1. What are the best features of this document?

---

---

2. How does this document meet your hardware and software development needs?

---

---

3. Do you find the organization of this document easy to follow? If not, why?

---

---

4. What additions to the document do you think would enhance the structure and subject?

---

---

5. What deletions from the document could be made without affecting the overall usefulness?

---

---

6. Is there any incorrect or misleading information (what and where)?

---

---

7. How would you improve this document?

---

---

## PRODUCT IDENTIFICATION SYSTEM

To order or obtain information, e.g., on pricing or delivery, refer to the factory or the listed sales office.

<u>PART NO.</u>	<u>X<sup>(2)</sup></u>	<u>X</u>	<u>/XX</u>	<u>XXX</u>																																																													
Device	Tape and Reel Option	Temperature Range	Package	Pattern																																																													
<table border="1"> <tr> <td><b>Device:</b></td> <td colspan="5">PIC18F13K22, PIC18LF13K22 PIC18F14K22, PIC18LF14K22</td> </tr> <tr> <td><b>Tape and Reel:</b></td> <td colspan="5"><b>blank</b> = standard packaging (tube and tray)</td> </tr> <tr> <td><b>Option:</b></td> <td colspan="5">T = Tape and Reel<sup>(1), (2)</sup></td> </tr> <tr> <td><b>Temperature Range:</b></td> <td>E</td> <td>= -40°C to +125°C</td> <td colspan="3">(Extended)</td> </tr> <tr> <td></td> <td>I</td> <td>= -40°C to +85°C</td> <td colspan="3">(Industrial)</td> </tr> <tr> <td><b>Package:</b></td> <td>ML</td> <td>=</td> <td colspan="3">QFN</td> </tr> <tr> <td></td> <td>P</td> <td>=</td> <td colspan="3">PDIP</td> </tr> <tr> <td></td> <td>SO</td> <td>=</td> <td colspan="3">SOIC</td> </tr> <tr> <td></td> <td>SS</td> <td>=</td> <td colspan="3">SSOP</td> </tr> <tr> <td><b>Pattern:</b></td> <td colspan="5">QTP, SQTP, Code or Special Requirements (blank otherwise)</td> </tr> </table>						<b>Device:</b>	PIC18F13K22, PIC18LF13K22 PIC18F14K22, PIC18LF14K22					<b>Tape and Reel:</b>	<b>blank</b> = standard packaging (tube and tray)					<b>Option:</b>	T = Tape and Reel <sup>(1), (2)</sup>					<b>Temperature Range:</b>	E	= -40°C to +125°C	(Extended)				I	= -40°C to +85°C	(Industrial)			<b>Package:</b>	ML	=	QFN				P	=	PDIP				SO	=	SOIC				SS	=	SSOP			<b>Pattern:</b>	QTP, SQTP, Code or Special Requirements (blank otherwise)				
<b>Device:</b>	PIC18F13K22, PIC18LF13K22 PIC18F14K22, PIC18LF14K22																																																																
<b>Tape and Reel:</b>	<b>blank</b> = standard packaging (tube and tray)																																																																
<b>Option:</b>	T = Tape and Reel <sup>(1), (2)</sup>																																																																
<b>Temperature Range:</b>	E	= -40°C to +125°C	(Extended)																																																														
	I	= -40°C to +85°C	(Industrial)																																																														
<b>Package:</b>	ML	=	QFN																																																														
	P	=	PDIP																																																														
	SO	=	SOIC																																																														
	SS	=	SSOP																																																														
<b>Pattern:</b>	QTP, SQTP, Code or Special Requirements (blank otherwise)																																																																
<p><b>Examples:</b></p> <ul style="list-style-type: none"> <li>a) PIC18F14K22-E/P 301 = Extended temp., PDIP package, QTP pattern #301.</li> <li>b) PIC18LF14K22-E/SO = Extended temp., SOIC package.</li> <li>c) PIC18LF14K22-E/ML = Extended temp., QFN package.</li> <li>d) PIC18F13K22T-I/SS = Industrial temp., SSOP package, Tape and Reel.</li> </ul>																																																																	
<p><b>Note 1:</b> Tape and Reel option is available for ML, SO and SS packages with industrial Temperature Range only.</p> <p><b>2:</b> Tape and Reel identifier only appears in catalog part number description. This identifier is used for ordering purposes and is not printed on the device package.</p>																																																																	



# MICROCHIP

## Worldwide Sales and Service

### AMERICAS

**Corporate Office**  
2355 West Chandler Blvd.  
Chandler, AZ 85224-6199  
Tel: 480-792-7200  
Fax: 480-792-7277  
Technical Support:  
<http://www.microchip.com/support>  
Web Address:  
[www.microchip.com](http://www.microchip.com)

**Atlanta**  
Duluth, GA  
Tel: 678-957-9614  
Fax: 678-957-1455

**Boston**  
Westborough, MA  
Tel: 774-760-0087  
Fax: 774-760-0088

**Chicago**  
Itasca, IL  
Tel: 630-285-0071  
Fax: 630-285-0075

**Cleveland**  
Independence, OH  
Tel: 216-447-0464  
Fax: 216-447-0643

**Dallas**  
Addison, TX  
Tel: 972-818-7423  
Fax: 972-818-2924

**Detroit**  
Farmington Hills, MI  
Tel: 248-538-2250  
Fax: 248-538-2260

**Indianapolis**  
Noblesville, IN  
Tel: 317-773-8323  
Fax: 317-773-5453

**Los Angeles**  
Mission Viejo, CA  
Tel: 949-462-9523  
Fax: 949-462-9608

**Santa Clara**  
Santa Clara, CA  
Tel: 408-961-6444  
Fax: 408-961-6445

**Toronto**  
Mississauga, Ontario,  
Canada  
Tel: 905-673-0699  
Fax: 905-673-6509

### ASIA/PACIFIC

**Asia Pacific Office**  
Suites 3707-14, 37th Floor  
Tower 6, The Gateway  
Harbour City, Kowloon  
Hong Kong  
Tel: 852-2401-1200  
Fax: 852-2401-3431

**Australia - Sydney**  
Tel: 61-2-9868-6733  
Fax: 61-2-9868-6755

**China - Beijing**  
Tel: 86-10-8569-7000  
Fax: 86-10-8528-2104

**China - Chengdu**  
Tel: 86-28-8665-5511  
Fax: 86-28-8665-7889

**China - Chongqing**  
Tel: 86-23-8980-9588  
Fax: 86-23-8980-9500

**China - Hangzhou**  
Tel: 86-571-2819-3187  
Fax: 86-571-2819-3189

**China - Hong Kong SAR**  
Tel: 852-2401-1200  
Fax: 852-2401-3431

**China - Nanjing**  
Tel: 86-25-8473-2460  
Fax: 86-25-8473-2470

**China - Qingdao**  
Tel: 86-532-8502-7355  
Fax: 86-532-8502-7205

**China - Shanghai**  
Tel: 86-21-5407-5533  
Fax: 86-21-5407-5066

**China - Shenyang**  
Tel: 86-24-2334-2829  
Fax: 86-24-2334-2393

**China - Shenzhen**  
Tel: 86-755-8203-2660  
Fax: 86-755-8203-1760

**China - Wuhan**  
Tel: 86-27-5980-5300  
Fax: 86-27-5980-5118

**China - Xian**  
Tel: 86-29-8833-7252  
Fax: 86-29-8833-7256

**China - Xiamen**  
Tel: 86-592-2388138  
Fax: 86-592-2388130

**China - Zhuhai**  
Tel: 86-756-3210040  
Fax: 86-756-3210049

### ASIA/PACIFIC

**India - Bangalore**  
Tel: 91-80-3090-4444  
Fax: 91-80-3090-4123

**India - New Delhi**  
Tel: 91-11-4160-8631  
Fax: 91-11-4160-8632

**India - Pune**  
Tel: 91-20-2566-1512  
Fax: 91-20-2566-1513

**Japan - Yokohama**  
Tel: 81-45-471- 6166  
Fax: 81-45-471-6122

**Korea - Daegu**  
Tel: 82-53-744-4301  
Fax: 82-53-744-4302

**Korea - Seoul**  
Tel: 82-2-554-7200  
Fax: 82-2-558-5932 or  
82-2-558-5934

**Malaysia - Kuala Lumpur**  
Tel: 60-3-6201-9857  
Fax: 60-3-6201-9859

**Malaysia - Penang**  
Tel: 60-4-227-8870  
Fax: 60-4-227-4068

**Philippines - Manila**  
Tel: 63-2-634-9065  
Fax: 63-2-634-9069

**Singapore**  
Tel: 65-6334-8870  
Fax: 65-6334-8850

**Taiwan - Hsin Chu**  
Tel: 886-3-5778-366  
Fax: 886-3-5770-955

**Taiwan - Kaohsiung**  
Tel: 886-7-536-4818  
Fax: 886-7-330-9305

**Taiwan - Taipei**  
Tel: 886-2-2500-6610  
Fax: 886-2-2508-0102

**Thailand - Bangkok**  
Tel: 66-2-694-1351  
Fax: 66-2-694-1350

### EUROPE

**Austria - Wels**  
Tel: 43-7242-2244-39  
Fax: 43-7242-2244-393

**Denmark - Copenhagen**  
Tel: 45-4450-2828  
Fax: 45-4485-2829

**France - Paris**  
Tel: 33-1-69-53-63-20  
Fax: 33-1-69-30-90-79

**Germany - Munich**  
Tel: 49-89-627-144-0  
Fax: 49-89-627-144-44

**Italy - Milan**  
Tel: 39-0331-742611  
Fax: 39-0331-466781

**Netherlands - Drunen**  
Tel: 31-416-690399  
Fax: 31-416-690340

**Spain - Madrid**  
Tel: 34-91-708-08-90  
Fax: 34-91-708-08-91

**UK - Wokingham**  
Tel: 44-118-921-5869  
Fax: 44-118-921-5820

08/02/11