



MICROCHIP

MRF89XAM9A
Data Sheet

915 MHz Ultra Low-Power Sub-GHz
Transceiver Module

Note the following details of the code protection feature on Microchip devices:

- Microchip products meet the specification contained in their particular Microchip Data Sheet.
- Microchip believes that its family of products is one of the most secure families of its kind on the market today, when used in the intended manner and under normal conditions.
- There are dishonest and possibly illegal methods used to breach the code protection feature. All of these methods, to our knowledge, require using the Microchip products in a manner outside the operating specifications contained in Microchip's Data Sheets. Most likely, the person doing so is engaged in theft of intellectual property.
- Microchip is willing to work with the customer who is concerned about the integrity of their code.
- Neither Microchip nor any other semiconductor manufacturer can guarantee the security of their code. Code protection does not mean that we are guaranteeing the product as "unbreakable."

Code protection is constantly evolving. We at Microchip are committed to continuously improving the code protection features of our products. Attempts to break Microchip's code protection feature may be a violation of the Digital Millennium Copyright Act. If such acts allow unauthorized access to your software or other copyrighted work, you may have a right to sue for relief under that Act.

Information contained in this publication regarding device applications and the like is provided only for your convenience and may be superseded by updates. It is your responsibility to ensure that your application meets with your specifications. MICROCHIP MAKES NO REPRESENTATIONS OR WARRANTIES OF ANY KIND WHETHER EXPRESS OR IMPLIED, WRITTEN OR ORAL, STATUTORY OR OTHERWISE, RELATED TO THE INFORMATION, INCLUDING BUT NOT LIMITED TO ITS CONDITION, QUALITY, PERFORMANCE, MERCHANTABILITY OR FITNESS FOR PURPOSE. Microchip disclaims all liability arising from this information and its use. Use of Microchip devices in life support and/or safety applications is entirely at the buyer's risk, and the buyer agrees to defend, indemnify and hold harmless Microchip from any and all damages, claims, suits, or expenses resulting from such use. No licenses are conveyed, implicitly or otherwise, under any Microchip intellectual property rights.

Trademarks

The Microchip name and logo, the Microchip logo, dsPIC, KEELOQ, KEELOQ logo, MPLAB, PIC, PICmicro, PICSTART, PIC³² logo, rPIC and UNI/O are registered trademarks of Microchip Technology Incorporated in the U.S.A. and other countries.

FilterLab, Hampshire, HI-TECH C, Linear Active Thermistor, MXDEV, MXLAB, SEEVAL and The Embedded Control Solutions Company are registered trademarks of Microchip Technology Incorporated in the U.S.A.

Analog-for-the-Digital Age, Application Maestro, chipKIT, chipKIT logo, CodeGuard, dsPICDEM, dsPICDEM.net, dsPICworks, dsSPEAK, ECAN, ECONOMONITOR, FanSense, HI-TIDE, In-Circuit Serial Programming, ICSP, Mindi, MiWi, MPASM, MPLAB Certified logo, MPLIB, MPLINK, mTouch, Omniclient Code Generation, PICC, PICC-18, PICDEM, PICDEM.net, PICKit, PICtail, REAL ICE, rLAB, Select Mode, Total Endurance, TSHARC, UniWinDriver, WiperLock and ZENA are trademarks of Microchip Technology Incorporated in the U.S.A. and other countries.

SQTP is a service mark of Microchip Technology Incorporated in the U.S.A.

All other trademarks mentioned herein are property of their respective companies.

© 2011, Microchip Technology Incorporated, Printed in the U.S.A., All Rights Reserved.

 Printed on recycled paper.

ISBN: 978-1-61341-343-2

Microchip received ISO/TS-16949:2002 certification for its worldwide headquarters, design and wafer fabrication facilities in Chandler and Tempe, Arizona; Gresham, Oregon and design centers in California and India. The Company's quality system processes and procedures are for its PIC[®] MCUs and dsPIC[®] DSCs, KEELOQ[®] code hopping devices, Serial EEPROMs, microperipherals, nonvolatile memory and analog products. In addition, Microchip's quality system for the design and manufacture of development systems is ISO 9001:2000 certified.

QUALITY MANAGEMENT SYSTEM
CERTIFIED BY DNV
== ISO/TS 16949:2009 ==

915 MHz Ultra Low-Power Sub-GHz Transceiver Module

Features

- Module designed from the MRF89XA Integrated Ultra Low-Power, Sub-GHz Transceiver IC.
- Supports MiWi™ Development Environment Proprietary Wireless Networking Protocols
- 4-Wire Serial Peripheral Interface (SPI) with Interrupts
- Small Size: 0.7" x 1.1" (17.8 mm x 27.9 mm), Surface Mountable – Pin compatible with MRF89XAM8A
- Integrated Crystal, Internal Voltage Regulator, Matching Circuitry and Printed Circuit Board (PCB) Antenna
- Easy Integration into Final Product – Minimize Product Development, Quicker Time to Market
- Compatible with Microchip's Microcontroller Families (PIC16, PIC18, PIC24, dsPIC33 and PIC32)
- Modular Device Approval for United States (FCC), Canada (IC) and Radio Regulation Certified for Australia/New Zealand (C-TICK)

Operational

- Operating Voltage: 2.1–3.6V (3.3V typical)
- Temperature Range: -40°C to +85°C Industrial
- Low-Current Consumption:
 - Rx mode: 3 mA (typical)
 - Tx mode: 25 mA at +10 dBm (typical)
 - Sleep: 0.1 µA (typical)

RF/Analog Features

- ISM Band 902–928 MHz Operation
- Modulation: FSK and OOK
- Data Rate:
 - FSK: 200 kbps
 - OOK: 28 kbps
- Reception sensitivity
 - FSK: -105 dBm (typical) at 25 kbps
 - OOK: -111 dBm (typical) at 2 kbps
- +10 dBm Typical Output Power with 21 dB Tx Power Control Range

Media Access Controller (MAC)/ Baseband Features

- Packet handling feature with data whitening and automatic CRC generation
- Incoming sync word (pattern) recognition
- Built-in bit synchronizer for incoming data, and clock synchronization and recovery
- 64-byte transmit/receive FIFO with preload in Stand-by mode
- Supports Manchester encoding/decoding techniques

Pin diagram

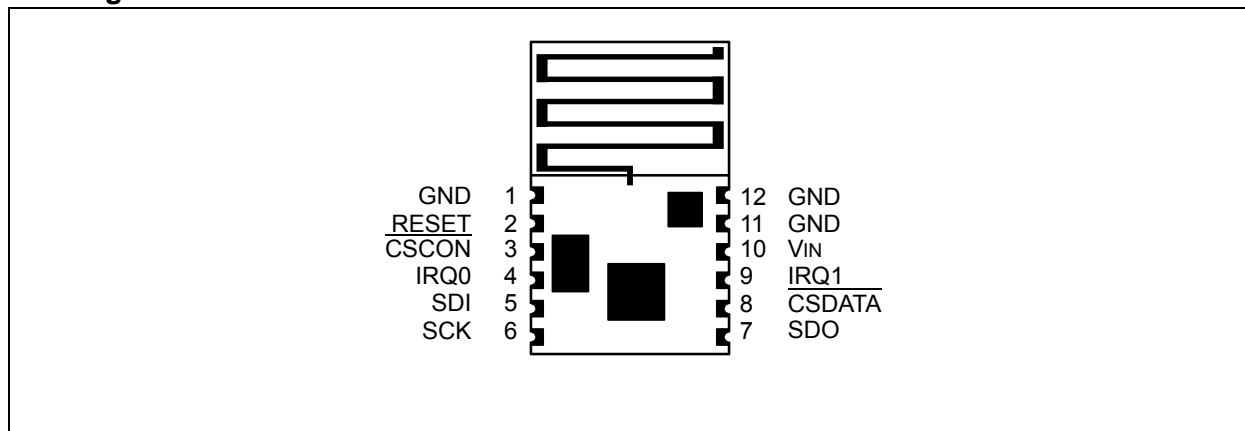

MRF89XAM9A

Table of Contents

1.0 Device Overview	3
2.0 Circuit Description	9
3.0 Regulatory Approval	17
4.0 Electrical Characteristics	21
Appendix A: Revision History	27
The Microchip Web Site	29
Customer Change Notification Service	29
Customer Support	29
Reader Response	30
Product Identification System	31

TO OUR VALUED CUSTOMERS

It is our intention to provide our valued customers with the best documentation possible to ensure successful use of your Microchip products. To this end, we will continue to improve our publications to better suit your needs. Our publications will be refined and enhanced as new volumes and updates are introduced.

If you have any questions or comments regarding this publication, please contact the Marketing Communications Department via E-mail at docerrors@microchip.com or fax the **Reader Response Form** in the back of this data sheet to (480) 792-4150. We welcome your feedback.

Most Current Data Sheet

To obtain the most up-to-date version of this data sheet, please register at our Worldwide Web site at:

<http://www.microchip.com>

You can determine the version of a data sheet by examining its literature number found on the bottom outside corner of any page. The last character of the literature number is the version number, (e.g., DS30000A is version A of document DS30000).

Errata

An errata sheet, describing minor operational differences from the data sheet and recommended workarounds, may exist for current devices. As device/documentation issues become known to us, we will publish an errata sheet. The errata will specify the revision of silicon and revision of document to which it applies.

To determine if an errata sheet exists for a particular device, please check with one of the following:

- Microchip's Worldwide Web site; <http://www.microchip.com>
- Your local Microchip sales office (see last page)

When contacting a sales office, please specify which device, revision of silicon and data sheet (include literature number) you are using.

Customer Notification System

Register on our web site at www.microchip.com to receive the most current information on all of our products.

1.0 DEVICE OVERVIEW

The MRF89XAM9A is an ultra low-power sub-GHz surface mount transceiver module with integrated crystal, internal voltage regulator, matching circuitry and PCB antenna. The MRF89XAM9A module operates in the United States/Canada 902–928 MHz ISM frequency band. The integrated module design frees the integrator from extensive RF and antenna design, and regulatory compliance testing, allowing quicker time to market.

The MRF89XAM9A module is compatible with Microchip's MiWi™ Development Environment software stacks. The software stacks are available as a free download, including source code, from the Microchip's web site <http://www.microchip.com/wireless>.

The MRF89XAM9A module has received regulatory approvals for modular devices in the United States (FCC) and Canada (IC). Modular device approval removes the need for expensive RF and antenna design, and allows the user to place the MRF89XAM9A module inside a finished product and not require regulatory testing for an intentional radiator (RF transmitter). To maintain conformance, refer to module settings in [Section 3.1.1, MRF89XAM9A SETTINGS](#) for the United States and [Section 3.2.1, MRF89XAM9A SETTINGS](#) for Canada.

1.1 Interface description

The simplified block diagram of the MRF89XAM9A module is shown in [Figure 1-1](#). The module is based on the Microchip Technology MRF89XA Ultra Low-Power Sub-GHz Transceiver Integrated Circuit (IC). The module interfaces to many popular Microchip PIC® microcontrollers through a 3-wire serial SPI interface, two chip selects (configuration and data), two interrupts Interrupt Request 0 (IRQ0) and Interrupt Request 1 (IRQ1), Reset, Power and Ground as shown in [Figure 1-2](#). [Table 1-1](#) provides the pin descriptions.

Data communication and module configuration are documented in the “*MRF89XA Ultra Low-Power, Integrated Sub-GHz Transceiver*” (DS70622) Data Sheet. For more information on specific serial interface protocol and general register definitions, refer to the “*MRF89XA Data Sheet*” and see [Section 1.3, Operation](#) for specific register settings unique to the MRF89XAM9A module operation to maintain regulatory compliance.

FIGURE 1-1: MRF89XAM9A BLOCK DIAGRAM

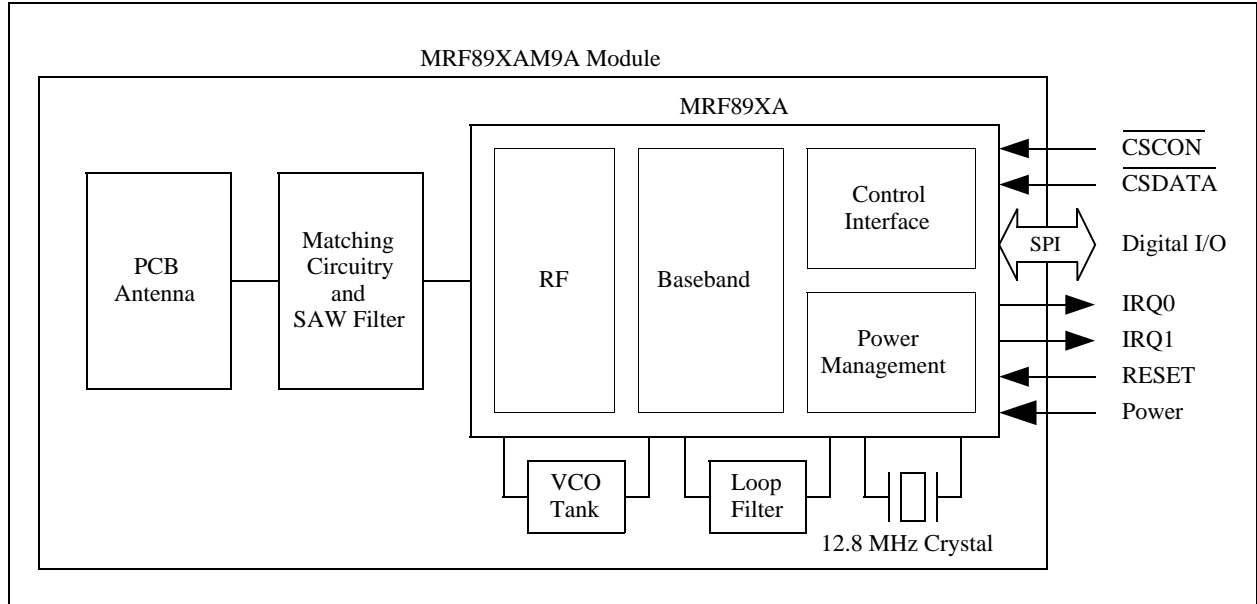

MRF89XAM9A

TABLE 1-1: PIN DESCRIPTION

Pin	Symbol	Type	Description
1	GND	Power	Ground
2	RESET	DI	Reset Pin. For more information, refer to Section 1.3.1, Reset
3	CSCON	DI	Serial Interface Configure Chip Select
4	IRQ0	DO	Interrupt Request Output
5	SDI	DI	Serial Interface Data Input
6	SCK	DI	Serial Interface Clock
7	SDO	DO	Serial Interface Data Output
8	CSDATA	DI	Serial Interface Data Chip Select
9	IRQ1	DO	Interrupt Request Output
10	V _{in}	Power	Power Supply
11	GND	Power	Ground
12	GND	Power	Ground

FIGURE 1-2: MICROCONTROLLER TO MRF89XAM9A INTERFACE

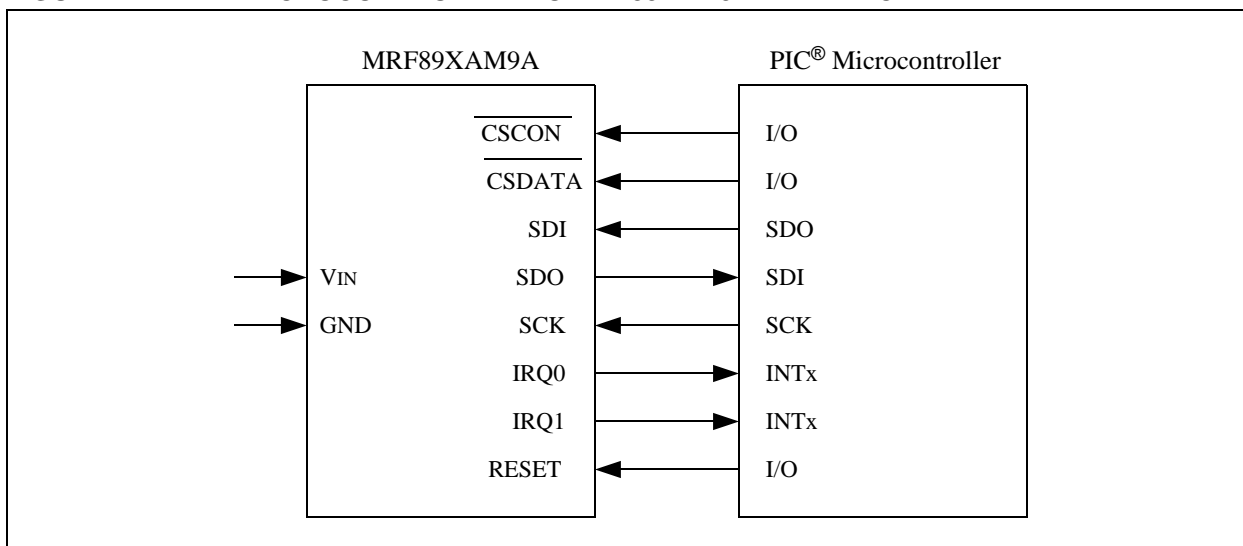

MRF89XAM9A

FIGURE 1-5: MOUNTING DETAILS

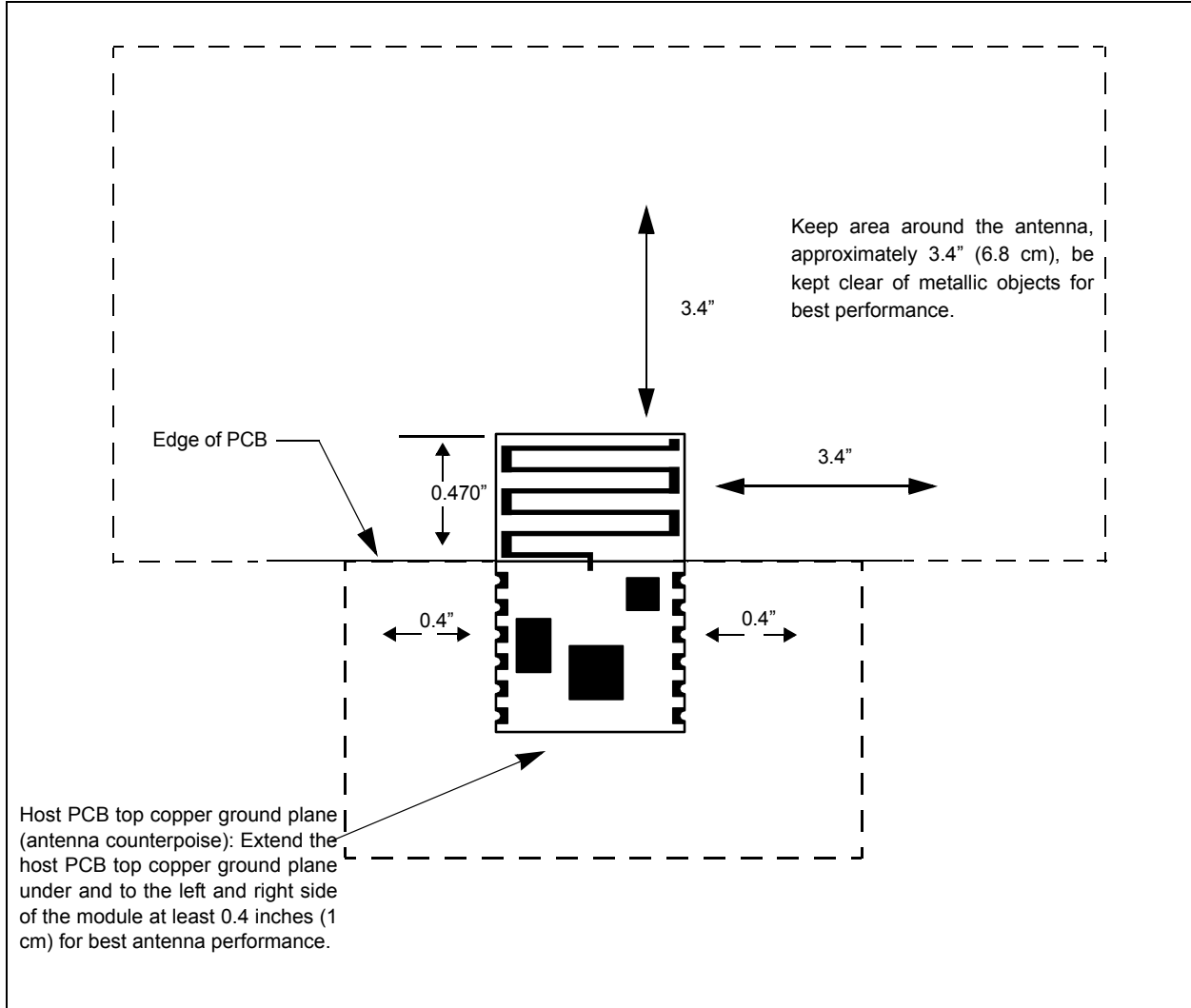

1.3 Operation

The MRF89XAM9A module is based on the Microchip's MRF89XA Ultra Low-Power, Integrated ISM Band Sub-GHz Transceiver IC. Data communication and module configuration are documented in the "*MRF89XA Ultra Low-Power, Integrated ISM Band Sub-GHz Transceiver Data Sheet*" (DS70622).

This section emphasizes operational settings that are unique to the MRF89XAM9A module design that must be followed for proper operation.

1.3.1 RESET

Pin 2 of the module, RESET, allows an external reset of the MRF89XA IC. RESET is connected to the TEST8 pin of the MRF89XA IC. During normal operations of the MRF89XAM9A, the RESET pin should be held in a high impedance state. For more information on assertion of the RESET pin, refer to "*Section 3.1.2 Manual Reset*" in the "*MRF89XA Data Sheet*" (DS70622).

1.3.2 CRYSTAL FREQUENCY

When calculating frequency deviation, bit rate, receiver bandwidth, and PLL R, P and S values, use crystal frequency $f_{xtal} = 12.8$ MHz.

1.3.3 CLOCK OUTPUT (CLKOUT)

The CLKOUT pin 19 of the MRF89XA IC is not used on the module. Ensure that the CLKOUT signal is disabled to minimize current consumption.

1.3.4 FREQUENCY BAND SELECT

The Frequency Band Select (FBS<1:0>) bits in the GCONREG<4:3> should be set for target channel range 902–915 MHz FBS<1:0> = '00' or 915–928 MHz FBS<1:0> = '01'.

1.3.5 VCO TANK TRIM VALUE

The VCO Trim (VCOT<1:0>) bits in the GCONREG<2:1> should be set for VCOT<1:0> = '01' for the inductor values of the module.

1.3.6 BIT RATE

The maximum bit rate value will be limited to 28 kbps for OOK modulation due to the crystal frequency of 12.8 MHz.

MRF89XAM9A

NOTES:

2.0 CIRCUIT DESCRIPTION

The MRF89XAM9A module interfaces to Microchip's PIC16, PIC18, PIC24, dsPIC33 and PIC32 microcontrollers with a minimum of external components through digital only connections. An example application schematic is shown in [Figure 2-2](#).

2.1 Module Schematic

The MRF89XAM9A module is based on the Microchip's MRF89XA Ultra Low-Power, Integrated ISM Band Sub-GHz Transceiver IC. The serial I/O (CSCON, CSDATA, SCK, SDO and SDI), RESET, IRQ0 and IRQ1 pins are routed out and available on the module pins as shown in [Figure 2-2](#). Crystal X1 is a 12.8 MHz crystal with a frequency tolerance of ± 10 ppm at 25°C. The RFIO output is matched to the SAW filter FL1 and further matched to the PCB trace antenna.

[Figure 2-2](#) illustrates the MRF89XAM9A schematics. [Table 2-1](#) details the Bill of Materials (BOM).

FIGURE 2-1: MRF89XAM9A APPLICATION SCHEMATIC

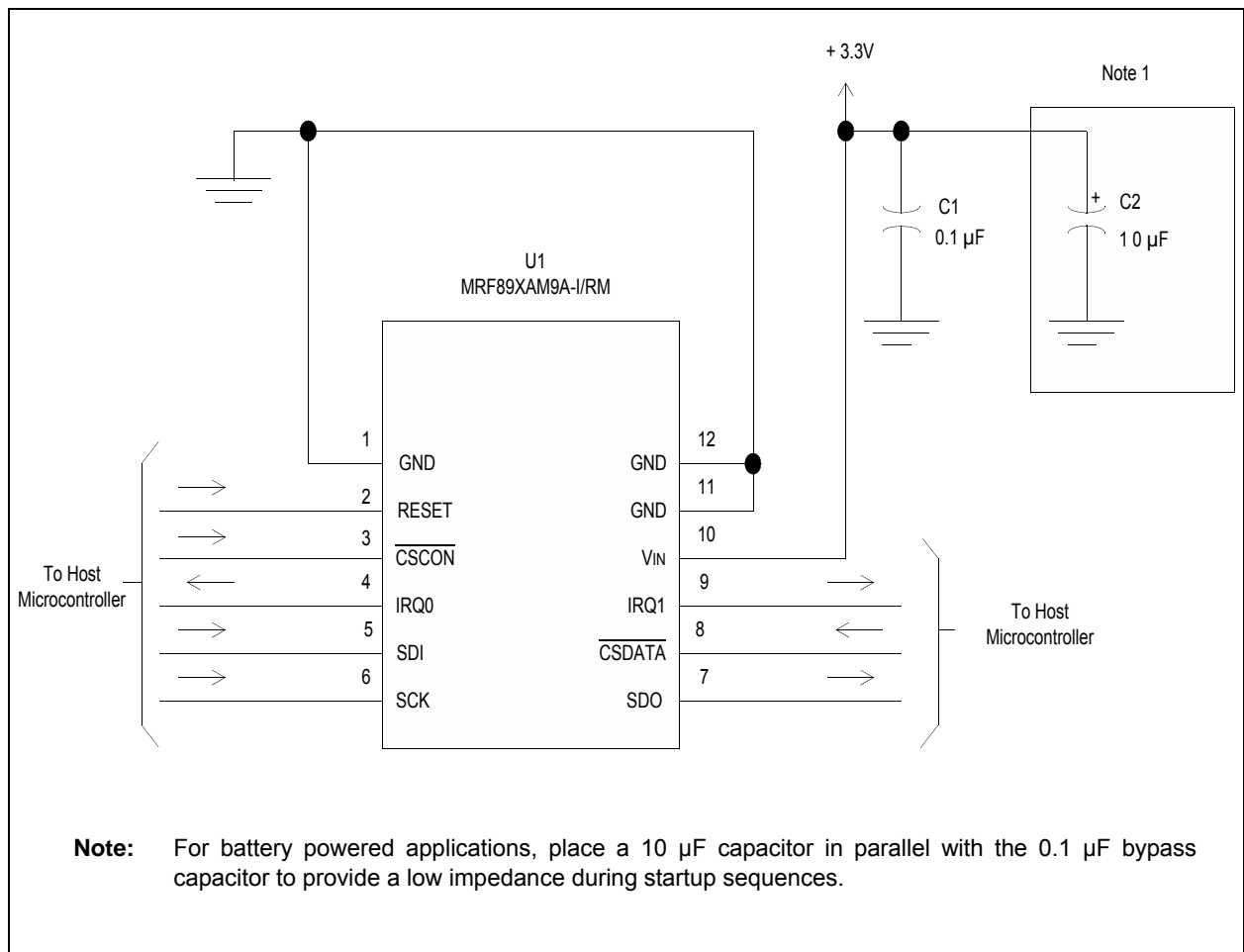

MRF89XAM9A

FIGURE 2-2: MRF89XAM9A SCHEMATIC

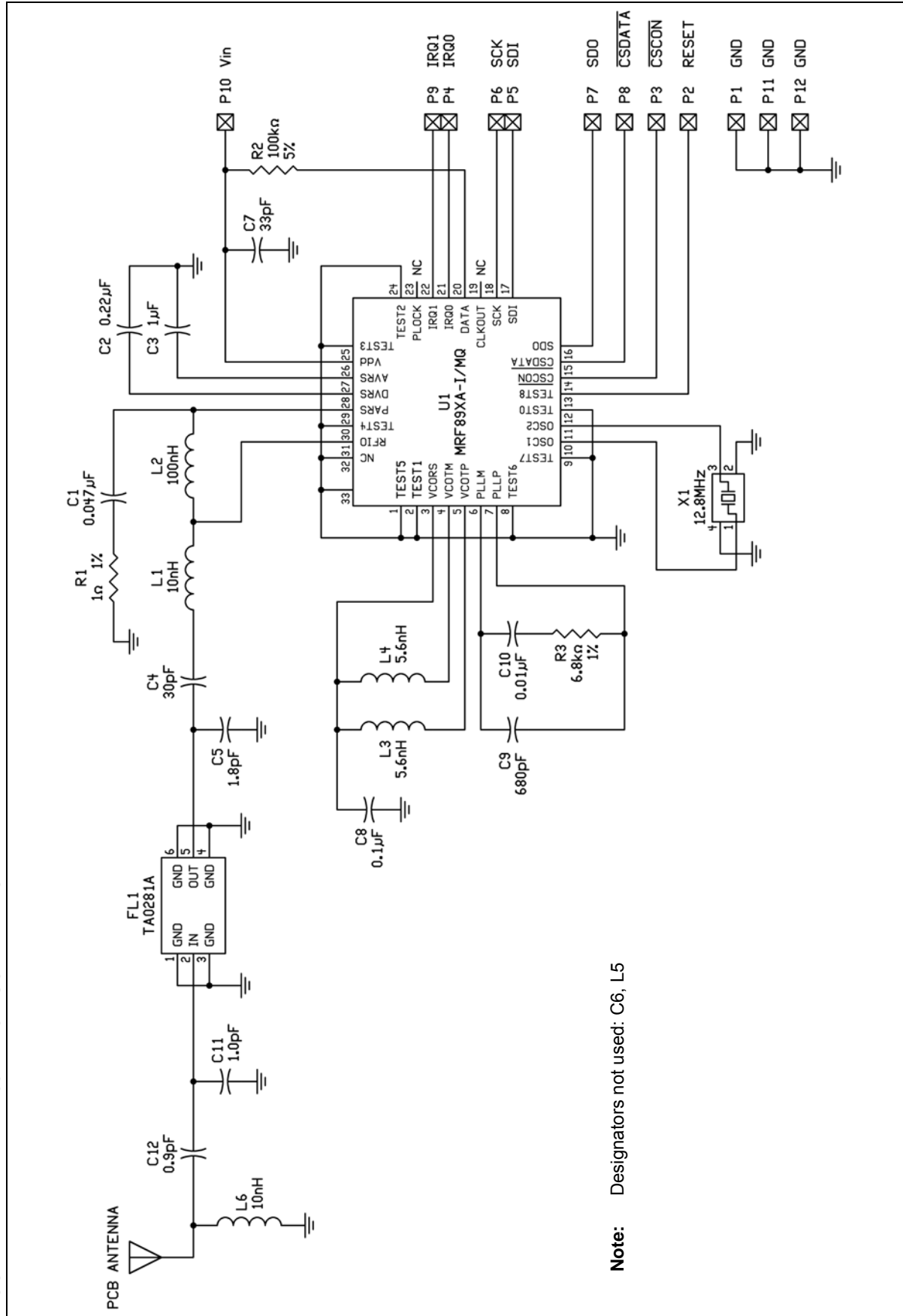

Note: Designators not used: C6, L5

MRF89XAM9A

TABLE 2-1: MRF89XAM9A BILL OF MATERIALS

Designator	Value	Description	Manufacturer	Part Number
C1	0.047 μ F	Capacitor, Ceramic, 10V, \pm 10%, X7R, SMT 0402	Murata	GRM155R71A473KA01D
C2	0.22 μ F	Capacitor, Ceramic, 16V, \pm 10%, X7R, SMT 0402	Murata	GRM155R71C224KA12D
C3	1 μ F	Capacitor, Ceramic, 6.3V, \pm 10%, X5R, SMT 0603	Murata	GRM188R60J105KA01D
C4	30 pF	Capacitor, Ceramic, 50V, \pm 5%, UHI-Q NP0, SMT 0402	Johanson Technology	250R07S300JV4T
C5	1.8 pF	Capacitor, Ceramic, 50V, \pm 0.1 pF, UHI-Q NP0, SMT 0402	Johanson Technology	500R07S1R8BV4
C6	—	Designator not used	—	—
C7	33 pF	Capacitor, Ceramic, 50V, \pm 5%, C0G, SMT 0402	Murata	GRM1555C1H330JZ01D
C8	0.1 μ F	Capacitor, Ceramic, 16V, \pm 10%, X7R, SMT 0402	Murata	GRM155R71C104KA88D
C9	680 pF	Capacitor, Ceramic, 50V, \pm 5%, C0G, SMT 0402	Murata	GRM1555C1H681JA01D
C10	0.01 μ F	Capacitor, Ceramic, 16V, \pm 10%, X7R, SMT 0402	Murata	GRM155R71C103KA01D
C11	1.0 pF	Capacitor, Ceramic, 50V, \pm 0.1 pF, UHI-Q NP0, SMT 0402	Johanson Technology	500R07S1R0BV4
C12	0.9 pF	Capacitor, Ceramic, 50V, \pm 0.1 pF, UHI-Q NP0, SMT 0402	Johanson Technology	500R07S0R9BV4
FL1	TA0281A	Filter, SAW, 902–928 MHz	Tai-saw Technology	TA0281A
L1	10 nH	Inductor, Ceramic, \pm 5%, SMT 0402	Johanson Technology	L-07C10NJV6T
L2	100 nH	Inductor, Ceramic, \pm 5%, SMT 0402	Johanson Technology	L-07CR10JV6T
L3	5.6 nH	Inductor, Wirewound, \pm 5%, SMT 0402	Johanson Technology	L-07W5N6JV4T
L4	5.6 nH	Inductor, Wirewound, \pm 5%, SMT 0402	Johanson Technology	L-07W5N6JV4T
L5	—	Designator not used	—	—
L6	10 nH	Inductor, Ceramic, \pm 5%, SMT 0402	Johanson Technology	L-07C10NJV6T
R1	1 Ω	Resistor, 1%, \pm 100 ppm/ $^{\circ}$ C, SMT 0402	Vishay/Dale	CRCW04021R00FKED
R2	100K Ω	Resistor, 5%, \pm 100 ppm/ $^{\circ}$ C, SMT 0402	Yageo	RC0402JR-07100KL
R3	6.8K Ω	Resistor, 1%, \pm 100 ppm/ $^{\circ}$ C, SMT 0402	Yageo	RC0402FR-076K8L
U1	MRF89XA	Transceiver, Ultra Low-Power, Integrated Sub-GHz	Microchip Technology	MRF89XA-I/MQ
X1	12.8 MHz	Crystal, \pm 10 ppm, 15 pF, ESR 100 ohms, SMT 5 x 3.2mm	Abracon	ABM3B-155-12.800MHz-T

MRF89XAM9A

2.2 Printed Circuit Board

The MRF89XAM9A module PCB is constructed with high temperature FR4 material that is four layers and 0.032 inches thick. The layers are shown in Figure 2-3 through Figure 2-8. The PCB layer stack up is shown in Figure 2-9

FIGURE 2-3: TOP SILK SCREEN

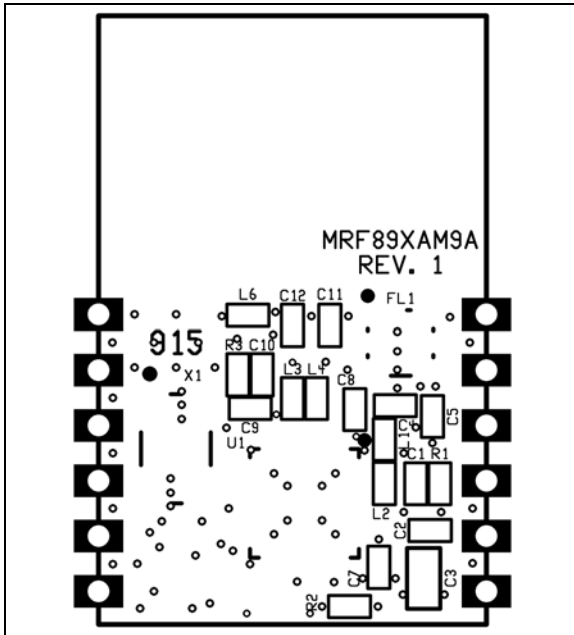

FIGURE 2-4: TOP COPPER

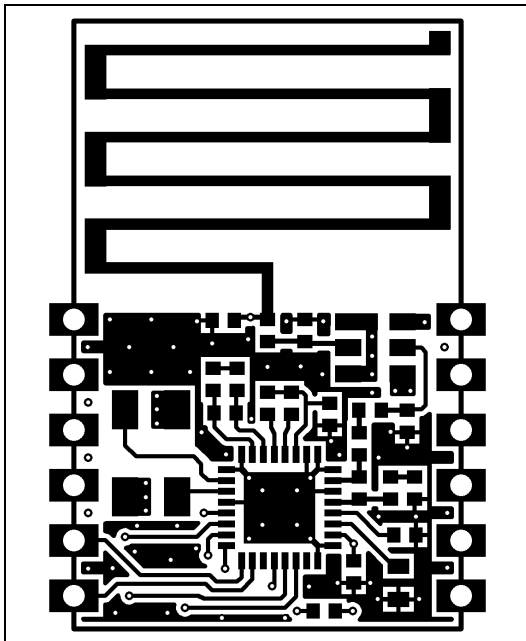

FIGURE 2-5: LAYER 2 — GROUND PLANE

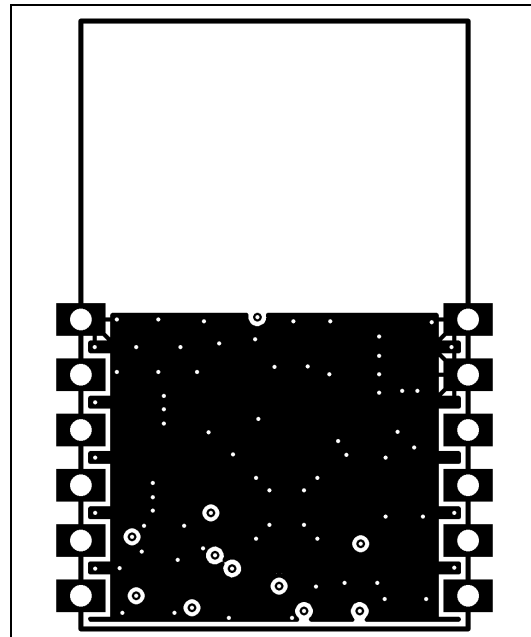

FIGURE 2-6: LAYER 3 — POWER PLANE

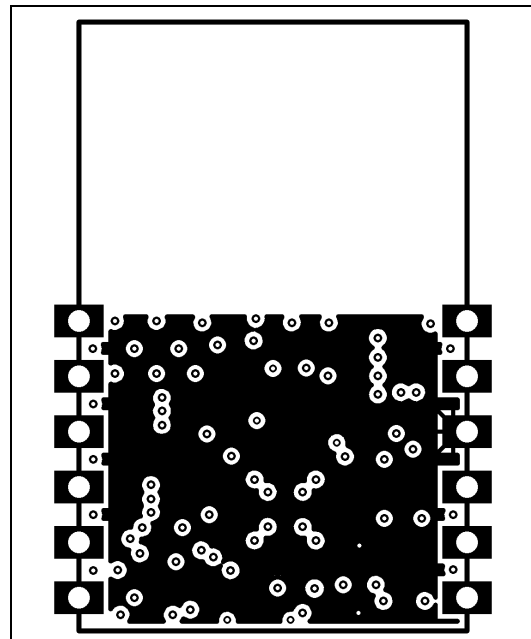

FIGURE 2-7: BOTTOM COPPER

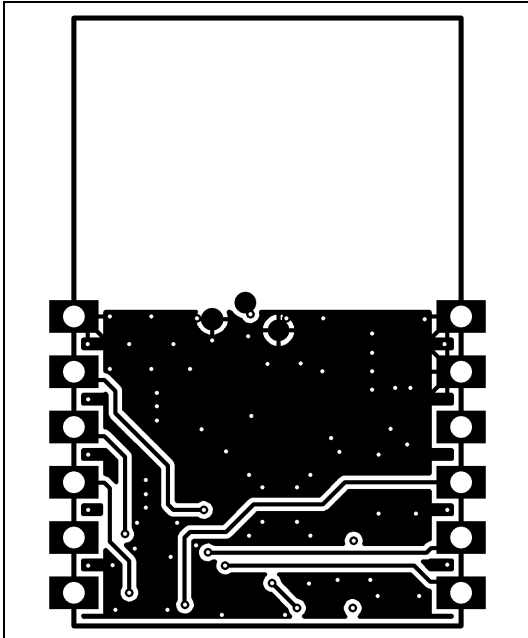

FIGURE 2-8: BOTTOM SILK SCREEN

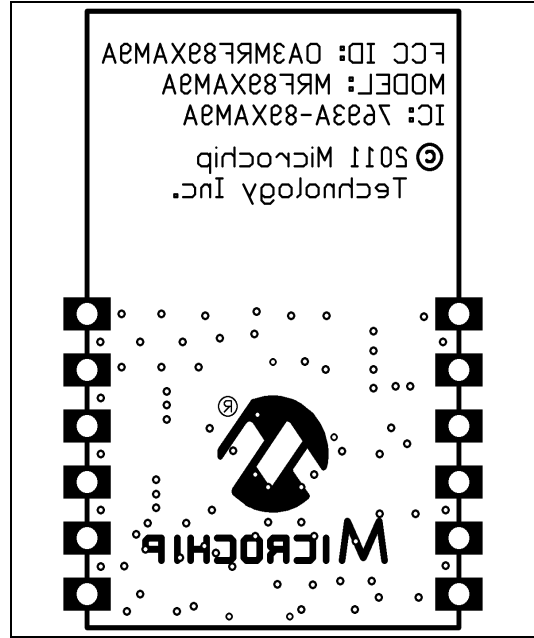
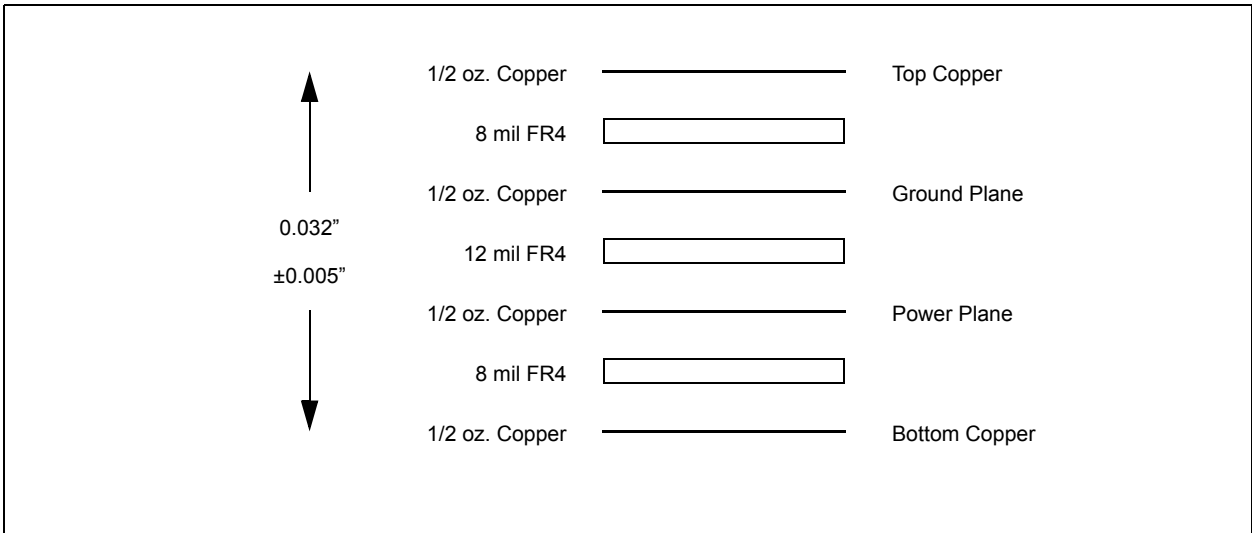

FIGURE 2-9: PCB LAYER STACK UP



MRF89XAM9A

2.3 PCB Antenna

The PCB antenna is fabricated on the top copper trace. [Figure 2-10](#) shows the PCB antenna dimensions. The layers below the antenna have no copper traces. The ground and power planes under the components serve as a counterpoise to the PCB antenna. Additional ground plane on the host PCB will substantially enhance the performance of the module. For best performance, place the module on the host PCB by following the recommendations in [Section 1.2, Mounting Details](#).

The PCB antenna was designed and simulated using Ansoft Designer[®] and HFSS[™] 3D full-wave solver software by ANSYS, Inc. (www.ansoft.com). The goal of the design was to create a compact, low-cost antenna with the best radiation pattern. [Figure 2-11](#) shows the PCB antenna simulation drawing and [Figure 2-12](#) and [Figure 2-13](#) show the simulated 2D and 3D radiation patterns. As shown by the radiation patterns, the performance of the antenna is dependant upon the orientation of the module. [Figure 2-14](#) shows the impedance simulation and [Figure 2-15](#) shows the actual impedance measurement. The discrete

matching circuitry matches the impedance of the antenna with the SAW filter and MRF89XA transceiver IC.

FIGURE 2-10: PCB ANTENNA DIMENSIONS

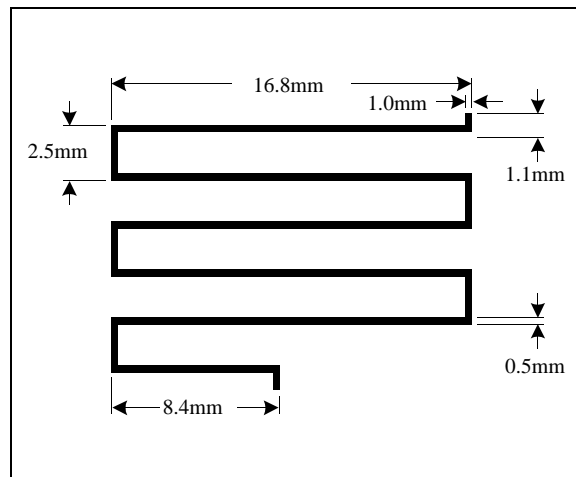

FIGURE 2-11: PCB ANTENNA SIMULATION DRAWING

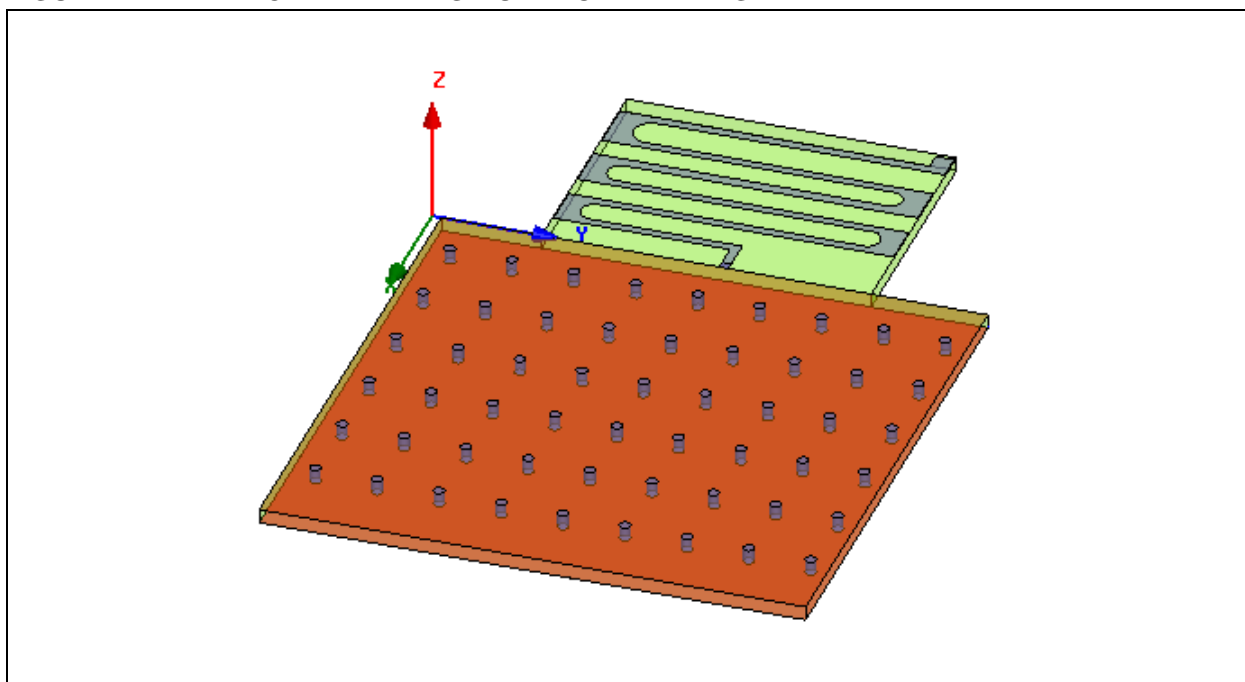

FIGURE 2-12: SIMULATED 2D RADIATION PATTERN

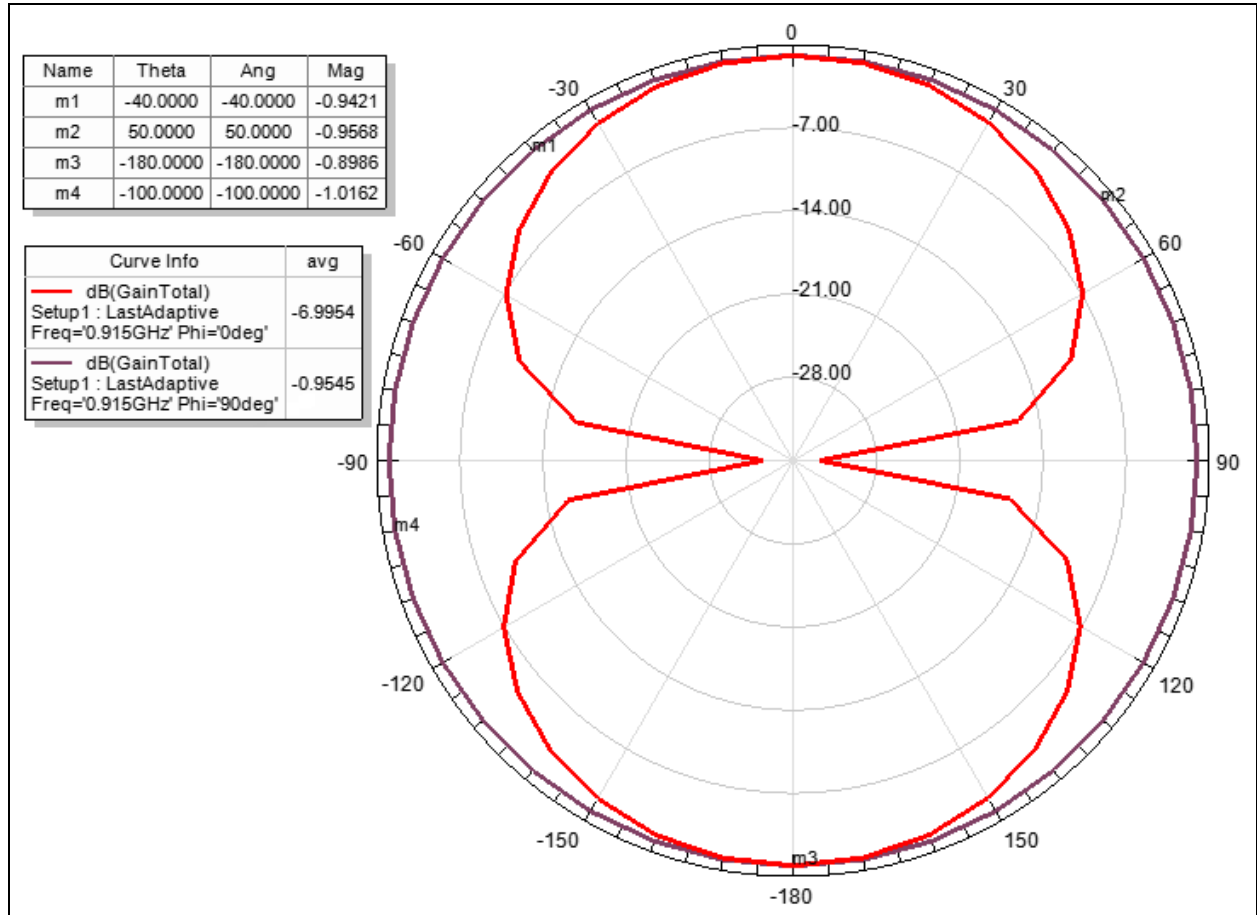
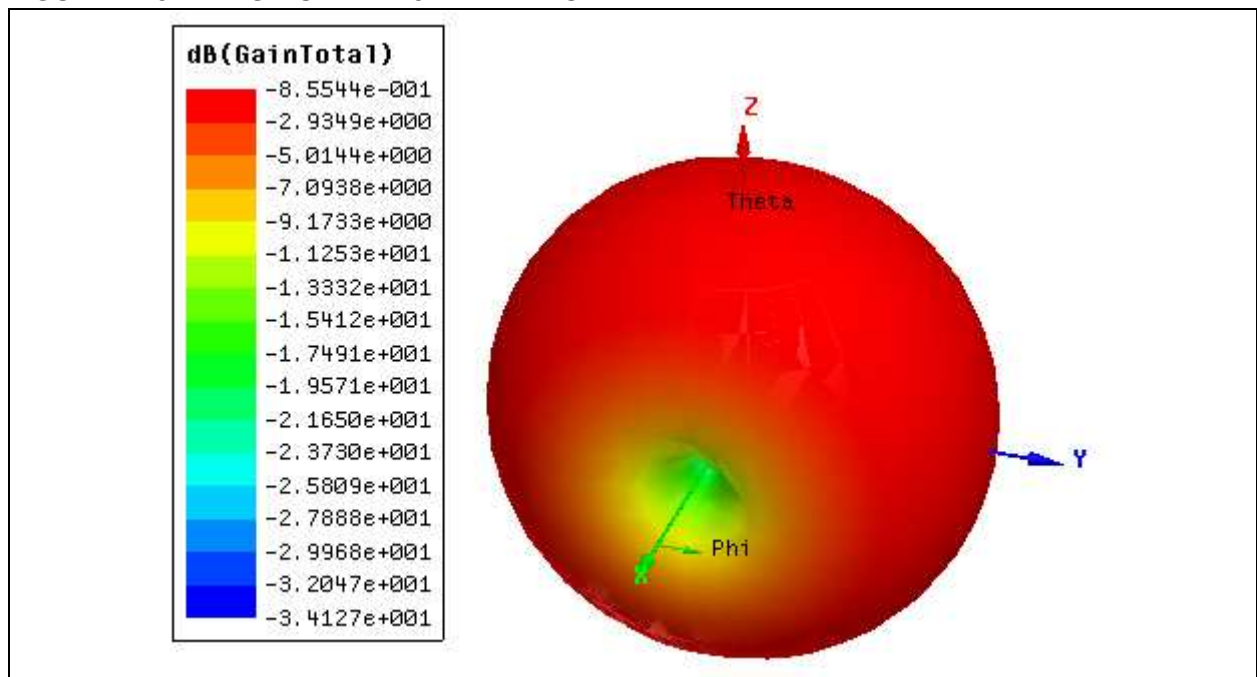

FIGURE 2-13: SIMULATED 3D RADIATION PATTERN



MRF89XAM9A

FIGURE 2-14: SIMULATED PCB ANTENNA IMPEDANCE

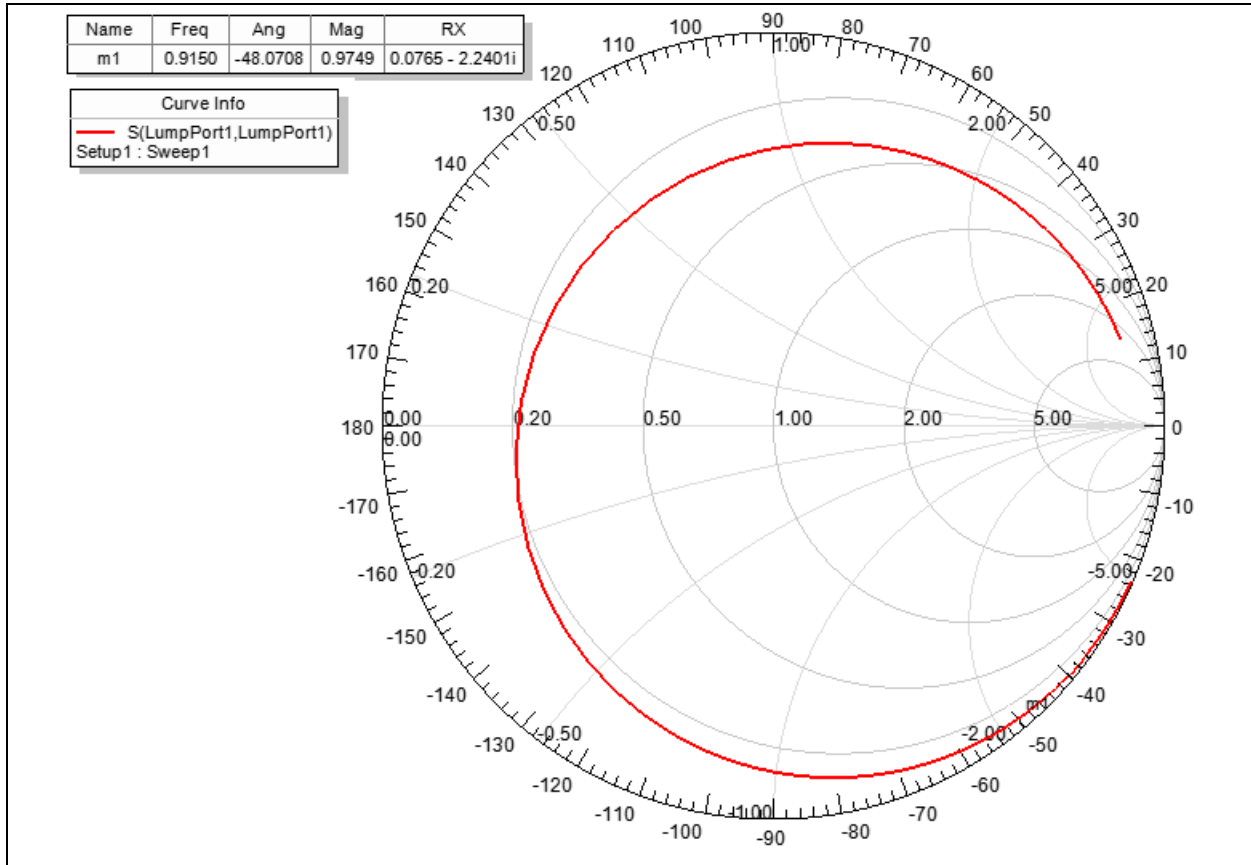
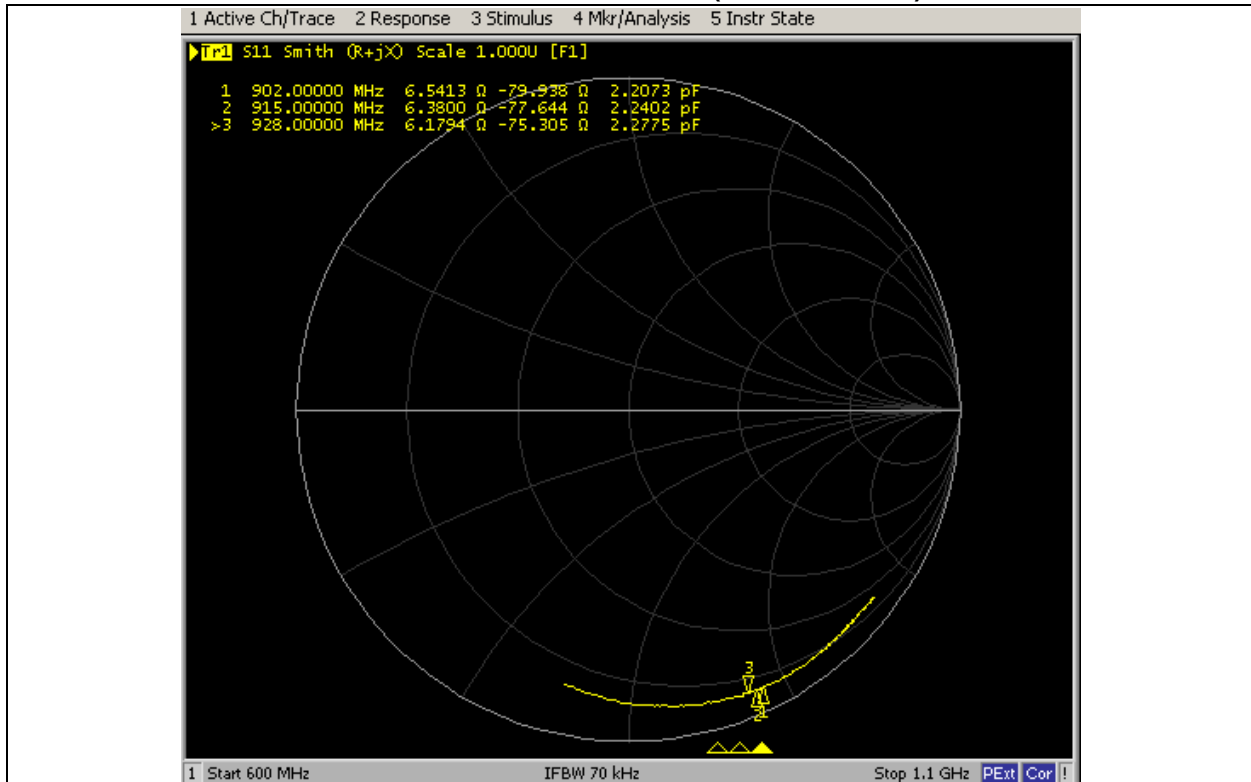

FIGURE 2-15: MEASURED ANTENNA IMPEDANCE (915 MHZ BAND)



3.0 REGULATORY APPROVAL

The MRF89XAM9A module has received regulatory approvals for modular devices in the United States and Canada. Modular device approval allows the end user to place the MRF89XAM9A module inside a finished product and not require regulatory testing for an intentional radiator (RF transmitter), provided no changes or modifications are made to the module circuitry. Changes or modifications could void the user's authority to operate the equipment. The end user must comply with all of the instructions provided by the Grantee, which indicate installation and/or operating conditions necessary for compliance.

The integrator is still responsible for testing the end product for any additional compliance requirements required with this module installed (digital device emission, PC peripheral requirements, etc.) in the specific country that the end device will be marketed.

For more information on regulatory compliance, refer to the specific country radio regulations in the following sections.

3.1 United States

The MRF89XAM9A has received Federal Communications Commission (FCC) CFR47 Telecommunications, Part 15 Subpart C "Intentional Radiators" 15.247 and 15.249 and modular approval in accordance with Part 15.212 Modular Transmitter approval. The MRF89XAM9A module can be integrated into a finished product without obtaining subsequent and separate FCC certification.

The MRF89XAM9A module has been labeled with its own FCC ID number, and if the FCC ID is not visible when the module is installed inside another device, then the outside of the finished product into which the module is installed must also display a label referring to the enclosed module. This exterior label can use wording as following:

Contains Transmitter Module FCC ID:
OA3MRF89XAM9A
-or-
Contains FCC ID: OA3MRF89XAM9A
This device complies with Part 15 of the FCC Rules. Operation is subject to the following two conditions:
(1) this device may not cause harmful interference, and (2) this device must accept any interference received, including interference that may cause undesired operation.

Requirements for product labeling are given in Part 15.19 Labeling Requirements.

The user's manual should include the following statement:

This equipment has been tested and found to comply with the limits for a Class B digital device, pursuant to part 15 of the FCC Rules. These limits are designed to provide reasonable protection against harmful interference in a residential installation. This equipment generates, uses and can radiate radio frequency energy, and if not installed and used in accordance with the instructions, may cause harmful interference to radio communications. However, there is no guarantee that interference will not occur in a particular installation. If this equipment does cause harmful interference to radio or television reception, which can be determined by turning the equipment OFF and ON, the user is encouraged to try to correct the interference by one or more of the following measures:

- Reorient or relocate the receiving antenna.
- Increase the separation between the equipment and receiver.
- Connect the equipment into an outlet on a circuit different from that to which the receiver is connected.
- Consult the dealer or an experienced radio/TV technician for help.

3.1.1 MRF89XAM9A SETTINGS

To meet the FCC requirements, the following settings must be observed by the integrator:

3.1.1.1 FSK Modulation

The following settings configure the MRF89XAM9A for wideband digital modulation techniques that conform to the requirements of Part 15.247. These settings allow higher radio frequency (RF) output power and greater link budget:

- Bit Rate Setting: 50 - 200 kbps
 - Transmit Power Maximum Setting: 13 dBm
- Bit Rate Setting: 2 - 40 kbps
 - Transmit Power Maximum Setting: 7 dBm
- Frequency Deviation Setting: 200 kHz
- Data Whitening: On
- Lower Frequency Setting: 902.800 MHz
- Upper Frequency Setting: 926.500 MHz

MRF89XAM9A

3.1.1.2 OOK Modulation

The following settings configure the MRF89XAM9A for narrowband operation that conform to the requirements of the part 15.249. The part 15.249 requires a much lower power setting than it is allowed in the part 15.247. These settings are good for applications that require lower transmit power current consumption and shorter transmit distances:

- Transmit Power Maximum Setting: 1 dBm
- Bit Rate Maximum Setting: 28 kbps
- Frequency Deviation Setting: 200 kHz
- Lower Frequency Setting: 902.330 MHz
- Upper Frequency Setting: 927.500 MHz

3.1.2 RF EXPOSURE

All transmitters regulated by FCC must comply with RF exposure requirements. OET Bulletin 65 "*Evaluating Compliance with FCC Guidelines for Human Exposure to Radio Frequency Electromagnetic Fields*" provides assistance in determining whether proposed or existing transmitting facilities, operations or devices comply with limits for human exposure to RF fields adopted by the Federal Communications Commission (FCC). The bulletin offers guidelines and suggestions for evaluating compliance.

If appropriate, compliance with exposure guidelines for mobile and unlicensed devices can be accomplished by using warning labels and by providing informations concerning minimum separation distances from transmitting structures and proper installation of antennas.

The following statement must be included as a CAUTION statement in manuals and OEM products to alert users of FCC RF Exposure compliance:

To satisfy FCC RF Exposure requirements for mobile and base station transmission devices, a separation distance of 20 cm or more should be maintained between the antenna of this device and persons during operation. To ensure compliance, operation at closer than this distance is not recommended.

The antenna(s) used for this transmitter must not be co-located or operating in conjunction with any other antenna or transmitter.

If the MRF89XAM9A module is used in a portable application (antenna is less than 20 cm from persons during operation), the integrator is responsible for performing Specific Absorption Rate (SAR) testing in accordance with FCC rules 2.1091.

3.1.3 HELPFUL WEB SITES

Federal Communications Commission (FCC) <http://www.fcc.gov>

3.2 Canada

The MRF89XAM9A module has been certified for use in Canada under Industry Canada (IC) Radio Standards Specification (RSS) RSS-210 and RSS-Gen. Modular approval permits the installation of a module in a host device without the need to recertify the device.

Labeling Requirements for the Host Device (from Section 3.2.1, RSS-Gen, Issue 3, December 2010):

The host device must be labeled to identify the module within the host device.

The Industry Canada certification label of a module shall be clearly visible at all times when installed in the host device, otherwise the host device must be labeled to display the Industry Canada certification number of the module, preceded by the words "Contains transmitter module", or the word "Contains", or similar wording expressing the same meaning, as follows:

Contains transmitter module IC: 7693A-89XAM9A

User Manual Notice for License-Exempt Radio Apparatus (from Section 7.1.3 RSS-Gen, Issue 3, December 2010):

User manuals for license-exempt radio apparatus must contain the following or equivalent notice in a conspicuous location in the user manual or alternatively on the device or both.

This device complies with Industry Canada license-exempt RSS standard(s). Operation is subject to the following two conditions: (1) this device may not cause interference, and (2) this device must accept any interference, including interference that may cause undesired operation of the device.

Le présent appareil est conforme aux CNR d'Industrie Canada applicables aux appareils radio exempts de licence. L'exploitation est autorisée aux deux conditions suivantes: (1) l'appareil ne doit pas produire de brouillage, et (2) l'utilisateur de l'appareil doit accepter tout brouillage radioélectrique subi, même si le brouillage est susceptible d'en compromettre le fonctionnement.

3.2.1 MRF89XAM9A SETTINGS

To meet Industry Canada (IC) requirements, the following settings must be observed by the integrator:

3.2.1.1 FSK Modulation

The following settings configure the MRF89XAM9A for wideband digital modulation techniques that conform to the requirements of RSS-210 Issue 8, Annex 8. These settings allow higher radio frequency (RF) output power and greater link budget.

- Bit Rate Setting: 50–200 kbps
 - Transmit Power Maximum Setting: 13 dBm
- Bit Rate Setting: 2–40 kbps
 - Transmit Power Maximum Setting: 7 dBm
- Frequency Deviation Setting: 200 kHz
- Data Whitening: On
- Lower Frequency Setting: 902.800 MHz
- Upper Frequency Setting: 926.500 MHz

3.2.1.2 OOK Modulation

The following settings configure the MRF89XAM9A for narrowband operation that conform to the requirements of RSS-Gen Issue 3. RSS-Gen Issue 3 requires a much lower power setting than is allowed in Part RSS-210 Issue 8 Annex 8. These settings are good for applications that require lower transmit power current consumption and shorter transmit distances.

- Transmit Power Maximum Setting: 1 dBm
- Bit Rate Maximum Setting: 28 kbps
- Frequency Deviation Setting: 200 kHz
- Lower Frequency Setting: 902.330 MHz
- Upper Frequency Setting: 927.500 MHz

3.2.2 HELPFUL WEB SITES

Industry Canada: <http://www.ic.gc.ca/>

MRF89XAM9A

NOTES:

4.0 ELECTRICAL CHARACTERISTICS

Absolute Maximum Ratings

Ambient temperature under bias	-40°C to +85°C
Storage temperature	-55°C to +125°C
Voltage on VIN with respect to VSS	-0.3V to 6V
Voltage on any combined digital and analog pin with respect to VSS (except VIN)	-0.3V to (VIN + 0.3V)
Input current into pin (except VIN and VSS).....	-25 mA to 25 mA

NOTICE: Stresses above those listed under “Absolute Maximum Ratings” may cause permanent damage to the device. This is a stress rating only and functional operation of the device at those or any other conditions above those indicated in the operation listings of this specification is not implied. Exposure to maximum rating conditions for extended periods may affect device reliability.

MRF89XAM9A

TABLE 4-1: RECOMMENDED OPERATING CONDITIONS

Parameter	Min	Typ	Max	Unit	Condition
Ambient Operating Temperature	-40	—	+85	°C	—
Supply Voltage for RF, Analog and Digital Circuits	2.1	—	3.6	V	—
Supply Voltage for Digital I/O	2.1	—	3.6	V	—
Input High Voltage (V _{IH})	0.5 * V _{IN}	—	V _{IN} + 0.3	V	—
Input Low Voltage (V _{IL})	-0.3V	—	0.2 * V _{IN}	V	—
AC Peak Voltage on Open Collector Outputs (I _O) ⁽¹⁾	V _{IN} - 1.5	—	V _{IN} + 1.5	V	—

Note 1: At minimum, V_{IN} - 1.5V should not be lower than 1.8V.

TABLE 4-2: CURRENT CONSUMPTION

Symbol	Chip Mode	Min	Typ	Max	Unit	Condition
IDDSL	Sleep	—	0.1	2	µA	Sleep clock disabled, all blocks disabled
IDDST	Idle	—	65	80	µA	Oscillator and baseband enabled
IDDFS	Frequency Synthesizer	—	1.3	1.7	mA	Frequency synthesizer running
IDDTX	Tx	—	25 16	30 21	mA mA	Output power = +10 dBm Output power = +1 dBm ⁽¹⁾
IDDRX	Rx	—	3.0	3.5	mA	—

Note 1: Guaranteed by design and characterization.

TABLE 4-3: DIGITAL I/O PIN INPUT SPECIFICATIONS⁽¹⁾

Symbol	Characteristic	Min	Typ	Max	Unit	Condition
V _{IL}	Input Low Voltage	—	—	0.2 * V _{IN}	V	—
V _{IH}	Input High Voltage	0.8 * V _{IN}	—	—	V	—
I _{IL}	Input Low Leakage Current ⁽²⁾	-0.5	—	0.5	µA	V _{IL} = 0V
I _{IH}	Input High Leakage Current	-0.5	—	0.5	µA	V _{IH} = V _{IN} , V _{IN} = 3.7
V _{OL}	Digital Low Output Voltage	—	—	0.1 * V _{IN}	—	I _{OL} = 1 mA
V _{OH}	Digital Low Output	0.9 * V _{IN}	—	—	V	I _{OH} = -1 mA

Note 1: Measurement Conditions: T_A = 25°C, V_{IN} = 3.3V, Crystal Frequency = 12.8 MHz, unless otherwise specified.

2: Negative current is defined as the current sourced by the pin.

TABLE 4-4: PLL PARAMETERS AC CHARACTERISTICS⁽¹⁾

Symbol	Parameter	Min	Typ	Max	Unit	Condition
FRO	Frequency Ranges	902	—	928	MHz	—
BRFSK	Bit Rate (FSK)	2	—	200	kbps	NRZ
BROOK	Bit Rate (OOK)	1.56	—	28	kbps	NRZ
FDFSK	Frequency Deviation (FSK)	33	—	200	kHz	—
FXTAL	Crystal Oscillator Frequency	—	12.8	—	MHz	—
FSSTP	Frequency Synthesizer Step	—	2	—	kHz	Variable, depending on the frequency
TSOSC	Oscillator Wake-up Time	—	1.5	5	ms	From Sleep mode ⁽¹⁾
TSFS	Frequency Synthesizer Wake-up Time; at most, 10 kHz away from the target	—	500	800	μs	From Stand-by mode
TSHOP	Frequency Synthesizer Hop Time; at most, 10 kHz away from the target	—	180	—	μs	200 kHz step
		—	200	—	μs	1 MHz step
		—	250	—	μs	5 MHz step
		—	260	—	μs	7 MHz step
		—	290	—	μs	12 MHz step
		—	320	—	μs	20 MHz step
		—	340	—	μs	27 MHz step

Note 1: Guaranteed by design and characterization.

MRF89XAM9A

TABLE 4-5: RECEIVER AC CHARACTERISTICS⁽¹⁾

Symbol	Parameter	Min	Typ	Max	Unit	Condition
RSF	Sensitivity (FSK)	—	-105	—	dBm	915 MHz, BR = 25 kbps, $f_{dev} = 50$ kHz, $f_c = 100$ kHz
		—	-101	—	dBm	915 MHz, BR = 66.7 kbps, $f_{dev} = 100$ kHz, $f_c = 200$ kHz
RSO	Sensitivity (OOK)	—	-111	—	dBm	915 MHz, 2 kbps NRZ $f_c - f_o = 50$ kHz, $f_o = 50$ kHz
		—	-105	—	dBm	915 MHz, 16.7 kbps NRZ $f_c - f_o = 100$ kHz, $f_o = 100$ kHz
CCR	Co-Channel Rejection	—	-12	—	dBc	Modulation as wanted signal
ACR	Adjacent Channel Rejection	—	27	—	dB	Offset = 300 kHz, unwanted tone is not modulated
		—	52	—	dB	Offset = 600 kHz, unwanted tone is not modulated
		—	57	—	dB	Offset = 1.2 MHz, unwanted tone is not modulated
BI	Blocking Immunity	—	-48	—	dBm	Offset = 1 MHz, unmodulated
		—	-37	—	dBm	Offset = 2 MHz, unmodulated, no SAW
		—	-33	—	dBm	Offset = 10 MHz, unmodulated, no SAW
RXBWF	Receiver Bandwidth in FSK Mode ⁽²⁾	50	—	250	kHz	Single side BW, Polyphase Off
RXBWU	Receiver Bandwidth in OOK Mode ⁽²⁾	50	—	400	kHz	Single side BW, Polyphase On
ITP3	Input Third Order Intercept Point	—	-28	—	dBm	Interferers at 1 MHz and 1.950 MHz offset
TSRWF	Receiver Wake-up Time	—	280	500	μs	From FS to Rx ready
TSRWS	Receiver Wake-up Time	—	600	900	μs	From Stand-by to Rx ready
TSRHOP	Receiver Hop Time from Rx Ready to Rx Ready with a Frequency Hop	—	400	—	μs	200 kHz step
		—	400	—	μs	1 MHz step
		—	460	—	μs	5 MHz step
		—	480	—	μs	7 MHz step
		—	520	—	μs	12 MHz step
		—	550	—	μs	20 MHz step
		—	600	—	μs	27 MHz step
RSSIST	RSSI Sampling Time	—	—	$1/f_{dev}$	s	From Rx ready
RSSTDR	RSSI Dynamic Range	—	70	—	dB	Ranging from sensitivity

Note 1: Guaranteed by design and characterization.

2: This reflects the whole receiver bandwidth, as described by conditions for active and passive filters.

TABLE 4-6: TRANSMITTER AC CHARACTERISTICS⁽¹⁾

Symbol	Description	Min	Typ	Max	Unit	Condition
RFOP	RF Output Power, Programmable with 8 Steps of typ. 3 dB	—	+12.5	—	dBm	Maximum power setting
		—	-8.5	—	dBm	Minimum power setting
PN	Phase Noise	—	-112	—	dBc/Hz	Measured with a 600 kHz offset at the transmitter output
TXSP	Transmitted Spurious	—	—	-47	dBc	At any offset between 200 kHz and 600 kHz, unmodulated carrier, $f_{dev} = 50$ kHz
Tx2	Second Harmonic	—	—	-40	dBm	No modulation, see Note ⁽²⁾
Tx3	Third Harmonic					
Tx4	Fourth Harmonic					
Txn	Harmonics above Tx4					
FSKDEV	FSK Deviation	±33	±55	±200	kHz	Programmable
TSTWF	Transmitter Wake-up Time	—	120	500	µs	From FS to Tx ready
TSTWS	Transmitter Wake-up Time	—	600	900	µs	From Stand-by to Tx ready

Note 1: Guaranteed by design and characterization.

2: Transmitter in-circuit performance with SAW filter and crystal.

4.1 Timing Specification and Diagram

TABLE 4-7: SPI TIMING SPECIFICATION^(1,2)

Parameter	Min	Typ	Max	Unit	Condition
SPI Configure Clock Frequency	—	—	6	MHz	—
SPI Data Clock Frequency	—	—	1	MHz	—
Data Hold and Setup Time	2	—	—	µs	—
SDI Setup Time for SPI Configure	250	—	—	ns	—
SDI Setup Time for SPI Data	312	—	—	ns	—
$\overline{\text{CSCON}}$ Low to SCK Rising Edge; SCK Falling Edge to $\overline{\text{CSCON}}$ High	500	—	—	ns	—
$\overline{\text{CSDATA}}$ Low to SCK Rising Edge; SCK Falling Edge to $\overline{\text{CSDATA}}$ High	625	—	—	ns	—
$\overline{\text{CSCON}}$ Rising to Falling Edge	500	—	—	ns	—
$\overline{\text{CSDATA}}$ Rising to Falling Edge	625	—	—	ns	—

Note 1: Typical Values: $T_A = 25^\circ\text{C}$, $V_{IN} = 3.3\text{V}$, Crystal Frequency = 12.8 MHz, unless otherwise specified.

2: Negative current is defined as the current sourced by the pin.

MRF89XAM9A

NOTES:

APPENDIX A: REVISION HISTORY

Revision A (July 2011)

This is the Initial release of the document.

MRF89XAM9A

NOTES:

THE MICROCHIP WEB SITE

Microchip provides online support via our WWW site at www.microchip.com. This web site is used as a means to make files and information easily available to customers. Accessible by using your favorite Internet browser, the web site contains the following information:

- **Product Support** – Data sheets and errata, application notes and sample programs, design resources, user's guides and hardware support documents, latest software releases and archived software
- **General Technical Support** – Frequently Asked Questions (FAQ), technical support requests, online discussion groups, Microchip consultant program member listing
- **Business of Microchip** – Product selector and ordering guides, latest Microchip press releases, listing of seminars and events, listings of Microchip sales offices, distributors and factory representatives

CUSTOMER CHANGE NOTIFICATION SERVICE

Microchip's customer notification service helps keep customers current on Microchip products. Subscribers will receive e-mail notification whenever there are changes, updates, revisions or errata related to a specified product family or development tool of interest.

To register, access the Microchip web site at www.microchip.com. Under "Support", click on "Customer Change Notification" and follow the registration instructions.

CUSTOMER SUPPORT

Users of Microchip products can receive assistance through several channels:

- Distributor or Representative
- Local Sales Office
- Field Application Engineer (FAE)
- Technical Support
- Development Systems Information Line

Customers should contact their distributor, representative or field application engineer (FAE) for support. Local sales offices are also available to help customers. A listing of sales offices and locations is included in the back of this document.

Technical support is available through the web site at: <http://microchip.com/support>

MRF89XAM9A

READER RESPONSE

It is our intention to provide you with the best documentation possible to ensure successful use of your Microchip product. If you wish to provide your comments on organization, clarity, subject matter, and ways in which our documentation can better serve you, please FAX your comments to the Technical Publications Manager at (480) 792-4150.

Please list the following information, and use this outline to provide us with your comments about this document.

TO: Technical Publications Manager Total Pages Sent _____

RE: Reader Response

From: Name _____

Company _____

Address _____

City / State / ZIP / Country _____

Telephone: (_____) _____ - _____ FAX: (_____) _____ - _____

Application (optional):

Would you like a reply? Y N

Device: MRF89XAM9A

Literature Number: DS75017A

Questions:

1. What are the best features of this document?

2. How does this document meet your hardware and software development needs?

3. Do you find the organization of this document easy to follow? If not, why?

4. What additions to the document do you think would enhance the structure and subject?

5. What deletions from the document could be made without affecting the overall usefulness?

6. Is there any incorrect or misleading information (what and where)?

7. How would you improve this document?



MICROCHIP

Worldwide Sales and Service

AMERICAS

Corporate Office
2355 West Chandler Blvd.
Chandler, AZ 85224-6199
Tel: 480-792-7200
Fax: 480-792-7277
Technical Support:
<http://www.microchip.com/support>
Web Address:
www.microchip.com

Atlanta
Duluth, GA
Tel: 678-957-9614
Fax: 678-957-1455

Boston
Westborough, MA
Tel: 774-760-0087
Fax: 774-760-0088

Chicago
Itasca, IL
Tel: 630-285-0071
Fax: 630-285-0075

Cleveland
Independence, OH
Tel: 216-447-0464
Fax: 216-447-0643

Dallas
Addison, TX
Tel: 972-818-7423
Fax: 972-818-2924

Detroit
Farmington Hills, MI
Tel: 248-538-2250
Fax: 248-538-2260

Indianapolis
Noblesville, IN
Tel: 317-773-8323
Fax: 317-773-5453

Los Angeles
Mission Viejo, CA
Tel: 949-462-9523
Fax: 949-462-9608

Santa Clara
Santa Clara, CA
Tel: 408-961-6444
Fax: 408-961-6445

Toronto
Mississauga, Ontario,
Canada
Tel: 905-673-0699
Fax: 905-673-6509

ASIA/PACIFIC

Asia Pacific Office
Suites 3707-14, 37th Floor
Tower 6, The Gateway
Harbour City, Kowloon
Hong Kong
Tel: 852-2401-1200
Fax: 852-2401-3431

Australia - Sydney
Tel: 61-2-9868-6733
Fax: 61-2-9868-6755

China - Beijing
Tel: 86-10-8569-7000
Fax: 86-10-8528-2104

China - Chengdu
Tel: 86-28-8665-5511
Fax: 86-28-8665-7889

China - Chongqing
Tel: 86-23-8980-9588
Fax: 86-23-8980-9500

China - Hangzhou
Tel: 86-571-2819-3180
Fax: 86-571-2819-3189

China - Hong Kong SAR
Tel: 852-2401-1200
Fax: 852-2401-3431

China - Nanjing
Tel: 86-25-8473-2460
Fax: 86-25-8473-2470

China - Qingdao
Tel: 86-532-8502-7355
Fax: 86-532-8502-7205

China - Shanghai
Tel: 86-21-5407-5533
Fax: 86-21-5407-5066

China - Shenyang
Tel: 86-24-2334-2829
Fax: 86-24-2334-2393

China - Shenzhen
Tel: 86-755-8203-2660
Fax: 86-755-8203-1760

China - Wuhan
Tel: 86-27-5980-5300
Fax: 86-27-5980-5118

China - Xian
Tel: 86-29-8833-7252
Fax: 86-29-8833-7256

China - Xiamen
Tel: 86-592-2388138
Fax: 86-592-2388130

China - Zhuhai
Tel: 86-756-3210040
Fax: 86-756-3210049

ASIA/PACIFIC

India - Bangalore
Tel: 91-80-3090-4444
Fax: 91-80-3090-4123

India - New Delhi
Tel: 91-11-4160-8631
Fax: 91-11-4160-8632

India - Pune
Tel: 91-20-2566-1512
Fax: 91-20-2566-1513

Japan - Yokohama
Tel: 81-45-471- 6166
Fax: 81-45-471-6122

Korea - Daegu
Tel: 82-53-744-4301
Fax: 82-53-744-4302

Korea - Seoul
Tel: 82-2-554-7200
Fax: 82-2-558-5932 or
82-2-558-5934

Malaysia - Kuala Lumpur
Tel: 60-3-6201-9857
Fax: 60-3-6201-9859

Malaysia - Penang
Tel: 60-4-227-8870
Fax: 60-4-227-4068

Philippines - Manila
Tel: 63-2-634-9065
Fax: 63-2-634-9069

Singapore
Tel: 65-6334-8870
Fax: 65-6334-8850

Taiwan - Hsin Chu
Tel: 886-3-6578-300
Fax: 886-3-6578-370

Taiwan - Kaohsiung
Tel: 886-7-213-7830
Fax: 886-7-330-9305

Taiwan - Taipei
Tel: 886-2-2500-6610
Fax: 886-2-2508-0102

Thailand - Bangkok
Tel: 66-2-694-1351
Fax: 66-2-694-1350

EUROPE

Austria - Wels
Tel: 43-7242-2244-39
Fax: 43-7242-2244-393

Denmark - Copenhagen
Tel: 45-4450-2828
Fax: 45-4485-2829

France - Paris
Tel: 33-1-69-53-63-20
Fax: 33-1-69-30-90-79

Germany - Munich
Tel: 49-89-627-144-0
Fax: 49-89-627-144-44

Italy - Milan
Tel: 39-0331-742611
Fax: 39-0331-466781

Netherlands - Druenen
Tel: 31-416-690399
Fax: 31-416-690340

Spain - Madrid
Tel: 34-91-708-08-90
Fax: 34-91-708-08-91

UK - Wokingham
Tel: 44-118-921-5869
Fax: 44-118-921-5820

05/02/11