



PMT 211A-RO

High impedance passive probe

Features:

- CeramCore™ Hybrid Probe
- Modular Construction
- Coaxial Design
- Interchangeable Spring Contact Tip
- IC Contacting System 0.8 to 1.27 mm pitch



The PMT 211A-RO is a 250 MHz, standard sized, 10:1 passive probe designed for instruments having 1 M Ω input resistance. This probe is recommended for general purpose probing applications and is adjustable for low and high frequencies. The probe is rated with 300 V CAT II maximum input voltage and complies with latest safety standards. Like every PMK passive probe the PMT 211A features CeramCore™ technology. The probe's entire core is made of a high quality ceramic hybrid. Pure coaxial design and laser trimmed resistors ensure highest signal fidelity along the signal path offering high bandwidth and fast risetimes for accurate impulse measurements. All passive probes are equipped with PMK's signature spring loaded, needle sharp tips to support precise and safe measurements minimizing the risk of slipping off the board and produce a short circuit. Various types of tips are available. Besides the spring contact tips there is also a solid tip available at the users choice. Probe tips are interchangeable and can be replaced easily. Basic probe accessories and replacement tips are provided within the scope of delivery or can be purchased separately. The probes mechanical construction is modular and therefore spare probe leads are available. See this datasheet and corresponding documents for further details.

This datasheet supersedes all previously published material. Specifications that are not marked as guaranteed are published as general information to the user. The instrument should have warmed up for at least 20 minutes and the environmental conditions must not exceed the specified limits of the probe. Note that specifications are subject to change without notice.

Electrical Specifications

<i>Attenuation Ratio</i> ⁽¹⁾	10:1	± 2 % at DC
<i>Voltage Coefficient</i>	0.00025 % / V	
<i>Probe Bandwidth</i>	250 MHz	(-3 dB)
<i>Probe Risetime</i>	1.4 ns	(10 % – 90 %)
 <i>Maximum Rated Input Voltage</i> ⁽²⁾ ⁽³⁾		
<i>Measurement Category I:</i>	400 V rms, 1250 V transient overvoltage	
<i>Measurement Category II:</i>	300 V rms, CAT II	
<i>Pollution Degree</i> ⁽³⁾	2	

Voltage Derating

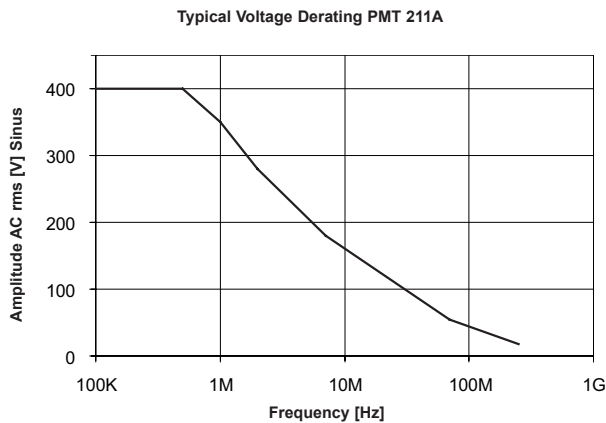

Make sure to comply with the max. Input Voltages stated here to avoid errors of linearity and damage to the probe.

(1) connected to oscilloscope with an input impedance of 1 MΩ ± 1 %
 (2) at 15 pF input capacitance of the measuring instrument
 (3) as defined in the CEI/IEC 61010-031:2002

Electrical Characteristics

<i>Input Resistance (system)</i>	10 MΩ	± 1 %
<i>Input Capacitance (system)</i>	12.5 pF	
<i>Compensation Range</i>	10 pF – 35 pF	
<i>Input Coupling of the Measuring Instrument</i>	1 MΩ AC / DC	

Input Impedance

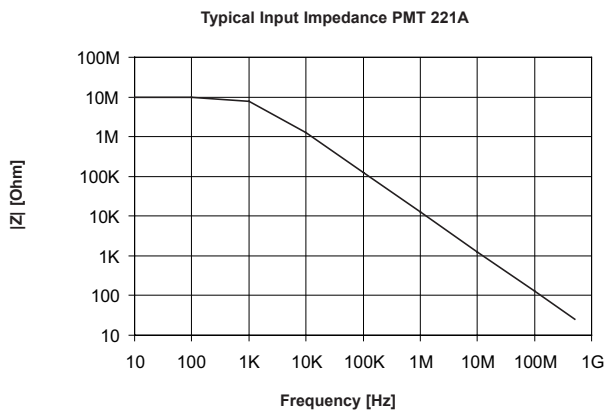

Note that the Input Impedance of the Probe decreases as the Frequency of the Applied Signal increases.

Mechanical Characteristics

Weight (probe only)	55 g
Cable Length	1.2 m
Probe Tip Diameter	5 mm

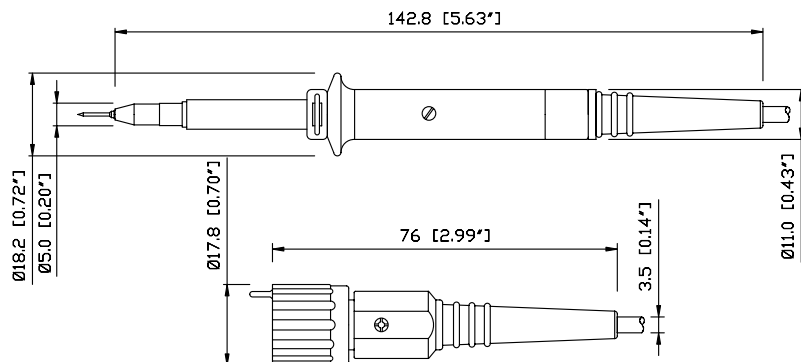



Environmental Specifications

<i>Altitude</i>	operating	up to 2000 m
	non-operating	up to 15000 m
<i>Temperature Range</i>	operating	0 °C to +50 °C
	non-operating	-40 °C to +71 °C
<i>Maximum Relative Humidity</i>	operating	80 % relative humidity for temperatures up to +31 °C, decreasing linearly to 40 % at +50 °C

Declaration of Conformity

The manufacturer declares the conformity of his products with the actual required safety standards in accordance with the Low Voltage Directive (LVD) 2006/95/EC:

CE/IEC 61010-031:2008

Safety requirements for electrical equipment for measurement, control and laboratory use.

Part 031:

Safety requirements for hand-held probe assemblies for electrical measurement and test.

WEEE/ RoHS Directives

PMK electronic products are classified within the WEEE/ RoHS* category list as monitoring and control equipment (category 9). Category 9 products are exempt from the restrictions under the scope of the RoHS directive.

Your help and efforts are required to protect and keep clean our environment. Therefore return any electronic product at the end of its life either to Service Department of PMK Mess- und Kommunikationstechnik GmbH or take care of separate WEEE collection and professional WEEE treatment yourself. Do not dispose as unsorted municipal waste.

* EC Directives:

- WEEE Directive 2002/96/EC – Waste Electrical and Electronic Equipment
- RoHS Directive 2002/95/EC – Restriction of the use of certain Hazardous Substances in Electrical and Electronic Equipment



Scope of Delivery PMT 211A Order No. 825-211-A00

- 2 Footer Positioner
- Adjustment Tool T
- BNC Adapter 5.0
- Ground Blade 5.0
- Ground Lead 22 cm
- IC-Caps 0.8 to 1.27 mm pitch
- Instruction Manual
- Insulating Cap 5.0
- Probe
- Protection Cap 5.0
- Solid Tip 0.8 mm
- Spring Tip 0.8 mm
- Sprung Hook 5.0

Safety Information

To avoid personal injury and to prevent fire or damage to this product or products connected to it, review and comply with the safety informations stated in the manual before using this product. Be aware that if you use this probe assembly in a manner not specified the protection this product provides may be impaired.

Only qualified personnel should use this probe assembly.

Manufacturer

PMK Mess- und Kommunikationstechnik GmbH
Königsteiner Str. 98
65812 Bad Soden, Germany

Internet: www.pmk.de

Tel: +49 (0) 6196 5927 - 930

E-Mail: sales@pmk.de

Fax: +49 (0) 6196 5927 - 939