



PML 751-RO

High impedance passive probe

Features:

- 2.5 mm Diameter Tip
- CeramCore™ Hybrid Probe
- Useable with any 50 Ω Instrument
- Interchangeable Spring Contact Tip
- IC Contacting System 0.5 to 1.27 mm pitch



PMK introduces a new universal 10:1 miniature probe for oscilloscopes with up to 1.5 GHz bandwidth. As all PMK probes the PML 751-RO features CeramCore™ technology. The entire probe core is made of a high quality ceramic hybrid. The probe is available with coaxial SMA, N and read-out BNC connector to be automatically recognised as 10:1 divider by scopes that feature a sense ring to detect probe attenuation such as Agilent, LeCroy or Tektronix.

Low Z-Miniature dividers are a low-cost alternative to active probes for high frequency measurements. They're built for use with instruments having 50 Ω inputs. Due to their low input impedance in the range up to 100 MHz the signal source must be able to accept some loading without difficulties. The compact design of this new probe with its 2.5 mm housing diameter at the tip provides better visibility to the DUT (device under test) in dense SMT circuits than conventional 5 mm housings. Due to the remarkably low input capacitance the signal source is only loaded by 1.8 pF. Less load to the measurement circuit can only be achieved with active probes. Especially when measuring signals with fast rise times often the probe's adaption to the source signal plays an important role. Long ground leads found on most conventional adaptions bring additional inductance and resonances into the setup which will result in false or inaccurate readings. The new IC contacting system consisting of five different IC adapters ranging from 1.27 to 0.5 mm pitch and the PCB adapter kit offer an ideal solution for short circuit-proof, reproducible measurements. As you would expect the probe is shipped with PMK's signature spring-loaded tips. In total there are 16 different accessories included in the scope of delivery with the new PML 751-RO offering adaptive solutions for a variety of probing demands.

This datasheet supersedes all previously published material. Specifications that are not marked as guaranteed are published as general information to the user. The instrument should have warmed up for at least 20 minutes and the environmental conditions must not exceed the specified limits of the probe. Note that specifications are subject to change without notice.

Electrical Specifications

<i>Attenuation Ratio</i> ⁽¹⁾	10:1	± 2 % at DC
<i>System Bandwidth</i>	1.5 GHz	(-3 dB)
<i>System Risetime</i>	240 ps	(10% – 90 %)
<i>Maximum Rated Input Voltage</i>	12 V DC incl. AC peak	

Voltage Derating

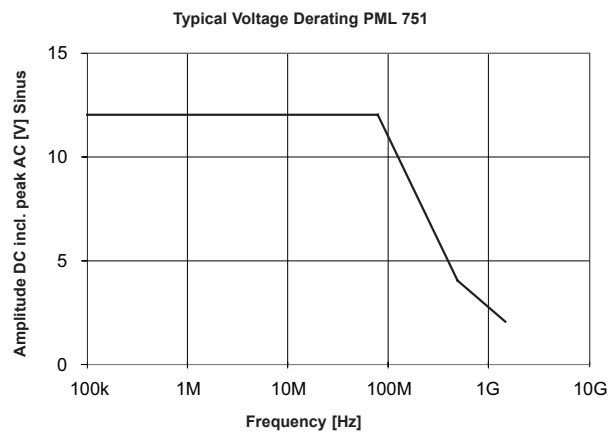

Note that the max. input voltage rating of the probe decreases as the frequency of the applied signal increases.

(1) Connected to oscilloscope with an input impedance of 50 Ω ± 1 %.

Electrical Characteristics

<i>Input Resistance (system)</i>	500 Ω	± 1 %
<i>Input Capacitance (system)</i>	1.8 pF	
<i>Input Coupling of the Measuring Instrument</i>	50 Ω	

Input Impedance

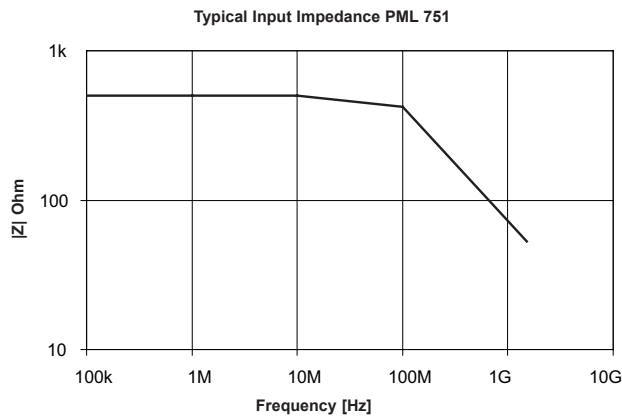

Note that the input impedance of the probe decreases as the frequency of the applied signal increases.

Mechanical Characteristics

Weight (probe only)	48 g
Cable Length	1.3 m
Probe Tip Diameter	2.5 mm

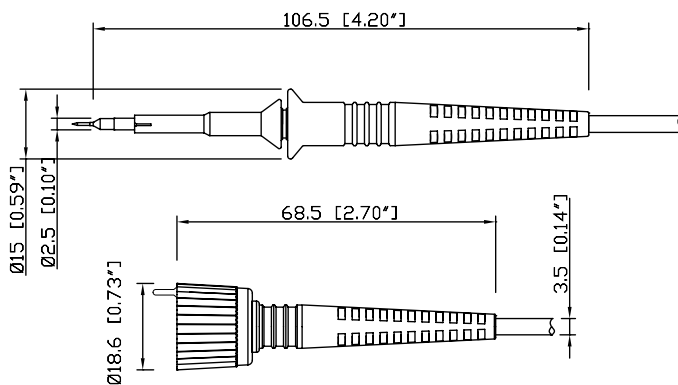



Environmental Specifications

<i>Altitude</i>	operating	up to 2000 m
	non-operating	up to 15000 m
<i>Temperature Range</i>	operating	0 °C to +50 °C
	non-operating	-40 °C to +71 °C
<i>Maximum Relative Humidity</i>	operating	80% relative humidity for temperatures up to +31 °C, decreasing linearly to 40 % at +50 °C

WEEE/ RoHS Directives

PMK electronic products are classified within the WEEE/ RoHS* category list as monitoring and control equipment (category 9). Category 9 products are exempt from the restrictions under the scope of the RoHS directive.

Your help and efforts are required to protect and keep clean our environment. Therefore return any electronic product at the end of its life either to Service Department of PMK Mess- und Kommunikationstechnik GmbH or take care of separate WEEE collection and professional WEEE treatment yourself. Do not dispose as unsorted municipal waste.

* EC Directives:

- | | | |
|---------------------------|---|---|
| WEEE Directive 2002/96/EC | – | Waste Electrical and Electronic Equipment |
| RoHS Directive 2002/95/EC | – | Restriction of the use of certain Hazardous Substances in Electrical and Electronic Equipment |



Scope of Delivery PML 751-RO Order No. 855-751-001

- 2 Footer Positioner
- 2x self adhesive Cu Pads
- Coding Rings (set) 3x4 colors
- Ground Blade 2.5
- Ground Lead 11 cm
- Ground Spring 2.5
- IC-Caps 0.5 to 1.27 mm pitch
- Instruction Manual
- Insulating Cap 2.5
- PCB Adapter Kit 2.5
- Probe
- Protection Cap 2.5
- Solid Tip CuBe 0.5 mm
- Spring Tip 0.5 mm
- Sprung Hook 2.5

Safety Information

To avoid personal injury and to prevent fire or damage to this product or products connected to it, review and comply with the safety informations stated in the manual before using this product. Be aware that if you use this probe assembly in a manner not specified the protection this product provides may be impaired.

Only qualified personnel should use this probe assembly.

Manufacturer

PMK Mess- und Kommunikationstechnik GmbH
Königsteiner Str. 98
65812 Bad Soden, Germany

Internet: www.pmk.de

Tel: +49 (0) 6196 5927 - 930

E-Mail: sales@pmk.de

Fax: +49 (0) 6196 5927 - 939