



PML 701-RO

High impedance passive probe

Features:

- 2.5 mm Diameter Tip
- Coaxial Design
- Interchangeable Spring Contact Tip
- IC Contacting System 0.5 to 1.27 mm pitch



The PML passive probe family sets new standards in high performance probing.

The compact design with only 2.5 mm housing diameter at the probe tip is ideal for measurements of SMT components. It provides a much better visibility over of the device under test as conventional 5 mm probe housing designs.

A true PMK GmbH feature the exchangeable probe tip is also available for the PML series. The gold plated spring contact or the rigid tip are only 0.5 mm in diameter. The tip replacement is easy and gives the engineer the best choice.

Particularly for HF measurements on IC's, a short as possible ground connection is recommendable. Due to long ground leads most conventional adaptations bring additional inductance and resonances into the measurement which will result in false or inaccurate readings. The innovative IC contacting system of the PML with 5 different IC adapters from 0.5 to 1.27 mm pitch in combination with the ground blade and IC ground copper pad is the ideal solution for short-circuit-safe, reproducible, and authentic measurements.

These great advantages and over 30 accessories parts for the new PML probe series will offer various configuration to solve most adaptation desires.

This datasheet supersedes all previously published material. Specifications that are not marked as guaranteed are published as general information to the user. The instrument should have warmed up for at least 20 minutes and the environmental conditions must not exceed the specified limits of the probe. Note that specifications are subject to change without notice.

Electrical Specifications

<i>Attenuation Ratio</i>	1:1
<i>System Bandwidth</i> ⁽¹⁾	38 MHz (-3 dB)
<i>System Risetime</i>	9 ns
	(10 % - 90 %) (typical)
<i>Maximum Rated Input Voltage</i> ⁽²⁾	55V rms CAT II
<i>Pollution Degree</i>	2

Electrical Characteristics

<i>Input Capacitance (System)</i>	39 pF + scope
<i>Input Coupling of the Measuring Instrument</i>	1 MΩ AC / DC

Mechanical Characteristics

Weight (probe only)	40 g
Cable Length	1.3 m
Probe Tip Diameter	2.5 mm

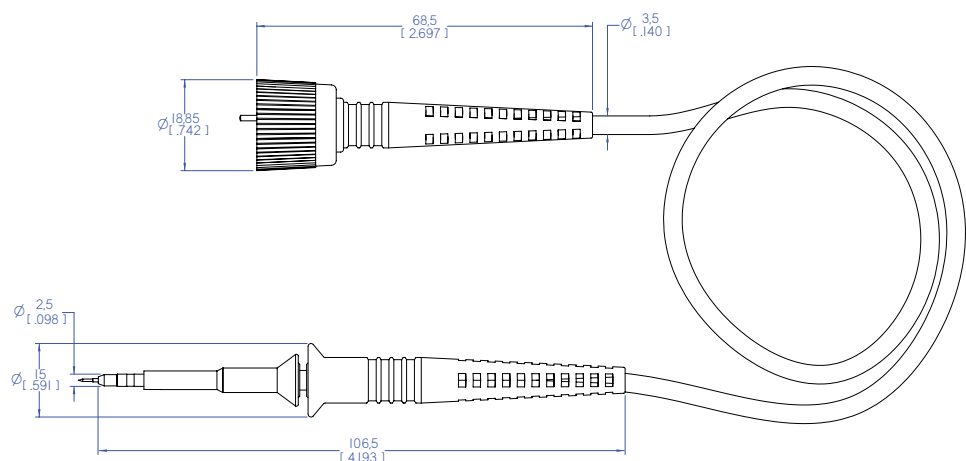

*) Units in millimeters [inch].
 (1) at 15 pF input capacitance of the measuring instrument.
 (2) As defined in IEC 61010-031



Environmental Specifications

<i>Altitude</i>	operating	up to 2000 m
	non-operating	up to 15000 m
<i>Temperature Range</i>	operating	0° C to +50° C
	non-operating	-40° C to +71° C
<i>Maximum Relative Humidity</i>	operating	80 % relative humidity for temperatures up to +31° C, decreasing linearly to 40 % at +50° C

Scope of Delivery PML 701-RO Order No. 855-701-00E

- Probe
- Ground Blade 2.5
- Ground Lead 15 cm
- Ground Spring 2.5
- IC-Caps 0.5 to 1.27 mm pitch
- Instruction Manual
- Insulating Cap 2.5
- Protection Cap 2.5
- Solid Tip CuBe 0.5 mm
- Spring Tip 0.5 mm
- Sprung Hook 2.5
- 2 Footer Positioner
- Coding Rings (Set) 3 x 4 colours
- PCB Adapter Kit 2.5
- 2 self adhesive Cu pads

Safety Information

To avoid personal injury and to prevent fire or damage to this product or products connected to it, review and comply with the safety informations stated in the manual before using this product. Be aware that if you use this probe assembly in a manner not specified the protection this product provides may be impaired.

Only qualified personnel should use this probe assembly.

Manufacturer

PMK Mess- und Kommunikationstechnik GmbH
Königsteiner Str. 98
65812 Bad Soden, Germany

Internet: www.pmk.de

Tel: +49 (0) 6196 5927 - 930
Fax: +49 (0) 6196 5927 - 939

E-Mail: sales@pmk.de