

# Spring Contact Probes



## Position Sensor System

**FEINMETALL**  
Contact Technologies



## Contact Probe with integrated travel measurement

### Position Sensor System

The Position Sensor System has been developed to enable an exact measurement of the travel additionally to contacting the test item.

To realize this, a small potentiometer is integrated in a dedicated position sensor that is screwed together with the contact probe and the receptacle. The 3-wire-circuit allows to realize a potential divider. After applying an operating voltage the sensor supplies a measurement voltage that is linear to the travel of the plunger. Alternatively, the resulting resistance can be used as measurement value.

The measurement results can be analyzed by the available tester environment, commonly.

#### Calibration

Due to test principle with a certain initial and final resistance and due to electrical and mechanical tolerances the exact plunger position in Millimeter requires a calibration of the Position Sensor System after assembly.

#### Measurement of relative values

By calculating the difference between two measurement values of one probe deviations related to a required position can be determined in positive or negative travel direction.

#### Reference measurement

By calculating the difference between two measurement values of different probes deviations related to a reference position can be determined. The reference probe can either touch a certain reference point of the test item or a special "golden device" can be used as a reference.

#### Zeroize

Depending on the hard and software of the test system the measurement signal can be zeroed at user-defined positions. This method allows positive or negative deviations without calculating differences.

**We recommend periodic calibration and zeroing.**

#### Modular design of the Position Sensor System, consisting of: Probe – Receptacle – Position Sensor

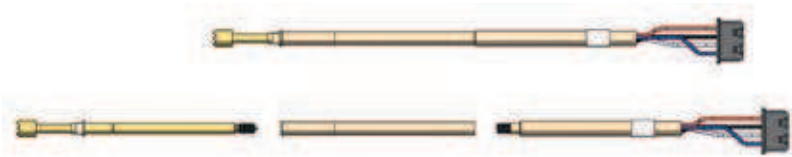

#### Specifications Position Sensor PS100F060R5.2:

Measuring range: 0...5.2 mm

Measuring principle: potentiometric

Accuracy:  $\pm 2\%$

Reproducibility: typ.  $\pm 0,05$  mm

Therm.resistance coeff.  $5 \times 10^{-5}/K$

Spring force: 60 cN

Preload: 40 cN

Nominal travel: 4.0 mm

Connections:

Red: Operating voltage  $U_o$

Black: Measurement signal  $U_m / R_m$

Blue: Test point contact probe (maximum current 1A)

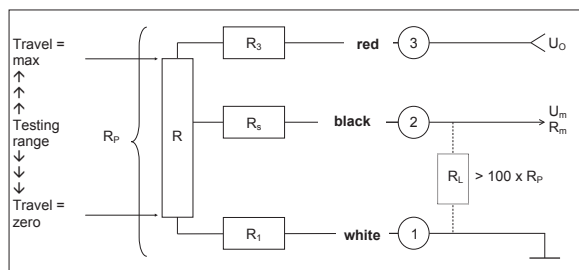

$U_o$  Operating voltage (maximum 20 VDC)

$U_m$  Potentiometric: Measurement voltage of potential divider ( $U_1 < U_m < U_p - U_3$ )

$R_m$  Resistive: Measurement resistance ( $R_1 < R_m < R_p - R_3$ )

$R_1$  Initial resistance (400 Ohm  $\pm$  200 Ohm)

$U_1$  Initial voltage ( $U_1 = I * R_1$ )

$R_3$  Final resistance

$U_3$  Final voltage ( $U_3 = I * R_3$ )

$R_p$  Potentiometer resistance (5 kOhm  $\pm$  20%) ( $R_p = R_1 + R + R_3$ )

$R_s$  Slider resistance

$R_L$  Load resistor (optional to protect against overcurrent at the slider)

#### Application example

The Position Sensor System allows the detection of pin lengths, component heights or the depth of drill holes.

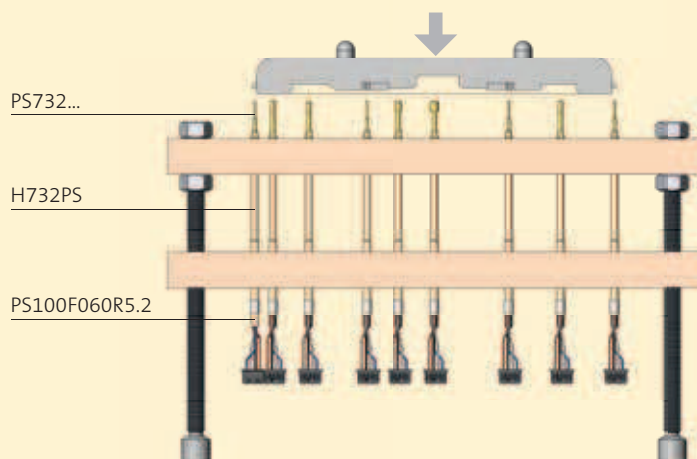

## Position Sensor System Twist Proof

### PS756

**NEW**

<b>Centers (mm/mil)</b>	2,54 / 100
<b>Current</b>	5,0 A
<b>Temperature</b>	-20°C...+80°C
<b>R typically</b>	50 mOhm

#### Spring Force (cN ±20%)

Preload	Nominal Force
30	90

#### Spring Forces for Complete System of PS756, H756PS and PS100 (cN ±20%)

Preload	Nominal Force
70	150

#### Travel (mm)

Nominal	Maximum
4,0	5,0
Thread (M)	1,6
Wrench Size	1,7
Pointing Accuracy	±0,08 mm

#### Materials and Plating

Plunger	see Tip Style
Barrel	Brass, gold plated
Spring	Music wire, silver plated
Receptacle	Brass, Gold plated

#### Accessories

Insertion tool receptacle	FAWZ756
Screw-in tool probe	FWZ732 (T)
Screw-in tool sensor	FWZPS100

#### Drill Size [mm]

H756PS	1,99 - 2,00
--------	-------------

#### Projection Height

H756PS	10,5
--------	------

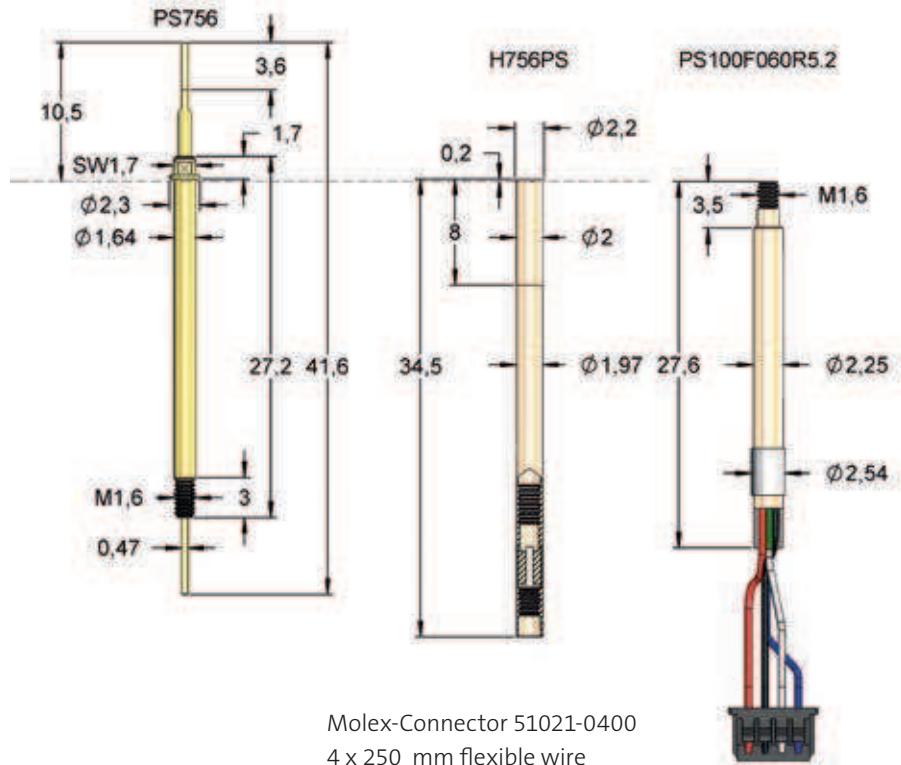

Molex-Connector 51021-0400  
4 x 250 mm flexible wire

The twist proof Position Sensor System consists of a special spring contact probe PS756, a receptacle H756PS and a sensor element PS100. These three elements are mounted into a fixture plate. The blue cable enables to connect the probe tip (test point). This solution allows a position test additionally to the electrical contact of the test item (maximum current 1 A).

Type	Tip-Ø	Spring Force
PS756 84 B 0001 G 090		
Tip Style	Material	Finish Special Version
Material: B = BeCu	Head-Ø: see table	Finish: G = Gold
For a Position Sensor System also receptacle and position sensor are necessary.		
<b>ORDER EXAMPLE</b>		

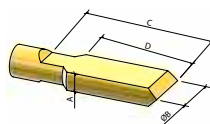

Tip Style	Numer	A	B	C	D	E	F	G	Version
84	0001	0,5	1,5	3,6	5,0	-	10,5	41,6	-