

### Features:

- Isolated mounting base 2500V~
- Pressure contact technology with  
Increased power cycling capability
- Space and weight savings

### Typical Applications

- Inverter
- Inductive heating
- Chopper

$$I_{T(AV)} \quad 150 \text{ A}$$

$$V_{DRM} / V_{RRM} \quad 600 \sim 1600 \text{ V}$$

$$I_{TSM} \quad 3.4 \text{ A} \times 10^3$$

$$I^2t \quad 58 \text{ A}^2 \text{ S} \times 10^3$$



SYMBOL	CHARACTERISTIC	TEST CONDITIONS	T <sub>j</sub> (°C)	VALUE			UNIT
				Min	Type	Max	
I <sub>T(AV)</sub>	Mean on-state current	180° half sine wave 50Hz Single side cooled, T <sub>c</sub> =85°C	115			150	A
I <sub>T(RMS)</sub>	RMS on-state current		115			236	A
V <sub>DRM</sub> V <sub>RRM</sub>	Repetitive peak off-state voltage Repetitive peak reverse voltage	V <sub>DRM</sub> &V <sub>RRM</sub> tp=10ms V <sub>DSM</sub> &V <sub>RSM</sub> = V <sub>DRM</sub> &V <sub>RRM</sub> +100V respectively	115	600		1600	V
I <sub>DRM</sub> I <sub>RRM</sub>	Repetitive peak current	at V <sub>DRM</sub> at V <sub>RRM</sub>	115			40	mA
I <sub>TSM</sub>	Surge on-state current	10ms half sine wave	115			3.4	KA
I <sup>2</sup> t	I <sup>2</sup> T for fusing coordination	V <sub>R</sub> =60%V <sub>RRM</sub>				58	A <sup>2</sup> s*10 <sup>3</sup>
V <sub>TO</sub>	Threshold voltage		115			0.85	V
r <sub>T</sub>	On-state slop resistance					1.66	mΩ
V <sub>TM</sub>	Peak on-state voltage	I <sub>TM</sub> =450A	25			1.78	V
dv/dt	Critical rate of rise of off-state voltage	V <sub>DM</sub> =67%V <sub>DRM</sub>	115			800	V/μs
di/dt	Critical rate of rise of on-state current	Gate source 1.5A t <sub>r</sub> ≤0.5μs Repetitive	115			200	A/μs
t <sub>q</sub>	Circuit commutated turn-off time	I <sub>TM</sub> = 150A, tp=1000μs, V <sub>R</sub> =50V dv/dt=30V/μs , di/dt=-20A/μs	115	15		35	μs
t <sub>rr</sub>	Reverse recovery time	I <sub>FM</sub> =150A, tp=1000μs, -di/dt=20A/μs, V <sub>R</sub> =50V	115		2.0		μs
I <sub>GT</sub>	Gate trigger current	V <sub>A</sub> =12V, I <sub>A</sub> =1A	25	30		180	mA
V <sub>GT</sub>	Gate trigger voltage			1.0		2.5	V
I <sub>H</sub>	Holding current			20		100	mA
V <sub>GD</sub>	Non-trigger gate voltage	V <sub>DM</sub> = 67%V <sub>DRM</sub>	115	0.2			V
R <sub>th(j-c)</sub>	Thermal resistance Junction to case	Single side cooled				0.140	°C /W
R <sub>th(c-h)</sub>	Thermal resistance case to heatsink	Single side cooled				0.04	°C /W
V <sub>iso</sub>	Isolation voltage	50Hz, R.M.S, t=1min, I <sub>iso</sub> : 1mA(MAX)		2500			V
F <sub>m</sub>	Thermal connection torque(M8)				12		N·m
	Mounting torque(M6)				6		N·m
T <sub>stg</sub>	Stored temperature			-40		125	°C
W <sub>t</sub>	Weight				860		g
Outline	413F3						

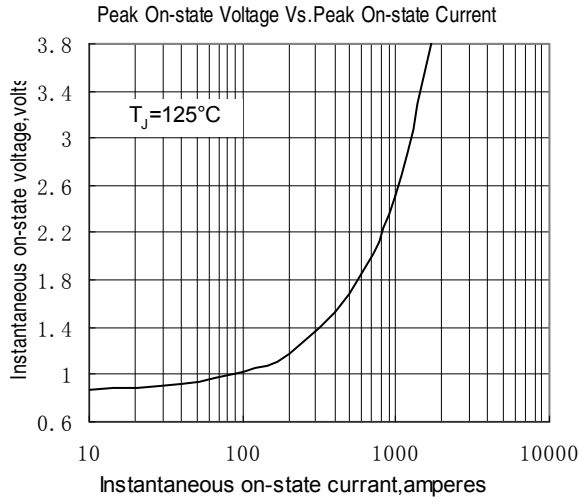

Fig.1

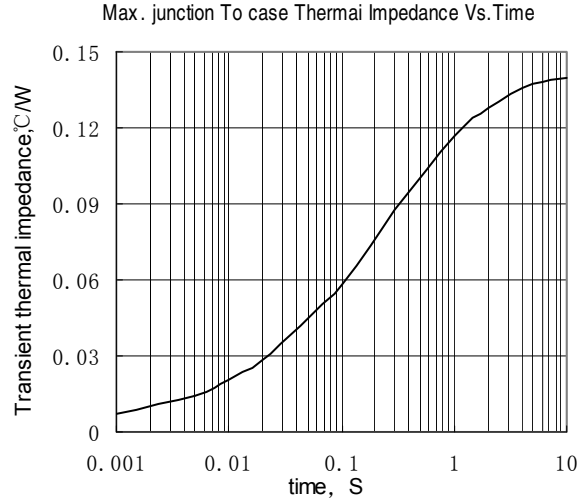

Fig.2

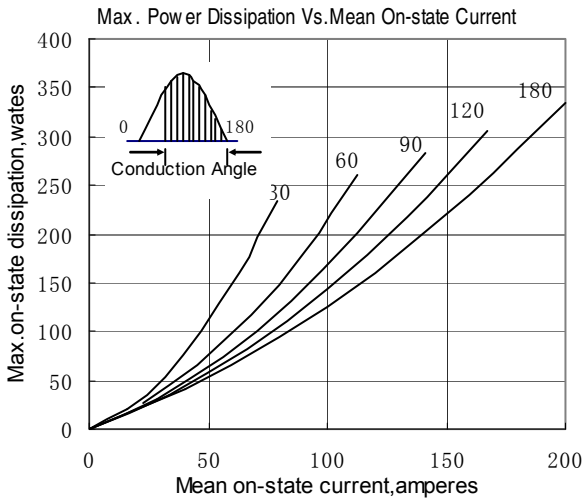

Fig.3

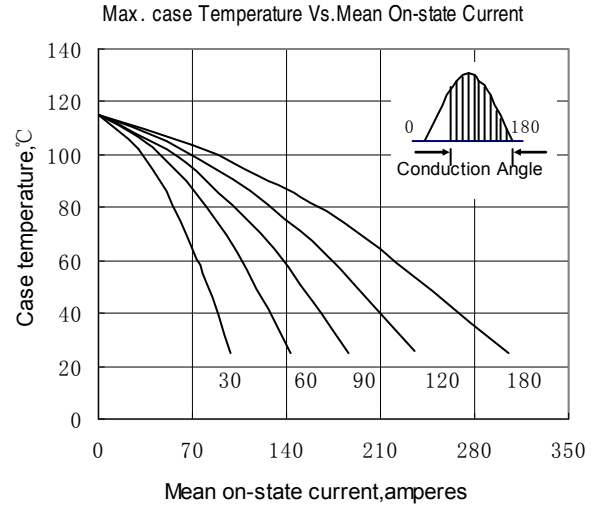

Fig.4

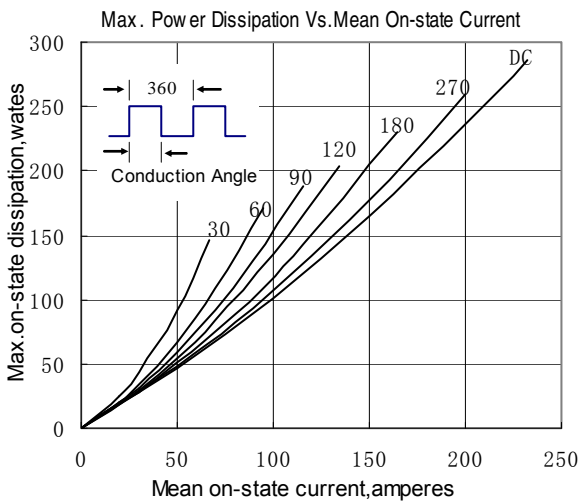

Fig.5

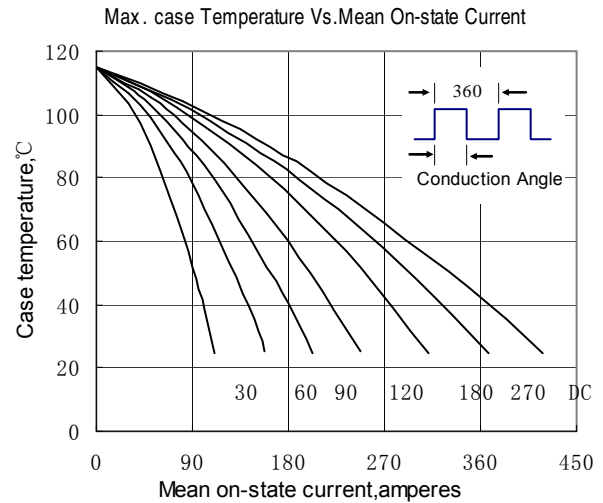

Fig.6

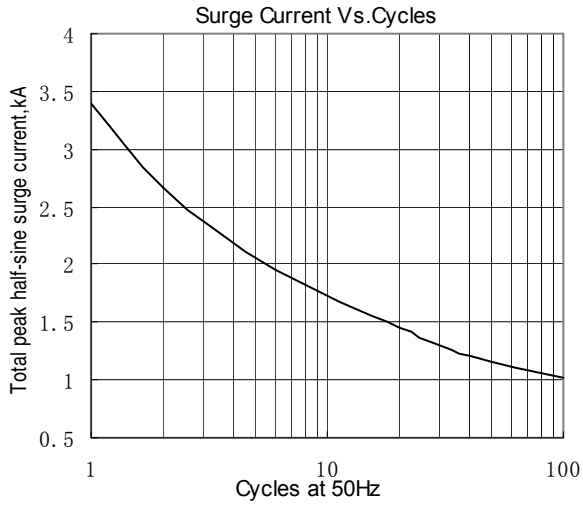

Fig.7

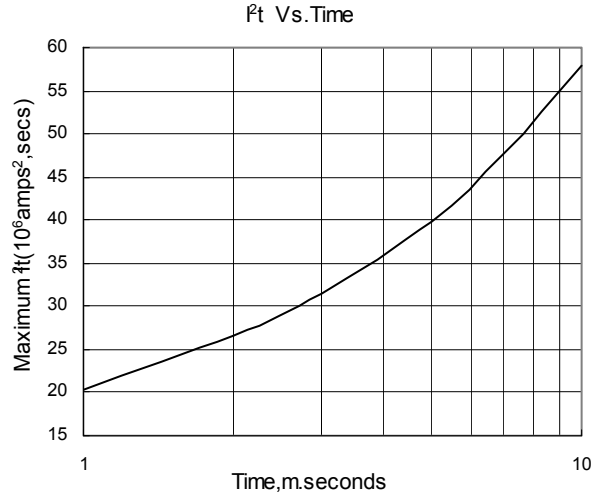

Fig.8

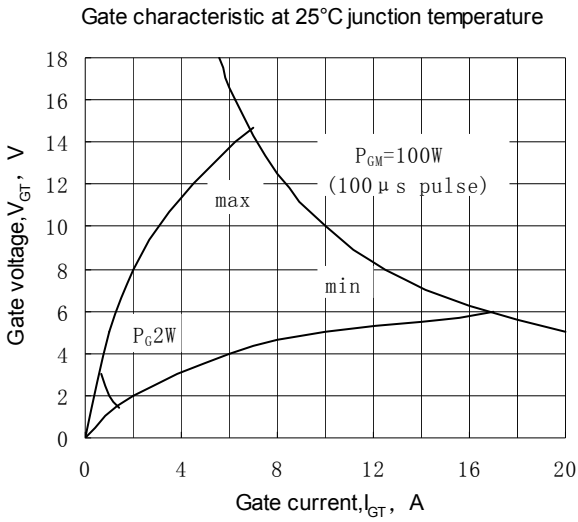

Fig.9

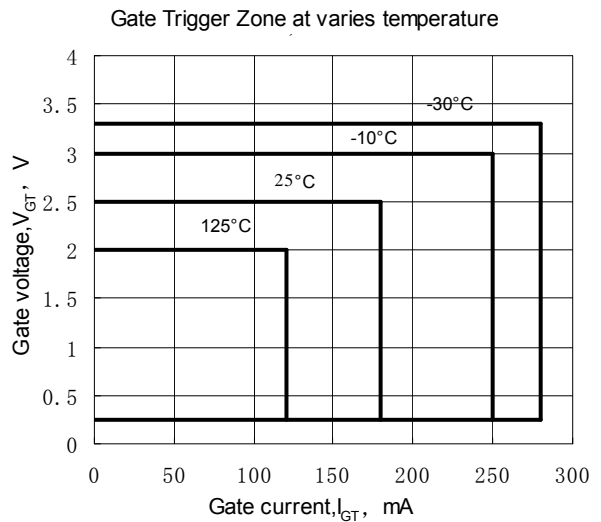
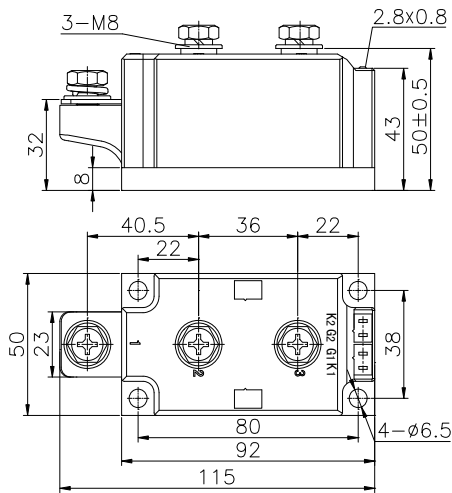

Fig.10

**Outline:**



**413F3**

