

### Features:

- Isolated mounting base 2500V~
- Pressure contact technology with  
Increased power cycling capability
- Space and weight savings

### Typical Applications

- AC/DC Motor drives
- Various rectifiers
- DC supply for PWM inverter

$I_{F(AV)}$       **500A**  
 $V_{RRM}$         **600~1800V**  
 $I_{FSM}$          **18A×10<sup>3</sup>**  
 $I^2t$              **1620A<sup>2</sup> S×10<sup>3</sup>**



SYMBOL	CHARACTERISTIC	TEST CONDITIONS	T <sub>j</sub> (°C)	VALUE			UNIT
				Min	Type	Max	
I <sub>F(AV)</sub>	Mean forward current	180° half sine wave 50Hz Single side cooled, T <sub>C</sub> =100°C	150			500	A
I <sub>F(RMS)</sub>	RMS forward current		150			785	A
V <sub>RRM</sub>	Repetitive peak reverse voltage	V <sub>RRM</sub> tp=10ms V <sub>RSM</sub> = V <sub>RRM</sub> +100V	150	600		1800	V
I <sub>RRM</sub>	Repetitive peak current	at V <sub>RRM</sub>	150			40	mA
I <sub>FSM</sub>	Surge forward current	10ms half sine wave	150			18	KA
I <sup>2</sup> t	I <sup>2</sup> T for fusing coordination	V <sub>R</sub> =0.6V <sub>RRM</sub>					1620
V <sub>FO</sub>	Threshold voltage		150			0.75	V
r <sub>F</sub>	Forward slop resistance						0.30
V <sub>FM</sub>	Peak forward voltage	I <sub>FM</sub> =1500A	25			1.45	V
R <sub>th(j-c)</sub>	Thermal resistance Junction to case	At 180°sine' Single side cooled				0.090	°C /W
R <sub>th(c-h)</sub>	Thermal resistance case to heatsink	At 180° sine' Single side cooled				0.024	°C /W
V <sub>iso</sub>	Isolation voltage	50Hz, R.M.S, t=1min, I <sub>iso</sub> :1mA(max)		2500			V
F <sub>m</sub>	Terminal connection torque(M10)				12		N·m
	Mounting torque(M6)				6		N·m
T <sub>stg</sub>	Stored temperature			-40		125	°C
W <sub>t</sub>	Weight				1500		g
Outline	416F3						

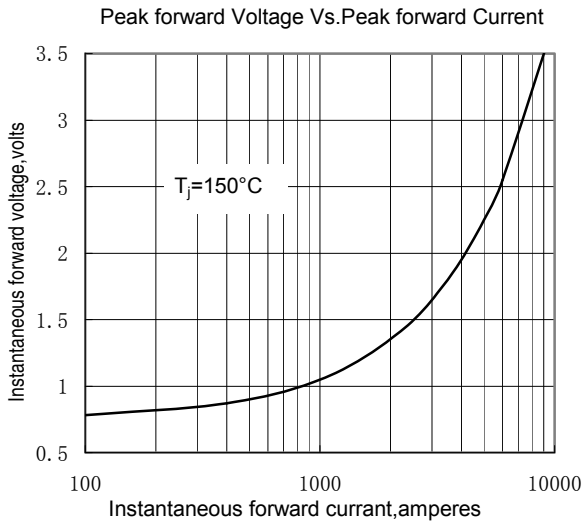

Fig.1

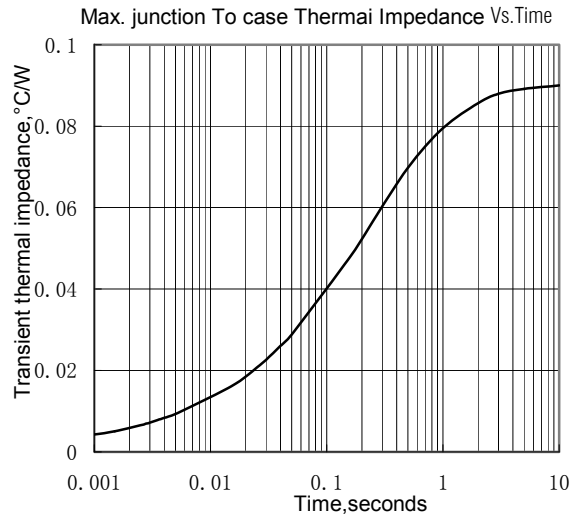

Fig.2

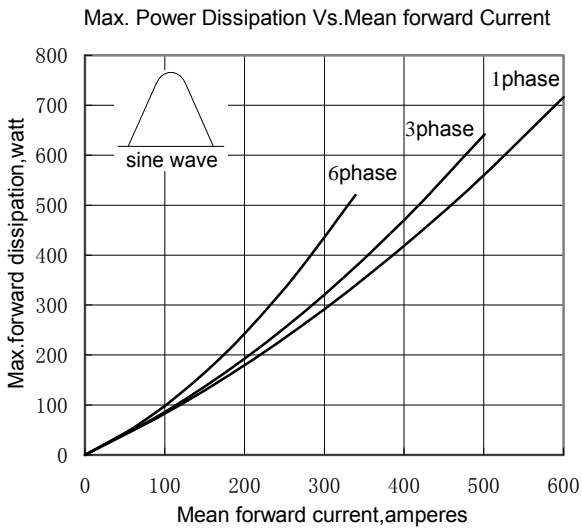

Fig.3

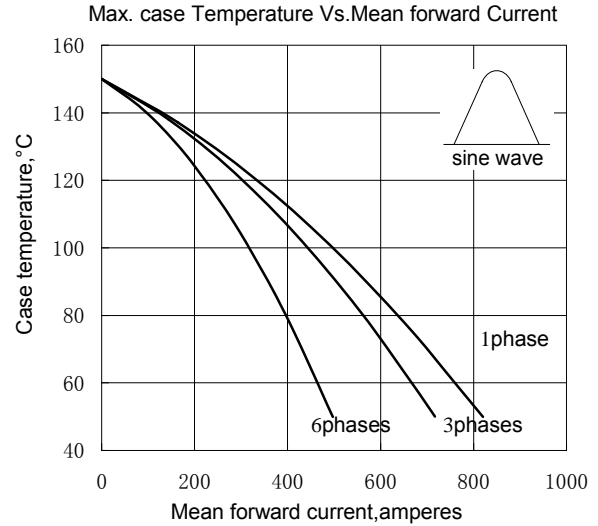

Fig.4

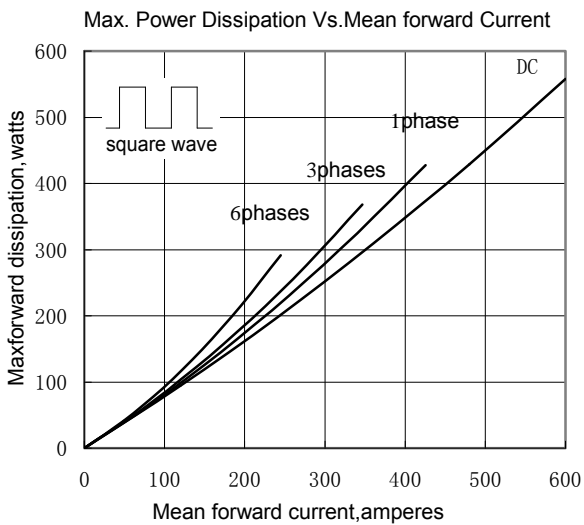

Fig.5

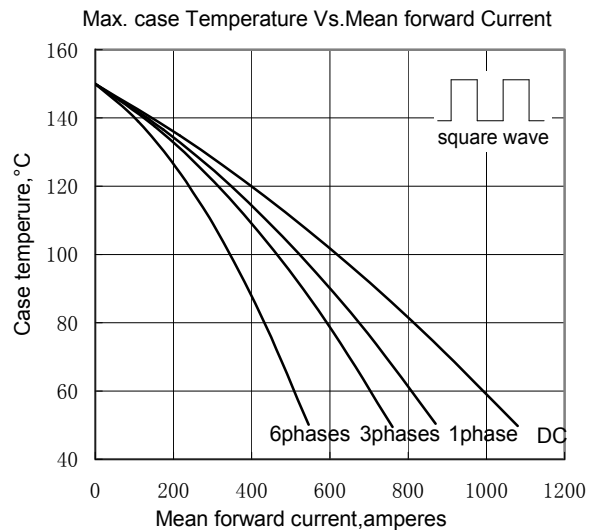
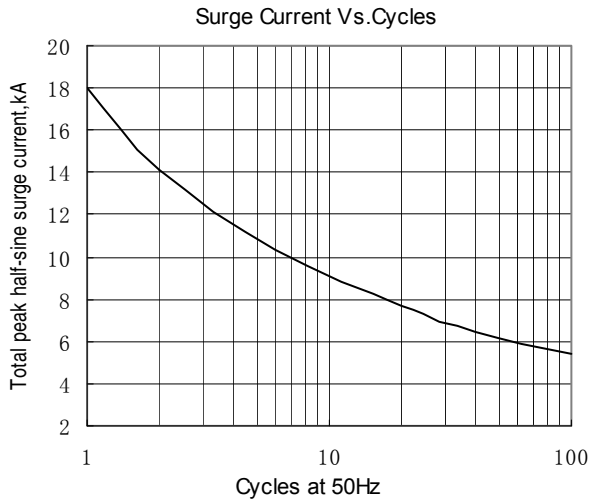
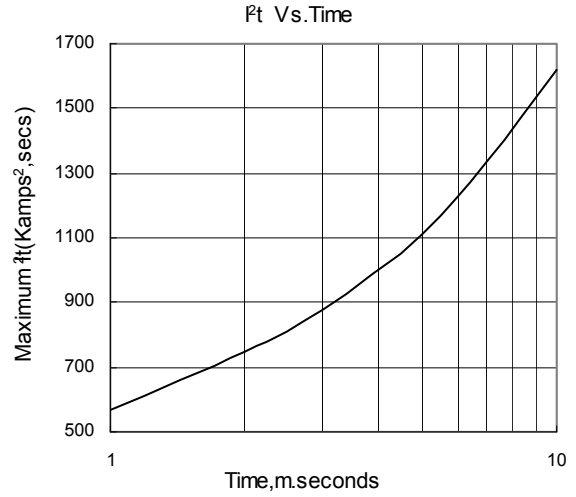

Fig.6

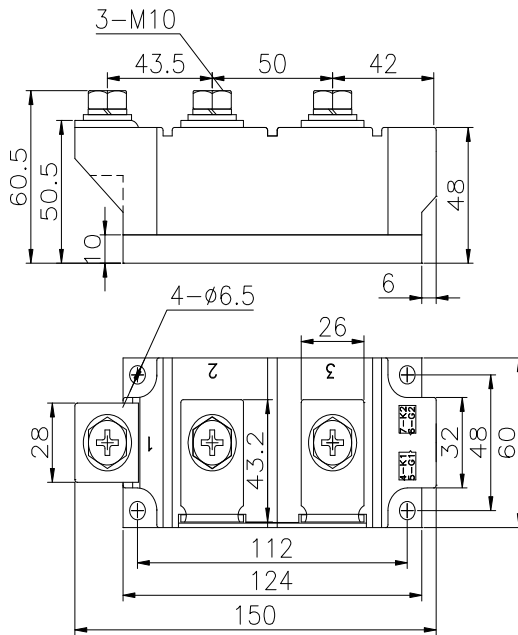

**Fig.7**



**Fig.8**

**Outline:**



**416F3**

