

Thermally enhanced Low V_{FB} Step-Down LED Driver

ADT6780

General Description

The ADT6780 is a thermally enhanced current mode step down LED driver. That is designed to deliver constant current to high power LEDs. The device is suitable for various high power LED application due to the wide operating range(V_{IN} 4.5V~28V) and high output capability(continuous 2A). with a very low feedback voltage($V_{FB}=0.2V$) power dissipation can be minimized. Fault condition protection includes cycle-by-cycle current limiting and thermal shutdown.

The package is available in a standard SOP8-PP(with Exposed pad) package.

Features

- Feedback reference voltage : 0.2V
- Current mode buck LED driver with 925kHz fixed frequency
- Input voltage range : 4.5V to 28V
- Continuous output current : 2A
- Up to 93% efficiency
- Integrated Power MOSFET switch : 80m Ω
- 10 μ A shutdown mode
- Thermal shutdown & current limit protection
- Under Voltage LOckout

Applications

- High power LED/IR-LED Lighting
- Automotive and Marine Lighting
- Architecture Lighting
- General Lighting Solutions

Typical Application Circuit

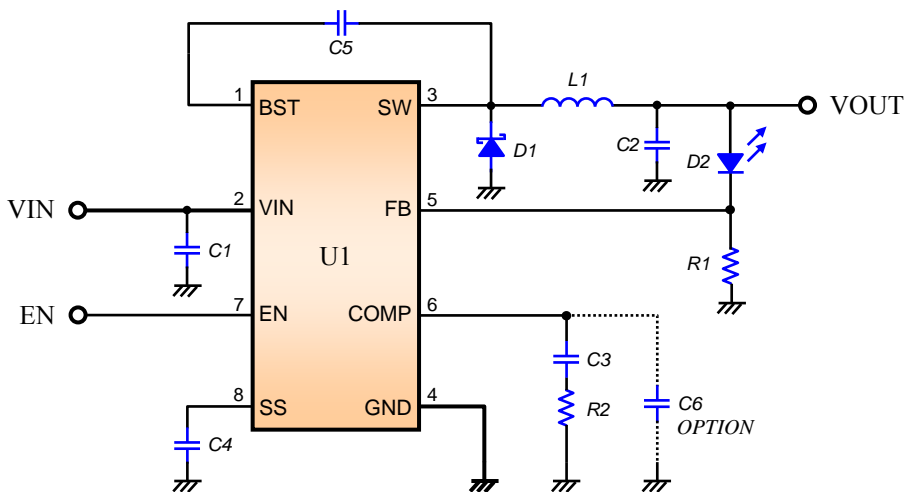

Figure 1. Typical Application Circuit

* This specifications are subject to be changed without notice

Part List

Component	Type	Value (Model)	Manufacturer
U1	IC	ADT6780	ADTech
D1	Schottky Barrier Diode	B230A	DIODES
L1	Chip inductor	6.8uH / 3A	TDK
C1	MLCC	10 μ F / 35V	-
C2	MLCC	10 μ F / 10V	-
C3	MLCC	8.2nF	-
C4	MLCC	100nF	-
C5	MLCC	10nF	-
R1	Chip resistor	0.2 Ω / 1%	-
R2	Chip resistor	2k Ω	-

Pin Description

Pin No.	Name	Description
1	BST	High-Side Gate Drive Boost Input. This pin acts as the power supply of high-side gate driving blocks. Connect a 10nF or greater capacitor between SW and BST pin.
2	VIN	Power supply input. Bypass VIN to GND with a suitably large capacitor to eliminate noise on the input to the IC.
3	SW	Switching node. The free-wheeling diode is connected between SW and GND.
4	GND	Ground. Connect the exposed pad on backside to GND.
5	FB	Feedback voltage input. The regulated FB voltage is 0.2V typically.
6	COMP	Compensation node. COMP is used to compensate the regulation control loop.
7	EN	Chip enable input. Also this pin functions UVLO input.
8	SS	Soft start control node. This pin controls the soft start period.

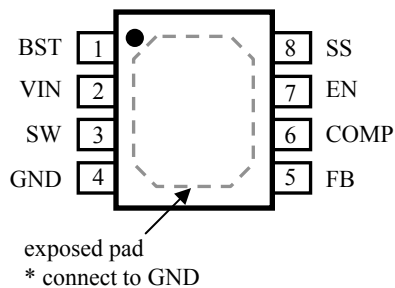

Package outline

** This specifications are subject to be changed without notice*

Electrical Characteristics ($T_a=25^\circ\text{C}$, $V_{IN}=12\text{V}$, unless otherwise noted)

Parameters	Symbol	Condition	Min.	Typ.	Max.	Unit
Supply current (shutdown)	I_{OFF}	$V_{EN} = 0\text{V}$	-	10	19	μA
Supply current (quiescent)	I_Q	$V_{EN} = 3\text{V}$, $V_{FB} = 1.4\text{V}$	-	0.7	1.0	mA
Feedback voltage	V_{FB}	$4.5\text{V} \leq V_{IN} \leq 28\text{V}$, $V_{COMP} < 2\text{V}$	0.184	0.200	0.216	V
Error Amplifier Voltage Gain (Note4)	A_{EA}	-	-	750	-	V/V
Error Amplifier Transconductance	G_{EA}	$\Delta I_{COMP} = \pm 10\mu\text{A}$	-	750	-	$\mu\text{A/V}$
High-Side Switch On Resistance (Note4)	$R_{ON,H}$	-	-	80	-	$\text{m}\Omega$
Low-Side Switch On Resistance (Note4)	$R_{ON,L}$	-	-	10	-	Ω
High-Side Switch Leakage Current		$V_{EN} = 0\text{V}$, $V_{SW} = 0\text{V}$	-	0.1	10	μA
Peak Current Limit		Duty=50%	-	3	-	A
Current sense to COMP transconductance	G_{CS}	-	-	6	-	A/V
Oscillator frequency	F_{SW}	-	-	925	-	kHz
Fold-back frequency		$V_{FB} = 0\text{V}$	-	125	-	kHz
Maximum Duty cycle	D_{MAX}	$V_{FB} = 0.15\text{V}$, $I_O=1\text{A}$	76	86	99	%
Minimum On time	T_{ON}	-	-	100	-	ns
UVLO rising threshold		V_{EN} rising	2.00	2.35	2.70	V
UVLO threshold hysteresis		-	-	250	-	mV
EN threshold voltage		-	0.8	1.1	-	V
Enable pull-up current		$V_{EN} = 0\text{V}$	-	2.0	-	μA
Soft-Start Period		$C4 = 100\text{nF}$	-	3	-	ms
Thermal shutdown (Note4)		-	-	145	-	$^\circ\text{C}$

Note4. guaranteed by design.

** This specifications are subject to be changed without notice*

Typical Operating Characteristics

$V_{IN}=12V$, Load : 1A / one 4W White LED and $T_a=25^\circ C$, unless otherwise noted

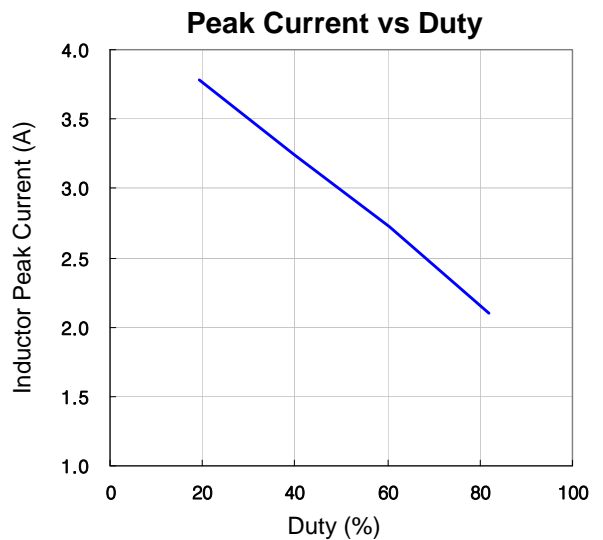
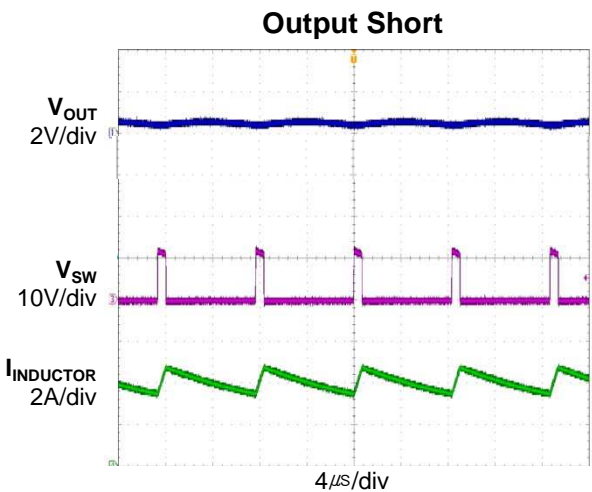
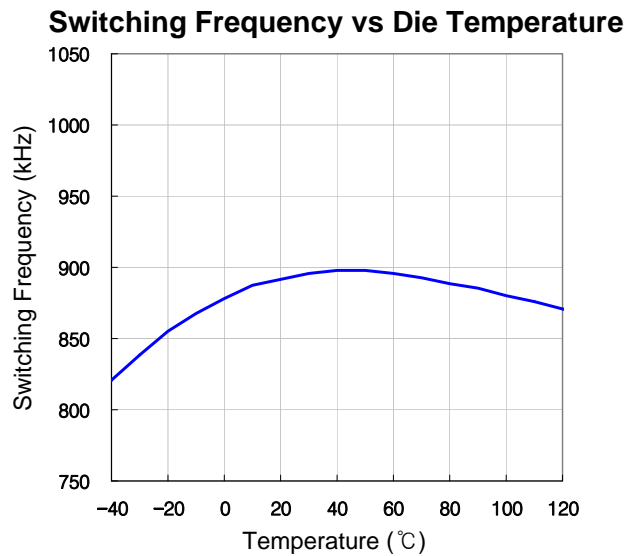
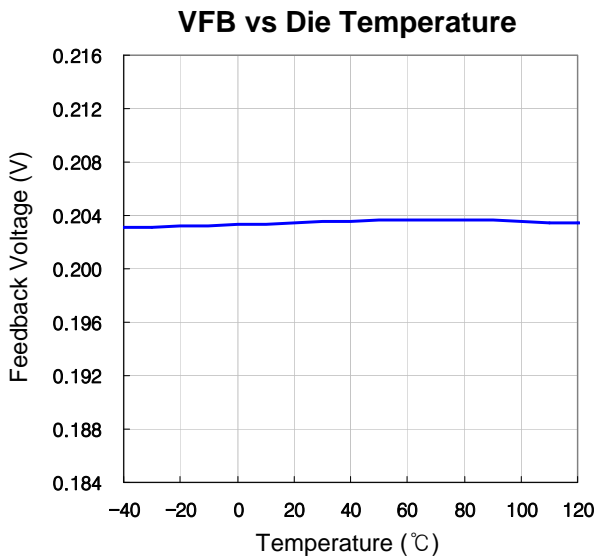
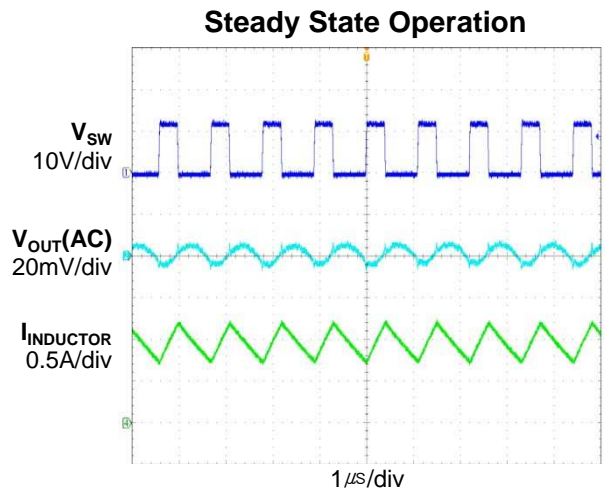
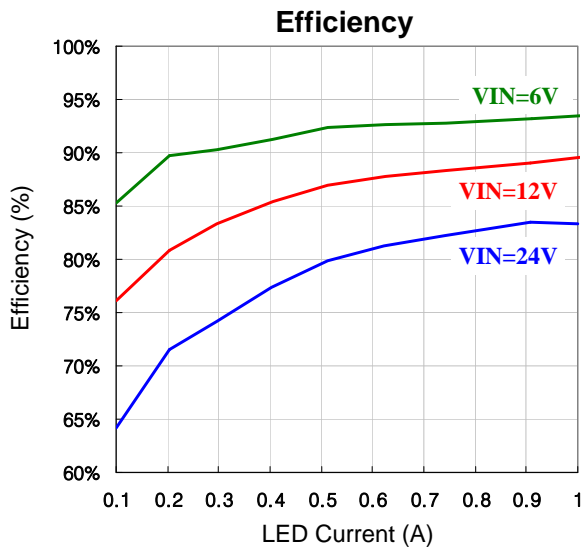

* This specifications are subject to be changed without notice

Typical Operating Characteristics

$V_{IN}=12V$, Load : 1A / one 4W White LED and $T_a=25^{\circ}C$, unless otherwise noted

Enable Start-up
($C_4=100nF$)

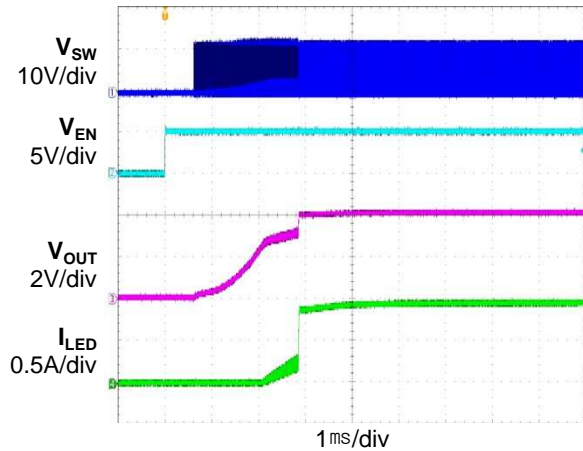

Enable Turn-off
($C_4=100nF$)

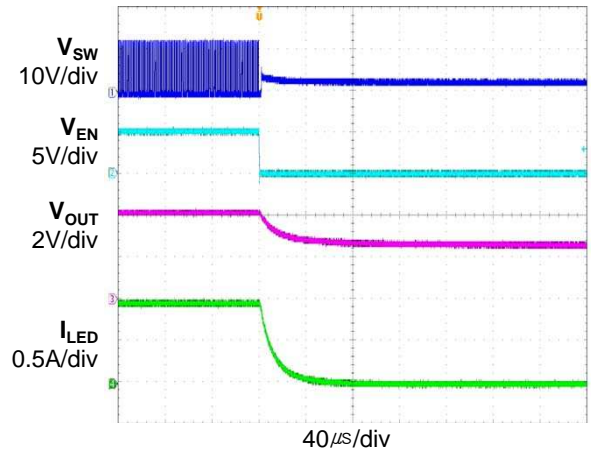

Enable Start-up
(C_4 open)

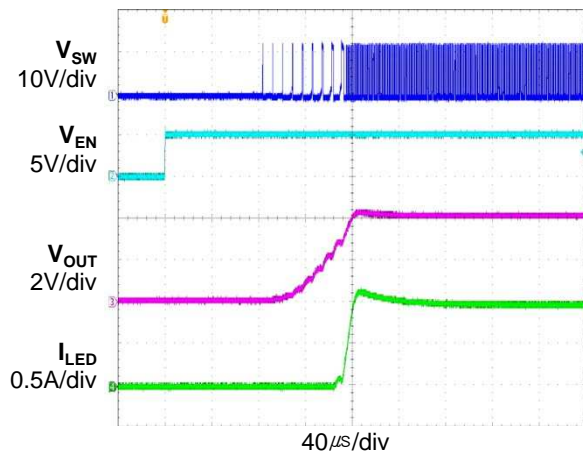

Enable Turn-off
(C_4 open)

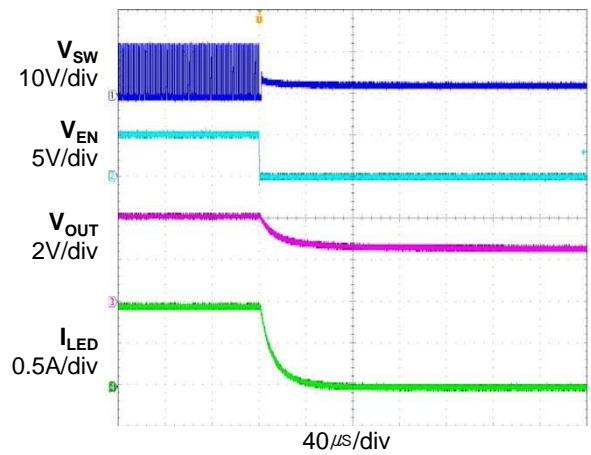

PWM Dimming Through Enable
(C_4 open, PWM Frequency=500Hz, Duty=50%)

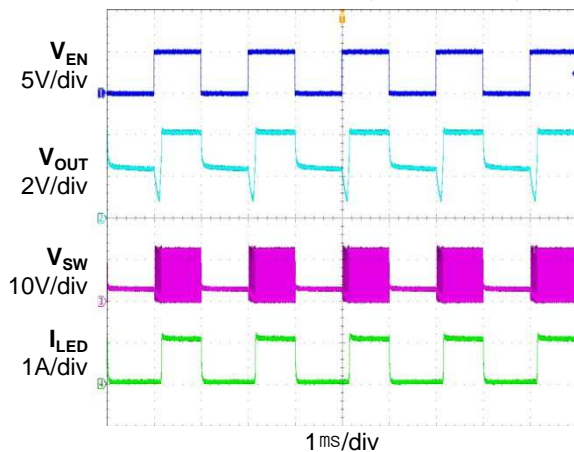

LED Current vs PWM Dimming Duty
(C_4 open, PWM Frequency=500Hz)

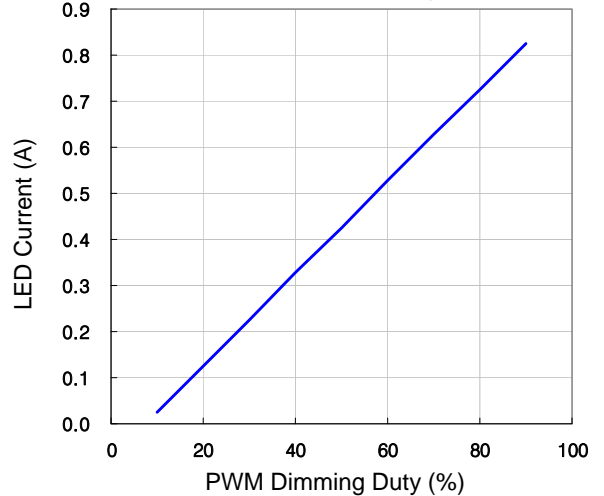

* This specifications are subject to be changed without notice

OVERVIEW

The ADT6780 is a current mode step-down converter with integrated high side NMOS power switch. It operates from a 4.5V to 28V input voltage range and supplies up to 2A of load current. Features include enable control, under voltage lockout, programmable soft start, current limit, thermal shutdown and PWM dimming of LEDs. The ADT6780 uses current mode control to regulate the LED current. The LED current is measured at FB pin voltage and amplified through the internal error amplifier. The error amplifier output voltage is used to control the high side NMOS power switch and consequently LED current is regulated.

DETAILED DESCRIPTION

Enable and Soft Start

EN pin of the ADT6780 operates both chip enable and UVLO function. EN pin voltage under 800mV shuts down all the chip function except for pulling up EN pin. When the EN pin voltage exceeds 1.1V, the internal regulator will be enabled. A EN pin voltage over 2.7V, the soft start capacitor will begin to charge and enables all the operations including switching function. When the EN pin is floating, EN voltage is high for its pull-up function.

The soft start function is adjustable. When the EN pin becomes high, a tens of μA current begins charging the capacitor which is connected from the SS pin to GND. Smooth control of the output voltage is maintained during start up. The soft start time is adjusted by changing capacitance of C4 and the typical soft start time is 3msec at 100nF of C4.

Switching Frequency

The ADT6780 switching frequency is fixed and set by an internal oscillator. The practical switching frequency could range from 777kHz to 1050kHz due to device variation. If the FB voltage is under 80mV, the switching frequency is changed to 125kHz for reducing abrupt inrush current.

Power Boosting

The ADT6780 uses an internal NMOS power switch to step-down the input voltage to the regulated output current. Since the NMOS power switch requires a gate voltage greater than the input voltage, a boost capacitor connected between SW and BST drives the gate. The capacitor is internally charged when SW is low.

Error Amplifier

The high gain error amplifier extracts the difference between the reference voltage and the feedback voltage. This extracted difference, called error signal, amplified and fed into the COMP, which is for compensation. The feedback voltage is regulated to the reference voltage, typical 0.2V for the ADT6780.

Current Sensing

The current sensing output is proportional to the current flowing into the inductor, This output goes to the comparator to make a proper PWM control signal. This output waveform resembles normally ramp shape.

Current Limit Protection

The output over-current protection (OCP) is implemented using a cycle-by-cycle peak detect control circuit. The switch current is monitored by measuring the high side NMOS switch current. The measured switch current is compared against a preset voltage which represents the current limit, between 2.2A and 4A. When the output current is more than current limit, the high side switch will be turned off and PWM duty is reduced. The output current is monitored in the same manner at each cycle and finally the power switch almost turned off not to be damaged under fault conditions.

** This specifications are subject to be changed without notice*

LED PWM Dimming

The LED brightness can be controlled by applying a pulse-width modulation(PWM) signal to the EN pin. PWM frequency is limited by turn-on and turn-off time of the LED current. So, Using a PWM dimming application, soft-start time control capacitor, C4 is not used for higher PWM dimming frequency. PWM frequency is recommended in range of 100Hz to 1kHz to get a good dimming linearity.

APPLICATION INFORMATION

Figure 1 is the typical ADT6780 application circuit. And Figure 2 is the functional block diagram of the ADT6780. For the application information, refer to the Figure 1 & 2 unless otherwise noted.

LED Current Resistor Selection

The LED current is set with a current sense resistor R1 between FB and GND. It is recommended to use 1% tolerance or better resistor. LED current is calculated by the below equation.

$$I_{LED} = \frac{0.2V}{R1}$$

For 1A LED current, choose $R1 = 0.2\Omega$

Inductor

The inductor required to supply constant current to the output load when it is driven by a switching voltage. For given input and output voltage, inductance and switching frequency together decide the inductor ripple current, that is:

$$\Delta I_L = \frac{V_{OUT}}{F_{SW} \times L} \times \left(1 - \frac{V_{OUT}}{V_{IN}} \right)$$

The peak inductor current is:

$$I_{L,peak} = I_{OUT} + \frac{\Delta I_L}{2}$$

Higher inductance gives low inductor ripple current but requires larger size inductor to avoid saturation. Low ripple current reduces inductor core losses. Also it reduces RMS current through inductor and switches, which results in less conduction loss. Usually, peak to peak ripple current on inductor is designed to be 20% to 30% of the output current limit. Make sure it is capable to handle the peak current without saturation.

Surface mount inductors in different shape and styles are available from TDK, TOKO and Murata. Shielded inductors are small and radiate less EMI noise. But they cost more than unshielded inductors. The choice depends on EMI requirement, price and size.

Output Freewheeling Diode

When the high side switch is off, freewheeling diode supplies the current to the inductor. The forward voltage and reverse recovery times of the freewheeling diode are the key loss factors, so schottky diode is mostly used for the freewheeling diode. Choose a diode whose maximum reverse voltage rating is greater than the maximum input voltage, and whose current rating is greater than the maximum load current.

** This specifications are subject to be changed without notice*

APPLICATION INFORMATION (continued)

Input Capacitor

The input capacitor is used to filter out discontinuous, pulsed input current and to maintain input voltage stable. Therefore input capacitor should be able to supply the AC current to the step-down converter. Its input ripple voltage can be estimated by:

$$\Delta V_{IN} = \frac{I_{OUT}}{F_{SW} \times C_{IN}} \times \frac{V_{OUT}}{V_{IN}} \times \left(1 - \frac{V_{OUT}}{V_{IN}}\right)$$

where, C_{IN} is input capacitor value.

The voltage rating of input capacitor must be greater than the maximum input voltage plus ripple voltage.

Since the input capacitor absorbs the input switching current, it requires an proper ripple current rating. The RMS current in the input capacitor can be approximated by:

$$I_{CIN_RMS} = I_{OUT} \times \sqrt{\frac{V_{OUT}}{V_{IN}} \times \left(1 - \frac{V_{OUT}}{V_{IN}}\right)}$$

The worst-case condition occurs at $V_{IN}=2 \times V_{OUT}$ (50% duty condition), and its worst RMS current is approximately half of the I_{OUT} . For reliable operation and best performance, the input capacitors must have current rating higher than I_{CIN_RMS} at worst operating conditions. Ceramic capacitors are preferred for input capacitors because of their low ESR and high current rating. When selecting ceramic capacitors, X5R or X7R type dielectric ceramic capacitors should be used for their better temperature and voltage characteristics. For most applications, a $10\mu F$ ceramic capacitor is sufficient.

Output Capacitor

The output capacitor is required to maintain the DC output voltage. In a step-down converter circuit, output ripple voltage is determined by the inductor value, switching frequency, output capacitor value and ESR. That is:

$$\Delta V_{OUT} = \Delta I_L \times \left(ESR + \frac{1}{8 \times F_{SW} \times C_O}\right)$$

where,

C_O is output capacitor value,

ESR is the equivalent series resistance of the output capacitor.

Low ESR capacitors are preferred to keep the output voltage ripple low. When low ESR ceramic capacitor is used as output capacitor, its ESR value can be waived. So, the impedance at the switching frequency is dominated by the capacitance. Therefore the output voltage ripple is:

$$\Delta V_{OUT} = \Delta I_L \times \left(\frac{1}{8 \times F_{SW} \times C_O}\right)$$

On the other hand, in the case of tantalum or electrolytic capacitors, the ESR dominates the impedance at the switching frequency. In this case, the output voltage ripple is:

$$\Delta V_{OUT} = \Delta I_L \times (ESR)$$

In a step-down converter, output capacitor current is continuous. Usually, the ripple current rating of the output capacitor is not concerned because of its low ripple current. For most applications, a $10\mu F$ ceramic capacitor is sufficient.

** This specifications are subject to be changed without notice*

APPLICATION INFORMATION (continued)

Loop Compensation

The ADT6780 uses a fixed frequency, peak current mode control scheme to provide easy compensation and fast transient response. Peak current mode control eliminates the double pole effect of the output LC filter. Therefore, the step-down converter can be simplified to be a one-pole system in frequency domain.

The goal of compensation design is to shape the converter transfer function to get the desired gain and phase. System stability is provided with the addition of a simple series capacitor-resistor from COMP to GND. This pole-zero combination serves to adjust the desired response of the closed-loop system.

The DC gain of the voltage feedback loop is given by:

$$A_{VDC} = R_1 \times A_{EA} \times G_{CS}$$

Where A_{EA} is the error amplifier voltage gain. G_{CS} is the current sense transconductance and R_1 is the current sense resistor value.

The system has two dominant poles. One is made by the combination of both the output resistor of the error amplifier and the compensation capacitor (C3). And the other is due to the output capacitor and the LED's AC resistor ($R_{LED} = \Delta V_{OUT} / \Delta I_{LED}$). These poles are expressed as:

$$f_{p1} = \frac{G_{EA}}{2\pi \times C3 \times A_{EA}}$$

$$f_{p2} = \frac{1}{2\pi \times C_O \times R_{LED}}$$

where, G_{EA} is the error amplifier transconductance.

For a stable one-pole converter system, one of two dominant poles needs to be eliminated by one zero. One zero made by the series capacitor-resistor (R2-C3) cancels f_{p2} out. This zero is:

$$f_{z1} = \frac{1}{2\pi \times C3 \times R2}$$

If the output capacitor has a large capacitance and/or a high ESR value, unwanted zero is generated to the location of:

$$f_{z2} = \frac{1}{2\pi \times C_O \times ESR}$$

In this case, third pole is needed to compensate f_{z2} . This pole, f_{p3} , is made by the R2 and the selectively added optional capacitor (C6) between COMP to GND. f_{p3} is expressed to:

$$f_{p3} = \frac{1}{2\pi \times C6 \times R2}$$

The system crossover frequency (F_c), where the feedback loop has the unity gain, is important. The system crossover frequency is called the converter bandwidth. Generally higher F_c means faster transient response and load regulation. However, higher F_c could cause system unstable. A standard rule of thumb sets the crossover frequency to be equal or less than 1/10 of switching frequency.

** This specifications are subject to be changed without notice*

APPLICATION INFORMATION (continued)

Table1 and Table2 list the typical values of compensation components and external components for general applications.

Table 1. Components values for IRLED application (Refer to the Typical Application Circuit, for other components.)

VIN (V)	# of series IRLEDs	VOUT _{MAX} (V)	R2 (k Ω)	C3 (nF)	C6 (pF)	L1 (uH)	C2 (μ F)
12	1 ~ 5	10	2	8.2	None	6.8 ~ 10	10
24	1 ~ 8	16	2	8.2	None	15 ~ 22	10

Table 2. Components values for WLED application (Refer to the Typical Application Circuit, for other components.)

VIN (V)	# of series WLEDs	VOUT _{MAX} (V)	R2 (k Ω)	C3 (nF)	C6 (pF)	L1 (uH)	C2 (μ F)
12	1 ~ 2	8	2	8.2	None	6.8 ~ 10	10
24	1 ~ 4	16	2	8.2	None	15 ~ 22	10

The output voltage is calculated by the below equation.

$$V_{OUT} = n \times V_F + V_{FB}$$

Where, n is the number of LEDs connected in series, VF is the forward voltage of the LED and VFB is the voltage drop across the current sense resistor.

A general procedure to choose the compensation components for conditions is following:

1. Select the desired crossover frequency. Set the crossover frequency to be equal or less than 1/10 of switching frequency.
2. Select R2 (compensation resistor) to operate the desired crossover frequency in a given condition. R2 value is calculated by the following equation:

$$R2 = \frac{2\pi \times F_C \times C2 \times R_{LED}}{G_{EA} \times G_{CS} \times R1}$$

3. Select C3 (compensation capacitor) to achieve the desired loop phase margin. C3 determines the desired first system zero, f_{z1} . Typically, set f_{z1} below 1/4 of the Fc to provides sufficient phase margin. C3 value is calculated by:

$$C3 \geq \frac{4}{2\pi \times F_C \times R2}$$

4. If the ESR output zero (f_{z2}) is located at less than one-half the switching frequency, use the (optional) secondary compensation capacitor (C6) to cancel it. As $f_{p3} = f_{z2}$, then:

$$C6 = \frac{C2 \times ESR}{R2}$$

** This specifications are subject to be changed without notice*

APPLICATION INFORMATION (continued)

Thermal Management

The ADT6780 contains an internal thermal sensor that limits the total power dissipation in the device and protects it in the event of an extended thermal fault condition. When the die temperature exceeds $+145^{\circ}\text{C}$ typically, the thermal sensor shuts down the device, turning off the DC-DC converter to allow the die to cool. After the die temperature falls by 10°C typically, the device automatically restarts, using the soft-start sequence.

The ADT6780 is available in a thermally enhanced SOP package and can dissipate up to 1.25W at $T_a=50^{\circ}\text{C}$ ($T_j=125^{\circ}\text{C}$). The exposed pad should be connected to GND externally, preferably soldered to a large ground plane to maximize thermal performance. Maximum available power dissipation should be de-rated by $17\text{mW}/^{\circ}\text{C}$ above $T_a=25^{\circ}\text{C}$ not to damage the device.

PCB Layout Consideration

PCB layout is very important to achieve clean and stable operation. It is highly recommended to follow below guidelines for good PCB layout.

1. Input capacitor (C1) should be placed as near as possible to the IC and connected with direct traces.
2. Keep the high current paths as short and wide as possible.
3. Keep the switching current path short and minimize the loop area, formed by SW, the output capacitors and the input capacitors.
4. Route high-speed switching nodes (such as SW and BST) away from sensitive analog areas (such as FB and COMP).
5. Ensure all feedback connections are short and direct. Place the current sense resistor and compensation components as close as possible to the IC.
6. Exposed pad of device must be connected to GND with solder. For single layer, do not solder exposed pad of the IC.

** This specifications are subject to be changed without notice*

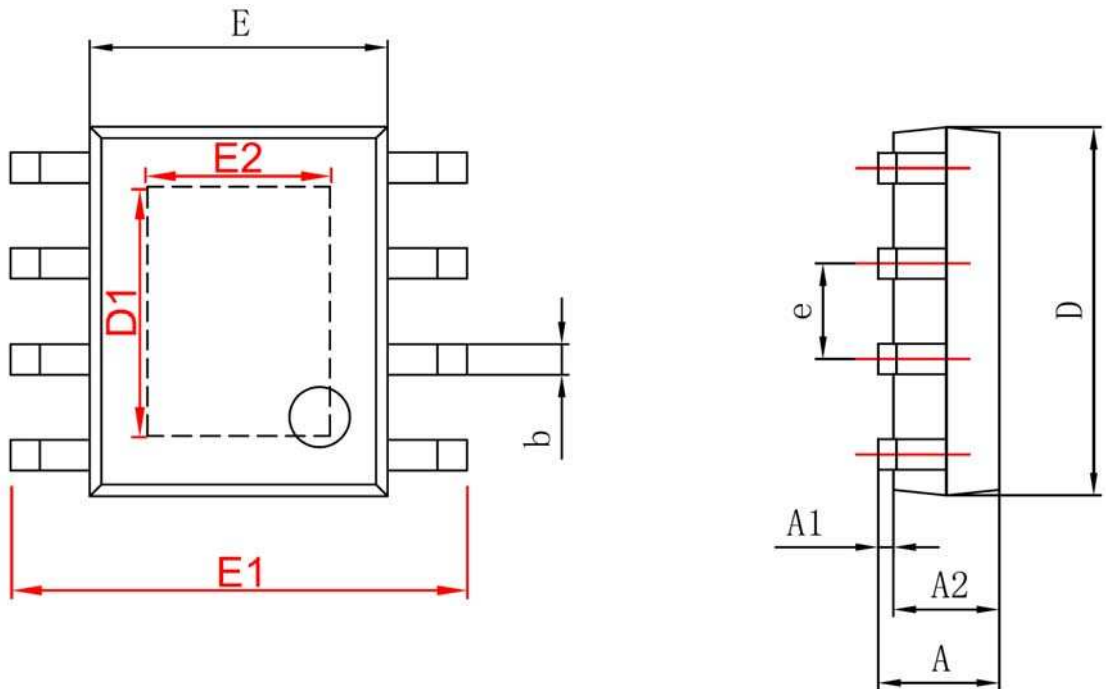
Package ; SOP8-PP(E-pad), 4.9mm x 3.94mm body (units : mm)

Symbol	Dimensions In Millimeters		Dimensions In Inches	
	Min	Max	Min	Max
A	1.350	1.750	0.053	0.069
A1	0.050	0.150	0.004	0.010
A2	1.350	1.550	0.053	0.061
b	0.330	0.510	0.013	0.020
c	0.170	0.250	0.006	0.010
D	4.700	5.100	0.185	0.200
D1	3.202	3.402	0.126	0.134
E	3.800	4.000	0.150	0.157
E1	5.800	6.200	0.228	0.244
E2	2.313	2.513	0.091	0.099
e	1.270 (BSC)		0.050 (BSC)	
L	0.400	1.270	0.016	0.050
θ	0°	8°	0°	8°

** This specifications are subject to be changed without notice*