

High-Temperature Silicon Carbide (SiC) Half-Bridge Power Module

N-Channel MOSFET Version

FEATURES

- Industry standard footprint
- High temperature: $T_{c(max)} = 225\text{ }^{\circ}\text{C}$
 $T_{j(max)} = 225\text{ }^{\circ}\text{C}$
- AS9100:Rev. C-certified manufacturing, traceable throughout value chain
- Ultra-fast switching (<30 ns), low inductance
- Enables high system efficiency
- Low profile, small form factor

1200 V / 3.6 mΩ

APPLICATIONS

- High-efficiency converters / inverters
- Motor drives
- Smart grid/grid-tie distributed generation
- Industrial and automotive traction drives

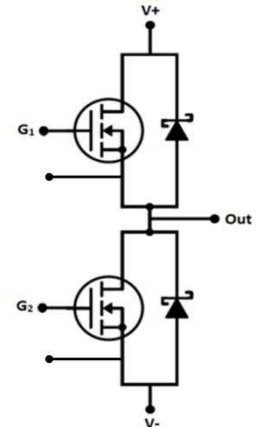

DESCRIPTION

The HT-3201 Silicon Carbide (SiC) half-bridge power module was designed specifically to address the growing demand for higher power densities, higher temperatures, and higher switching frequencies.

COMPANION PARTS

Maximum performance may be obtained through use of the companion high-temperature gate driver, part number MTGD2-3011, designed especially for driving the SiC module.

Power Module Absolute Maximum Ratings ($T_c = 25\text{ }^{\circ}\text{C}$ unless otherwise specified)

Symbol	Parameter	Condition(s)	Value	Units
V_{DSS}	Drain-source voltage		1200	V
V_{GSS}	Gate-source voltage		-10 to 25	V
I_D	Continuous drain current	$T_c = 25\text{ }^{\circ}\text{C}, T_j = 200\text{ }^{\circ}\text{C}$	433	A
		$T_c = 175\text{ }^{\circ}\text{C}, T_j = 200\text{ }^{\circ}\text{C}$	170	
I_{DM}	Peak pulsed drain current	Pulse width $\leq 10\text{ }\mu\text{s}$, duty cycle $\leq 2\%$	TBD	A
P_D	Maximum power dissipated	$T_j = 225\text{ }^{\circ}\text{C}$	2000	W
$T_{C(max)}$	Maximum case temperature ¹		225	$^{\circ}\text{C}$
$T_{J(min)}$	Minimum operating junction temperature		- 50	$^{\circ}\text{C}$
$T_{J(max)}$	Maximum operating junction temperature		225	
T_{stg}	Storage temperature		- 50 to 225	$^{\circ}\text{C}$
V_{isol}	Insulation test voltage	AC, 1 min.	TBD	V
		AC, 1 s.	TBD	

¹The packaging materials have been qualified at this temperature.

Switch Position Electrical Characteristics (T_C = 25 °C unless otherwise specified)						
Symbols	Parameter	Condition(s)	Values			Units
			Min.	Typical	Max.	
V _{(BR)DSS}	Drain-source breakdown voltage	V _{GS} = 0 V, I _D = 1 mA	1200	-	-	V
V _{GS(th)}	Gate-source threshold voltage	V _{DS} = 10 V, I _D = 1 mA	-	5.25	-	V
		V _{DS} = 10 V, I _D = 1 mA, T _J = 200 °C	-	4.5	-	
I _{DSS}	Drain-source leakage current	V _{GS} = - 5 V, V _{DS} = 1200 V	-	720	-	μA
		V _{GS} = - 5 V, V _{DS} = 1200 V, T _J = 200 °C	-	-	-	
I _{GSS}	Gate-source leakage current	V _{GS} = 20 V, V _{DS} = 0 V	-	-	3.5	μA
R _{DS(on)}	Drain-source turn-on resistance	V _{GS} = 20 V, I _D = 400 A	-	3.6	-	mΩ
		V _{GS} = 20 V, I _D = 400 A, T _J = 200 °C	-	9.4	-	
C _{iss}	Input capacitance	V _{GS} = 0 V, V _{DS} = 1000 V	-	20,860	-	pF
C _{oss}	Output capacitance	f = 1 MHz, V _{AC} = 25 mV	-	1,540	-	
C _{rss}	Reverse transfer capacitance	MOSFETs only	-	161	-	
t _{d(on)}	Turn-on delay time	V _{DD} = 600 V, V _{GS} = - 4 to 20 V I _D = 120 A R _{G(ext)} = 0 Ω, R _L = 60 Ω	-	-	-	ns
t _{rv}	Rise time		-	50	-	
t _{d(off)}	Turn-off delay time		-	-	-	
t _{fv}	Fall time		-	70	-	

Switch Position Gate Charge Electrical Characteristics (T_C = 25 °C unless otherwise specified)						
Symbols	Parameter	Condition(s)	Values			Units
			Min.	Typical	Max.	
Q _{gs}	Gate to source charge	V _{DD} = 800 V, V _{GS} = 0/20 V I _D = 140 A	-	224	-	nC
Q _{gd}	Gate to drain charge		-	441	-	
Q _g	Gate charge total		-	1,253	-	

Diode Position Electrical Characteristics (T_C = 25 °C unless otherwise specified)						
Symbols	Parameter	Condition(s)	Values			Units
			Min.	Typical	Max.	
V _{FM}	Forward voltage	I _F = 350 A	1.6	1.8	-	V
		I _F = 350 A, T _J = 200 °C	2.05	2.3	-	
I _R	Reverse current	V _R = 1200 V	-	700	-	μA
		V _R = 1200 V, T _J = 200 °C	-	TBD	-	
Q _C	Capacitive charge	V _R = 400 V	1,020	-	-	nC

Thermal Characteristics (T_J = 25 °C unless otherwise specified)						
Symbols	Parameter	Condition(s)	Values			Units
			Min.	Typical	Max.	
R _{θ(j-c)}	MOSFET thermal resistance junction-case		0.085	0.1	-	°C/W

Power Module Mechanical Characteristics						
Symbols	Parameter	Condition(s)	Values			Units
			Min.	Typical	Max.	
w	Weight		-	140	-	g
M _s	Lead frame mounting torque	M4 bolts	-	1.13	-	N·m

TYPICAL PERFORMANCE CURVES

 Fig. 1. Output characteristics at $V_{gs} = 20$ V at 25 °C & 200 °C.

 Fig. 2. On-resistance at $V_{gs} = 20$ V at 25 °C & 200 °C.

 Fig. 3. Transconductance with $V_{ds} = 20$ V at 25 °C & 200 °C.

Fig. 4. Reverse diode characteristics at 25 °C & 200 °C.

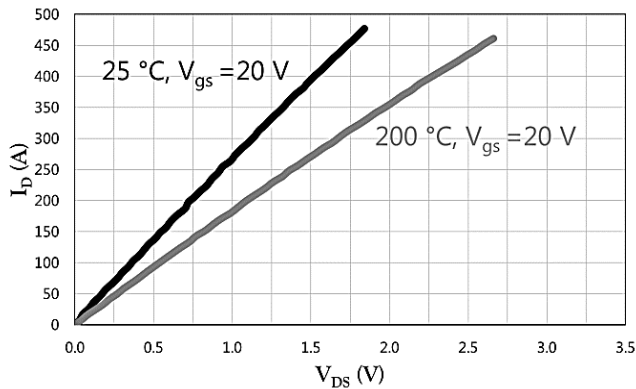
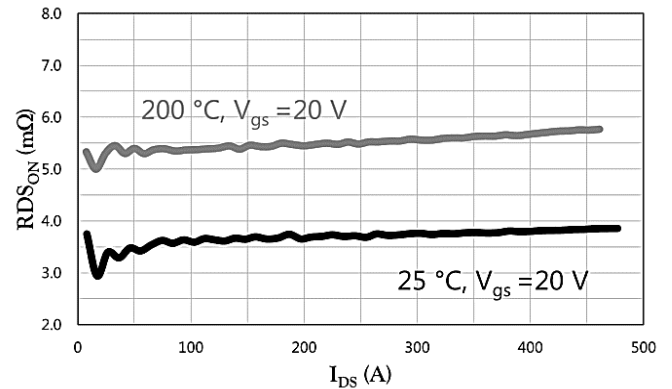
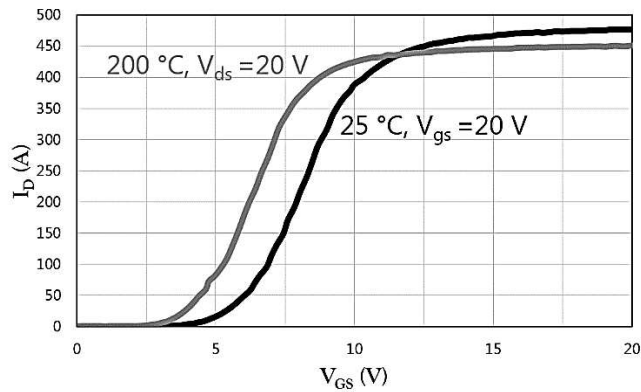
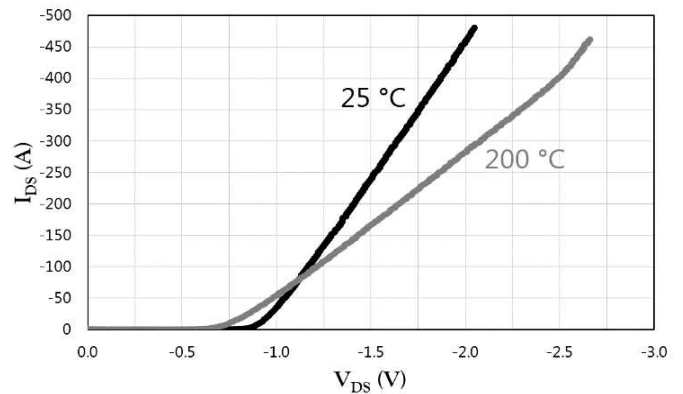
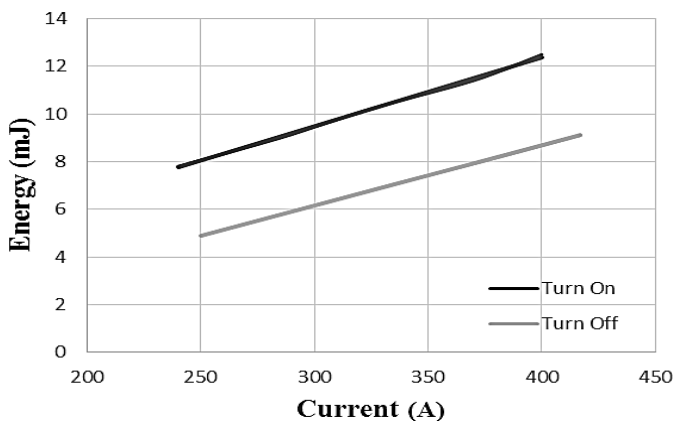
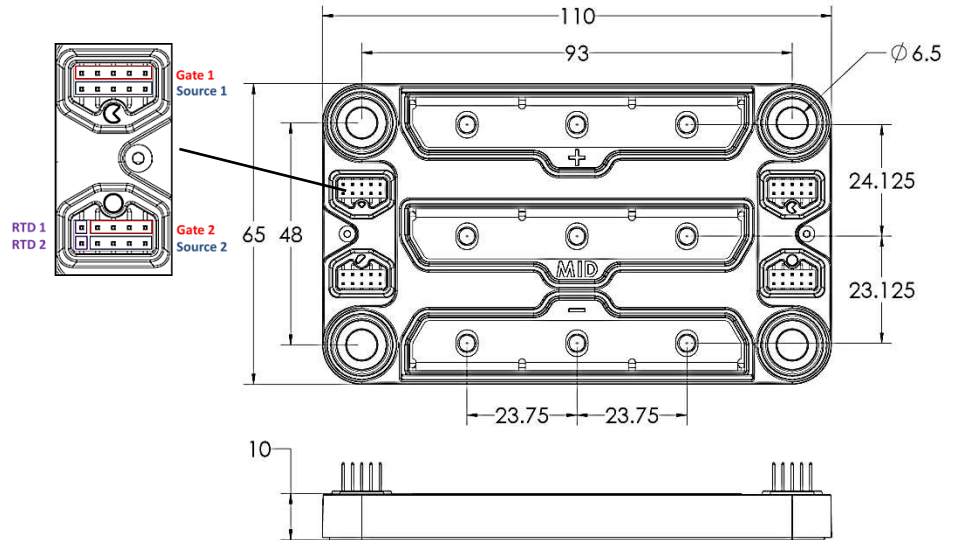

 Fig. 5. Switching Energy with $R_g = 5$ Ω & $V_{bus} = 600$ V

DIMENSIONS

All dimensions are listed in millimeters.

Bolts - Lead frame: M4
Base plate: M6

CAD models are available upon request.

ORDERING INSTRUCTIONS

An order for one or more parts can be initiated by issuing a purchase order to APEI. Please e-mail or fax your purchase order to sales@apei.net or +1.866.515.6604, respectively.

APEI
535 W. Research Center Blvd.
Fayetteville, AR 72701
Phone: 479.443.5759 | Fax: 866.515.6604
www.apei.net

DISCLAIMER

ALL PRODUCT, PRODUCT SPECIFICATIONS AND DATA ARE SUBJECT TO CHANGE WITHOUT NOTICE TO IMPROVE RELIABILITY, FUNCTION, DESIGN OR OTHERWISE.

Arkansas Power Electronics International, Inc., its affiliates, agents, and employees, and all persons acting on its or their behalf (collectively, "APEI"), disclaim any and all liability for any errors, inaccuracies or incompleteness contained in any datasheet or in any other disclosure relating to any product.

All product data sheets, product manuals and any other product related documentation, and all APEI products, courtesy samples and services are subject to APEI's Standard Terms and Conditions available online at <http://www.apei.net/termsandconditions.pdf>.

ALL APEI PRODUCTS, PROTOTYPES AND ANY OTHER DEVICES MADE BY APEI SHALL BE TREATED AS ENGINEERING SAMPLES AND AS SUCH APEI DOES NOT ACCEPT ANY PRODUCT LIABILITY, CLAIMS OR DAMAGES OR FUTURE OBLIGATIONS TO SUPPLY. THE CONTENTS DISCLOSED IN ANY DATASHEET AND ALL OF APEI'S PRODUCTS, PROTOTYPES AND OTHER DEVICES SOLD OR PROVIDED BY APEI ARE "AS-IS" WITH NO WARRANTY OF ANY KIND, EITHER EXPRESS OR IMPLIED. APEI DOES NOT WARRANT THAT ITS ENGINEERING SAMPLES ARE FULLY VERIFIED, TESTED, OR WILL OPERATE IN ACCORDANCE WITH ANY DATA SHEET SPECIFICATIONS. APEI DISCLAIMS ANY OBLIGATIONS FOR TECHNICAL SUPPORT AND BUG FIXES. APEI SHALL NOT BE LIABLE FOR ANY DAMAGES, INCLUDING WITHOUT LIMITATION DIRECT, INDIRECT, INCIDENTAL, SPECIAL, RELIANCE, PUNITIVE, STATUTORY OR CONSEQUENTIAL DAMAGES ARISING FROM OR IN CONNECTION WITH THE CONTENTS OF ANY PRODUCT DATASHEET OR THE USE, INSTALLATION, OR IMPLEMENTATION OF ENGINEERING SAMPLES IN ANY MANNER WHATSOEVER, EVEN IF SELLER HAS BEEN ADVISED OF THE POSSIBILITY THEREOF. APEI MAKES NO REPRESENTATION THAT ITS ENGINEERING SAMPLES PROVIDE ANY PARTICULAR FUNCTIONALITY, OR THAT ITS ENGINEERING SAMPLES WILL MEET THE REQUIREMENTS OF A PARTICULAR USER APPLICATION. APEI DOES NOT WARRANT THAT ITS ENGINEERING SAMPLES ARE ERROR-FREE, NOR DOES APEI MAKE ANY OTHER REPRESENTATIONS OR WARRANTIES, WHETHER EXPRESS OR IMPLIED, STATUTORY OR OTHERWISE, INCLUDING WITHOUT LIMITATION, IMPLIED WARRANTIES OF MERCHANTABILITY, FITNESS FOR A PARTICULAR PURPOSE, OR NON-INFRINGEMENT.

APEI'S PRODUCTS AND PROTOTYPES ARE ENGINEERING SAMPLES AND ARE NOT DESIGNED OR INTENDED TO BE FAIL-SAFE, FAULT TOLERANT OR FOR USE IN ANY APPLICATION THAT COULD LEAD TO DEATH, PERSONAL INJURY OR SEVERE PROPERTY OR ENVIRONMENTAL DAMAGE (INDIVIDUALLY AND COLLECTIVELY, "CRITICAL APPLICATIONS"), SUCH AS LIFE-SUPPORT OR SAFETY DEVICES OR SYSTEMS, CLASS III MEDICAL DEVICES, NUCLEAR FACILITIES, APPLICATIONS THAT AFFECT CONTROL OF A VEHICLE OR AIRCRAFT, APPLICATIONS RELATED TO THE DEPLOYMENT OF AIRBAGS, OR ANY OTHER CRITICAL APPLICATIONS. APEI SHALL NOT BE LIABLE FOR ANY DAMAGES, INCLUDING WITHOUT LIMITATION DIRECT, INDIRECT, INCIDENTAL, SPECIAL, RELIANCE, PUNITIVE OR CONSEQUENTIAL DAMAGES IN ANY MANNER WHATSOEVER, ARISING FROM OR IN CONNECTION WITH THE USE OF ITS PRODUCTS, SAMPLES OR PROTOTYPES IN CRITICAL APPLICATIONS, EVEN IF APEI HAS BEEN ADVISED OF THE POSSIBILITY THEREOF.

No license, express or implied, by estoppel or otherwise, to any intellectual property rights is granted by this document or by any conduct of APEI.

Copyright © 2014 APEI. All rights reserved.