

High Temperature Silicon Carbide Power MOSFET

N-Channel Enhancement Mode

1200 V / 50 A / 80 mΩ

FEATURES

- High temperature: $T_{C(max)} = 225\text{ °C}$, $T_{J(max)} = 225\text{ °C}$
- AS9100:Rev. C-certified manufacturing, traceable throughout value chain
- < 20 ns switching, enables high system efficiency
- Hermetic seal; flux-free packaging; high reliability
- Backside isolation

HIGH TEMPERATURE APPLICATIONS

- Downhole tools
- High efficiency DC/DC converters & motor drives
- Aerospace: Military & Commercial
- Smart grid/grid-tie distributed generation
-

COMPANION PARTS

- Silicon Carbide Schottky Diodes, APE HT-0122, APE HT-0123
- Low-Temperature Single-Channel Gate Driver, APE ITGD1-0021
- Mil-Temperature Dual-Channel Gate Driver, APE MTGD2-2011
- High-Temperature Dual-Channel Gate Driver, APE HTGD2-0031

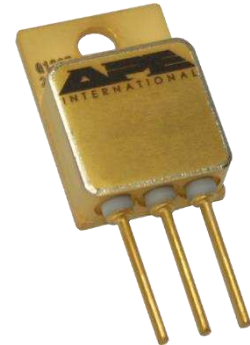
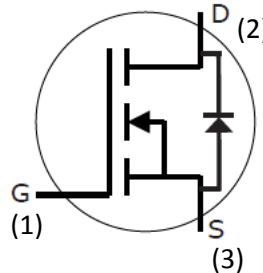

TO-254 Package 1 2 3
G D S

Absolute Maximum Ratings¹ ($T_J = 25\text{ °C}$ unless otherwise specified)

Symbol	Parameter	Condition(s)	Value	Units
V_{DSS}	Drain-source voltage		1200	V
V_{GSS}	Gate-source voltage		-5 to 25	V
I_D	Continuous drain current ²	$V_{GS} = 20\text{ V}$, $T_C = 25\text{ °C}$	50	A
		$V_{GS} = 20\text{ V}$, $T_C = 100\text{ °C}$	40 ³	
		$V_{GS} = 20\text{ V}$, $T_C = 200\text{ °C}$	18 ³	
I_{DM}	Peak pulsed drain current ¹	Pulse width t_p limited by $T_{J(max)}$; $T_J = 25\text{ °C}$, $t_p = 1\text{ ms}$	90	A
E_{AS}	Single-pulse avalanche energy	$I_D = 20\text{ A}$, $V_{DD} = 50\text{ V}$, $L = 9.5\text{ mH}$	2.2	J
E_{AR}	Repetitive avalanche energy	t_{AR} limited by $T_{J(max)}$	1.5	J
I_{AR}	Repetitive avalanche current	$I_D = 20\text{ A}$, $V_{DD} = 50\text{ V}$, $L = 3\text{ mH}$; t_{AR} limited by $T_{J(max)}$	20	A
P_{tot}	Power dissipation ¹	$T_C = 25\text{ °C}$	200 ³	W
		$T_C = 100\text{ °C}$	125 ³	
		$T_C = 200\text{ °C}$	25 ³	
T_J	Operating junction temperature		-50 to 225 ³	°C
T_{stg}	Storage temperature		-50 to 225 ³	°C
V_{isol}	Insulation test voltage	AC, 1 min.	TBD	V
		AC, 1 s.	TBD	V

¹ Obtained from Cree Inc. CPMF-1200-S080B Rev. A datasheet

² Assumes a thermal resistance junction to case of $\leq 1.0\text{ °C/W}$

³ Data obtained through APEI experimentation and/or calculation

SiC MOSFET Electrical Characteristics¹ (T_J = 25 °C unless otherwise specified)							
Symbols	Parameter	Condition(s)	Values			Units	
			Min.	Typical	Max.		
V _{(BR)DSS}	Drain-source breakdown voltage	V _{GS} = 0 V, I _D = 100 μA	1200	-	-	V	
V _{GS(th)}	Gate-source threshold voltage ⁴	V _{DS} = V _{GS} , I _D = 1 mA	-	2.5	-	V	
		V _{DS} = V _{GS} , I _D = 1 mA, T _J = 225 °C ³	-	1.6	-		
I _{DSS}	Zero gate voltage drain current	V _{DS} = 1200 V, V _{GS} = 0 V	-	1	100	μA	
		V _{DS} = 1200 V, V _{GS} = 0 V, T _J = 225 °C ³	-	-	2000		
I _{GSS}	Gate-source leakage current	V _{GS} = 20 V, V _{DS} = 0 V	-	-	250	nA	
R _{DS(on)}	Drain-source on-resistance	V _{GS} = 20 V, I _D = 20 A	-	80	110	mΩ	
		V _{GS} = 20 V, I _D = 20 A, T _J = 225 °C ³	-	190	260		
g _{fs}	Transconductance	V _{GS} = 20 V, I _D = 20 A	-	7.3	-	S	
		V _{GS} = 20 V, I _D = 20 A, T _J = 225 °C ³	-	TBD	-		
C _{iss}	Input capacitance	V _{GS} = 0 V	-	1915	-	pF	
C _{oss}	Output capacitance	V _{DS} = 800 V	-	120	-	pF	
C _{rss}	Reverse transfer capacitance	f = 1 MHz V _{AC} = 25 mV	-	13	-	pF	
t _{d(on)}	Turn-on delay time	V _{DD} = 800 V, V _{GS} = -2 to 20 V I _D = 20 A R _{G(ext)} = 6.8 Ω, L = 856 μH Per JEDEC24 p. 27	-	17.2	-	ns	
t _{rv}	Rise time		-	13.6	-	ns	
t _{d(off)}	Turn-off delay time		-	62	-	ns	
t _{fv}	Fall time		-	35.6	-	ns	
E _{on}	Turn-On switching loss		-	-	530	-	μJ
			-	-	410 ⁵	-	
E _{off}	Turn-Off switching loss		-	-	320	-	μJ
		-	-	345 ⁵	-		
R _G	Internal gate resistance	V _{GS} = 0 V, f = 1 MHz, V _{AC} = 25 mV	-	5	-	Ω	

SiC Inverse Body Diode Electrical Characteristics^{1,6} (T_J = 25 °C unless otherwise specified)						
Symbols	Parameter	Condition(s)	Values			Units
			Min.	Typical	Max.	
V _{SD}	Diode forward voltage	V _{GS} = -5 V, I _F = 10 A	-	3.5	-	V
		V _{GS} = -2 V, I _F = 10 A	-	3.1	-	
t _{rr}	Reverse recovery time	V _{GS} = -5 V, I _F = 20 A	-	220	-	ns
Q _{rr}	Reverse recovery charge	V _R = 800 V	-	142	-	nC
I _{rrm}	Peak reverse recovery current	di _F /dt = 100 A/μs	-	2.3	-	A

⁴ The recommended on-state V_{GS} is +20 V and the recommended off-state V_{GS} is between 0 V and -5 V

⁵ 150 °C

⁶ APEI recognizes the end user's ultimate responsibility for determining the appropriateness of use and effectiveness of the SiC inverse body diode for freewheeling capability in their specific application. APEI recommends that the end user bypass the SiC inverse body diode during operation. Increased performance may be achieved by using other APEI products found in the Companion Parts section of this datasheet.

SiC MOSFET Gate Charge Electrical Characteristics ¹ ($T_J = 25\text{ }^\circ\text{C}$ unless otherwise specified)						
Symbols	Parameter	Condition(s)	Values			Units
			Min.	Typical	Max.	
Q_{gs}	Gate to source charge	$V_{DD} = 800\text{ V}$, $V_{GS} = 0$ to 20 V	-	23.8	-	nC
Q_{gd}	Gate to drain charge	$I_D = 20\text{ A}$	-	43.1	-	nC
Q_g	Gate charge total	Per JEDEC24, p. 27	-	90.8	-	nC

Thermal Characteristics ($T_J = 25\text{ }^\circ\text{C}$ unless otherwise specified)						
Symbols	Parameter	Condition(s)	Values			Units
			Min.	Typical	Max.	
$R_{\theta(J-C)}$	Thermal resistance junction-case	Calculated at $200\text{ }^\circ\text{C}$	-	TBD	1.0	$^\circ\text{C/W}$

Mechanical Characteristics ($T_J = 25\text{ }^\circ\text{C}$ unless otherwise specified)						
Symbols	Parameter	Condition(s)	Values			Units
			Min.	Typical	Max.	
w	Weight		-	9.0	-	g
M_s	Mounting torque	6-32 steel screw, Al heat sink	-	0.78	1.04	N-m

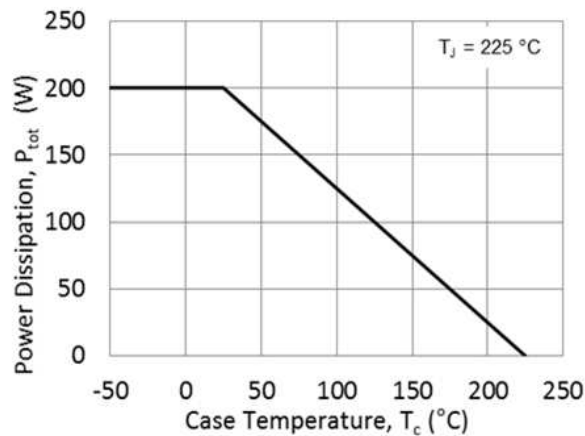
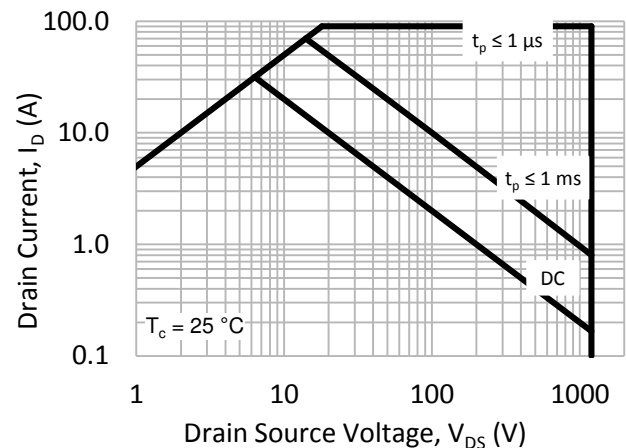
TYPICAL PERFORMANCE CURVES

 Fig. 1 - Maximum power dissipation P_{tot} versus case temperature T_c

 Fig. 2 - Maximum safe operating area (SOA) $I_D = f(V_{DS})$

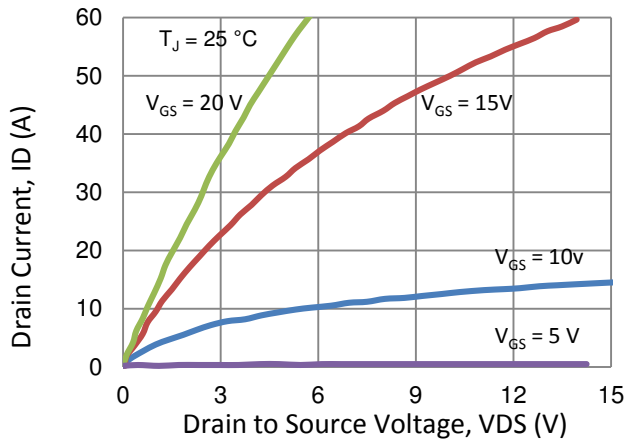
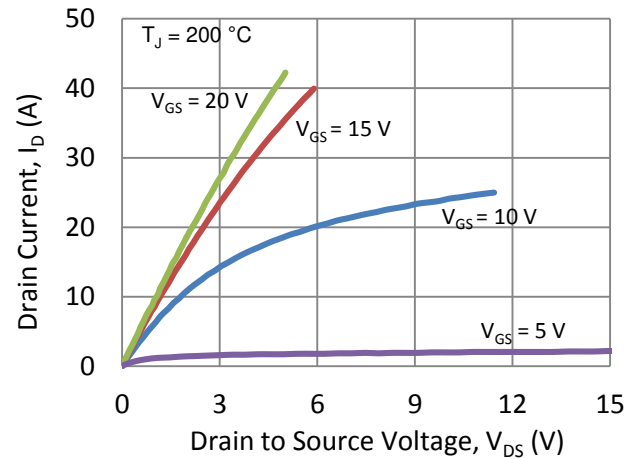
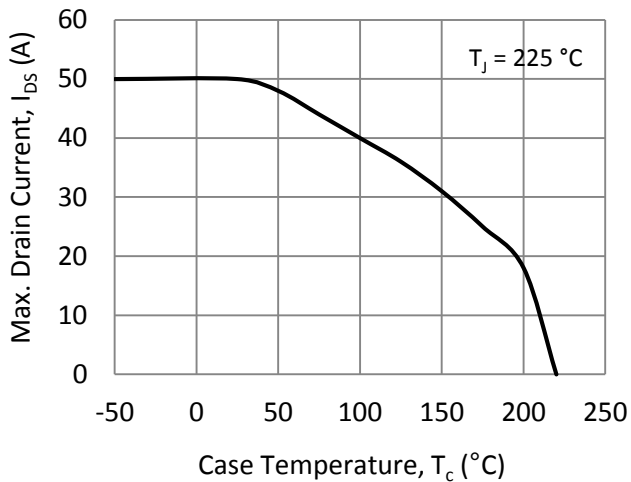
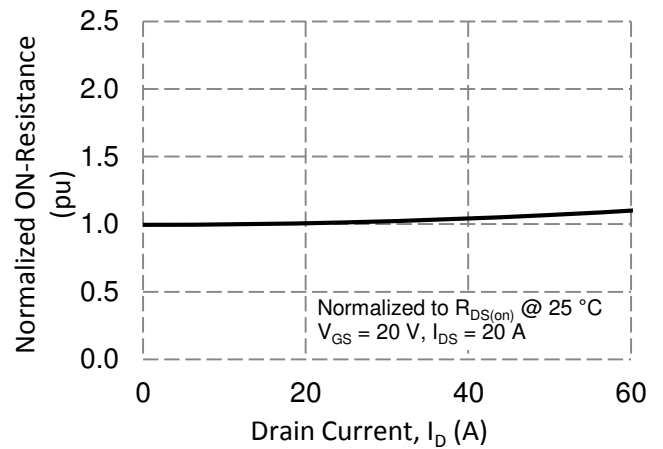

 Fig. 3 - Forward output characteristic $I_D = f(V_{DS})$, $25\text{ }^\circ\text{C}$

 Fig. 4 - Forward output characteristic $I_D = f(V_{DS})$, $200\text{ }^\circ\text{C}$

 Fig. 5 - Drain current derating versus case temperature T_C

Fig. 6 - ON-resistance versus drain current and gate-source voltage

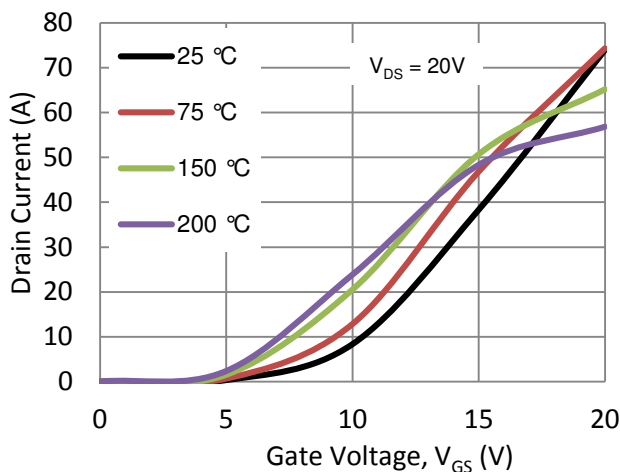
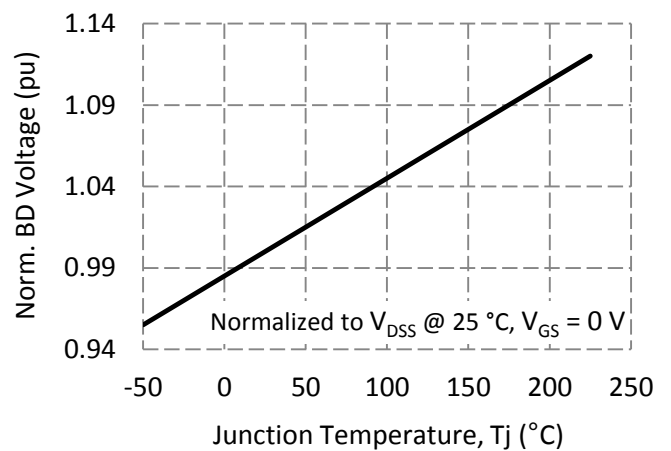
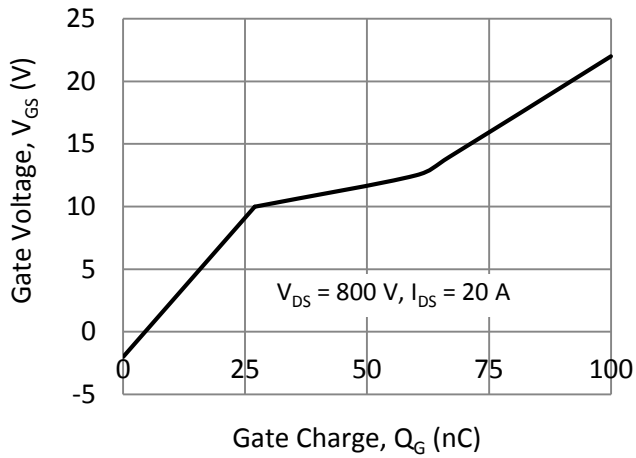
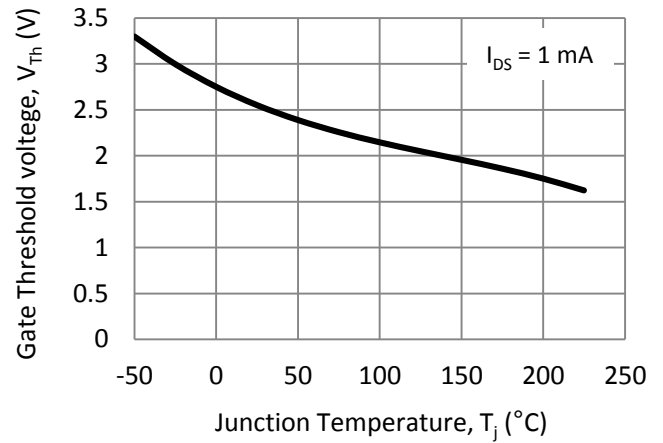
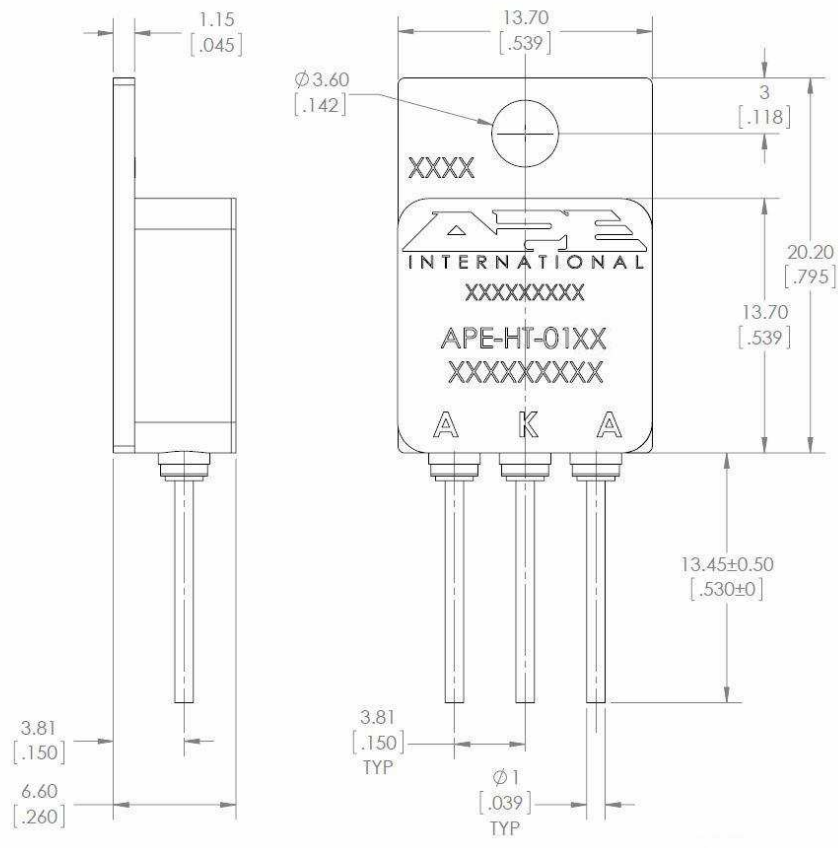

Fig. 7 - Transconductance versus temperature

 Fig. 8 - Drain-source breakdown voltage versus junction temperature T_J

 Fig. 9 - Gate charge characteristic $V_{GS} = f(Q_G)$

 Fig. 10 - Gate-source threshold voltage versus junction temperature T_J
PACKAGE DIMENSIONS

All dimensions shown are in inches [millimeters]



PART NUMBER	PACKAGE	MARKING
APE HT-0121	TO-254	Q120709001



PRELIMINARY

APE HT-0121

DISCLAIMER

ALL PRODUCT, PRODUCT SPECIFICATIONS AND DATA ARE SUBJECT TO CHANGE WITHOUT NOTICE TO IMPROVE RELIABILITY, FUNCTION, DESIGN OR OTHERWISE.

Arkansas Power Electronics International, Inc., its affiliates, agents, and employees, and all persons acting on its or their behalf (collectively, "APEI"), disclaim any and all liability for any errors, inaccuracies or incompleteness contained in any datasheet or in any other disclosure relating to any product.

All product data sheets, product manuals and any other product related documentation, and all APEI products, courtesy samples and services are subject to APEI's Standard Terms and Conditions available online at <http://www.apei.net/termsandconditions.pdf>.

ALL APEI PRODUCTS, PROTOTYPES AND ANY OTHER DEVICES MADE BY APEI SHALL BE TREATED AS ENGINEERING SAMPLES AND AS SUCH APEI DOES NOT ACCEPT ANY PRODUCT LIABILITY, CLAIMS OR DAMAGES OR FUTURE OBLIGATIONS TO SUPPLY. THE CONTENTS DISCLOSED IN ANY DATASHEET AND ALL OF APEI'S PRODUCTS, PROTOTYPES AND OTHER DEVICES SOLD OR PROVIDED BY APEI ARE "AS-IS" WITH NO WARRANTY OF ANY KIND, EITHER EXPRESS OR IMPLIED. APEI DOES NOT WARRANT THAT ITS ENGINEERING SAMPLES ARE FULLY VERIFIED, TESTED, OR WILL OPERATE IN ACCORDANCE WITH ANY DATA SHEET SPECIFICATIONS. APEI DISCLAIMS ANY OBLIGATIONS FOR TECHNICAL SUPPORT AND BUG FIXES. APEI SHALL NOT BE LIABLE FOR ANY DAMAGES, INCLUDING WITHOUT LIMITATION DIRECT, INDIRECT, INCIDENTAL, SPECIAL, RELIANCE, PUNITIVE, STATUTORY OR CONSEQUENTIAL DAMAGES ARISING FROM OR IN CONNECTION WITH THE CONTENTS OF ANY PRODUCT DATASHEET OR THE USE, INSTALLATION, OR IMPLEMENTATION OF ENGINEERING SAMPLES IN ANY MANNER WHATSOEVER, EVEN IF SELLER HAS BEEN ADVISED OF THE POSSIBILITY THEREOF. APEI MAKES NO REPRESENTATION THAT ITS ENGINEERING SAMPLES PROVIDE ANY PARTICULAR FUNCTIONALITY, OR THAT ITS ENGINEERING SAMPLES WILL MEET THE REQUIREMENTS OF A PARTICULAR USER APPLICATION. APEI DOES NOT WARRANT THAT ITS ENGINEERING SAMPLES ARE ERROR-FREE, NOR DOES APEI MAKE ANY OTHER REPRESENTATIONS OR WARRANTIES, WHETHER EXPRESS OR IMPLIED, STATUTORY OR OTHERWISE, INCLUDING WITHOUT LIMITATION, IMPLIED WARRANTIES OF MERCHANTABILITY, FITNESS FOR A PARTICULAR PURPOSE, OR NON-INFRINGEMENT.

APEI'S PRODUCTS AND PROTOTYPES ARE ENGINEERING SAMPLES AND ARE NOT DESIGNED OR INTENDED TO BE FAIL-SAFE, FAULT TOLERANT OR FOR USE IN ANY APPLICATION THAT COULD LEAD TO DEATH, PERSONAL INJURY OR SEVERE PROPERTY OR ENVIRONMENTAL DAMAGE (INDIVIDUALLY AND COLLECTIVELY, "CRITICAL APPLICATIONS"), SUCH AS LIFE-SUPPORT OR SAFETY DEVICES OR SYSTEMS, CLASS III MEDICAL DEVICES, NUCLEAR FACILITIES, APPLICATIONS THAT AFFECT CONTROL OF A VEHICLE OR AIRCRAFT, APPLICATIONS RELATED TO THE DEPLOYMENT OF AIRBAGS, OR ANY OTHER CRITICAL APPLICATIONS. APEI SHALL NOT BE LIABLE FOR ANY DAMAGES, INCLUDING WITHOUT LIMITATION DIRECT, INDIRECT, INCIDENTAL, SPECIAL, RELIANCE, PUNITIVE OR CONSEQUENTIAL DAMAGES IN ANY MANNER WHATSOEVER, ARISING FROM OR IN CONNECTION WITH THE USE OF ITS PRODUCTS, SAMPLES OR PROTOTYPES IN CRITICAL APPLICATIONS, EVEN IF APEI HAS BEEN ADVISED OF THE POSSIBILITY THEREOF.

No license, express or implied, by estoppel or otherwise, to any intellectual property rights is granted by this document or by any conduct of APEI.

ORDERING INSTRUCTIONS

An order for one or more parts can be initiated by issuing a purchase order to APEI, Inc. Please e-mail or fax your purchase order to sales@apei.net or +1.866.515.6604, respectively.

APEI, Inc.
535 W. Research Center Blvd.
Fayetteville, AR 72701
Phone: 479.443.5759 / Fax: 866.515.6604
www.apei.net

Copyright © 2013 APEI, Inc.
All rights reserved.