

Part Number: T5297ST - Dual Output 5Vdc 2A Car USB Adaptor

Product Image

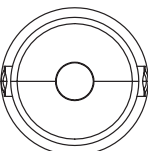

Mechanical Drawings (mm)

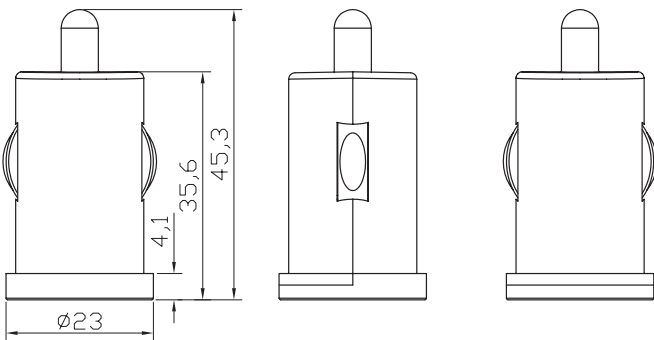
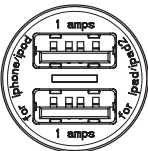

Input

Input Voltage 12Vdc (Nominal)
 Input Current <30mA (No Load)
 Power Inlet Cigarette Lighter Style

Output

Output Voltage 5Vdc
 Total Output Current 2Amp
 Output Current Per Port 1Amp
 Load Power 10Watts
 USB Output Dual Port 13x5mm USB socket

Safety & Other

Protections Overload (Current / Power) protection
 Short circuit protection

Operating Temp 0 to 25°C
 Storage Temp -20 to 60°C
 Operating Humidity 20% to 90%
 Storage Humidity 0% to 100%

MTBF 50000 Hrs Min.

CE Compliant
 RoHS Compliant

Disclaimer

Stontronics Ltd accepts no responsibility for typographical errors in the production of this leaflet. Product specifications are subject to change without notice.

Stontronics Ltd is ISO 9001:2008 registered.



For more information please contact us:

Stontronics Ltd,
 Chancerygate Business Centre, Cradock Road, Reading, Berkshire, RG2 0AH
 Tel: 0118 931 1199
 Fax: 0118 931 1145
 Email: info@stontronics.co.uk • www.stontronics.co.uk