

## Part Number: T3299EG - 12VDC 12 Watt Euro Flanged SMPSU

### Product Image

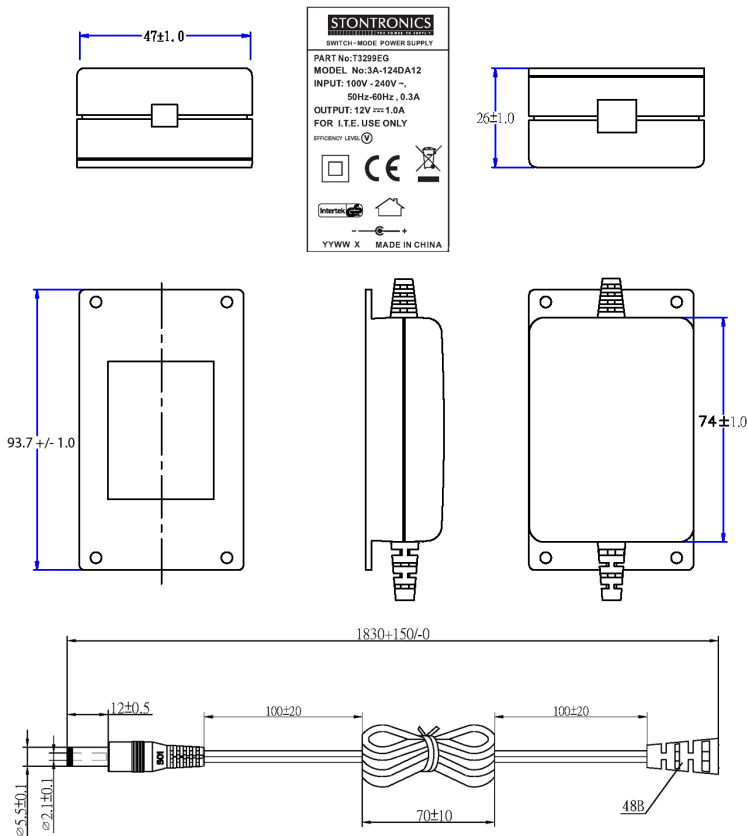

### Mechanical Drawings (mm)



### Input

Input Voltage Range ..... 90 - 264 VAC  
 Input Frequency ..... 47 - 63 Hz  
 Input Current ..... 300mA RMS Max  
 Leakage Current ..... 0.25mA  
 Input Power (with no load)..... <0.3W  
 AC Receptacle ..... Standard Euro Plug

### Output

Output Voltage ..... +12VDC  
 Minimum Load Current ..... 0Amp  
 Nominal Load Current ..... 1Amp  
 Nominal Load Power ..... 12Watts  
 Load Regulation ..... +/- 5 %  
 Over Voltage Protection ..... Clamped by Internal protection Zener  
 Short circuit protection ..... Output shut down and auto restart  
 Ripple And Noise ..... 150 mV p-p Maximum  
 Efficiency ..... 77.7% min.  
 EuP Level ..... Meets Level V

### Other

Dimensions ..... 75 (L) \* 47.5 (W) \* 26.5 (H) mm Max.  
 Operating Temperature ..... 0 °C To 40 °C  
 Operating Humidity ..... 20 ~ 80 % Rh. Non-Condensing  
 Storage Temperature ..... -10 °C To 70 °C  
 Storage Humidity ..... 10 ~ 90 % Rh. Non-Condensing

### Safety

**Emi Standards**  
 Meets FCC class B, CE, VCCI  
**Safety Standards**  
 Safety approved to: GS & CE  
 RoHS Compliant  
 Hi-Pot & Insulation resistance tested

### Disclaimer

Stontronics Ltd accepts no responsibility for typographical errors in the production of this leaflet. Product specifications are subject to change without notice.

Stontronics Ltd is ISO 9001:2008 registered.



### You might also be interested in...

Our range of cost effective and reliable EU Plugtops - available from stock or customised with a bespoke design tailored to your application. Click here now for more details.



For more information please contact us:  
 Stontronics Ltd,

Chancerygate Business Centre, Cradock Road, Reading, Berkshire, RG2 0AH  
 Tel: 0118 931 1199  
 Fax: 0118 931 1145

Email: info@stontronics.co.uk  
[www.stontronics.co.uk](http://www.stontronics.co.uk)