

STONTRONICS

THE POWER TO SUPPLY

CHANCERYGATE BUSINESS CENTRE, CRADOCK ROAD, READING, RG2 0AH
 TEL: 0118 931 1199 FAX: 0118 931 1145
 INFO@STONTRONICS.CO.UK WWW.STONTRONICS.CO.UK

Stontronics Ltd Product Data Sheet

Part Number: **T4845ST - 12Vdc 10A C14 Desktop SMPSU**

Product Image



Level **V** Compliant



Mechanical Drawings (mm)

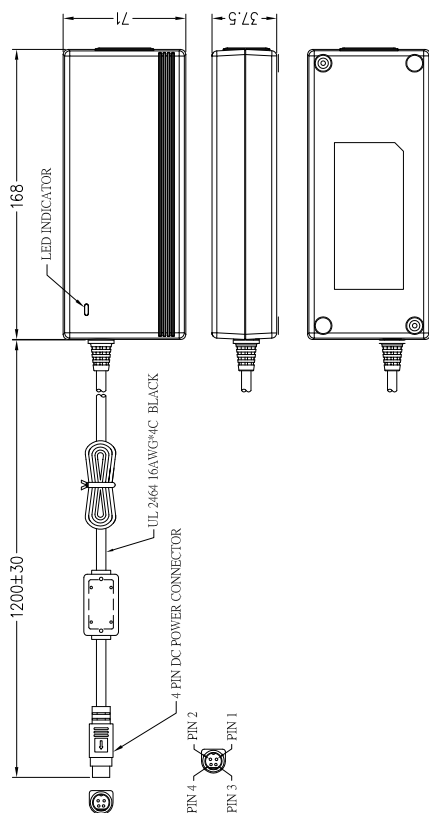

Disclaimer

Stontronics Ltd accepts no responsibility for typographical errors in the production of this leaflet. Product specifications are subject to change without notice.

For more information please contact us:
 Stontronics Ltd,
 Chancerygate Business Centre, Cradock Road, Reading, Berkshire, RG2 0AH
 Tel: 0118 931 1199
 Fax: 0118 931 1145
 Email: info@stontronics.co.uk • www.stontronics.co.uk

Input

Rated Input Voltage 100 - 240VAC
 Input Voltage Range 90 - 264VAC
 Frequency Range 47 - 63 Hz
 Rated Input Current 2A RMS Max.
 Inrush Current 150A Max @ 240VAC
 Current Protection Fuse 3.15A 250V Time Lag Fuse
 Standby Power (no load) <0.5W
 Efficiency 87% min. Average
 EuP / ErP compliant Yes. Level V Compliant

Output

Output Voltage +12VDC (+/- 5%)
 Minimum Load Current 0Amp
 Nominal Load Current 10A
 Nominal Load Power 120Watts
 Short circuit protection No damage from short conditions
 Over Voltage protection ... Max OVP Trip Voltage +16V - PSU will shut down & mains should be removed.
 Over Power Protection Protection shall operate between 130~200% of rated power
 Ripple Voltage 120mV (P-P) (@ full load)
 Output Connection Style 4-Pin Mini DIN - 1 & 2 +V, 3 & 4 GND

Other

Turn on Delay Time Output steady by 3 seconds
 Hold Up Time 8ms @ 45°C
 Operation Vibration 10-250Hz, 0.25G p-p, 3 axes, 15min sweep
 Altitude PSU will operate up to 10,000 feet
 Operating Temperature 0 °C To +40 °C
 Storage Temperature -20 °C To +80 °C
 Operating Humidity 10% to 90%
 Storage Humidity 5% to 95%
 MTBF.....<50,000 hours

Safety

Leakage Current 3.5mA Max. @ 264VAC 60Hz
 Hi-Pot 2121VDC line to earth ground for 3 seconds
 4242VDC Input to Output for 3 seconds
 Safety ApprovalsUL/cUL (UL60065), TUV & IEC 60950-1
 EMC Standards meets FCC class B, CISPR 22 Class B
 RoHS Compliant

PSU meets requirements of following immunity regulations:
 EN 61000-4-2, EN 61000-4-3, EN 61000-4-4, EN 61000-4-5,
 EN 61000-4-6, EN 61000-4-11

Stontronics Ltd is ISO 9001:2008 registered.

