

date: 27.01.2011 16:55
 issued by:ht
 version: 1.0
 27.01.2011 16:55

Technical data

Nominal capacitance	C_N	47 $\mu\text{F} \pm 10\%$
Nominal voltage dc	U_{NDC}	900 V
Surge voltage	U_S	1800 V
Energy	W_N	33.3 Ws
Nominal current @ 10kHz	I_N	90 A
Max. Peak current continuously	\hat{I}	2000 A
Max. Pulse rise time	$\Delta U/\Delta t$	42.3 V/ μs
Series resistance @ 10 kHz	R_{ESR}	<2 m Ω
Dissipation factor @1 kHz	$\tan\delta$	<10 $\times 10^{-4}$

Max. Power Loss
 @hotspot 85°C natural convection, and @10kHz

I_{max}	@ ϑ_{case}	P_{case}
76°	40°C	9.1W
64A	50°C	6.4W
53°	60°C	4.6W
45A	70°C	3.2W

U_N -Derating

U_{Nmax}	@ ϑ_{case}
$U_N \times 1$	$\leq 70^\circ\text{C}$
$U_N \times 0,9$	$\leq 75^\circ\text{C}$
$U_N \times 0,8$	$\leq 80^\circ\text{C}$
$U_N \times 0,7$	$\leq 85^\circ\text{C}$

Min. Operating temperature	ϑ_{min}	-40 °C
Max. Operating temperature ($I_R = 0$)	ϑ_{max}	+85 °C
Storage temperature	ϑ_{Store}	-40...+85 °C
Thermal resistance (case hotspot)	R_{th}	4.2 °C/W
Climatic category DIN IEC 68/1		40/085/21

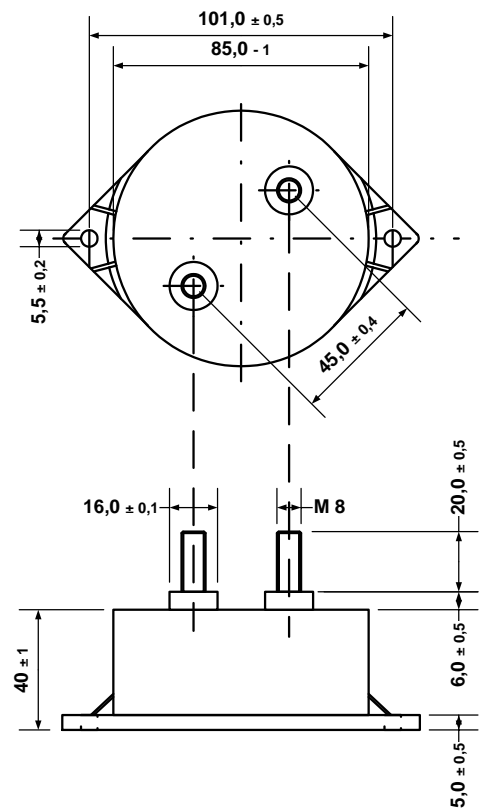

Test Data

Test voltage between terminations U_{TT} 1800 V dc / 2s

Life expectancy @ hot spot 70°C 100 000 h

General technical data

Coating	plastic case with resin sealing Flame retardant according to UL 94V-0
Dielectric	polypropylene
Terminals	Nickel plated brass, max torque 6Nm
Weight	~ 300g