

Application: DC/AC capacitor for general use in power electronics
 also for nonsinusoidal voltages and currents

Order code: PPM 90-80.0 dv (K)

Standards: acc. to IEC 61071:2007

Characteristics

Rated capacitance	C_N	80 μF ±10%
Rated d.c. voltage	U_{NDC}	900 V d.c.
Rated a.c. voltage	U_{NAC}	400 V a.c.
Max. rms voltage (sinusoidal)	U_{rms}	280 V
Non-recurrent surge voltage	u_s	1350 V
Rated energy	W_N	32.4 Ws
Maximum current	I_{max}	80 A
Maximum peak current	I_̂	2 kA
Maximum surge current	I_s	6 kA
Series resistance	R_s	0.25 mΩ
Tangent of the loss angle	tanδ_o	2 x 10 ⁻⁴
Self discharge time const.	C x R_{is}	5000 s
Self-inductance	Le	15 nH

outline drawing

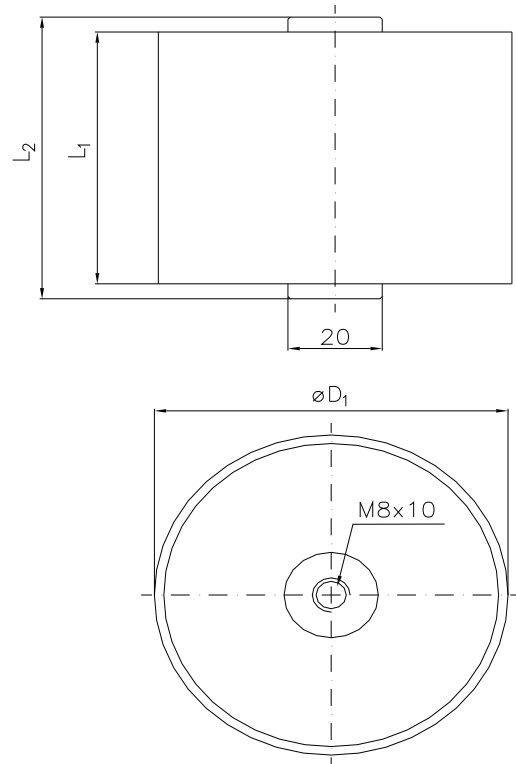

Thermal conditions

Lowest operating temperature	Θ_{min}	-25 °C
Maximum operating temperature	Θ_{max}	85 °C
Storage temperature	Θ_{storage}	-40..+85 °C
Thermal resistance	R_{th}	4.7 K/W
Humidity class		G

failure rate

reference service life at Θ_{hotspot}: 100 FIT*
 100000 h
 ≤ 70 °C

* See FIT-RATE diagram on pg.3

Test data

Voltage test between terminals	U_{TT}	1350 V DC/10s
--------------------------------	-----------------------	---------------

Dimensions

Rated diameter	D₁	105 (±1) mm
Length of the case	L₁	59 (±1) mm
total Length	L₂	66 (±1) mm
Terminal	G	M8 x 10 mm
Diameter of terminals	D₂	20 mm
Clearance in air	L	129 mm
Creepage distance	K	134 mm

Approx weight

0.55 kg

Mechanical characteristics

Dielectric: metallized polypropylene capacitor, selfhealing
 Construction: plastic case with resin moulded winding, UL94: V0
 Protection: without internal fuse, to be used only in uncritical environment
 Terminals: screw base, inside thread
 Impregnant: no liquid impregnants, filled with solidified PUR resin, non PCB
 Fire load: 22.0MJ