

DPM 100-BL

3½ Digit Backlit LCD Module

A low cost, low power LCD panel meter with a true digital hold of displayed reading. With its high accuracy and few connections, this meter is particularly suited to high volume applications. The DPM 100-BL is supplied complete with a flat, reverse printed window and snap-in bezel. Very low current consumption gives long battery life, making it especially useful in portable equipment.

- 🔊 12.5mm (0.5") Digit Height
- 🔊 Logic Selectable Decimal Points
- 🔊 Auto-zero
- 🔊 Auto-polarity
- 🔊 200mV d.c. Full Scale Reading (F.S.R.)
- 🔊 LED Backlit
- 🔊 Digital Hold



SCALING

Two resistors Ra and Rb may be fitted in order to alter the full scale reading of the meter - see table. Meter will need re-calibration.

| Required F.S.R. | | Ra | Rb |
|-----------------|------|------|------|
| 2V | Note | 910k | 100k |
| 20V | Note | 1M | 10k |
| 200V | Note | 1M | 1k |
| 2kV | Note | 1M | 100R |
| 200µA | | 0R | 1k |
| 2mA | | 0R | 100R |
| 20mA | | 0R | 10R |
| 200mA | | 0R | 1R |

NOTE
Ensure link La is cut if fitting Ra.

SAFETY

To comply with the Low Voltage Directive (LVD 93/68/EEC), input voltages to the module's pins must not exceed 60Vdc. If voltages to the measuring inputs do exceed 60Vdc, then fit scaling resistors externally to the module. The user must ensure that the incorporation of the DPM into the user's equipment conforms to the relevant sections of BS EN 61010 (Safety Requirements for Electrical Equipment for Measuring, Control and Laboratory Use).

| Backlit Meter | | Stock Number DPM 100-BL | | |
|----------------------------------|-------------------|----------------------------|------|--------------|
| Specification | Min. | Typ. | Max. | Unit |
| Accuracy (overall error) * | | 0.05 | 0.1 | % (±1 count) |
| Linearity | | | ±1 | count |
| Sample rate | | 3 | | samples/sec |
| Operating temperature range | 0 | | 50 | °C |
| Supply voltage | 7.5 | 9 | 14 | Vd.c. |
| Supply current | (excl. backlight) | 300 | | µA |
| | (incl. backlight) | 30 | | mA |
| Temperature stability | | 100 | | ppm/°C |
| Input leakage current (Vin = 0V) | | 1 | 10 | pA |

* To ensure maximum accuracy, re-calibrate periodically.

DIMENSIONS All dimensions in mm (inches)

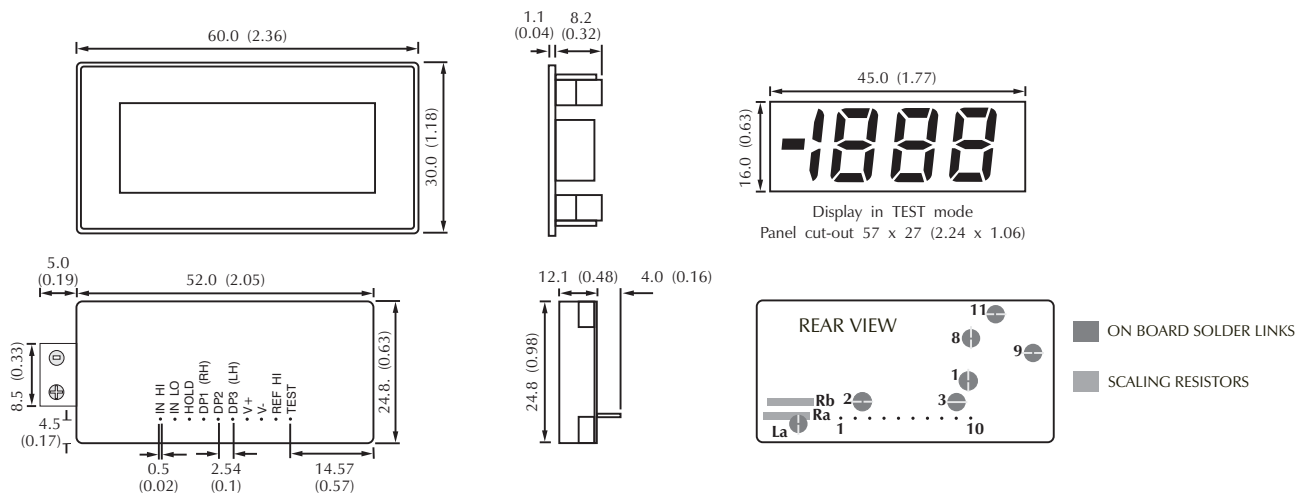

PANEL FITTING

Fit the bezel to the front of the panel and then locate the meter into the bezel from behind. Alternatively the meter and bezel may be assembled before fitting into the front of the panel but care must be taken not to use excessive force. Finally fit the window into the front of the bezel.

PIN FUNCTIONS

1. INHI Positive measuring input.] Analogue inputs must be no closer than 1V to either the positive or negative supply.
2. INLO Negative measuring input.]
- Note: This pin is tied by Link 2 to COM. This link should be open for any application where the supply voltage is not fully floating. If open, ensure the inputs are restricted to the common mode range. Com is held internally at 2.8V below V+ and must not be allowed to sink excessive current (>100µA) by, for instance, connecting to a higher voltage. See note on REF HI (pin 9).
3. HOLD If left floating or connected to TEST (pin 10), the meter will continuously measure the input voltage. When connected to V+ the last displayed reading will be held indefinitely.
4. DP1 Connect to V+ to display 199.9
5. DP2 Connect to V+ to display 19.99
6. DP3 Connect to V+ to display 1.999
7. V+ Positive power supply.
8. V- Negative power supply.
9. REFHI Positive input for reference voltage. This input is isolated by Link 3. By shorting Link 3 and opening Link 1, the meter can be used in ratio metric mode or with an external reference. The reference voltage is referred to COM and the internal reference is derived from the voltage between V+ and COM. If COM is pulled down, then an external reference must be provided.
10. TEST Connect to V+ to display segments as illustrated. It should not be operated for more than a few seconds as the d.c. voltage applied to the LCD may 'burn' the display. This pin is normally at 5V below V+ and is the ground for the digital section of the meter. It can be used to power external logic up to a maximum of 1mA.

DPM 100-BL

Apply 5V d.c. to the backlight tab on the side of the meter. Typical current is 30mA. For higher voltages fit a resistor in series.
 E.g. For 9V use 150Ω. Maximum current = 60mA.

SPECIAL NOTE: ANNUNCIATORS

The DPM 100-BL annunciators (A, °F, °C etc.) can be selected by applying a solder link to the XDP pad. The pads are tied via links to the backplane in order to suppress the annunciators when not wanted. Care should be taken to ensure that links to BP are open before connecting annunciator pads to the XDP pad.

VARIOUS OPERATING MODES

ON-BOARD LINKS: In order to quickly and easily change operating modes for different applications, the meter has several on-board links. They are designed to be easily opened (cut) or shorted (soldered). Do not connect more than one meter to the same power supply if the meters cannot use the same signal ground. Taking any input beyond the power supply rails will damage the meter.

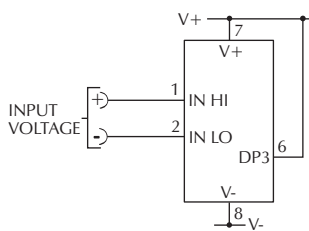

Check Links 1 & 2 are SHORTED.

Measuring a floating voltage source of 200mV full scale and displaying DP3.

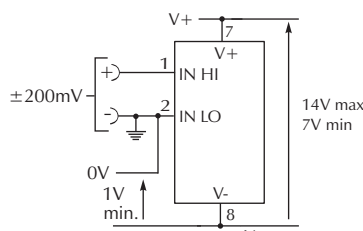

Check Link 2 is OPEN.

Split supply operation.

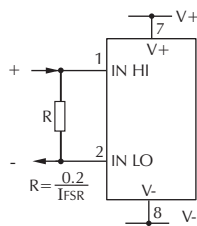

Check Links 1 & 2 are SHORTED.

Measuring current. Supply MUST be isolated.

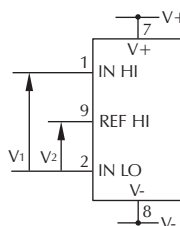

Check Link 1 is OPEN.
 SHORT Link 3.

Measuring the ratio of two voltages.
 Reading = 1000 V₁/V₂
 50mV < V₂ < 200mV
 V₁ < 2V₂.

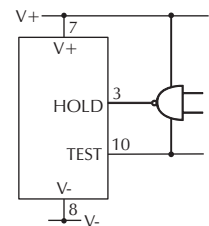

Driving HOLD from external logic.
 Logic powered from V+ (7) to TEST (10).