

HIGH-TEMPERATURE, 80V N-CHANNEL SMALL SIGNAL MOSFET

FEATURES

- ▲ Minimum $BV_{DSS} = 90V$.
- ▲ Allowed V_{GS} range $-5.5V$ to $+5.5V$.
- ▲ Operational beyond the $-60^{\circ}C$ to $+230^{\circ}C$ temperature range.
- ▲ Low $R_{DS(on)}$
 - XTR2N0807: $9.1 \Omega @ 230^{\circ}C$
- ▲ Maximum I_D :
 - XTR2N0807: $420mA @ 230^{\circ}C$
- ▲ On-time ($t_{d(on)}+t_r$):
 - XTR2N0807: $26.5nsec @ 230^{\circ}C$
- ▲ Off-time ($t_{d(off)}+t_f$):
 - XTR2N0807: $27nsec @ 230^{\circ}C$
- ▲ Available in ruggedized SMT and thru-hole packages.
- ▲ Parts are also available as bare dies.

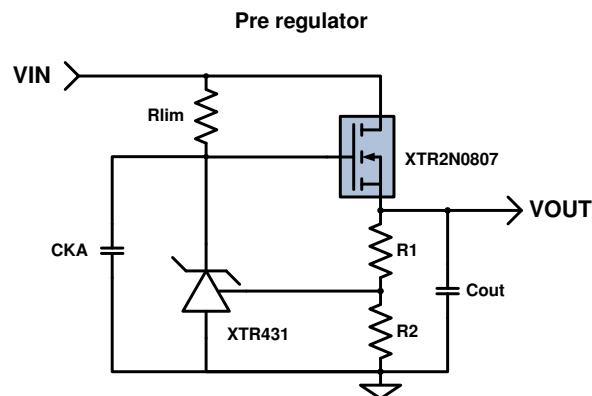
DESCRIPTION

XTR2N0807 is an N-channel small signal MOSFETs designed to reliably operate over a wide range of temperatures. Full functionality is guaranteed from $-60^{\circ}C$ to $+230^{\circ}C$, though operation well below and above this temperature range is achieved. Fabricated on a Silicon-on-Insulator (SOI) process, XTR2N0807 family parts offer reduced leakage currents while providing high drain currents and low $R_{DS(on)}$. These features allow XTR2N0807 parts to be ideally suited for switching applications. XTR2N0807 family parts have been designed to reduce system cost and ease adoption by reducing the learning curve and providing smart and easy to use features. XTR2N0807 parts are available ruggedized SMT and thru-hole packages. Parts are also available as bare dies.

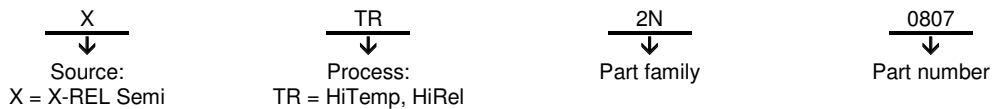
APPLICATIONS

- ▲ Reliability-critical, Automotive, Aeronautics & Aerospace, Down-hole.
- ▲ Linear regulators, switching applications, sensor driving, level shifting.

PRODUCT HIGHLIGHT



ORDERING INFORMATION



Product Reference	Temperature Range	Package	Pin Count	Marking
XTR2N0807-BD	$-60^{\circ}C$ to $+230^{\circ}C$	Bare die		XTR2N0807
XTR2N0807-TD	$-60^{\circ}C$ to $+230^{\circ}C$	Tested bare die		XTR2N0807
XTR2N0807-FE	$-60^{\circ}C$ to $+230^{\circ}C$	Gull-wing flat pack with ePad	8	XTR2N0807
XTR2N0807-T	$-60^{\circ}C$ to $+230^{\circ}C$	TO-18	3	XTR2N0807

Other packages and packaging configurations possible upon request.

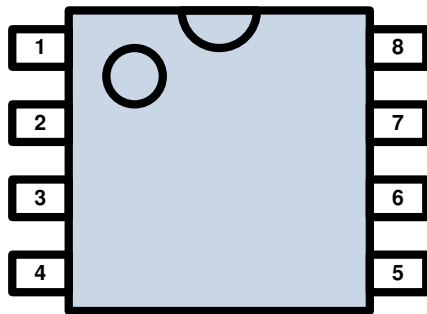
ABSOLUTE MAXIMUM RATINGS

Drain-source voltage	-2V to +90V
Gate-source voltage	±6.0V
Storage temperature range	-70°C to +230°C
Operating junction temperature range	-70°C to +300°C
ESD classification	1kV HBM MIL-STD-750

Caution: Stresses beyond those listed in “ABSOLUTE MAXIMUM RATINGS” may cause permanent damage to the device. These are stress ratings only and functionality of the device at these or any other condition beyond those indicated in the operational sections of the specifications is not implied. Exposure to “ABSOLUTE MAXIMUM RATINGS” conditions for extended periods may permanently affect device reliability.

PRODUCT VARIANTS
CDFP8 with ePad

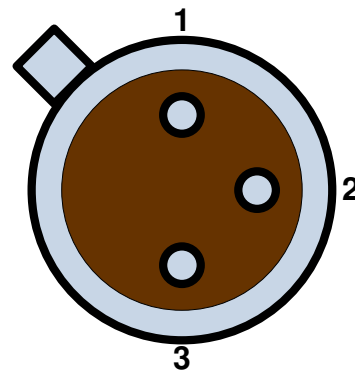
Top view



1, 2, 3 SOURCE
 4 GATE
 5, 6, 7, 8 DRAIN

TO-18

Bottom view



1 GATE
 2 DRAIN
 3 SOURCE
 Package case SOURCE

RECOMMENDED OPERATING CONDITIONS

Parameter	Min	Typ	Max	Units
Drain-source voltage V_{DS}	-1.5		80	V
Gate-source voltage V_{GS}	-5.5		+5.5	V
Junction Temperature ¹ T_j	-60		230	°C

¹ Operation beyond the specified temperature range is achieved.

THERMAL CHARACTERISTICS

Parameter	Condition	Min	Typ	Max	Units
XTR2N0307-T (TO-18)					
Thermal Resistance: J-C $R_{Th\ J-C}$			55		°C/W
Thermal Resistance: J-A $R_{Th\ J-A}$			300		°C/W
XTR2N0307-FE (DFP8)					
Thermal Resistance: J-C $R_{Th\ J-C}$	Resistance to exposed pad.		15		°C/W

Thermal Resistance: J-A $R_{Th\ J-A}$			TBD		°C/W
--	--	--	-----	--	------

XTR2N0807 SPECIFICATIONS

 Unless otherwise stated, specification applies for $-60^{\circ}\text{C} < T_j < 230^{\circ}\text{C}$.

Parameter	Condition	Min	Typ	Max	Units
DC Characteristics					
Drain-source breakdown voltage BV_{DSS}	$V_{GS}=0V, I_{DS}=100\mu A, T_j=25^{\circ}\text{C}$	90			V
Static drain-source on-state resistance $R_{DS(on)}$	$V_{GS}=+5V, I_{DS}=100mA$ $T_C=-60^{\circ}\text{C}$ $T_C=85^{\circ}\text{C}$ $T_C=230^{\circ}\text{C}$		3.9 6.3 9.1	5.9 9.4 13.6	Ω
Continuous drain current $I_{D(DC)}$	$V_{GS}=+5V$ $T_C=-60^{\circ}\text{C}$ $T_C=85^{\circ}\text{C}$ $T_C=230^{\circ}\text{C}$		250 200 130		mA
Gate threshold voltage $V_{GS(th)}$	$V_{DS}=V_{GS}, T_j=25^{\circ}\text{C}, I_{DS}=1mA$		1.55	1.75	V
Temperature drift of gate threshold voltage $\Delta V_{GS(th)}/\Delta T_j$	$V_{DS}=V_{GS}, I_{DS}=1mA$		-2.25		mV/°C
Off-state drain current I_{DSS}	$V_{DS}=80V, V_{GS}=0V$ $T_C=-60^{\circ}\text{C}$ $T_C=85^{\circ}\text{C}$ $T_C=230^{\circ}\text{C}$		0.0005 0.005 2.0	0.01 0.03 15	μA
Off-state gate current I_{GSS}	$V_{GS}=\pm 5V, V_{DS}=0V$ $T_C=-60^{\circ}\text{C}$ $T_C=85^{\circ}\text{C}$ $T_C=230^{\circ}\text{C}$		± 0.07 ± 0.3 ± 85	± 0.5 ± 2 ± 200	nA
AC Characteristics					
Input capacitance C_{iss}	$V_{DS}=80V, V_{GS}=0V, f=1MHz$		76		pF
Output capacitance C_{oss}			19		pF
Reverse transfer capacitance C_{rss}			8		pF
Switching Characteristics					
Pulsed drain current I_{DM}	$V_{DS}=80V, V_{GS\ sweep}=0\ to\ +5V, d=0.2\%, \tau=1ms$ $T_C=-60^{\circ}\text{C}$ $T_C=85^{\circ}\text{C}$ $T_C=230^{\circ}\text{C}$		830 660 420		mA
Total gate charge Q_g	$V_{DS}=80V, V_{GS\ sweep}=0\ to\ +5V$		1.5		nC
Turn-on delay time $t_{d(on)}$	$V_{DS}=20V, V_{GS\ sweep}=0\ to\ +5V, d=0.2\%, \tau=1ms$		19.5		ns
Rise time t_r	$V_{DS}=20V, V_{GS\ sweep}=0\ to\ +5V, d=0.2\%, \tau=1ms$		7.0		
Turn-off delay time $t_{d(off)}$	$V_{DS}=20V, V_{GS\ sweep}=+5\ to\ 0V, d=0.2\%, \tau=1ms$		18.5		
Fall time t_f	$V_{DS}=20V, V_{GS\ sweep}=+5\ to\ 0V, d=0.2\%, \tau=1ms$		8.5		

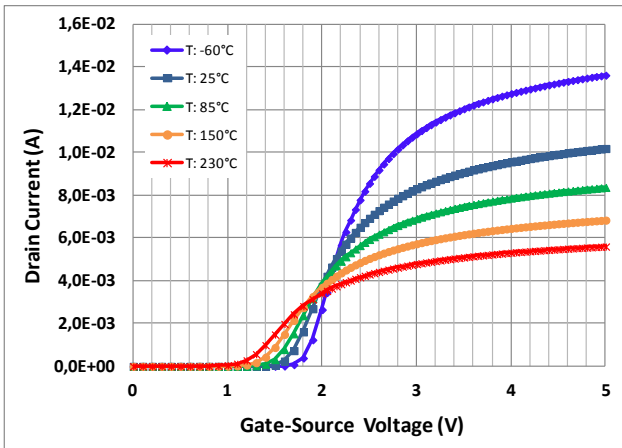
TYPICAL PERFORMANCE


Figure 1. Drain Current (I_{DS}) vs Gate-Source Voltage for several case temperatures. $V_{DS}=50mV$.

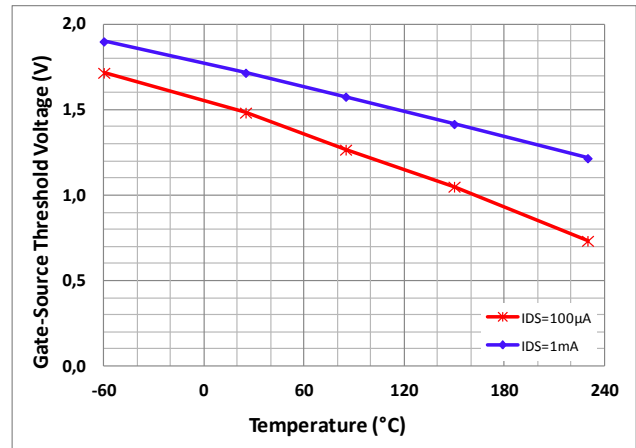


Figure 2. Gate-Source Threshold Voltage ($V_{GS(th)}$) vs Gate-Source Voltage for several case temperatures. $V_{DS}=50mV$.

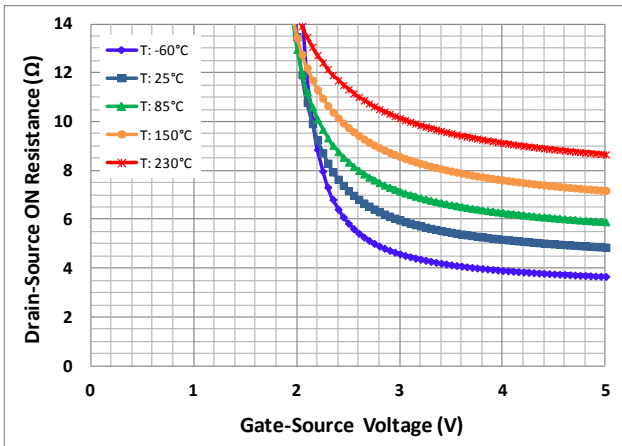


Figure 3. Drain-Source ON Resistance ($R_{DS(on)}$) vs Gate-Source Voltage for several case temperatures. $V_{DS}=50mV$.

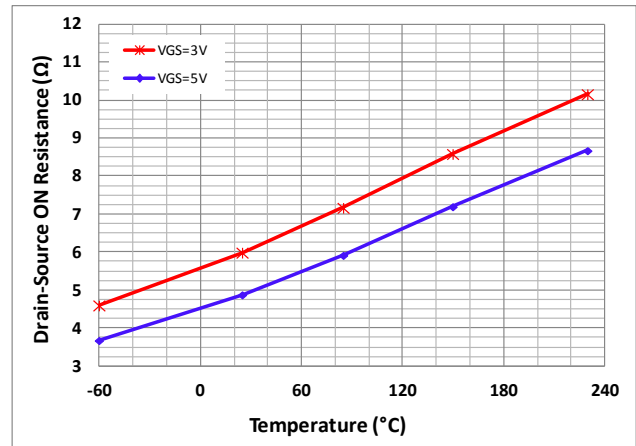


Figure 4. Drain-Source ON Resistance ($R_{DS(on)}$) vs Gate-Source Voltage for several case temperatures. $V_{DS}=50mV$.

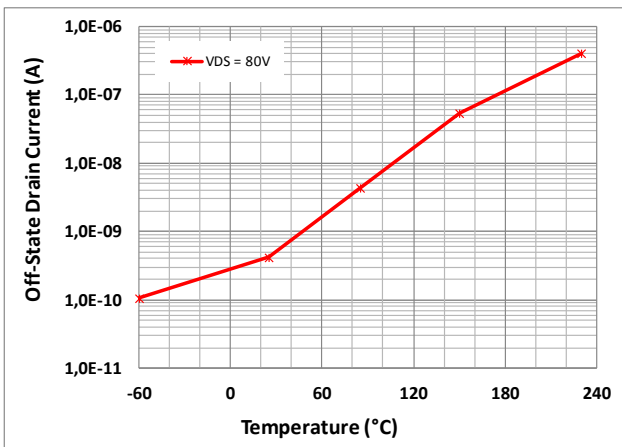


Figure 5. Off-State Drain Current (I_{DSS}) vs Case Temperature. $V_{DS}=80V$, $V_{GS}=0V$.

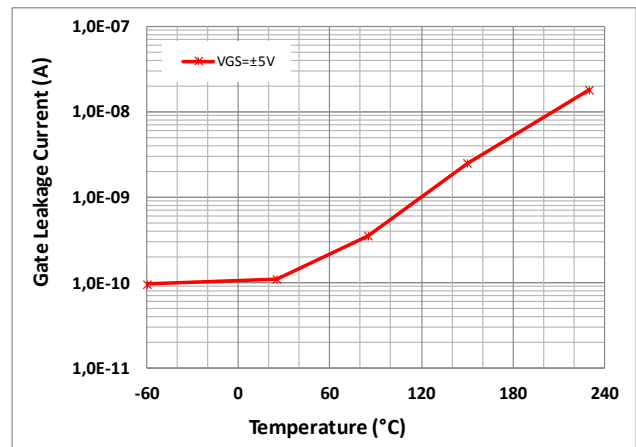


Figure 6. Gate Leakage Current (I_{GSS}) vs Case Temperature. $V_{GS}=\pm 5V$, $V_{DS}=0V$.

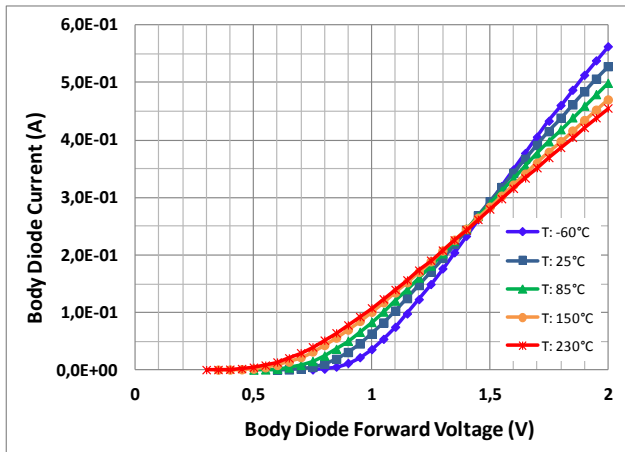


Figure 7. Body Diode Forward Current (I_{FD}) vs Forward Voltage for several case temperature. $V_{GS}=0V$.

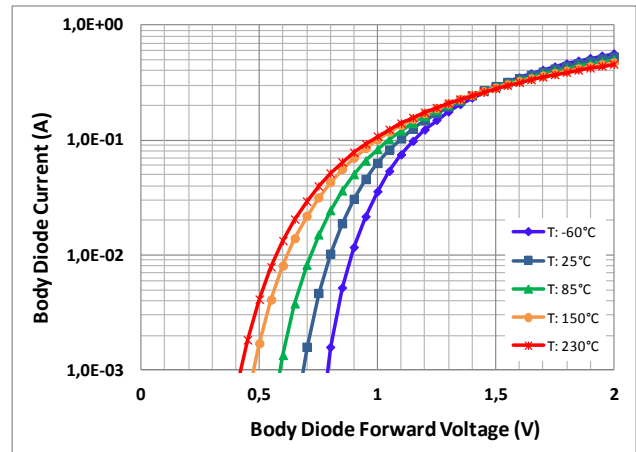
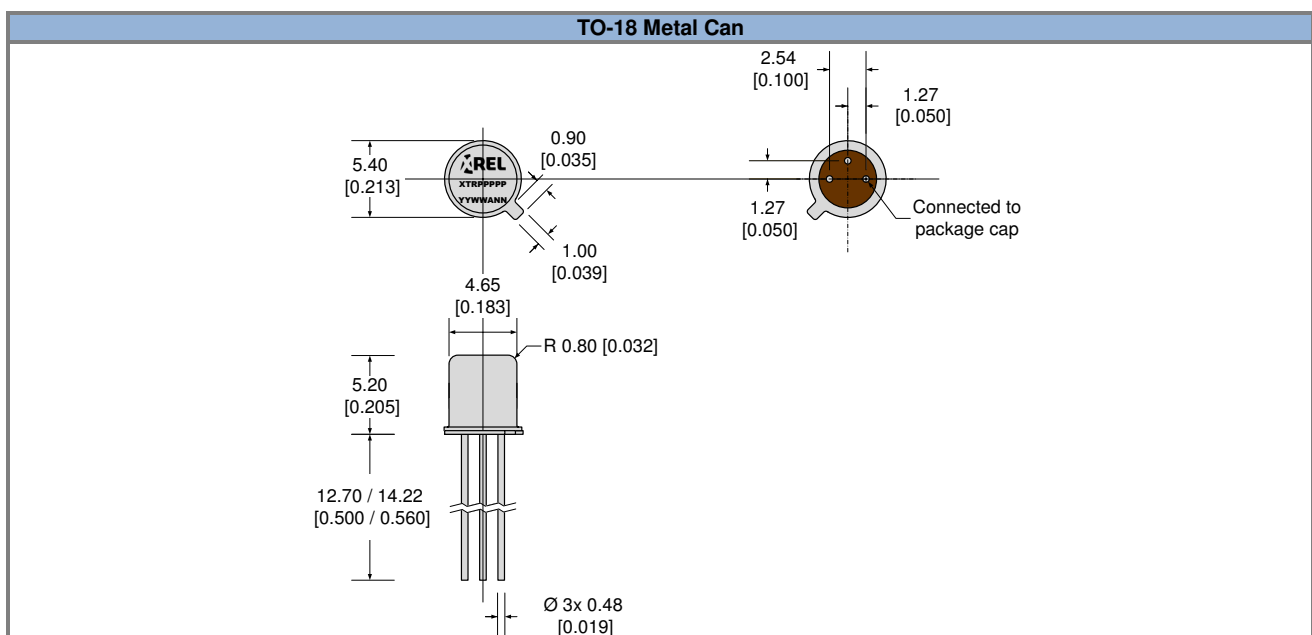
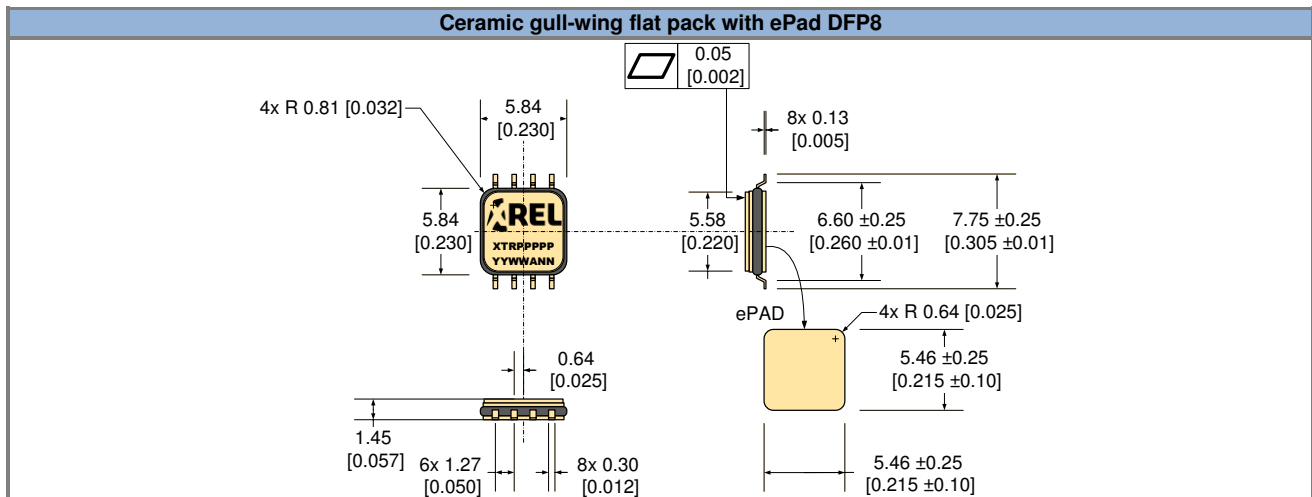


Figure 8. Body Diode Forward Current (I_{FD}) in logarithmic scale vs Forward Voltage for several case temperature. $V_{GS}=0V$.

PACKAGE OUTLINES

Dimensions shown in mm [inches].



Part Marking Convention	
Part Reference: XTRPPPPP	
XTR	X-REL Semiconductor, high-temperature, high-reliability product (XTRM Series).
PPPPP	Part number (0-9, A-Z).
Unique Lot Assembly Code: YYWWANN	
YY	Two last digits of assembly year (e.g. 11 = 2011).
WW	Assembly week (01 to 52).
A	Assembly location code.
NN	Assembly lot code (01 to 99).

IMPORTANT NOTICE & DISCLAIMER

Information in this document supersedes and replaces all information previously supplied. Information in this document is provided solely in connection with X-REL Semiconductor products.

The information contained herein is believed to be reliable. X-REL Semiconductor makes no warranties regarding the information contained herein. X-REL Semiconductor assumes no responsibility or liability whatsoever for any of the information contained herein. X-REL Semiconductor assumes no responsibility or liability whatsoever for the use of the information contained herein. The information contained herein is provided "AS IS, WHERE IS" and with all faults, and the entire risk associated with such information is entirely with the user. X-REL Semiconductor reserves the right to make changes, corrections, modifications or improvements, to this document and the information herein without notice. Customers should obtain and verify the latest relevant information before placing orders for X-REL Semiconductor products. The information contained herein or any use of such information does not grant, explicitly or implicitly, to any party any patent rights, licenses, or any other intellectual property rights, whether with regard to such information itself or anything described by such information.

Unless expressly approved in writing by an authorized representative of X-REL Semiconductor, X-REL Semiconductor products are not designed, authorized or warranted for use in military, aircraft, space, life saving, or life sustaining applications, nor in products or systems where failure or malfunction may result in personal injury, death, or property or environmental damage.

General Sales Terms & Conditions apply.

CONTACT US

For more information on X-REL Semiconductor's products, technical support or ordering:

- ✓ Web: www.x-relsemi.com/products
- ✓ Tel: +33 456 580 580
- ✓ Fax: +33 456 580 599
- ✓ Sales: sales@x-relsemi.com
www.x-relsemi.com/EN/Sales-Representatives
- ✓ Information: info@x-relsemi.com
- ✓ Support: support@x-relsemi.com

X-REL Semiconductor

90, Avenue Léon Blum
38100 Grenoble
France