

HIGH-TEMPERATURE, 40V DIODE FAMILY

FEATURES

- ▲ Reverse voltage $V_R > 55V$.
- ▲ Operational beyond the $-60^\circ C$ to $+230^\circ C$ temperature range.
- ▲ Forward current @ $230^\circ C$, $V_F=1.2V$:
 - XTR1N0415: $I_F=320mA$ per diode.
 - XTR1N0450: $I_F=1150mA$ per diode.
- ▲ Forward voltage @ $25^\circ C$, $I_F=1mA$:
 - XTR1N0415: $V_F=725mV$ per diode.
 - XTR1N0450: $V_F=715mV$ per diode.
- ▲ Ruggedized SMT and thru-hole packages.
- ▲ Also available as bare die.

APPLICATIONS

- ▲ Reliability-critical, Automotive, Aeronautics & Aerospace, Down-hole.
- ▲ General rectification, voltage blocking and clamping, power supplies.

DESCRIPTION

XTR1N0400 is a family of general purpose diodes with a reverse voltage above 55V. Each part is composed of four independent diodes which can be used individually, in half- or full-bridge rectifier architecture or connected in series or parallel. Typical applications include rectification, demodulation, voltage blocking, voltage clamping, power supplies, charge pumps and voltage multipliers. Full functionality is guaranteed from $-60^\circ C$ to $+230^\circ C$, though operation well below and above this temperature range is achieved. XTR1N0400 parts have been designed to reduce system cost and ease adoption by reducing the learning curve and providing easy to use features. Parts from the XTR1N0400 family are available in ruggedized SMT and thru-hole packages. Parts are also available as bare dies.

PRODUCT HIGHLIGHT

Diodes used in half- and full-bridge rectification as well as voltage clamping

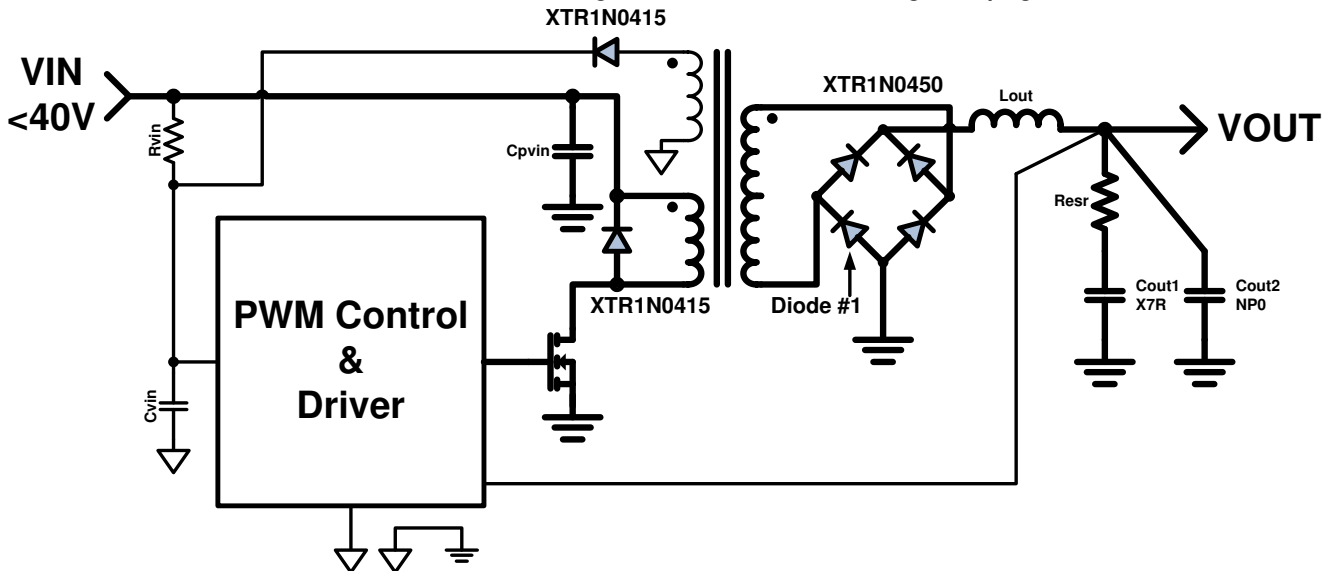

ORDERING INFORMATION

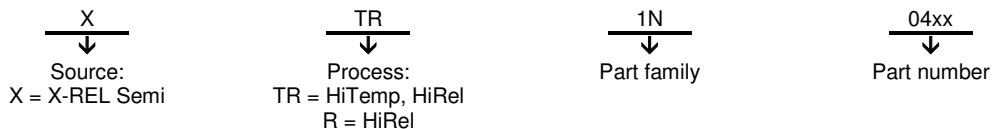

Product Reference	Temperature Range	Package	Pin Count	Marking
XTR1N0415-TD	$-60^\circ C$ to $+230^\circ C$	Tested bare die		XTR1N0415
XTR1N0450-TD	$-60^\circ C$ to $+230^\circ C$	Tested bare die		XTR1N0450
XTR1N0415-D	$-60^\circ C$ to $+230^\circ C$	Ceramic side brazed DIP	8	XTR1N0415
XTR1N0415-FE	$-60^\circ C$ to $+230^\circ C$	Gull-wing flat pack with ePad	8	XTR1N0415
XTR1N0450-D	$-60^\circ C$ to $+230^\circ C$	Ceramic side brazed DIP	8	XTR1N0450

Other packages and packaging configurations possible upon request.

ABSOLUTE MAXIMUM RATINGS

Repetitive peak reverse voltage V_{RRM}	55V
Continuous peak reverse voltage V_R	55V
Continuous forward current I_F @230°C	
XTR1N0415	0.79A
XTR1N0450	2.80A
Operating Junction Temperature Range	-70°C to +300°C

Caution: Stresses beyond those listed in “ABSOLUTE MAXIMUM RATINGS” may cause permanent damage to the device. These are stress ratings only and functionality of the device at these or any other condition beyond those indicated in the operational sections of the specifications is not implied. Exposure to “ABSOLUTE MAXIMUM RATINGS” conditions for extended periods may permanently affect device reliability.

PACKAGING OPTIONS

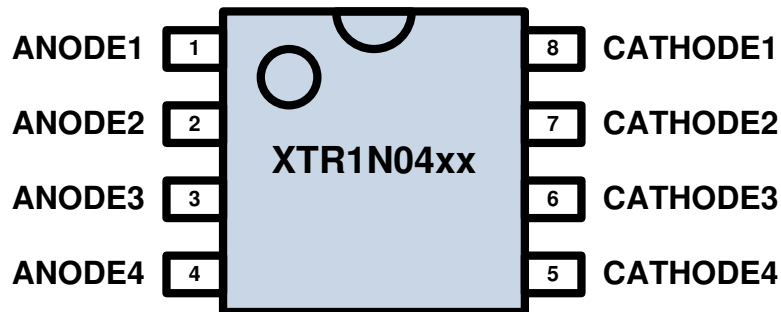

BLOCK DIAGRAM

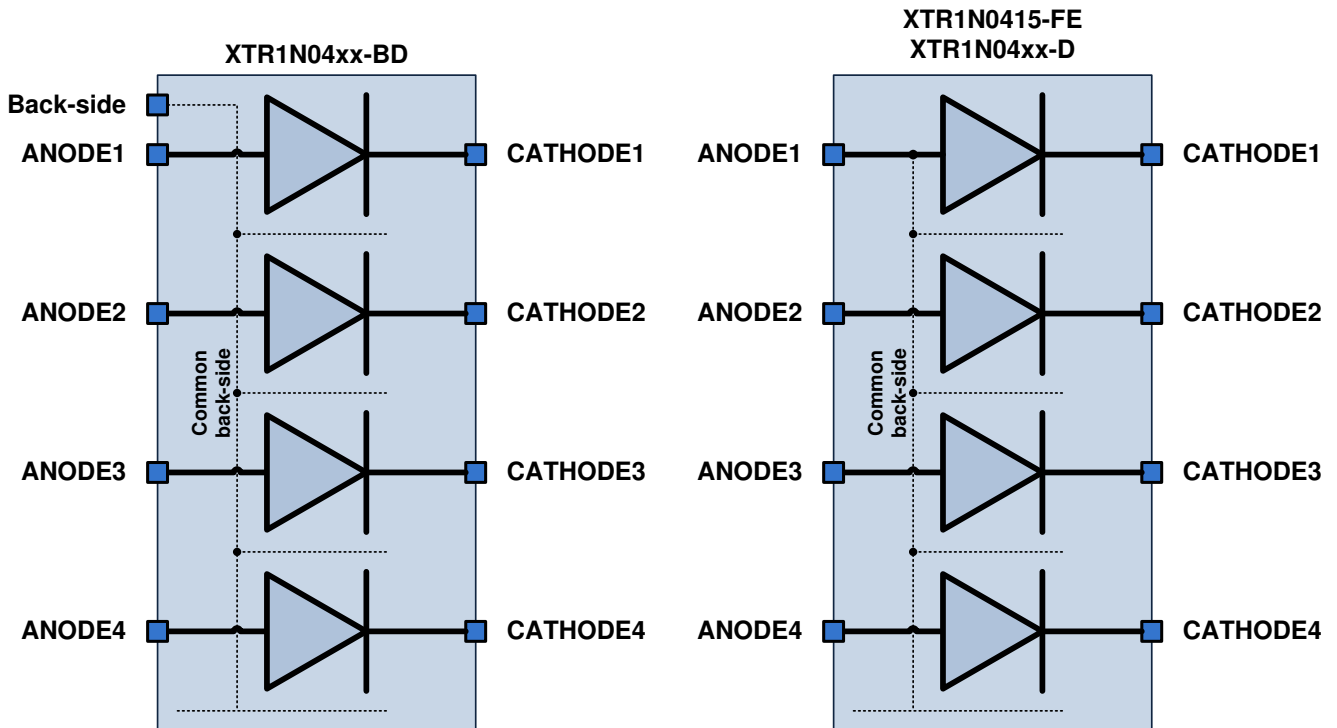

ePAD on bottom of package in “FE” option connected to ANODE1. ePAD can be left floating on the PCB.

Important Notices:

Dashed lines indicate the back side connection. In the packaged versions (XTR1N04xx-D and XTR1N0415-FE), the back-side is connected to the anode of the first diode (ANODE1). For best reverse voltage performance, the back-side must be connected to the most possible negative voltage seen by any of the four diodes.

In case a diode is not used, the diode should be shorted and tied to a fixed voltage in the application or at least to a terminal of any active diode.

RECOMMENDED OPERATING CONDITIONS

Parameter	Min	Typ	Max	Units
Reverse voltage V_R			40	V
Forward voltage V_F			1.5	V
Continuous forward current per diode @ $V_F=1.5V$, $T_j=25^\circ C$ I_F XTR1N0415 XTR1N0450		0.53 1.90		A
Junction Temperature ¹ T_j	-60		230	$^\circ C$

¹ Operation beyond the specified temperature range is achieved.

XTR1N0415 ELECTRICAL SPECIFICATIONS

Unless otherwise stated, specification applies for one diode and $-60^\circ C < T_j < 230^\circ C$.

Parameter	Condition	Min	Typ	Max	Units
Electrical Characteristics					
Forward Voltage V_F	$I_F=1mA$ $T_j=-60^\circ C$ $T_j=25^\circ C$ $T_j=85^\circ C$ $T_j=230^\circ C$		855 725 625 380		mV
Forward Current I_F	$V_F=1.2V$ $T_j=-60^\circ C$ $T_j=25^\circ C$ $T_j=85^\circ C$ $T_j=230^\circ C$		240 275 295 320		mA
Reverse Current I_R	$V_R=40V$ $T_j=25^\circ C$ $T_j=85^\circ C$ $T_j=230^\circ C$		<0.001 0.005 1.8		μA
Switching Characteristics					
Diode Capacitance C_d	$F=1MHz, V_R=0V$ $F=1MHz, V_R=40V$		56 18		pF
Reverse Recovery Time t_{rr}	$I_F=10mA, V_R=-6V, T_j=25^\circ C$ $I_F=100mA, V_R=-6V, T_j=25^\circ C$		73 27		ns
Forward Recovery Voltage V_{fr}			TBD		V

XTR1N0450 ELECTRICAL SPECIFICATIONS

Unless otherwise stated, specification applies for one diode and $-60^\circ C < T_j < 230^\circ C$.

Parameter	Condition	Min	Typ	Max	Units
Electrical Characteristics					
Forward Voltage V_F	$I_F=1mA$ $T_j=-60^\circ C$ $T_j=25^\circ C$ $T_j=85^\circ C$ $T_j=230^\circ C$		845 715 615 370		mV
Forward Current I_F	$V_F=1.2V$ $T_j=-60^\circ C$ $T_j=25^\circ C$ $T_j=85^\circ C$ $T_j=230^\circ C$		0.86 0.99 1.06 1.15		A
Reverse Current I_R	$V_R=40V$ $T_j=25^\circ C$ $T_j=85^\circ C$ $T_j=230^\circ C$		<0.005 0.020 6.5		μA
Switching Characteristics					
Diode Capacitance C_d	$F=1MHz, V_R=0V$ $F=1MHz, V_R=40V$		201 65		pF
Reverse Recovery Time t_{rr}	$I_F=35mA, V_R=-6V, T_j=25^\circ C$ $I_F=350mA, V_R=-6V, T_j=25^\circ C$		73 27		ns
Forward Recovery Voltage V_{fr}			TBD		V

THEORY OF OPERATION

Introduction

The XTR1N0400 is a family of general purpose diodes able to operate from -60°C to $+230^{\circ}\text{C}$ and withstand reverse voltages up to 55V.

Each die is composed of four independent diodes on top of the same silicon substrate (back-side connection).

Given the construction of the diodes, the back-side voltage has an influence on the maximum allowed reverse voltage. Optimum performance is achieved for the back-side connected to the most negative voltage seen by any of the four diodes. In packaged parts, the back-side is connected to the anode of the first diode (ANODE1).

In the simple full-bridge rectifier example below, if the packaged version of XTR1N0415 or XTR1N0450 is used, the optimum result is achieved by connecting the anode of the first diode to the GND node.

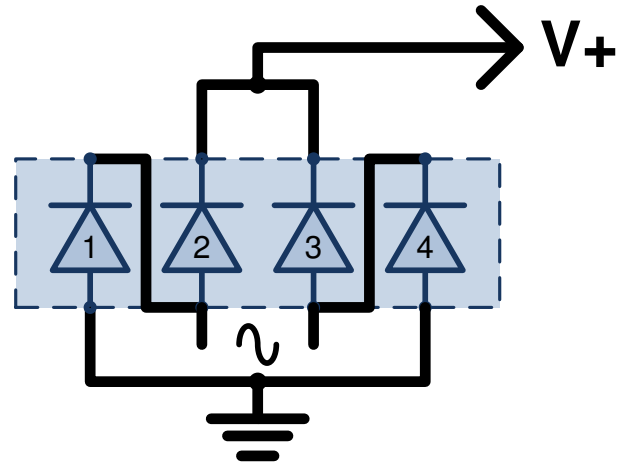

The previous figure shows a simple implementation of the full-bridge rectifier at board level. Bold black lines indicate tracks on the board. In this configuration, as recommended in the previous figure, the anode of the first diode is connected to the GND node in order to offer the best reverse voltage characteristics.

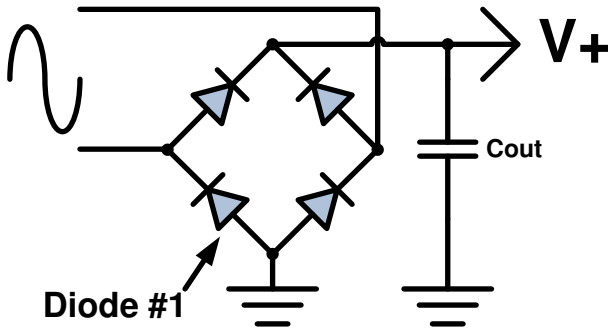

PACKAGE OUTLINES

Dimensions shown in mm [inches]. Tolerance ± 0.13 mm [± 0.005 in], unless otherwise specified.

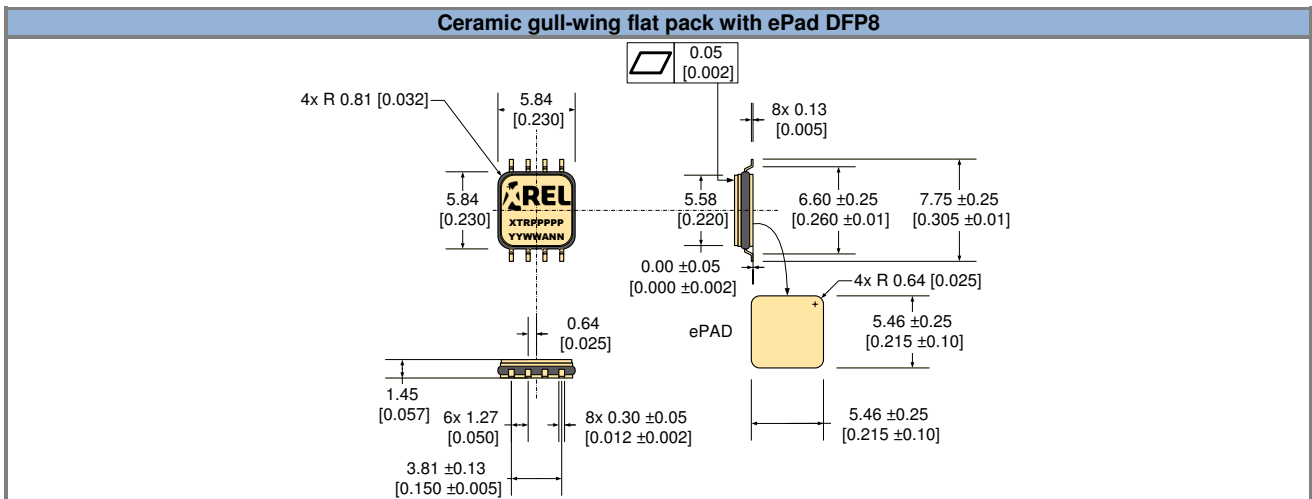

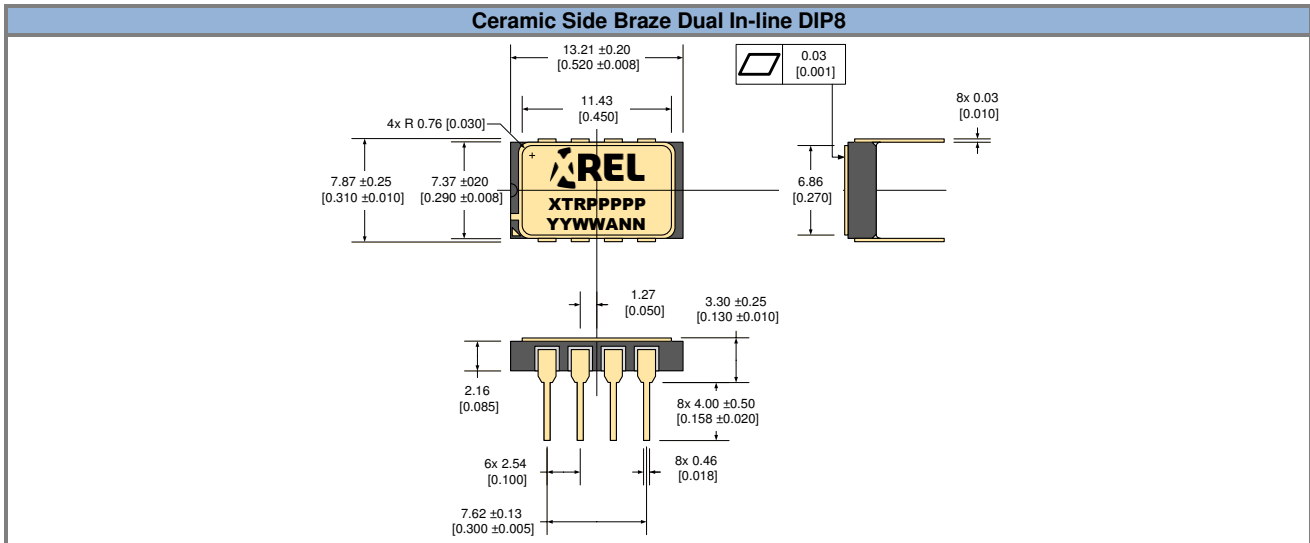

Part Marking Convention

Part Reference: XTRPPPPPP	
XTR	X-REL Semiconductor, high-temperature, high-reliability product (XTRM Series).
PPPPP	Part number (0-9, A-Z).
Unique Lot Assembly Code: YYWWANN	
YY	Two last digits of assembly year (e.g. 11 = 2011).
WW	Assembly week (01 to 52).
A	Assembly location code.
NN	Assembly lot code (01 to 99).

IMPORTANT NOTICE & DISCLAIMER

Information in this document supersedes and replaces all information previously supplied. Information in this document is provided solely in connection with X-REL Semiconductor products.

The information contained herein is believed to be reliable. X-REL Semiconductor makes no warranties regarding the information contained herein. X-REL Semiconductor assumes no responsibility or liability whatsoever for any of the information contained herein. X-REL Semiconductor assumes no responsibility or liability whatsoever for the use of the information contained herein. The information contained herein is provided "AS IS, WHERE IS" and with all faults, and the entire risk associated with such information is entirely with the user. X-REL Semiconductor reserves the right to make changes, corrections, modifications or improvements, to this document and the information herein without notice. Customers should obtain and verify the latest relevant information before placing orders for X-REL Semiconductor products. The information contained herein or any use of such information does not grant, explicitly or implicitly, to any party any patent rights, licenses, or any other intellectual property rights, whether with regard to such information itself or anything described by such information.

Unless expressly approved in writing by an authorized representative of X-REL Semiconductor, X-REL Semiconductor products are not designed, authorized or warranted for use in military, aircraft, space, life saving, or life sustaining applications, nor in products or systems where failure or malfunction may result in personal injury, death, or property or environmental damage.

General Sales Terms & Conditions apply.

CONTACT US

For more information on X-REL Semiconductor's products, technical support or ordering:

- ✓ Web: www.x-relsemi.com/products
- ✓ Tel: +33 456 580 580
- ✓ Fax: +33 456 580 599
- ✓ Sales: sales@x-relsemi.com
www.x-relsemi.com/EN/Sales-Representatives
- ✓ Information: info@x-relsemi.com
- ✓ Support: support@x-relsemi.com

X-REL Semiconductor

90, Avenue Léon Blum
38100 Grenoble
France